

**(19) AUSTRALIAN PATENT OFFICE**

(54) Title  
Washing machine with reduced vibration

(51)<sup>6</sup> International Patent Classification(s)  
**D06F** 37/22 (2006.01) 39/12  
**D06F** 37/20 (2006.01) 20060101ALI2005100  
**D06F** 39/12 (2006.01) <sup>8BMEP</sup> **D06F**  
**D06F** 49/06 (2006.01) 49/06  
**F16F** 15/04 (2006.01) 20060101ALI2005122  
**F16F** 15/08 (2006.01) <sup>OBMJP</sup> **F16F**  
D06F 37/22 15/04  
20060101AFI2005122 20060101ALI2005122  
<sup>OBMJP</sup> **D06F** <sup>OBMJP</sup> **F16F**  
37/20 15/08  
20060101ALI2005100 20060101ALI2005122  
<sup>8BMEP</sup> **D06F** <sup>OBMJP</sup>

(21) Application No: 2004201444

(22) Application Date: 2004 .04 .06

(30) Priority Data

(31) Number	(32) Date	(33) Country
P2003-0060269	2003 .08 .29	KR
P2003-0060270	2003 .08 .29	KR
P2003-0024734	2003 .04 .18	KR

(43) Publication Date : 2004 .11 .11

(43) Publication Journal Date : 2004 .11 .11

(71) Applicant(s)  
LG Electronics Inc.

(72) Inventor(s)  
Kim, Young Soo, Park, Jong A, Choi, Seung Bong, Kim, Myong Deok, Ahn, Byung Hwan, Kwon, Ho Chul, Kim, Kwang Soo, Kim, Jae Kyum, Lee, Deug Hee

(74) Agent/Attorney  
Freehills Patent & Trade Mark Attorneys, GPO Box 128, Melbourne, VIC, 3000

(56) Related Art  
EP 1493357  
DE 4413069  
JP 05-253386  
GB 2182353

ABSTRACT

Washing machine including a cabinet forming an outside shape of the washing machine, legs fitted to a bottom of the cabinet for supporting the cabinet, and leg pads joined to an underside of the legs respectively for attenuating vibration taken place when the washing machine is operated, wherein the leg pad is formed of block copolymer of hard blocks and soft blocks, thereby attenuating vibration.

FIG. 8

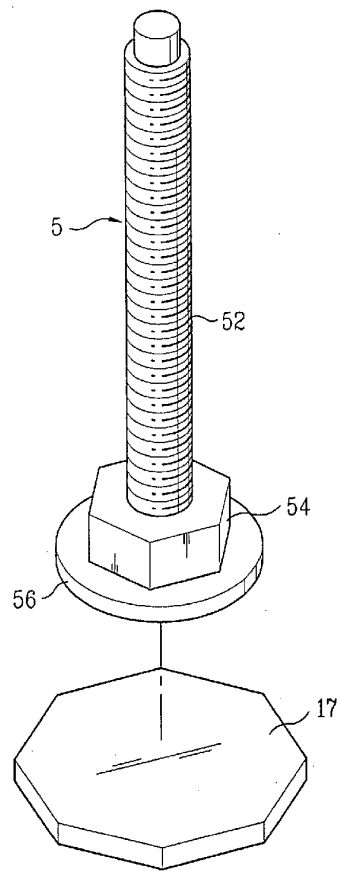

AUSTRALIA

---

*Patents Act 1990*

---

## COMPLETE SPECIFICATION STANDARD PATENT

Invention Title: **Washing machine with reduced vibration**

**The following statement is a full description of this invention, including the best method of performing it known to us:**

This application claims the benefit of the Korean Application Nos. P2003-0024734 filed on April 18, 2003, P2003-0060269 filed on August 29, 2003, and P2003-0060270 filed on August 29, 2003, which are hereby incorporated by reference.

#### BACKGROUND OF THE INVENTION

##### Field of the Invention

The present invention relates to washing machines, and more particularly, to a washing machine which can attenuates vibration during operation of the washing machine effectively.

##### Background of the Related Art

The washing machines, for removing contaminants from laundry by applying energy such as impact, have pulsator washing machines, drum washing machines, and agitator washing machine depending on methods for applying energy to the laundry. The drum washing machine rotates a drum to drop the laundry and give impact to the laundry mostly, to which detergent is added to make washing done. The pulsator, or the agitator washing machine gives impact to the laundry by means of rotating pulsator or agitator connected to a washing shaft vertically mounted in a washing tub, to which detergent is added to make washing done.

That is, the washing machines wash laundry by giving impact to the laundry mostly with mechanical means, for which the washing tub or drum, or the like where the laundry is placed is rotated, that causes in general vibration. According to this, the washing machines are provided with different vibration attenuation means.

Before starting description of a related art vibration attenuating method, as an example of a related art washing machine, the drum washing machine will be described with reference to FIGS. 1 and 2.

A cabinet 3, a body of the washing machine, is provided with a front portion 34, side portions 32, an upper cover 38, and a lower base 36. The front portion 34 of the cabinet has a door 4 mounted to be opened/closed, and the base 36 has legs 5 for supporting the washing machine on a floor the washing machine is installed thereon.

The cabinet 3 has a tub 7 for holding washing water, having a drum 9 rotatably mounted therein for placing laundry therein. The drum 9 has a motor 11 connected thereto for generating a driving force to rotate the drum 9.

In the meantime, upon putting the washing machine into operation, the drum 9 rotates at a high speed, according to which vibration is taken place. Particularly, since the drum 9 rotates at a high speed in a spinning cycle, the vibration is heavy. According to this, different kinds of means are provided to the washing machine for reducing generation of vibration or attenuation of generated vibration.

For an example, for preventing and reducing transmission of the vibration from the drum 9 to the cabinet 3, and the like, there are springs 13 between the tub 7 and the upper cover 38, and dampers 15 between the tub 7 and the base 36. Moreover, material or thickness of the side portions 32 and/or base 36 of the cabinet 3 are adjusted, or beads 32a are formed at the side portions 32 of the cabinet 3. As illustrated in FIG. 3 in detail, a leg pad 17 of a material that can attenuate vibration is fitted to the leg 5.

However, the related art vibration attenuating method and a washing machine thereof has the following problems.

First, correlations between the different kinds of vibration attenuating means have not been clear, to cause a limit in reducing the vibration in an overall point of view, effectively.

Second, effective attenuation of the vibration over all ranges of rotating speed

2004201444  
21 Mar 20072004201444  
21 Mar 2007

of drum or the motor of the washing machine has been difficult. For an example, if a damping forces of the dampers are designed higher for attenuation of transient vibration mostly caused by non-uniform distribution of the laundry when proceeding into a spinning cycle, the vibration becomes heavier in a rated spinning speed to the contrary, and opposite to this, if the damping forces are designed lower, the transient vibration takes place while the vibration at the rated spinning speed is reduced. Moreover, also in the case of the leg pad, since a range of the rotation speed of the washing machine effective for attenuating the vibration is fixed substantially depending on a material of the leg pad, it is difficult to attenuate vibration effectively over all ranges of rotation speed of the washing machine.

#### SUMMARY OF THE INVENTION

Accordingly, the present invention is directed to a washing machine that substantially obviates one or more of the problems due to limitations and disadvantages of the related art.

It would be desirable for the present invention to provide a method for effective attenuation of vibration of a washing machine, and a washing machine thereof.

It would also be desirable for the present invention to provide a method for effective attenuation of vibration of a washing machine, and a washing machine thereof, in which vibration attenuation is effective over all ranges of rotation speed of the washing machine.

Additional features and advantages of the invention will be set forth in the description which follows, and in part will be apparent to those having ordinary skill in the art upon examination of the following or may be learned from practice of the invention. The advantages of the invention will be realised and attained by the structure particularly pointed out in the written description and claims hereof as well as the appended drawings.

To achieve these advantages and in accordance with the purpose of the present invention, as embodied and broadly described herein, the washing machine includes a cabinet forming an outside shape of the washing machine, legs fitted to a bottom of the cabinet for supporting the cabinet, and leg pads joined to an underside of the legs

2004201444 21 Mar 2007

respectively for attenuating vibration taken place when the washing machine is operated, wherein the leg pad is formed of block copolymer of hard blocks and soft blocks. The leg pad of the washing machine installed on a slippery floor has Shore hardness of approx. 80.

5 The leg pad includes a first member in contact with a floor having the washing machine installed thereon, and a second member in contact with the first member, wherein, preferably, at least one of the first member and the second member is the block copolymer of hard blocks and soft blocks.

10 In the meantime, preferably, the hard block is a material which meets required mechanical properties, and the soft block is a material which meets vibration attenuation characteristic. Preferably, the soft block has a glass transition temperature of room temperature, and more preferably,  $-30^{\circ}\text{C} \sim 30^{\circ}\text{C}$ .

In the meantime, preferably, the leg pad of the washing machine installed on a non-slippery floor has Shore hardness of approx. 30.

15 In the meantime, preferably, the hard block is polystyrene, and the soft block is polyisoprene, and more preferably, the soft block is vinyl-polyisoprene. The block copolymer is preferably blended with at least one selected from olefin based thermoplastic resin, ethylene- $\alpha$  olefin copolymer, ethylene-vinylacetate copolymer, ethylene-ethylacrylate copolymer, styrene-butadiene-styrene copolymer, and styrene-isoprene-20 styrene copolymer.

In another aspect of the present invention, there is provided a washing machine including a cabinet forming an outside shape of the washing machine, a tub in the cabinet for

holding washing water, a drum rotatably mounted in the tub, dampers fitted between a base of the cabinet and the tub for reducing transmission of vibration from the drum, wherein the damper is coupled to the cabinet, with a first damping member in contact with the damper, and a second damping member in contact with the first damping member placed inbetween, and at least one of the first damping member, and the second damping member is block copolymer of hard blocks and soft blocks.

Also, the hard block is a material which meets required mechanical properties, and the soft block is a material which meets vibration attenuation characteristic.

Thus, the present invention can attenuate vibration generated at the washing machine, effectively.

It is to be understood that both the foregoing description and the following detailed description of the present invention are exemplary and explanatory and are intended to provide further explanation of the invention claimed.

#### BRIEF DESCRIPTION OF THE DRAWINGS

The accompanying drawings, which are included to provide a further understanding of the invention and are incorporated in and constitute a part of this application, illustrate embodiment(s) of the invention and together with the description serve to explain the principle of the invention.

In the drawings;

FIG. 1 illustrates a perspective view of a related art drum washing machine;

FIG. 2 illustrates a longitudinal section of FIG. 1;

FIG. 3 illustrates a side view of the leg in FIG. 1;

FIGS. 4 and 5 illustrate graphs each showing a principle and effect of a washing machine with reduced vibration in accordance with a preferred embodiment of the present

invention;

FIG. 6 illustrates a structure of a leg pad applicable to a washing machine with reduced vibration in accordance with a preferred embodiment of the present invention, schematically;

FIG. 7 illustrates a comparative graph of damping forces of the leg pads of the present invention and the related art;

FIG. 8 illustrates a disassembled perspective view of a leg and a leg pad in accordance with a preferred embodiment of the present invention;

FIG. 9 illustrates a side view of FIG. 8;

FIG. 10 illustrates a section of a leg and a leg pad in accordance with another preferred embodiment of the present invention;

FIG. 11 illustrates a section of a leg and a leg pad in accordance with still another preferred embodiment of the present invention;

FIG. 12 illustrates a section of a leg pad in accordance with another preferred embodiment of the present invention;

FIG. 13 illustrates a section of a variation of FIG. 12;

FIGS. 14A and 14B illustrate a section and a plan view of a leg pad in accordance with another preferred embodiment of the present invention, respectively;

FIGS. 15A and 15B illustrate a section and a plan view of a variation of FIGS. 14A or 14B;

FIGS. 16 and 17 illustrate sections each showing a leg pad in accordance with another preferred embodiment of the present invention; and

FIGS. 18 ~ 21 illustrate sections each showing a detail of a damper fastening portion in a washing machine with reduced vibration of the present invention.

#### DETAILED DESCRIPTION OF THE PREFERRED EMBODIMENT

Reference will now be made in detail to the preferred embodiments of the present invention, examples of which are illustrated in the accompanying drawings.

A principle of a washing machine with a reduced vibration will be described, with reference to FIGS. 4 and 5.

Of various methods for attenuating vibration, the inventor made study for finding out a most effective method for attenuating vibration. As a result, of various parameters, such as damper, material, thickness, and shape of the cabinet, and material of the leg pad, it finds out that optimization of the leg pad is the most effective for reduction of the vibration. Test results verifying that proper design of the leg pad is the most effective for reduction of the vibration are illustrated in FIGS. 4 and 5.

FIGS. 4 and 5 illustrate graphs each showing principle and effect of a washing machine with reduced vibration in accordance with a preferred embodiment of the present invention. That is, vibrations of different washing machines (hereafter called as "samples"), in which various parameters generally known to be effective for vibration are varied, are measured in spinning processes in which vibration can cause the most serious problem, respectively. In the vibration measurement, a 400g of eccentricity is provided, and the vibration is measured at a right side upper corner 'A' and at a right side central portion 'B' of the cabinet with a vibration measuring apparatus (EQP/2).

FIG. 4 illustrates a test result at a right side portion of the cabinet, and FIG. 5 illustrates a test result at a left side portion of the cabinet. In FIGS. 4 and 5, A(Max) denotes a greatest vibration measured at the upper corner, and A(Normal) denotes a normal vibration measured at the upper corner. Alikely, B(Max) denotes a greatest vibration measured at the central portion, and B(Normal) denotes a normal vibration measured at the central portion.

It will be described in detail. Sample 1 denotes a drum washing machine in which a 0.15mm bead depth is added to a general bead depth formed at the side of the cabinet, and the leg pad is formed of butyl rubber the same with the related art. Sample 1a denotes the same washing machine with sample 1, except that material of the leg pad is different. Sample 2 denotes a drum washing machine in which no bead depth is changed, or material of the leg pad is also the butyl rubber of the related art. Sample 2a denotes a washing machine the same with sample 2, except that the material of the leg pad is different.

As the material for the leg pad used in sample 1a and sample 2a, a material that shows the best result is used among many materials the inventor studied and tested. (the leg pad will be described in detail, later).

FIGS. 4 and 5 are analyzed as follows.

Upon reviewing test results of sample 1 and sample 2 of which leg pads are the same, and bead depths only are different, it can be noted that deeper bead depth is effective for attenuation of vibration for some extent. However, it can be known that correlation between the bead depth and the vibration attenuation is not clear.

However, upon reviewing test results of sample 1 and sample 1a, or sample 2 and sample 2a, of which bead depths are the same, and the leg pads are different, it can be noted that a proper leg pad is very effective for attenuating vibration.

Moreover, upon reviewing test results of sample 1a and sample 2a, it can be known that optimization of the material of the leg pad is more effective for vibration attenuation than the bead depth.

Therefore, for effective vibration attenuation, it is preferable that the leg pad is designed the most properly.

As described above, it is preferable that the leg pad is designed the most

properly for effective vibration attenuation. Therefore, it is preferable that, first of all, the most suitable leg pad, particularly, the most suitable material of the leg pad is used for attenuation of the vibration, and the other vibration attenuation parameters are taken into consideration. According to this, the inventor studied on the leg pad suitable for vibration attenuation further, to obtain the following results.

First of all, it is required that the leg pad has an excellent vibration attenuating characteristic. However, for use as the leg pad actually, it is required to meet, not only the vibration attenuating characteristic, but also other various conditions. For an example, conditions, such as mechanical properties, such as hardness, anti-slip property for preventing the washing machine from slipping from an installed place, formability representing easiness of fabrication, and the like are required to be satisfied. Because, even if the vibration attenuation characteristic is satisfied, if the material fails to have a proper hardness, resonance is occurred at a certain range of rotation speed of the washing machine, to cause walking of the washing machine. If friction with the floor is not adequate, it is liable that the washing machine slips on the floor.

At the end, even though it is required that the leg pad meets above different conditions in addition to the vibration attenuating characteristic, selection of an optimal leg pad that meets above conditions substantially has been difficult in the related art. Accordingly, up to now, as the leg pad, metal, plastic, isobutylene-isoprene rubber, or the like is used, each of the material has advantages, and disadvantages. Even though metal or plastic, with a comparatively high hardness, has a resonance range outside of rotation speed of the washing machine, it is liable that the leg pad of metal or plastic causes walking of washing machine in almost all ranges of the rotation speed, regardless of the rotation range. Moreover, the leg pad of metal or plastic is liable to cause slipping of the washing machine because the metal or

plastic has low friction with the floor on which the washing machine is installed. In a case of the butyl rubber, since the butyl rubber has a resonance range in a low rotation speed range of the washing machine, it is required that the washing machine is controlled to pass the resonance range quickly, and the leg pad of the butyl rubber is liable to cause walking of the washing machine in the low rotation speed range, even though the walking is comparatively rare in a high rotation speed range.

As a result of study on the material of the leg pad for solving above problems, the inventor finds out that use of a block copolymer of hard blocks and soft blocks is very effective as the material of the leg pad. That is, as illustrated in FIG. 6, the inventor finds out that the leg pad is preferably formed of a copolymer in which the hard blocks HS and the soft blocks SS make a net form. Because the use of the leg pad of the copolymer of the hard blocks HS and the soft blocks SS enables to select a material that meets required mechanical properties, such as hardness, as the hard blocks, and a material that meets required vibration attenuation characteristic as the soft blocks. According to this, the leg pad can be designed comparatively easily, that meets the vibration attenuation characteristics while other conditions are met.

In view of vibration attenuation, it is preferable that a material that has a glass transition is used as the block copolymer, particularly, the soft block, and more preferably, a material of which glass transition temperature is close to a temperature of use of the washing machine. Because, though thermal movement of chain form of polymers in the net becomes violent at a temperature higher than the glass transition temperature, to exhibit a rubbery state, the thermal movement is suppressed at a temperature below the glass transition temperature, to become a glassy state due to reduction of its own volume, and have a poor vibration attenuation effect.

Since amorphous polymers, such as rubber, exhibit the glass transition, it is preferable that rubber is selected as the leg pad. The butyl rubber used presently also exhibits the glass transition. However, as described before, though the leg pad is required to meet, not only the vibration attenuation characteristic, but also other properties, different from the block copolymer of the hard blocks and the soft blocks of the present invention, the butyl rubber, a copolymer prepared by copolymerizing a small amount of isoprene with isobutylene, can not meet other properties besides the vibration attenuation characteristic. In view of the vibration attenuation characteristic, it is difficult to obtain the desired adequate vibration attenuation effect because the butyl rubber has a glass transition temperature in a range of  $-40^{\circ}\text{C} \sim -60^{\circ}\text{C}$ , which is substantially low than the temperature of use of the washing machine. As shown in FIG. 7, in a case of the butyl rubber, though the butyl rubber has a uniform damping force in a temperature range of use of the washing machine substantially, in an actual temperature range of use of the washing machine, the damping force of the leg pad of the butyl rubber is poorer than the leg pad of the block copolymer of the present invention.

As described, preferably, the leg pad of the present invention is formed of a block copolymer of hard blocks and soft blocks, wherein the hard blocks are selected in mechanical point of view, and the soft blocks are selected in view of vibration attenuation.

Accordingly, it is preferable that a material is selected as the soft block, of which glass transition temperature is in the vicinity of the temperature of use of the washing machine. Of course, it is preferable that a material is selected as the hard blocks in view of requirements of mechanical properties, such as hardness. For an example, in a case of washing machine installed on a slippery floor of cement or tile, it is favorable that a hardness of the leg pad is high. In general, it is preferable that Shore hardness is approx. 80. Opposite to this, in a case of floor of wood, it is preferable that the hardness is low, in general, approx.

30 in Shore A hardness.

As a result of test on various materials, the inventor finds out that the hard block is polystyrene, and the soft block is polyisoprene, particularly, vinyl-polyisoprene.

In fabrication of the leg pad, though the block copolymer may be used solely, at least one selected from olefin based thermo plastic resin, ethylene- $\alpha$  olefin copolymer, ethylene-vinylacetate copolymer, ethylene-ethylacrylate copolymer, styrene-butadiene-styrene copolymer, and styrene-isoprene-styrene copolymer may be blended with the block copolymer. Moreover, additives, such as cross-linker, filler, and softner, may be introduced into a base material of the block copolymer, that is known to a person skilled in the field of art, of which detailed description will be omitted.

As described, the leg pad of the block copolymer of hard block and soft block enables to fabricate a leg pad that satisfies the vibration attenuation characteristic and other required properties very much.

In order to verify this, a test is carried out on a material that substantially satisfies above conditions among commercially available materials. The material used in the test is Kuraray Hybrar. The Hybrar, a block copolymer of polystyrene and polyisoprene, has a glass transition temperature in the vicinity of room temperature of approx.  $-19^{\circ}\text{C} \sim -8^{\circ}\text{C}$ . As shown in FIG. 7, it is verified that the leg pad of the Hybrar has very good damping force in the vicinity of room temperature. In FIG. 4 or 5, the material of the leg pad in the sample 1a and the sample 2a is Hybrar. Of course, the material suitable for the leg pad is not limited to Hybrar, and any material that satisfies above conditions can be used.

In the meantime, as described, it is preferable that the leg pad has, not only an excellent vibration attenuation characteristic, but also excellent formability and workability taking production cost of the washing machine into consideration. Hybrar has a better anti-

slip characteristic than butyl rubber, and particularly, has a good friction even in a watery environment compared to other rubbers. Moreover, since the Hybrar can be used as a thermoplastic resin that can be injection molded or extrusion molded, or thermosetting resin that can be pressed, the Hybrar also has an advantage of good formability. However, if it is intended to use the Hybrar as the thermosetting resin, a separate cross-linker is required.

In the meantime, referring to FIG. 8, the leg is joined to the leg pad by a predetermined method. Examples of preferable joining of the leg and the leg pad will be described with reference to FIGS. 8 ~ 11.

First, the leg will be described. In general, the leg 5 includes a cylindrical body 52, and a head 54 at a bottom end of the body 52. It is preferable that the body 52 has a thread formed therein for easy adjustment of a height. The head 54 is used for easy turning of the body 52 with a thread, to make adjustment of the height easy.

In the meantime, the leg pad 17 is fitted to a bottom end of the leg 5. Though the leg pad 17 may be fitted to the head 54 of the leg 5 directly, it is preferable that an enlarged portion 56 may be further formed in a lower portion of the head 54 for securing a fitting area, and easy fitting.

The leg 5 and the leg pad 17 may be joined by insert molding, bonding, or other methods. For an example, as shown in FIG. 9, the leg 5 and the leg pad 17 may be joined with an adhesive. Or, as shown in FIG. 10, the leg 5 and the leg pad 17 may be joined by insert molding. Or, as shown in FIG. 11, a recess 17a having a portion of a lower portion of the leg pad 17 cut away therefrom in a circumferential direction may be formed, and the leg 5 and the leg pad 17 may be joined with an elastic hook 19 that surrounds the enlarged portion 56 of the leg and the recess 17a in the leg pad 17.

In the meantime, though a leg pad formed of one material, i.e., the block

copolymer is described in above embodiment, as a result of study of the inventor, it is found out that it is possible to form the leg pad of more than two materials. That is, it is preferable that the leg pad is formed of a first member in contact with a floor the washing machine is installed thereon, and a second member in contact with the first member, and one of the first, and second members is formed of block copolymer, and the other one is formed of other material, such as butyl rubber. Because above material of the leg pad, i.e., the block copolymer of the hard blocks, and the soft blocks may cause plastic deformation after a certain time period, to have a poor vibration attenuation effect. Particularly, the vibration attenuation effect can become poor in a low temperature range.

Another embodiment of the leg pad of the present invention will be described, with reference to FIGS. 12 to 17.

Referring to FIG. 12, the leg pad 17 includes a first member 17a in contact with a floor having the washing machine installed thereon, and a second member 17b fitted to the first member 17a, wherein it is preferable that one of the first member 17a and the second member 17b is formed of butyl rubber, and the other one is formed of block copolymer. For the sake of description, a right side upward hatching (for an example, a reference symbol 17b in FIG. 12) denotes that the material is block copolymer, and the other mark on the section (for an example, a reference symbol 17a in FIG. 12) denotes that the material is butyl rubber.

Referring to FIG. 12, though the first member 17a may be formed of butyl rubber, and the second member 17b may be formed of block copolymer, as shown in FIG. 13, it is more preferable that the first member 17a is formed of block copolymer, and the second member 17b is formed of butyl rubber. Because the block copolymer has better contact with the floor, it is favorable that the first member 17a is formed of the block copolymer.

In the meantime, referring to FIGS. 14A and 14B, the first member 17a may

have a projection 170 having the second member 17b passed through. Or, as shown in FIGS. 15A and 15B, the first member 17a may have a plurality of projections 170 having the second member 17b passed through.

Or, referring to FIGS. 16 and 17, a third member 17c of a material the same with the first member 17a may be fitted to top of the second member 17b.

In the meantime, the first member 17a, the second member 17b, and the third member 17c may be joined by bonding, or double injection molding, and the leg pad 17 and the leg may be joined by bonding, insert molding, or mechanical joining, as described before.

In the meantime, in the study of the inventor, it finds out that the principle of the present invention is applicable not only to the leg, but also to other components, used in the washing machine and the like as a vibration attenuator. Particularly, it is preferable that the principle of the present invention is applied to the damper fitted between the base of the cabinet and the tub for preventing vibration of the washing machine and the like from transmitting to the cabinet.

The application of the principle of the present invention to the damper of the drum washing machine will be described with reference to FIG. 18.

One end of the damper 15 is fixed to the base 36 with a damping member 100 placed in between. In this instance, though the damping member 100 may be formed of one material solely, i.e., the block copolymer, as a result of study of the inventor, it is found out that it is possible to form the damping member 100 of the present invention of more than two materials, for an example, one is formed of block copolymer, and the other one is formed of other material, such as butyl rubber. Because the block copolymer of the hard blocks, and the soft blocks may cause plastic deformation after a certain time period, to have a poor vibration attenuation effect. Particularly, the vibration attenuation effect can become poor in a low

temperature range.

It will be described in more detail. For the sake of description, a right side upward hatching (for an example, a reference symbol 120 in FIGS. 18 ~ 21) denotes that the material is block copolymer, and the other mark on the section (for an example, a reference symbol 110 in FIGS. 18 ~ 21) denotes that the material is butyl rubber.

Referring to FIG. 18, the damper 15 is fixed to the base 36 with a first damping member 110 in contact with the damper 15, and a second damping member 120 in contact with the first damping member 110 placed inbetween, wherein one of the first damping member 110 and the second damping member 120 is a block copolymer of hard blocks and soft blocks.

In more detail, the damper 15 has a hollow coupling portion 15a at one end (a portion near to the base of cabinet). The coupling portion 15a has a cylindrical first damping member 110 fitted therein, and a cylindrical second damping member 120 is fitted in the hollow of the first damping member 110. There is a bracket 16 fixed to the base 36, having one side opened to a damper direction.

That is, the coupling portion 15a of the damper 15, the first damping member 110, and the second damping member 120 are positioned in the opening of the bracket 16, and, under this state, a bolt 16a is passed through the bracket 16, and the second damping member 120, to have the damper 15 fitted between the tub and the cabinet.

In the meantime, referring to FIG. 18, it is also possible that the first damping member 110 is formed of butyl rubber, and the second damping member 120 is formed of block copolymer. However, as shown in FIG. 19, it is preferable that the first damping member 110 is formed of the block copolymer, and the second damping member 120 is formed of butyl rubber, because it is favorable in view of vibration attenuation that the first

damping member 110 that comes into contact with the damper 15 at first is formed of the block copolymer.

Moreover, referring to FIGS. 20 and 21, it may also be possible that a third damping member 130 formed of a material the same with the material of the first damping member 110 is fitted on an inside of the second damping member 120. Of course, it is also possible that the third damping member 130 formed of a material the same with the material of the second damping member 120 is fitted on an outside of the first damping member 110.

In the meantime, besides that the first damping member 110, the second damping member 120, and the third damping member 130 may be joined by bonding or double injection molding, the components may be joined by other methods, of which detail will be omitted.

Though a drum washing machine is illustrated and described in above embodiments, the present invention is not limited to this. That is, the present invention is applicable to the pulsator washing machine, and the agitator washing machine, too. Moreover, the present invention is applicable, not only to a leg joined to the cabinet, a body, but also to other components that are used for attenuation of vibration in the washing machine.

It will be apparent to those skilled in the art that various modifications and variations can be made in the present invention without departing from the spirit or scope of the invention. Thus, it is intended that the present invention cover the modifications and variations of this invention provided they come within the scope of the appended claims and their equivalents.

As has been described, the method for attenuating vibration of a washing machine, and a washing machine thereof has the following advantages.

First, vibration can be attenuated effectively by selecting the leg pads, properly.

That is, vibration of the washing machine can be reduced effectively while changes in design, and a cabinet material, thickness, and bead depth that causes a production cost increases are minimized. That is, by proper selection of the damping member of the damper, and the leg pad of which design and effect verification are comparatively easy, the vibration can be attenuated very effectively.

Second, the present invention permits to select a leg pad, which meets not only the vibration attenuation characteristic, but also other necessary properties, such as hardness, and anti-slip characteristic, at the same time, thereby permitting to make a washing machine design effective in vibration attenuation over all ranges of rotation speed of the washing machine.

2004201444 21 Mar 2007

THE CLAIMS DEFINING THE INVENTION ARE AS FOLLOWS:

1. A washing machine comprising:
  - a cabinet forming an outside shape of the washing machine;
  - legs fitted to a bottom of the cabinet for supporting the cabinet; and
  - 5 leg pads joined to an underside of the legs respectively for attenuating vibration taken place when the washing machine is operated,
  - wherein the leg pad is formed of block copolymer of hard blocks and soft blocks, and wherein the leg pad of the washing machine installed on a slippery floor has Shore hardness of approx. 80.
- 10 2. The washing machine as claimed in claim 1, wherein the leg pad includes:
  - a first member in contact with a floor having the washing machine installed thereon, and
  - a second member in contact with the first member,
  - wherein at least one of the first member and the second member is the block
  - 15 copolymer of hard blocks and soft blocks.
3. The washing machine as claimed in claim 2, wherein the hard block is a material which meets required mechanical properties, and the soft block is a material which meets vibration attenuation characteristic.
4. The washing machine as claimed in claim 2, wherein the soft block has a glass
- 20 transition temperature of room temperature.
5. The washing machine as claimed in claim 4, wherein the glass transition temperature is  $-30^{\circ}\text{C} \sim 30^{\circ}\text{C}$ .

21 Mar 2007

2004201444

6. The washing machine as claimed in claim 3, wherein the leg pad of the washing machine installed on a non-slippery floor has Shore hardness of approx. 30.
7. The washing machine as claimed in claim 3, wherein the hard block is polystyrene, and the soft block is polyisoprene.
- 5 8. The washing machine as claimed in claim 3, wherein the soft block is vinyl-polyisoprene.
9. The washing machine as claimed in claim 8, wherein the block copolymer is blended with at least one selected from olefin based thermo plastic resin, ethylene- $\alpha$  olefin copolymer, ethylene-vinylacetate copolymer, ethylene-ethylacrylate copolymer, styrene-butadiene-styrene copolymer, and styrene-isoprene-styrene copolymer.
- 10 10. The washing machine as claimed in claim 3, wherein the leg and the leg pad are bonded with an adhesive.
11. The washing machine as claimed in claim 3, wherein the leg and the leg pad are joined by insert moulding.
- 15 12. The washing machine as claimed in claim 3, wherein the leg and the leg pad are joined by elastic hook.
13. The washing machine as claimed in claim 2, wherein the first member has at least one projection passed through the second member.
14. The washing machine as claimed in claim 2, wherein the second member has a  
20 third member in contact therewith, of a material the same with the first member.
15. A washing machine comprising:
- a cabinet forming an outside shape of the washing machine;
  - a tub in the cabinet for holding washing water;

2004201444 21 Mar 2007

a drum rotatably mounted in the tub;

dampers fitted between a base of the cabinet and the tub for reducing transmission of vibration from the drum,

wherein the damper is coupled to the cabinet, with a first damping member in contact with the damper, and a second damping member in contact with the first damping member placed in between, and at least one of the first damping member, and the second damping member is block copolymer of hard blocks and soft blocks, and wherein the damper of the washing machine installed on a slippery floor has a Shore hardness of approx. 80.

- 0 16. The washing machine as claimed in claim 15, wherein the second damping member has a third damping member in contact therewith, of a material the same with the first damping member.
17. The washing machine as claimed in claim 15, wherein the hard block is a material which meets required mechanical properties, and the soft block is a material which meets vibration attenuation characteristic.
18. The washing machine as claimed in claim 17, wherein the soft block has a glass transition temperature of room temperature.
19. The washing machine as claimed in claim 18, wherein the glass transition temperature is  $-30\text{ }^{\circ}\text{C} \sim 30\text{ }^{\circ}\text{C}$ .
- 20 20. The washing machine as claimed in claim 17, wherein the hard block is polystyrene, and the soft block is polyisoprene.
21. The washing machine as claimed in claim 20, wherein the soft block is vinyl-polyisoprene.

2004201444 21 Mar 2007

22. The washing machine as claimed in claim 20, wherein the block copolymer is blended with at least one selected from olefin based thermoplastic resin, ethylene- $\alpha$  olefin copolymer, ethylene-vinylacetate copolymer, ethylene-ethylacrylate copolymer, styrene-butadien-styrene copolymer, and styrene-isoprene-styrene copolymer.
- 5 23. The washing machine substantially as hereinbefore described with reference to Figures 4 to 21.

Dated : 21 March 2007

**Freehills Patent & Trade Mark Attorneys**  
Patent Attorneys for the Applicant/s:

10

LG Electronics Inc.

FIG. 1  
Related Art

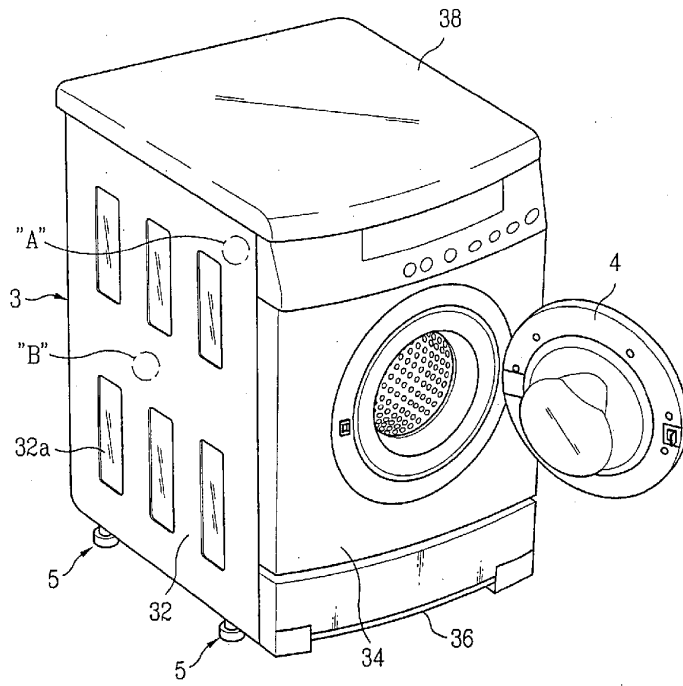

FIG. 2  
Related Art

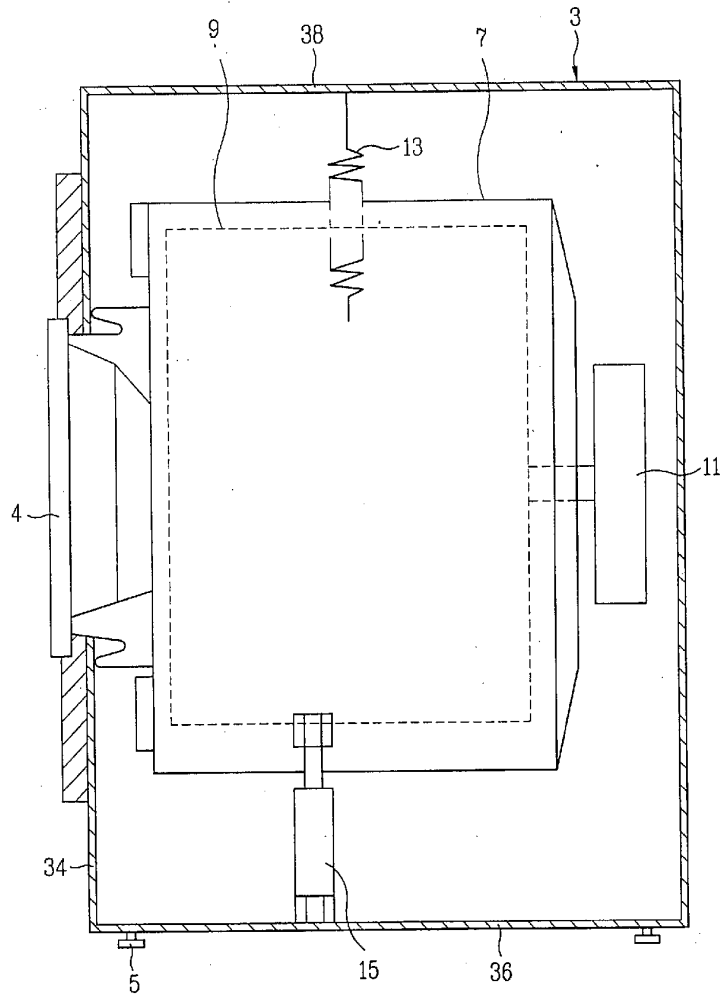

FIG. 3  
Related Art

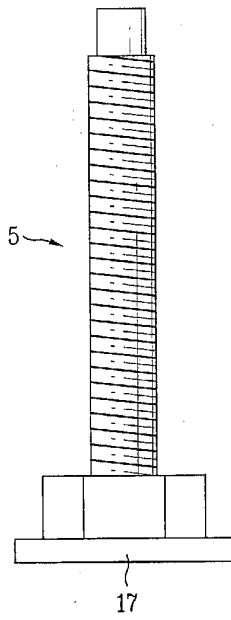

FIG. 4

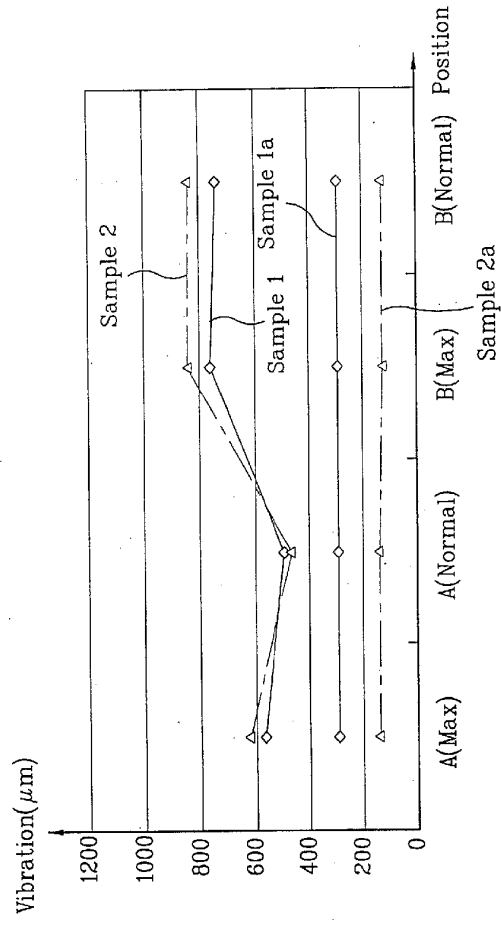

FIG. 5

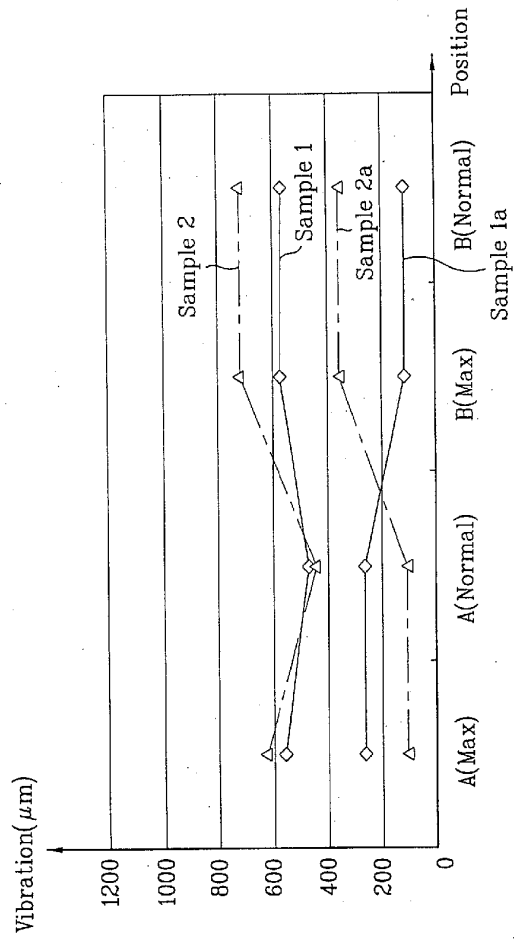

FIG. 6

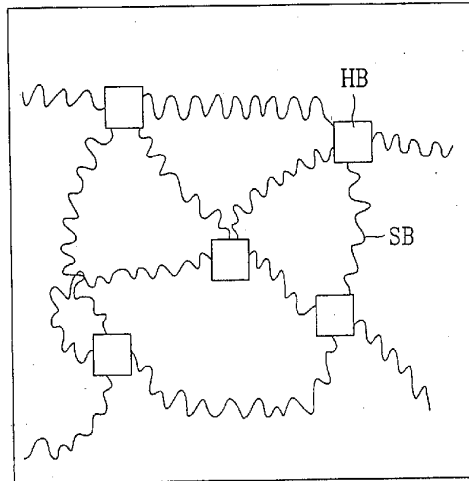

FIG. 7

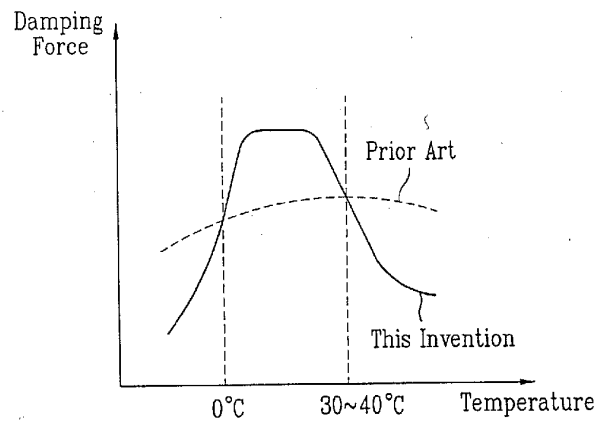

FIG. 8

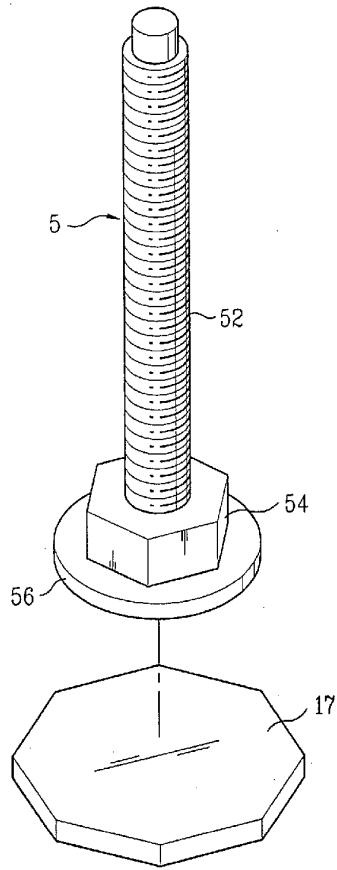

FIG. 9

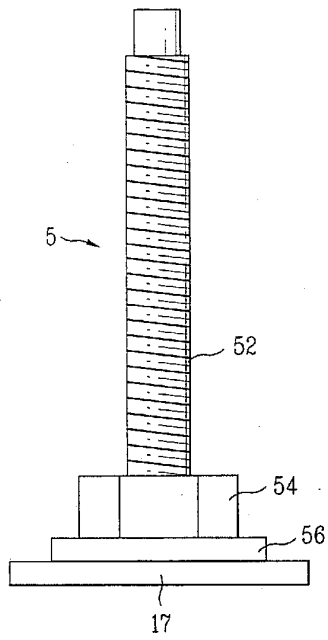

FIG. 10

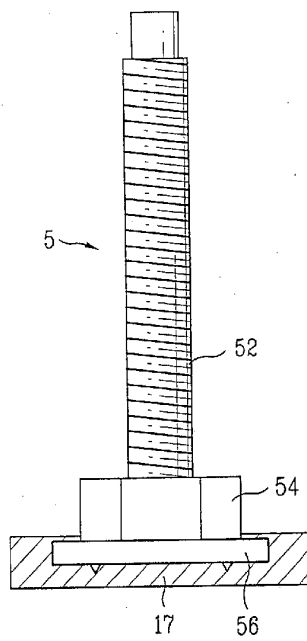

FIG. 11

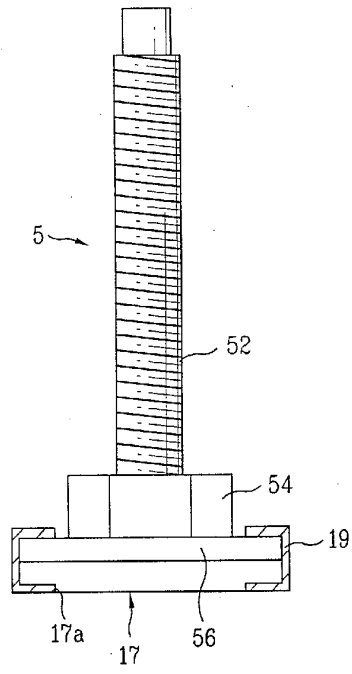

FIG. 12

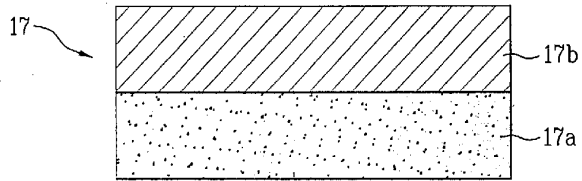

FIG. 13

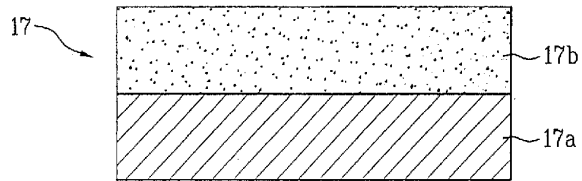

FIG. 14a

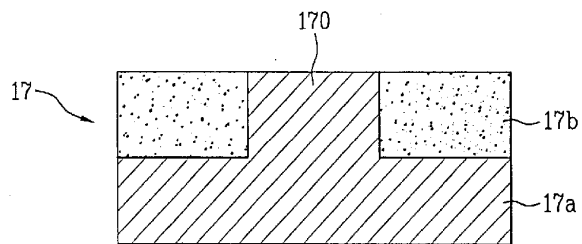

FIG. 14b

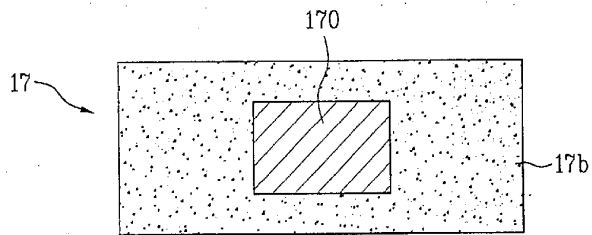

FIG. 15a

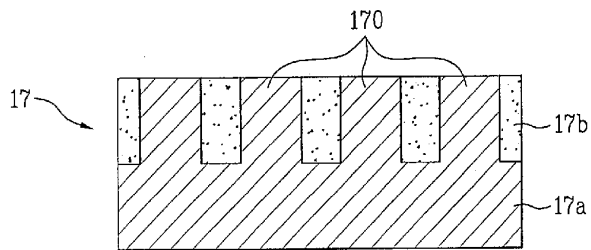

FIG. 15b

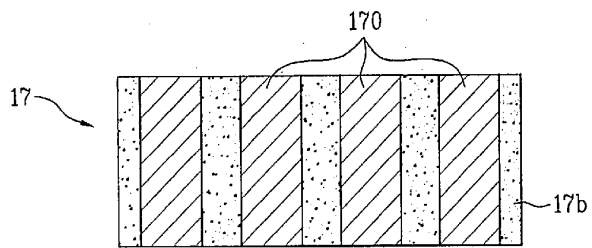

FIG. 16

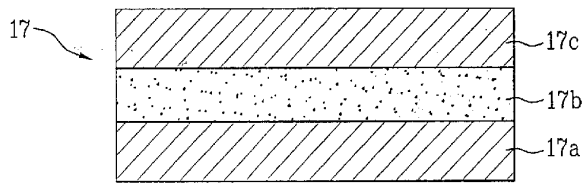

FIG. 17

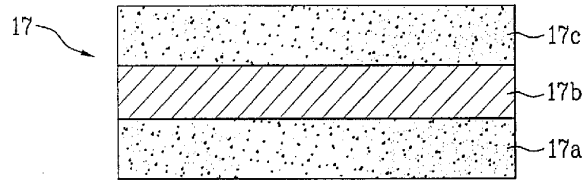

FIG. 18

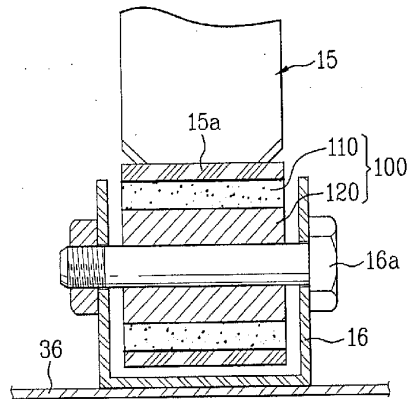

FIG. 19

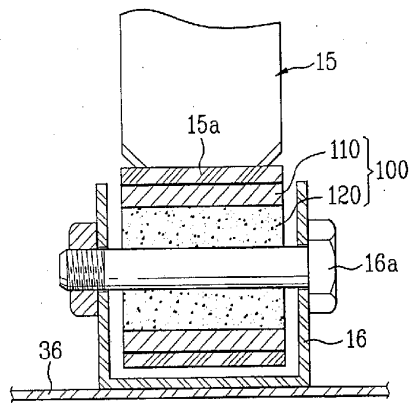

FIG. 20

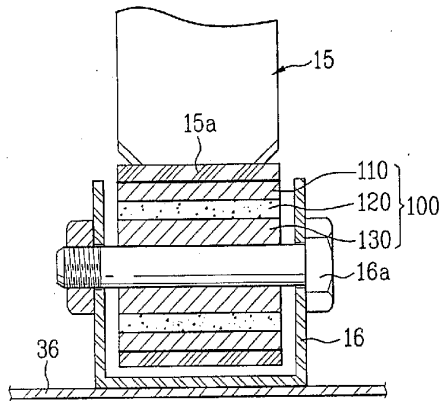

FIG. 21

