

AUSTRALIA
Patents Act 1990

NOTICE OF ENTITLEMENT

I GÖRAN SUNDHOLM

of Ilmari Kiannon kuja 3, FIN-04310 TUUSULA, FINLAND

being the Applicant and Nominated Person, in respect of Application No. 51516/93, entitled Method and Installation for Fighting Fire state the following:

I am the actual inventor of the invention the subject of the Application.

I am the applicant of the application listed in the declaration under Article 8 of the PCT.

Convention priority is claimed from the following basic application(s) referred to in the declaration under Article 8 of PCT:

Basic Applicant	Application Number	Application Date	Country	Country Code
GÖRAN SUNDHOLM	924752	20/10/92	Finland	FI
GÖRAN SUNDHOLM	931405	29/03/93	Finland	FI

The basic application referred to in the declaration under Article 8 of the PCT was the first application made in a convention country in respect of the invention the subject of the Application.

DATED this 13th day of November 1996

GÖRAN SUNDHOLM
By his Patent Attorney

GRIFFITH HACK

67 4 8 9 0

OUR REF: P23305J:RPW:SLC



AU9351516

(12) PATENT ABRIDGMENT (11) Document No. AU-B-51516/93
(19) AUSTRALIAN PATENT OFFICE (10) Acceptance No. 674890

- (54) Title
METHOD AND INSTALLATION FOR FIGHTING FIRE
- International Patent Classification(s)
(51)⁶ A62C 003/16
(51)⁵ A62C 035/62
- (21) Application No. : 51516/93 (22) Application Date : 19.10.93
- (87) PCT Publication Number : WO94/08659
- (30) Priority Data
- | (31) Number | (32) Date | (33) Country |
|-------------|-----------|--------------|
| 924752 | 20.10.92 | FI FINLAND |
| 931405 | 29.03.93 | FI FINLAND |
- (43) Publication Date : 09.05.94
- (44) Publication Date of Accepted Application : 16.01.97
- (71) Applicant(s)
GORAN SUNDHOLM
- (72) Inventor(s)
GORAN SUNDHOLM
- (74) Attorney or Agent
GRIFFITH HACK , GPO Box 4164, SYDNEY NSW 2001
- (56) Prior Art Documents
WO 92/22353
WO 91/00122
US 1263291
- (57) Claim

1. A method for fighting fire, in particular in a room, comprising:

spraying a liquid spray having comparatively large droplets and a good penetration power in order to at least suppress the fire; and

spraying a scattered spray comprising a mixture of liquid and a non-combustible gas in order to extinguish smouldering fire seats, characterized in that

a high pressure of up to 300 bar is used for creating the liquid spray, whereby the droplets are sprayed as a fog-like liquid spray which is produced from nozzles having a combination of mutual distance, spray direction and outlets that, together with said high pressure, produce a suction which keeps the fog-like liquid sprays of the nozzles together as a concentrated fog-like liquid spray, whereafter

the spraying of the fog-like liquid concentrated spray is stopped by lowering the pressure and by adding

(11) AU-B-51516/93
(10) 674890

-2-

the non-combustible gas to the liquid to be sprayed from the nozzles, whereby a scattered spray in the form of a turbulent liquid fog is formed.

6. An installation for fighting fire, in particular a fire in a room, comprising a spray head producing a liquid spray, and a drive unit, having at least one hydraulic accumulator with an outlet connected to the spray head, the accumulator comprising a liquid space and gas space, whereby the liquid is arranged to be driven out through a tube which starts at the bottom portion of the liquid space and extends through the gas space to the outlet, whereby the tube has at least one aperture in its wall, at a predetermined distance from the outlet end of the tube and with a predetermined diameter, so that drive gas flows into the tube through said at least one aperture in the wall, when the liquid level in the hydraulic accumulator has descended to said aperture, in order to thereby intermix with the liquid and thus produce a scattered spray, characterized in that the spray head has nozzles capable of producing fog-like sprays at high operating pressure, whereby the nozzles have a combination of mutual distance, spray direction and outlets, which in combination, together with a high pressure of up to 300 bar, produces a suction which keeps the fog-like liquid sprays of the nozzles together as a concentrated fog-like liquid spray with good penetration power.



IN1

(51) International Patent Classification ⁵ : A62C 3/00, 13/62, 35/00 A62C 35/62	A1	(11) International Publication Number: WO 94/08659 (43) International Publication Date: 28 April 1994 (28.04.94)
--	----	--

(21) International Application Number: PCT/FI93/00429
(22) International Filing Date: 19 October 1993 (19.10.93)

Published
With international search report.

(30) Priority data:
924752 20 October 1992 (20.10.92) FI
931405 29 March 1993 (29.03.93) FI

(71)(72) Applicant and Inventor: SUNDHOLM, Göran [FI/FI];
Ilmari Kiannon kuja 3, FIN-04310 Tuusula (FI).

(74) Agent: VALROS, Frey; Marioff Ky, PB 25, FIN-01511
Vantaa (FI).

(81) Designated States: AT, AU, BB, BG, BR, BY, CA, CH, CZ,
DE, DK, ES, FI, GB, HU, JP, KP, KR, KZ, LK, LU,
MG, MN, MW, NL, NO, NZ, PL, PT, RO, RU, SD, SE,
SK, UA, US, VN, European patent (AT, BE, CH, DE,
DK, ES, FR, GB, GR, IE, IT, LU, MC, NL, PT, SE),
OAPI patent (BF, BJ, CF, CG, CI, CM, GA, GN, ML,
MR, NE, SN, TD, TG).

674890

(54) Title: METHOD AND INSTALLATION FOR FIGHTING FIRE

(57) Abstract

The object of the invention is to provide a new method and a new installation for fighting fire, including difficult smouldering fires, such as cable fires e.g. in the upper region of a room where the walls meet the ceiling. The fire is initially, in a first step, fought by means of at least one fog-like liquid spray having comparatively large droplets and a good penetration power, in order to at least suppress the fire, and thereafter, in a second step, the initially utilized fog-like liquid spray is scattered, by mixing a pressurized non-combustible gas into the liquid, to form a turbulent liquid fog for filling the fire room at least essentially evenly and for extinguishing smouldering fire seats.

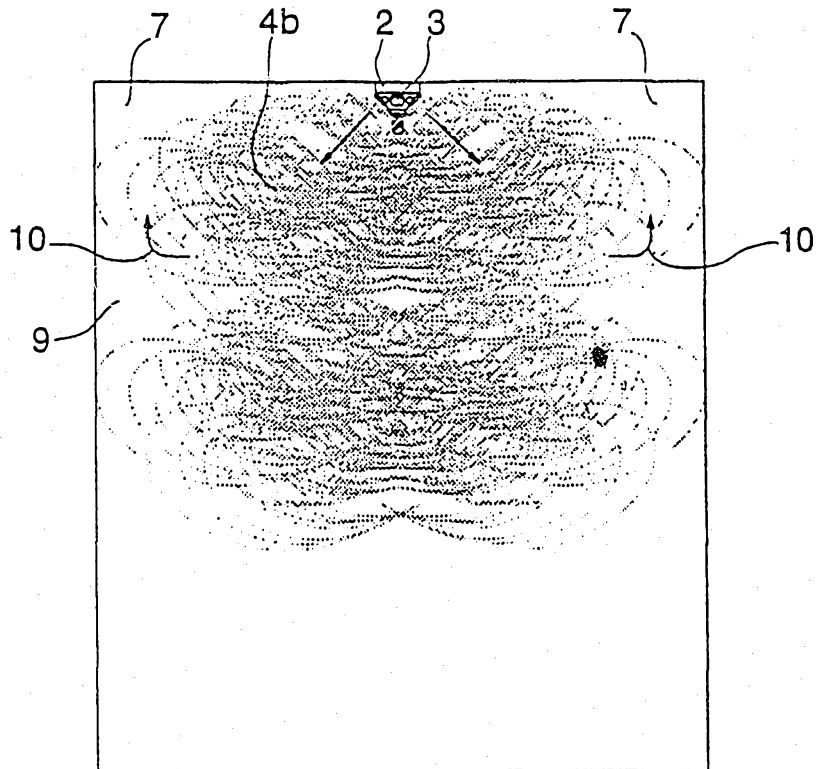

Method and installation for fighting fire

The present invention relates to a method and an installation for fighting fire.

5 A problem with fighting a fire in a room by means of a preferably automatically releasable installation for fighting fire is that the main fire seat, and secondary fire seats and smaller fires in general as well, may not be totally extinguished but can remain smouldering.

10 Difficult smouldering fires are in particular fires in the upper region of a room where the walls meet the ceiling, e.g. cable fires.

It would be advantageous it at least preferred embodiments of the invention provided a new method and a new installation for fighting fire, including difficult
15 smouldering fires.

The present invention in a first aspect provides a method for fighting fire, in particular in a room, comprising:

20 spraying a liquid spray having comparatively large droplets and a good penetration power in order to at least suppress the fire; and

30 spraying a scattered spray comprising a mixture of liquid and a non-combustible gas in order to extinguish smouldering fire seats, characterized in that

25 a high pressure of up to 300 bar is used for creating the liquid spray, whereby the droplets are sprayed as a fog-like liquid spray which is produced from nozzles having a combination of mutual distance, spray direction and outlets that, together with said high pressure, produce a suction which keeps the fog-like liquid sprays of the nozzles together as a concentrated fog-like liquid spray, whereafter

35 the spraying of the fog-like liquid concentrated spray is stopped by lowering the pressure and by adding the non-combustible gas to the liquid to be sprayed from the nozzles, whereby a scattered spray in the form of a turbulent liquid fog is formed.

By a fog-like spray is meant a spray of small



droplets having a diameter typically 30 to 150 microns and preferably set in a strong whirling motion. As earlier mentioned, by a high pressure is here in general meant from about 30 bar up to about 300 bar, as compared to an operating pressure of generally 2 to 10 bar in conventional sprinkler installations which produce a rain-like spray. It shall be noted, however, that the values given above are not absolute;

9
9
9
9
9
9



definite limiting values are difficult to present.

Large fires are extinguished or are at least suppressed to a great extent by the effect of steam generation; the steam prevents oxygen from entering into the fire and the generation of steam binds large amounts of heat. For smaller fires and smouldering fires it is essential that the air sucked into the fire seat shall have a liquid content sufficient for cooling.

Preferably the initially utilized fog-like liquid spray is scattered by intermixing therein such a gas which is lighter than air, preferably nitrogen, so that the intermixed gas, preferably drive gas from at least one hydraulic high pressure accumulator, rises and brings liquid droplets to the ceiling of the room, in order to ensure that fire seats in the upper regions of a room are extinguished by the combined effect of the gas itself and of the liquid droplets following with the gas.

When nitrogen gas accumulates up under the ceiling, together with small droplets which due to the turbulence remain airborne for a comparatively long time, e.g. smouldering cable fires and the like at the ceiling level are effectively smothered.

By successively, or step-wise, increasing the amount of intermixed gas in relation to the liquid, accordingly smaller droplets are obtained, with a prolonged airborne time in spite of a gradually decreasing turbulence.

If there is reason to assume that a somewhat greater concentration in the lower region of the room would be of advantage in the final stage of the extinguishing process, e.g. argon gas can be used as intermixing gas.



In a second aspect the present invention provides an installation for fighting fire, in particular a fire in a room, comprising a spray head producing a liquid spray, and a drive unit, having at least one hydraulic accumulator with an outlet connected to the spray head, the accumulator comprising a liquid space and gas space, whereby the liquid is arranged to be driven out through a tube which starts at the bottom portion of the liquid space and extends through the gas space to the outlet, whereby the tube has at least one aperture in its wall, at a predetermined distance from the outlet end of the tube and with a predetermined diameter, so that drive gas flows into the tube through said at least one aperture in the wall, when the liquid level in the hydraulic accumulator has descended to said aperture, in order to thereby intermix with the liquid and thus produce a scattered spray, characterized in that the spray head has nozzles capable of producing fog-like sprays at high operating pressure, whereby the nozzles have a combination of mutual distance, spray direction and outlets, which in combination, together with a high pressure of up to 300 bar, produce a suction which keeps the fog-like liquid sprays of the nozzles together as a concentrated fog-like liquid spray with good penetration power.

Preferably said tube has a plurality of apertures in its wall, at different levels, so that as the gas pressure of the hydraulic accumulator decreases, the amount of drive gas mixed into the extinguishing liquid increases.

For relatively small spaces it may be sufficient to have a drive unit comprising one single hydraulic accumulator. In installations requiring a larger capacity it is preferable to use a plurality of hydraulic accumulators coupled in parallel and with a common high pressure gas source, e.g. a pressure bottle filled with nitrogen gas.

The invention shall in the following be described in more detail, with reference to exemplifying preferred embodiments shown in the attached drawings in which:



Figures 1, 2 and 3 illustrate the different stages of a fire extinguishing procedure in a room.

Figures 4, 5 and 6 illustrate the corresponding situations in a hydraulic accumulator utilized as a drive unit.

Figures 7, 8 and 9 show three embodiments of drive units having a relatively large capacity.

Figure 10 shows an application of the invention, for a larger space, such as a restaurant room.

In figures 1, 2 and 3, a room is indicated by the reference numeral 1. In the ceiling of the room 1 is mounted a spray head or sprinkler 2 with e.g. four nozzles 3 directed obliquely outwards and downwards.

When water only is sprayed at a drive pressure e.g. from about 200 bar to about 120 bar, a concentrated fog-like liquid spray 4 is obtained which is capable of striking through rising smoke gases down to the floor of the room to extinguish, or at least suppress even a violent fire at the floor level.

A concentrated fog-like liquid spray 4 is obtained by means of a certain combination of the mutual distance between the nozzles of the spray head or sprinkler 2, of the direction of the nozzles 3, of the outlets of the nozzles 3 which determine the droplet size, and of the drive pressure of the liquid. At the right combination of these factors, which combination, due to the absence of a reliable theory and formula, can be determined by experiments, there is produced a suction which keeps the fog-like liquid spray together, as illustrated by arrows 5 and 6 in figure 1. It is hereby essential that air can be sucked in to the spray head 2 along the ceiling of the room, behind the nozzles 3 of the spray head, which means that the nozzles 3 should not be too close to the ceiling; a distance of about five centimetres is usually sufficient. Together with the air, arrows 5

and 6, smoke gases and carbon monoxide are sucked in to participate in fighting the fire when they follow along with the fog-like liquid spray 4.

5 In the situation illustrated in figure 1, there is thus a rather strong circulation of liquid fog and smoke gases from the floor of the room up to the ceiling and down again, but the effect near the ceiling, especially in the corner areas 7 where the walls and the ceiling meet, is somewhat limited; 10 smaller fires, e.g. cable fires, have a tendency to remain smouldering.

According to the invention it is therefore suggested that the concentrated fog-like liquid spray 4 is scattered after a predetermined time, by breaking 15 the aforementioned combination necessary in order to obtain the concentrated spray 4, by mixing a high pressure gas, preferably nitrogen drive gas from one or a plurality of high pressure hydraulic accumulators forming a drive unit for the spray head 2, into the 20 liquid. Due to the thereby decreased droplet size, in combination with an at least momentarily increased velocity out of the nozzles 3, the suction indicated by the arrows 5 and 6 is weakened so much, that the spray is no longer held together and instead is 25 obtained a more spread liquid fog configuration, as indicated by the arrows 8 in figure 2. The high flow velocity and the reflection from the walls of the room result in a strong turbulence, indicated by 4a in figure 2, as well as a finely distributed liquid fog, 30 shown in grey colour and indicated by 9 in figure 2.

As long as the amount of gas fed into the extinguishing liquid is comparatively small, as in 35 figure 2, the finely distributed liquid fog 9, which is effective in finally extinguishing rather small fires in general, and smouldering fires in particular, has certain difficulties in reaching into the corner

areas up in the room.

This problem is solved by, in a third step, feeding a larger amount of gas into the extinguishing liquid, said third step being illustrated in figure 3. When hydraulic accumulators are used as drive unit for the spray head or sprinkler 2, the third step can be commenced when the drive pressured has decreased to about 70 bar. The fog-like liquid sprays are now spread out further, the turbulence 4b is weakened more, and the finely distributed liquid fog 9 can fill even the corner areas 7 up in the room, especially when using a mixing gas lighter than air, such as e.g. nitrogen gas. The nitrogen gas then gradually accumulates at the ceiling, as indicated by arrows 10 in figure 3, and brings along small droplets. Nitrogen gas alone has a smothering effect which is improved by the water droplets which have a cooling effect also.

In figures 4-6 a hydraulic accumulator is generally indicated by the reference numeral 11. The hydraulic accumulator comprises a pressure container 12 with an inlet 13 for compressed gas, e.g. nitrogen gas, and an outlet 14 for connection to an outgoing line or hose.

In the container 12 is arranged a tube 15 with an inlet 16 near the bottom of the container and with the opposite end connected to the outlet 14. The pipe 15 has two apertures 17 and 18 in its wall, at different levels in such a manner that the aperture 17 is relatively far from the tube inlet 16 whereas the aperture 18 is considerably closer to the tube inlet 16. The reference numeral 19 indicates a gas space, 20 indicates water, 21 indicates the water surface, or water level, and 22 indicates a manometer.

In the state of readiness, the container 12 is to a great extent filled with liquid, preferably water, i.e. the gas space is small and the gas pressure is

high. An outlet valve provided in the outgoing line, not shown, is closed.

When the extinguisher is activated, the high pressure drive gas starts driving the water out through the pipe 15 to the outlet 14 and further to at least one spray head or sprinkler to produce a fog-like liquid spray having a droplet size of typically 50 to 150 microns and capable of penetrating hot smoke gases generated by the fire, in order to at least suppress the fire.

The water level gradually sinks in the container 12 whereas the gas space 19 becomes larger, correspondingly, and the gas pressure falls. In figure 4 the water level 11 has not yet reached the aperture 17 in the wall of the tube 5 and the hydraulic accumulator delivers water only. If the initial charge pressure of the hydraulic accumulator is about 200 bar, the aperture 17 can preferably be positioned so that the gas pressure of the accumulator has decreased to e.g. about 120 bar when the the water level reaches the aperture 17.

In figure 5 the water level has passed the wall aperture 17 of the tube 15 and gas flows through the aperture 17 into the water flow, as indicated in figure 5 by gas bubbles 23. Due to the intermixed gas, the size of the droplets in the fog-like liquid spray is reduced, and the spray loses its penetration power to such an extent that it takes the form of a turbulent water/gas-fog, which fills the fire room in a considerably more even manner as what the initially sprayed more concentrated fog spray did.

In figure 6 the water level has passed the second wall aperture 18 also, and more drive gas flows into the tube 15, as indicated by bubbles 24 in figure 6. It is of course possible to provide apertures in the tube wall at more than two levels and to provide a

plurality of apertures at each level. In general the desired effect is accomplished by a few small apertures having a diameter of e.g. 1 to 2 mm. The aperture 18 can be positioned such that the gas pressure of the hydraulic accumulator has decreased to about 70 bar when the water level reaches the aperture 18.

As the amount of gas mixed into the liquid increases in proportion to the amount of liquid, the droplet size will decrease further, as well as the turbulence of the liquid fog, which latter still remains sufficiently strong to fill the whole fire room essentially evenly with the liquid fog, especially if nitrogen gas is used as drive gas for the hydraulic accumulator. Since nitrogen gas is a little lighter than air, it will gradually rise towards the ceiling and thereby bring along liquid droplets.

By mixing drive gas in this manner into the flow of extinguishing liquid it is possible to maintain an effective liquid spray until the container 12 is practically completely empty, whereat the pressure of the drive gas has fallen considerably. The pressure fall of the drive gas is in figures 4-6 illustrated by the different positions of the indicator of the manometer 22.

In the embodiments of figures 7, 8 and 9, the drive unit of the fire-fighting equipment is generally indicated by 30. Three hydraulic accumulators are indicated by 31 and correspond to the accumulator 11 in figures 4-6, each accumulator 31 thus comprising an inner tube 32 like the tube 15 in figures 4-6, wall apertures included. The drive units 30 are in figures 7-9 in a state of readiness, i.e. the accumulators 31 are filled with liquid, numeral 33 in figure 7.

A common source of drive gas for the hydraulic

accumulators 31, in figures 7-9 a pressure container with nitrogen gas and a charge pressure of about 200 bar, is indicated by 34. Connection means for gas into the accumulators and for liquid and a mixture of liquid and gas, respectively, out of the accumulators are indicated by 35, a common outlet line for the accumulators is indicated by 36 and a pilot valve therein is indicated by 37. An automatic, e.g. electrically operated pilot valve for connecting the gas container 34 is indicated by 38, a manually operable valve for the same purpose is indicated by 39 and a valve for filling and possibly emptying the accumulators is indicated by 40.

The drive unit of figure 7 works in the same way as has been described in the foregoing with reference to figures 4-6.

The drive unit of figure 8 comprises an additional hydraulic accumulator indicated by 41 and in parallel with the accumulators 31, and like these having an inner tube 32 with wall apertures. The accumulator 41 has preferably nitrogen gas as drive gas, like the accumulators 31, but the charge pressure is relatively low, e.g. about 25 bar. This additional accumulator 41 is used for spraying liquid and a mixture of liquid and gas, respectively, through activated spray heads in the beginning of the extinguishing process, in order to cool these spray heads and secure that the lines to the spray heads are filled with liquid before commencing high pressure liquid spraying.

In the drive unit of figure 9, a liquid pump 43 takes care of cooling the spray heads and filling the lines to them before spraying high pressure liquid. The pump 43 can further be used for refilling the hydraulic accumulators when emptied, preferably with a simultaneous cooling spray to the fire seat.

In the embodiments of figures 7 to 9 it is possible to, instead of a separate gas container 34 in common for the accumulators 31, have the accumulators 31 made as the accumulator 11 in figures 4 to 6.

5 Figure 10 shows an application of the invention for a larger space, such as a restaurant room, which in figure 10 is viewed from above and is indicated by 50. The room is monitored by a number of groups of spray heads, the action area of one such group is in figure 10 shown in grey colour. A group comprises a 10 number of activating, or primary spray heads or sprinklers 51 and a preferably somewhat greater number of secondary spray heads 52. When a primary spray head 51 is activated as a result of a fire withing its action area, all spray heads of that 15 particular group are activated by means of a governor valve 53, e.g. in the way as presented in the international patent application PCT/FI92/00316. Those spray heads which are positioned along the periphery of the action area of the group bar the action area 20 off from the rest of the restaurant room by producing curtains of liquid fog. Within the thus restricted area the function is essentially the same as described in the foregoing.

CLAIMS:

1. A method for fighting fire, in particular in a room, comprising:

5 spraying a liquid spray having comparatively large droplets and a good penetration power in order to at least suppress the fire; and

spraying a scattered spray comprising a mixture of liquid and a non-combustible gas in order to extinguish smouldering fire seats, characterized in that

10 a high pressure of up to 300 bar is used for creating the liquid spray, whereby the droplets are sprayed as a fog-like liquid spray which is produced from nozzles having a combination of mutual distance, spray direction and outlets that, together with said high pressure, produce a suction which keeps the fog-like liquid sprays of the nozzles together as a concentrated fog-like liquid spray, whereafter

20 the spraying of the fog-like liquid concentrated spray is stopped by lowering the pressure and by adding the non-combustible gas to the liquid to be sprayed from the nozzles, whereby a scattered spray in the form of a turbulent liquid fog is formed.

25 2. A method as claimed in claim 1, wherein the concentrated fog-like liquid spray is scattered by intermixing therein a gas which is lighter than air, so that the intermixed gas rises and brings liquid droplets towards the ceiling of the room, in order to ensure that fire seats in the upper regions of a room are extinguished by the combined effect of the gas itself and of the liquid droplets following with the gas.

30 3. A method as claimed in claim 2, wherein the concentrated fog-like liquid spray is scattered by intermixing therein nitrogen gas.

35 4. A method as claimed in claim 3 wherein the nitrogen gas is drive gas from at least one hydraulic high pressure accumulator.

5. Method as claimed in claim 1, wherein the concentrated fog-like liquid spray is scattered by intermixing therein argon gas.

6. An installation for fighting fire, in particular a fire in a room, comprising a spray head producing a



liquid spray, and a drive unit, having at least one hydraulic accumulator with an outlet connected to the spray head, the accumulator comprising a liquid space and gas space, whereby the liquid is arranged to be driven
 5 out through a tube which starts at the bottom portion of the liquid space and extends through the gas space to the outlet, whereby the tube has at least one aperture in its wall, at a predetermined distance from the outlet end of the tube and with a predetermined diameter, so that drive
 10 gas flows into the tube through said at least one aperture in the wall, when the liquid level in the hydraulic accumulator has descended to said aperture, in order to thereby intermix with the liquid and thus produce a scattered spray, characterized in that the
 15 spray head has nozzles capable of producing fog-like sprays at high operating pressure, whereby the nozzles have a combination of mutual distance, spray direction and outlets, which in combination, together with a high pressure of up to 300 bar, produces a suction which keeps
 20 the fog-like liquid sprays of the nozzles together as a concentrated fog-like liquid spray with good penetration power.

7. An installation as claimed in claim 6, wherein the tube has a plurality of apertures in its wall at
 25 different levels, so that as the gas pressure of the hydraulic accumulator decreases, the amount of drive gas mixed into the extinguishing liquid increases.

8. Installation as claimed in claim 6 or claim 7, wherein the drive gas is nitrogen gas with an initial
 30 charge pressure of about 200 bar.

9. An installation as claimed in any one of claims 6 to 8, wherein the drive unit comprises a plurality of hydraulic accumulators coupled in parallel and wherein a source of high pressure gas is arranged to deliver drive
 35 gas to the hydraulic accumulators in common.

10. An installation as claimed in claim 9 further comprising a plurality of spray heads, wherein the drive unit comprises at least one additional hydraulic accumulator, or a pump coupled in parallel with the other hydraulic accumulators and having a relatively low drive pressure and arranged to deliver liquid and liquid and



gas, respectively, in an initial stage of an extinguishing process, in order to fill an outgoing line with liquid and to cool spray heads and nozzles, respectively, before initiating spray with high pressure liquid.

5
10
11. An installation as claimed in claim 10, wherein a pressure guard for, at a predetermined reduced drive pressure in the line going out from said additional hydraulic accumulator to the fire seat, effecting connection from the pressure gas source to the other parallel hydraulic accumulators is provided.

12. A method of fighting fire substantially as herein described with reference to the accompanying drawings.

15
13. An installation for fighting fire substantially as herein described with reference to the accompanying drawings.

Dated this 13th day of November 1996

Göran Sundholm

By his Patent Attorneys

GRIFFITH HACK

20



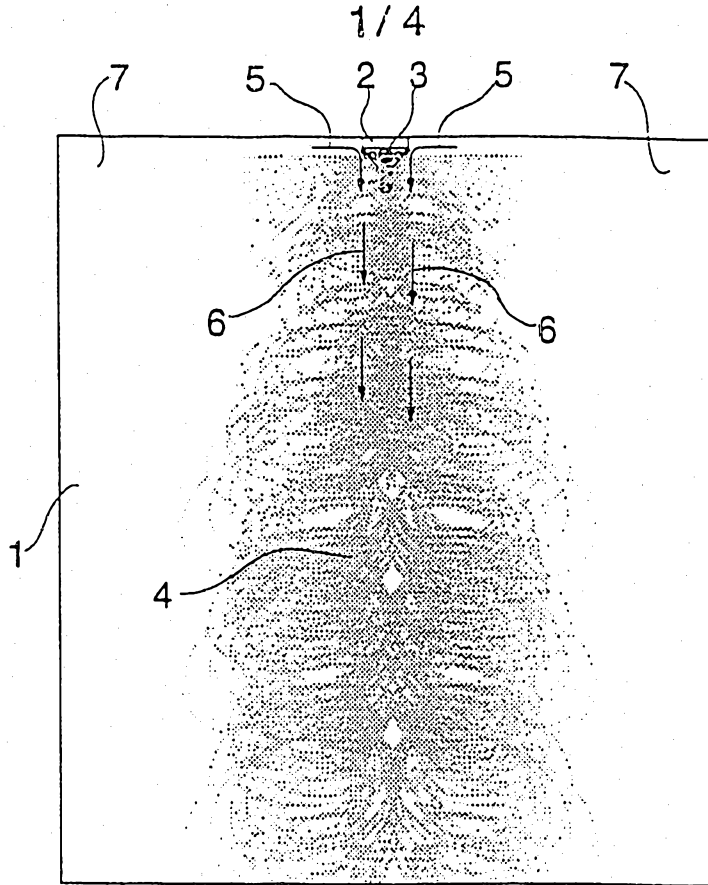

Fig. 1

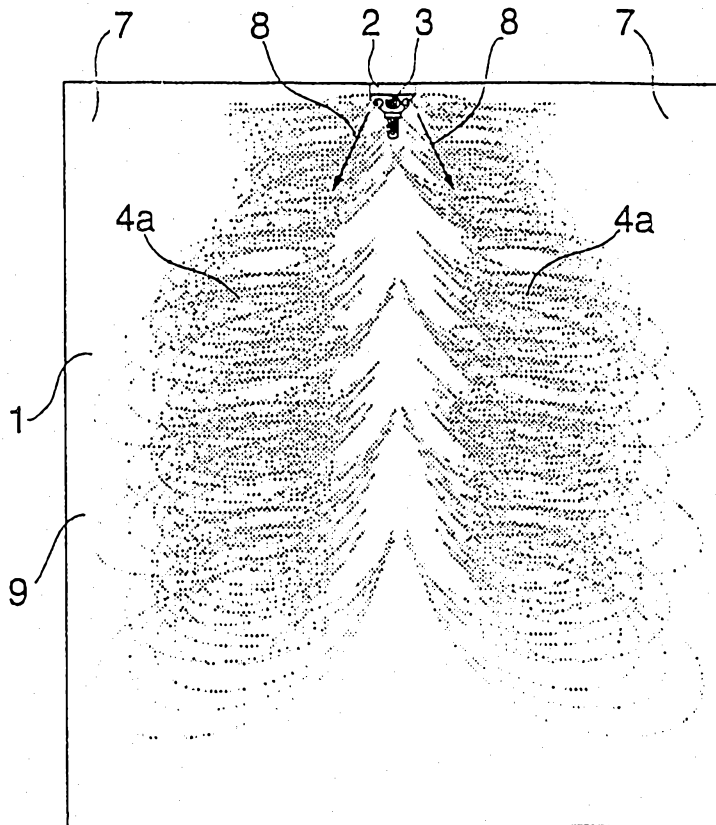

Fig. 2

2 / 4

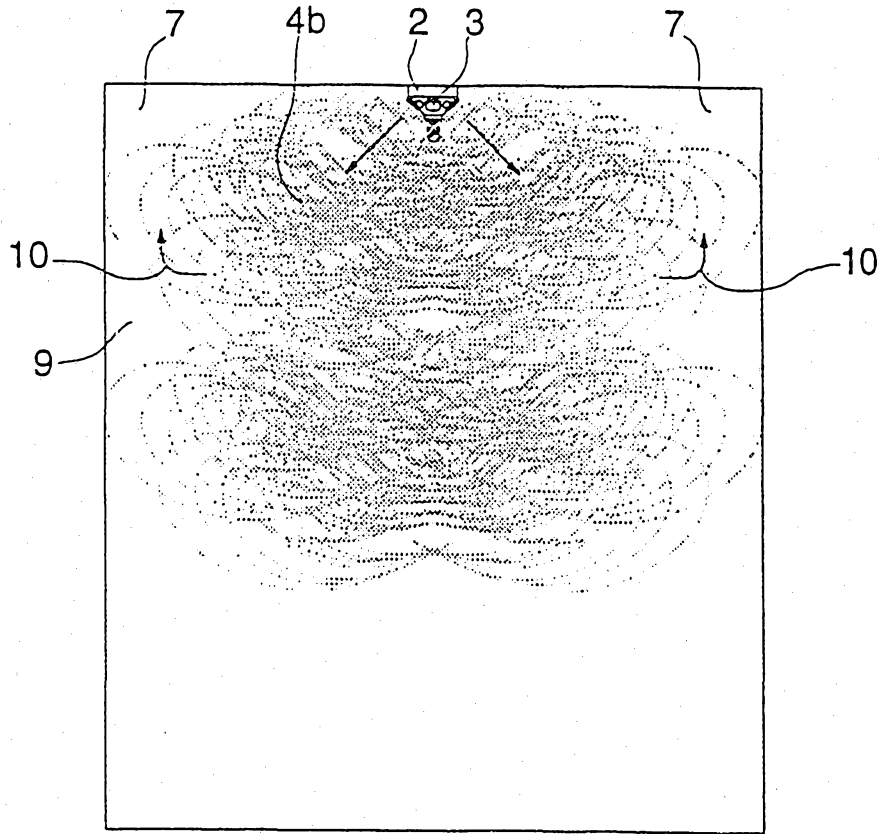

Fig. 3

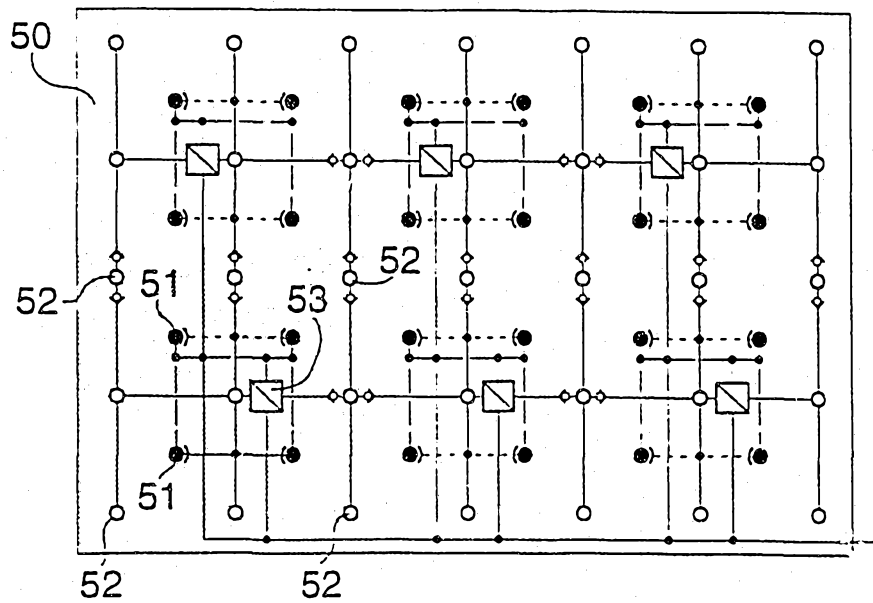

Fig. 10

51516/93

3 / 4

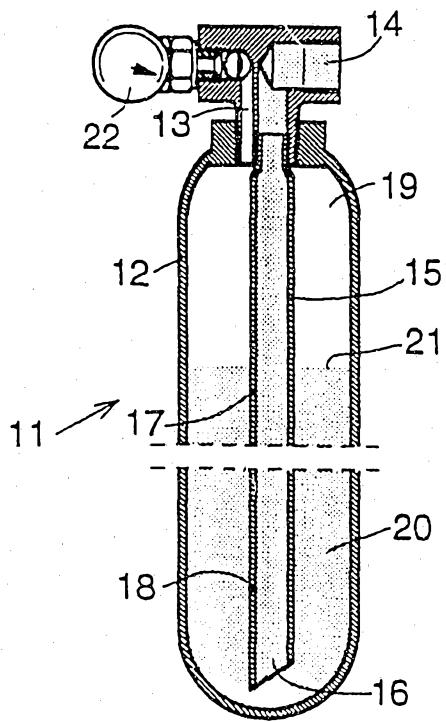

Fig. 4

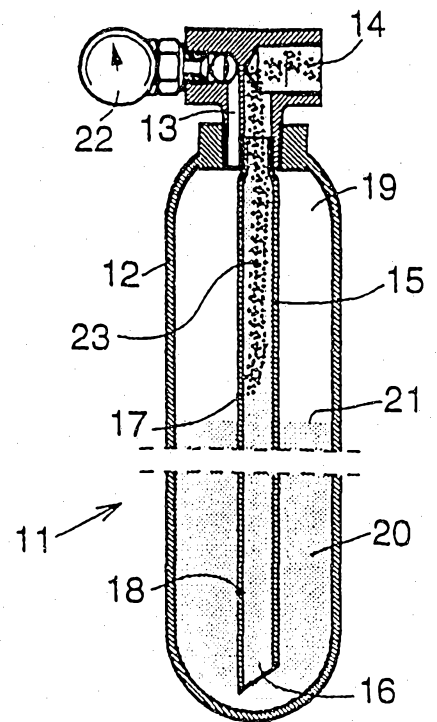

Fig. 5

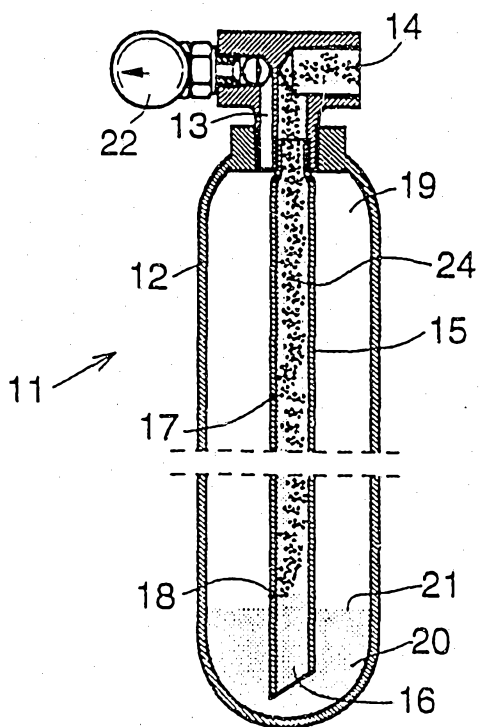

Fig. 6

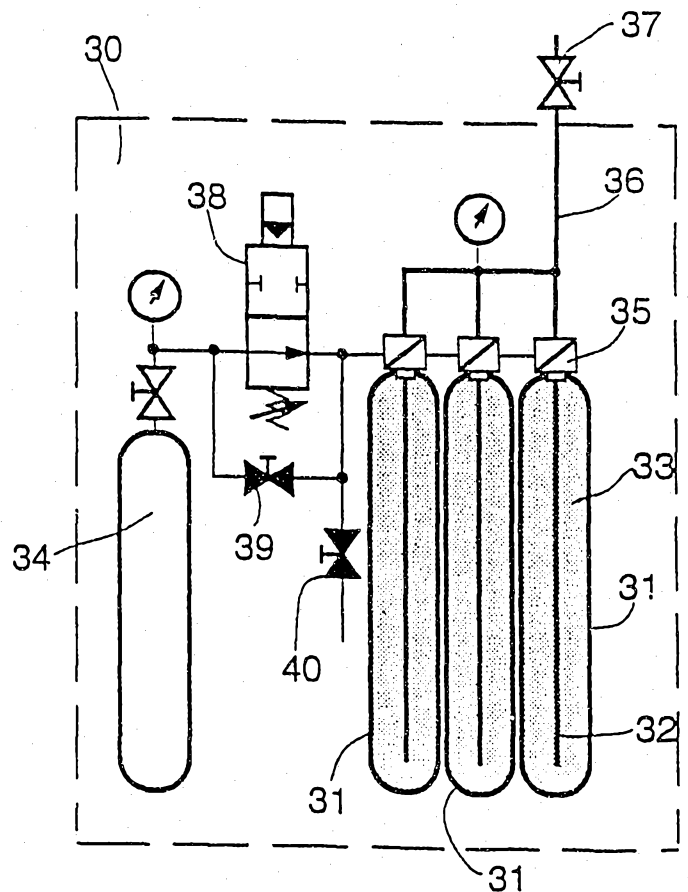

Fig. 7

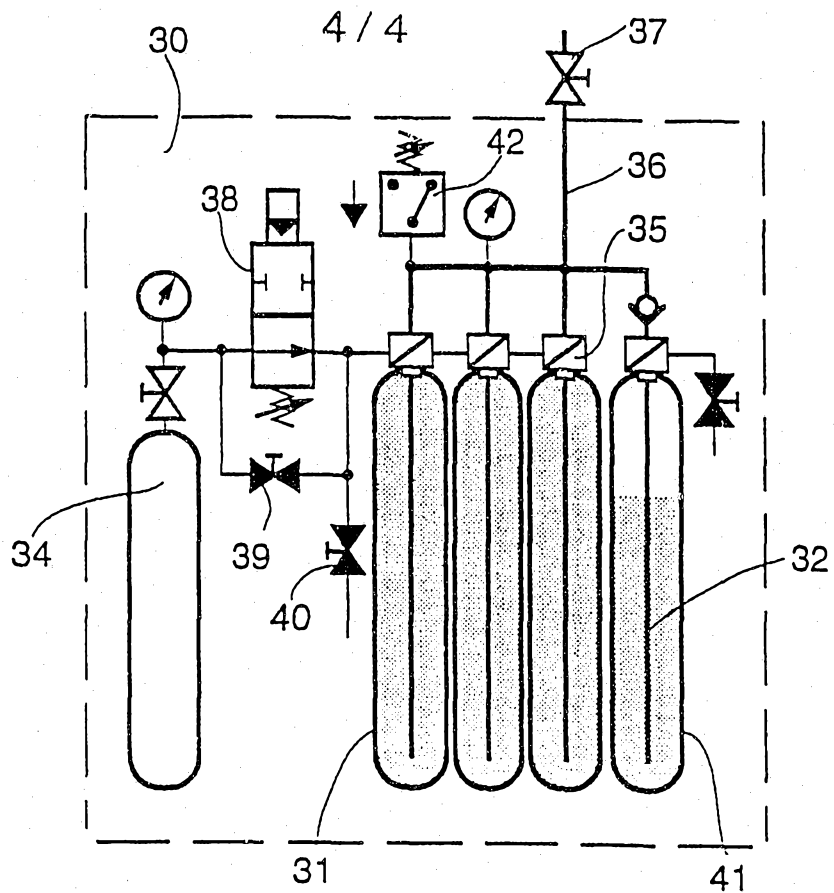

Fig. 8

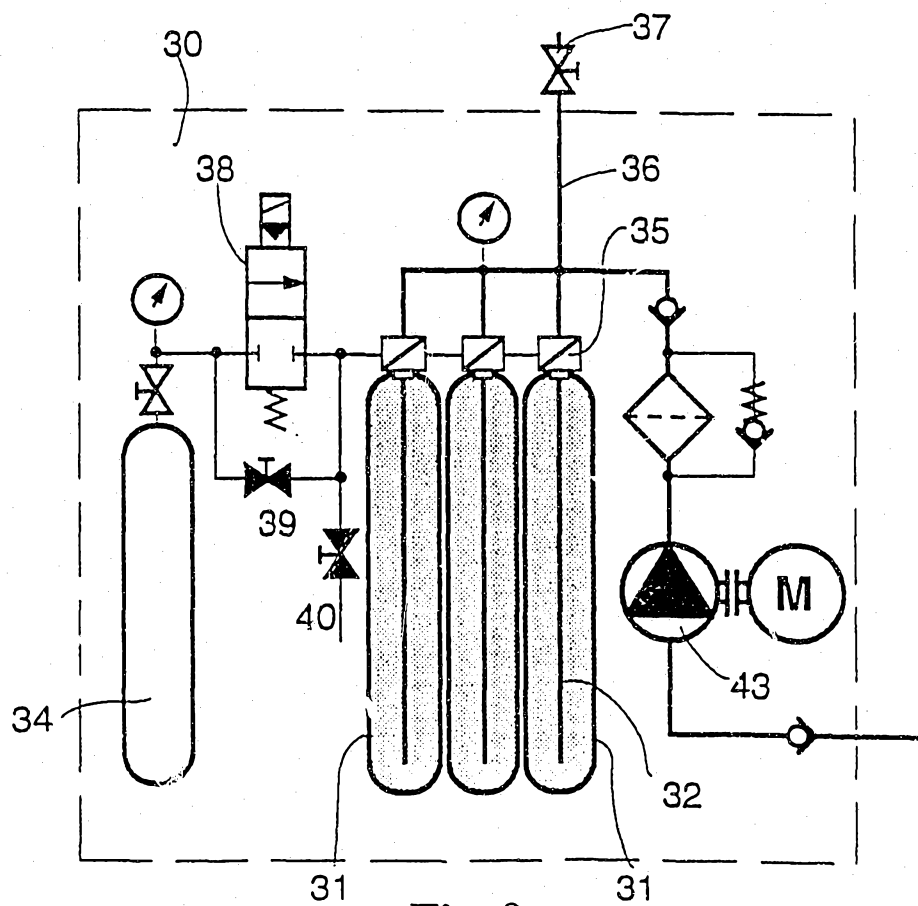

Fig. 9

INTERNATIONAL SEARCH REPORT

 International application No.
 PCT/FI 93/00429

A. CLASSIFICATION OF SUBJECT MATTER		
IPC5: A62C 3/00, A62C 13/62, A62C 35/00, A62C 35/62 According to International Patent Classification (IPC) or to both national classification and IPC		
B. FIELDS SEARCHED		
Minimum documentation searched (classification system followed by classification symbols)		
IPC5: A62C		
Documentation searched other than minimum documentation to the extent that such documents are included in the fields searched		
SE,DK,FI,NO classes as above		
Electronic data base consulted during the international search (name of data base and, where practicable, search terms used)		
DIALOG		
C. DOCUMENTS CONSIDERED TO BE RELEVANT		
Category*	Citation of document, with indication, where appropriate, of the relevant passages	Relevant to claim No.
X	Derwent's abstract, No 81-J4581D/37, week 8137, ABSTRACT OF SU, 1225585 (FEUER WSCHGERA NEURUPPIN (KWIA)), 23 April 1986 (23.04.86)	1,5,6
	--	
X	US, A, 1263291 (W.C. SCHULTZ), 16 April 1918 (16.04.18)	1,5,6
	--	
X	WO, A1, 9100122 (KIDDEGRAVINER LIMITED), 10 January 1991 (10.01.91), abstract	1
	--	
A	Derwent's abstract, No 91- 20210/03, week 9103, ABSTRACT OF SU, A1, 1563712 (KOROVIN V I), 15 May 1990 (15.05.90)	1,3,4
	--	
<input checked="" type="checkbox"/> Further documents are listed in the continuation of Box C. <input checked="" type="checkbox"/> See patent family annex.		
* Special categories of cited documents: "A" document defining the general state of the art which is not considered to be of particular relevance "E" earlier document but published on or after the international filing date "L" document which may throw doubts on priority claim(s) or which is cited to establish the publication date of another citation or other special reason (as specified) "O" document referring to an oral disclosure, use, exhibition or other means "P" document published prior to the international filing date but later than the priority date claimed "T" later document published after the international filing date or priority date and not in conflict with the application but cited to understand the principle or theory underlying the invention "X" document of particular relevance: the claimed invention cannot be considered novel or cannot be considered to involve an inventive step when the document is taken alone "Y" document of particular relevance: the claimed invention cannot be considered to involve an inventive step when the document is combined with one or more other such documents, such combination being obvious to a person skilled in the art "&" document member of the same patent family		
Date of the actual completion of the international search		Date of mailing of the international search report
10 February 1994		11 -02- 1994
Name and mailing address of the ISA/ Swedish Patent Office Box 5055, S-102 42 STOCKHOLM Facsimile No. +46 8 666 02 86		Authorized officer Ulrika Öhman Telephone No. +46 8 782 25 00

INTERNATIONAL SEARCH REPORT

International application No.
PCT/FI 93/00429

C (Continuation). DOCUMENTS CONSIDERED TO BE RELEVANT		
Category*	Citation of document, with indication, where appropriate, of the relevant passages	Relevant to claim No.
A	WO, A1, 9107208 (KIDDEGRAVINER LIMITED), 30 May 1991 (30.05.91), see page 17, 2:nd paragraph - page 18, 2:nd paragraph and page 19, 3:rd paragraph --	2
A	EP, A1, 0107837 (WORMALD FIRE SYSTEMS INC.), 9 May 1984 (09.05.84), abstract --	8
A	Derwent's abstract, No 92-182185/22, week 9222, ABSTRACT OF SU, A1, 1674865 (BALAGIN P G), 7 Sept 1991 (07.09.91) --	8
P,A	WO, A1, 9222353 (SUNDHOLM, GÖRAN), 23 December 1992 (23.12.92), page 9, line 18 - line 25 -- -----	9,10

INTERNATIONAL SEARCH REPORT

Information on patent family members

30/12/93

International application No. PCT/FI 93/00429
--

Patent document cited in search report	Publication date	Patent family member(s)	Publication date
US-A- 1263291	16/04/18	NONE	
WO-A1- 9100122	10/01/91	AU-A- 5832090 EP-A- 0478625	17/01/91 08/04/92
WO-A1- 9107208	30/05/91	EP-A- 0500666	02/09/92
EP-A1- 0107837	09/05/84	AU-B- 553816 AU-A- 1930783 CA-A- 1152857 US-A- 4520871	31/07/86 10/05/84 30/08/83 04/06/85
WO-A1- 9222353	23/12/92	AU-A- 1327192 AU-A- 1971492 WO-A- 9215370	06/10/92 12/01/93 17/09/92