



- (51) International Patent Classification:
B66B 9/04 (2006.01) *B66B 11/02* (2006.01)
- (21) International Application Number:
PCT/IB2021/054739
- (22) International Filing Date:
31 May 2021 (31.05.2021)
- (25) Filing Language: English
- (26) Publication Language: English
- (30) Priority Data:
202041023098 02 June 2020 (02.06.2020) IN
- (72) Inventor; and
(71) Applicant: **BABU, Killakathu Ramanathan** [IN/IN]; No
11, Lb Road, Adyar, Tamilnadu, Chennai 600 020 (IN).
- (74) Agent: **AGRAWAL, Dinkar**; IPExcel, Indiqube Orion,
24th Main Rd, Garden Layout, Sector 2, Hsr Layout, Kar-
nataka, Bangalore 560102 (IN).
- (81) Designated States (unless otherwise indicated, for every
kind of national protection available): AE, AG, AL, AM,
AO, AT, AU, AZ, BA, BB, BG, BH, BN, BR, BW, BY, BZ,
CA, CH, CL, CN, CO, CR, CU, CZ, DE, DJ, DK, DM, DO,
DZ, EC, EE, EG, ES, FI, GB, GD, GE, GH, GM, GT, HN,
HR, HU, ID, IL, IN, IR, IS, IT, JO, JP, KE, KG, KH, KN,
KP, KR, KW, KZ, LA, LC, LK, LR, LS, LU, LY, MA, MD,
ME, MG, MK, MN, MW, MX, MY, MZ, NA, NG, NI, NO,
NZ, OM, PA, PE, PG, PH, PL, PT, QA, RO, RS, RU, RW,
SA, SC, SD, SE, SG, SK, SL, ST, SV, SY, TH, TJ, TM, TN,
TR, TT, TZ, UA, UG, US, UZ, VC, VN, WS, ZA, ZM, ZW.
- (84) Designated States (unless otherwise indicated, for every
kind of regional protection available): ARIPO (BW, GH,
GM, KE, LR, LS, MW, MZ, NA, RW, SD, SL, ST, SZ, TZ,

(54) Title: AN INTEGRATED NOISE SUPPRESSION APPARATUS FOR A PNEUMATIC VACUUM ELEVATOR

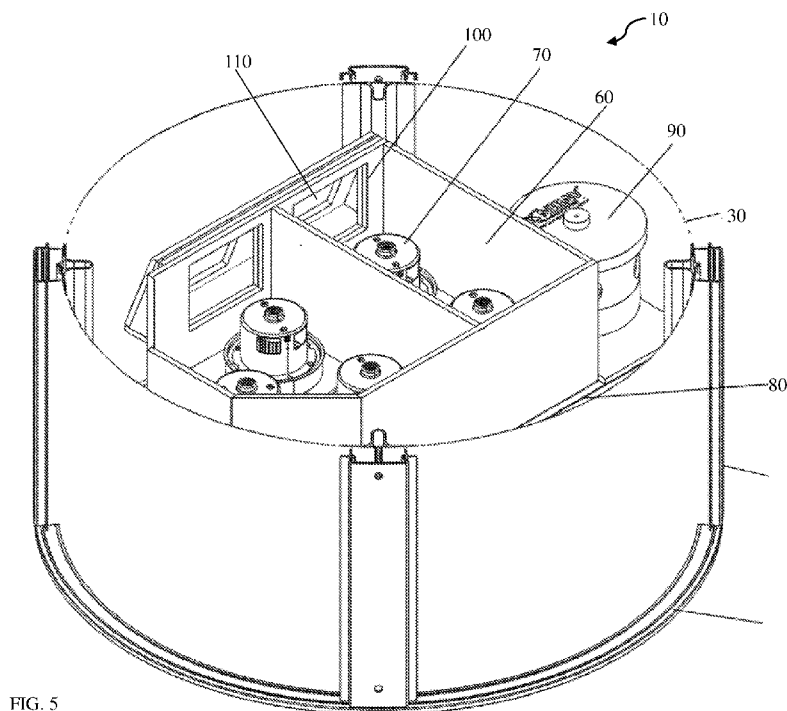

FIG. 5

(57) Abstract: An integrated noise suppression apparatus for a pneumatic vacuum elevator is provided. The apparatus includes an equipment compartment which includes a first partition unit vertically surrounding one or more electric motors configured to suck air from elevator cylinders and release the air into atmosphere, a bottom plate comprising a channel, wherein a pneumatic flow control unit placed on top of the bottom plate configured to allow air from the atmosphere into the elevator cylinders, a second partition unit, a silencer unit which includes a first layer placed configured to initiate the circulation of air, a second layer having a first set of partition strips, a third layer having a second set of partition strips, a fourth layer, a fifth layer having a third set of partition strips. A plurality of layers is arranged one above the other to enable the air to pass between the atmosphere and the tubular cylinder.



WO 2021/245524 A1

UG, ZM, ZW), Eurasian (AM, AZ, BY, KG, KZ, RU, TJ, TM), European (AL, AT, BE, BG, CH, CY, CZ, DE, DK, EE, ES, FI, FR, GB, GR, HR, HU, IE, IS, IT, LT, LU, LV, MC, MK, MT, NL, NO, PL, PT, RO, RS, SE, SI, SK, SM, TR), OAPI (BF, BJ, CF, CG, CI, CM, GA, GN, GQ, GW, KM, ML, MR, NE, SN, TD, TG).

Declarations under Rule 4.17:

- *as to the identity of the inventor (Rule 4.17(i))*
- *as to applicant's entitlement to apply for and be granted a patent (Rule 4.17(ii))*
- *as to the applicant's entitlement to claim the priority of the earlier application (Rule 4.17(iii))*

Published:

- *with international search report (Art. 21(3))*
- *in black and white; the international application as filed contained color or greyscale and is available for download from PATENTSCOPE*

AN INTEGRATED NOISE SUPPRESSION APPARATUS FOR A PNEUMATIC VACUUM ELEVATOR

This International Application claims priority from a Complete patent application filed in India having Patent Application No. 202041023098, filed on June 02, 2020,
5 and titled “AN INTEGRATED NOISE SUPPRESSION APPARATUS FOR A PNEUMATIC VACUUM ELEVATOR”.

FIELD OF INVENTION

Embodiments of the present disclosure relate to noise suppression in a pneumatic vacuum elevator, and more particularly, to an integrated noise suppression
10 apparatus for a pneumatic vacuum elevator.

BACKGROUND

An elevator is a vertical transportation machine which is used to move people between floors of a structure. Among such elevators, pneumatic vacuum elevators are a type of elevator which uses air pressure to lift the elevator cab. The cab has a
15 vacuum seal built into the ceiling. A challenge which arises is to maintain noise level of the elevator when being operated. In a conventional approach, where the pneumatic vacuum elevators are to be installed in any of the commercial locations or home, noise suppression unit is to be mounted independently. However, in such an approach, there may be a situation where the noise suppression unit which needs
20 to be mounted on top of the elevator unit would not fit into the location; thus, the installation could not be accomplished, thereby making such approaches non-reliable and less efficient. Also, a level of suppression of noise in such approaches is a challenge, specially within the indoor environment.

Hence, there is a need for an improved integrated noise apparatus for a pneumatic
25 vacuum elevator to address the aforementioned issues.

BRIEF DESCRIPTION

In accordance with the present disclosure, an integrated noise suppression apparatus for a pneumatic vacuum elevator is provided. The apparatus includes an equipment compartment mounted on top a top cylinder of one or more vertically stacked elevator cylinders. The equipment compartment includes a first partition unit vertically surrounding one or more electric motors housed inside the equipment compartment. The one or more electric motors are configured to suck air from one or more vertically stacked elevator cylinders and release the air into atmosphere surrounding the equipment compartment cylindrical body to operate the pneumatic vacuum elevator in upward direction. The apparatus also includes a bottom plate comprising a channel positioned outside the first partition unit, wherein a pneumatic flow control unit placed on top of the bottom plate. The pneumatic flow control unit is configured to allow air from the atmosphere into the corresponding one or more elevator cylinders to operate the pneumatic vacuum elevator in downward direction. The apparatus also includes a second partition unit mechanically coupled to the first partition unit, wherein the second partition unit includes an opening in a pre-defined shape. The second partition unit is configured to circulate air between the equipment compartment and the atmosphere upon being sucked or released by the one or more electric motors or the pneumatic flow control unit respectively. The apparatus also includes a silencer unit placed below the one or more electric motors and the pneumatic flow control unit. The silencer unit includes a first layer placed upon the bottom plate and above the tubular cylinder. The first layer includes first set of partition strips arranged in a pre-defined fashion, wherein each of the first set of partition strips comprises a corresponding plurality of square cut-outs arranged in a first pre-defined fashion. The first layer is configured to initiate the circulation of air. The silencer unit also includes a second layer placed above the first layer, wherein the second layer includes a second set of partition strips arranged in a pre-defined fashion. Each of the first set of partition strips includes a corresponding plurality of square cut-outs arranged in a second pre-defined fashion. The silencer unit also includes a third layer placed above the second layer. The third layer includes a third set of partition strips arranged in a third pre-defined fashion. Each of the third set of partition strips comprises a corresponding plurality of square cut-

outs arranged in a third pre-defined fashion. The silencer unit also includes a fourth layer placed above the third layer. The fourth layer includes a fourth set of partition strips arranged in a fourth pre-defined fashion. Each of the fourth set of partition strips comprises a corresponding plurality of square cut-outs arranged in a fourth pre-defined fashion. The silencer unit also includes a fifth layer placed above the fourth layer. The fourth layer includes a fifth set of partition strips. Each of the fifth set of partition strips includes a corresponding plurality of circular cut-outs arranged in a fifth pre-defined fashion. The plurality of circular cut-outs is structured to position the corresponding one or more electric motors. A plurality of layers is arranged one above the other to enable the air to pass between the atmosphere and the tubular cylinder via the plurality of layers. An arrangement of the first set of partition strips, the second set of partition strips and the third set of partition strips forms a pre-defined structure configured to absorb noise developed during operation of the pneumatic vacuum elevator upon air being circulated sequentially from the first layer to the fifth layer.

In accordance with another embodiment of the present disclosure, a pneumatic vacuum elevator is provided. The pneumatic vacuum elevator includes one or more vertically stacked elevator cylinders configured to enable one or more users to move between a plurality of floors of a multi-storied building. The pneumatic vacuum elevator also includes an integrated noise suppression apparatus integrated on top of the one or more elevator cylinders. The integrated noise suppression apparatus includes an equipment compartment mounted on top a top cylinder of one or more vertically stacked elevator cylinders. The equipment compartment includes a first partition unit vertically surrounding one or more electric motors housed inside the equipment compartment. The one or more electric motors are configured to suck air from one or more vertically stacked elevator cylinders and release the air into atmosphere surrounding the equipment compartment cylindrical body to operate the pneumatic vacuum elevator in upward direction. The apparatus also includes a bottom plate comprising a channel positioned outside the first partition unit, wherein an pneumatic flow control unit placed on top of the bottom plate. The

pneumatic flow control unit is configured to allow air from the atmosphere into the corresponding one or more elevator cylinders to operate the pneumatic vacuum elevator in downward direction. The apparatus also includes a second partition unit mechanically coupled to the first partition unit, wherein the second partition unit includes an opening in a pre-defined shape. The second partition unit is configured to circulate air between the equipment compartment and the atmosphere upon being sucked or released by the one or more electric motors or the pneumatic flow control unit respectively. The apparatus also includes a silencer unit placed below the one or more electric motors and the pneumatic flow control unit. The silencer unit includes a first layer placed upon the bottom plate and above the tubular cylinder. The first layer includes first set of partition strips arranged in a pre-defined fashion, wherein each of the first set of partition strips comprises a corresponding plurality of square cut-outs arranged in a first pre-defined fashion. The first layer is configured to initiate the circulation of air. The silencer unit also includes a second layer placed above the first layer, wherein the second layer includes a second set of partition strips arranged in a pre-defined fashion. Each of the first set of partition strips includes a corresponding plurality of square cut-outs arranged in a second pre-defined fashion. The silencer unit also includes a third layer placed above the second layer. The third layer includes a third set of partition strips arranged in a third pre-defined fashion. Each of the third set of partition strips comprises a corresponding plurality of square cut-outs arranged in a third pre-defined fashion. The silencer unit also includes a fourth layer placed above the third layer. The fourth layer includes a fourth set of partition strips arranged in a fourth pre-defined fashion. Each of the fourth set of partition strips comprises a corresponding plurality of square cut-outs arranged in a fourth pre-defined fashion. The silencer unit also includes a fifth layer placed above the fourth layer. The fourth layer includes a fifth set of partition strips. Each of the fifth set of partition strips includes a corresponding plurality of circular cut-outs arranged in a fifth pre-defined fashion. The plurality of circular cut-outs is structured to position the corresponding one or more electric motors. A plurality of layers is arranged one above the other to enable the air to pass between the atmosphere and the tubular cylinder via the plurality of

layers. An arrangement of the first set of partition strips, the second set of partition strips and the third set of partition strips forms a pre-defined structure configured to absorb noise developed during operation of the pneumatic vacuum elevator upon air being circulated sequentially from the first layer to the fifth layer.

- 5 To further clarify the advantages and features of the present disclosure, a more particular description of the disclosure will follow by reference to specific embodiments thereof, which are illustrated in the appended figures. It is to be appreciated that these figures depict only typical embodiments of the disclosure and are therefore not to be considered limiting in scope. The disclosure will be described
10 and explained with additional specificity and detail with the appended figures.

BRIEF DESCRIPTION OF DRAWINGS

The disclosure will be described and explained with additional specificity and detail with the accompanying figures in which:

- 15 FIG. 1 is a schematic representation of an overall pneumatic vacuum elevator system comprising an integrated noise suspension unit in accordance with an embodiment of the present disclosure;

FIG. 2 is a schematic representation of the pneumatic vacuum elevator system moving in upward direction of FIG. 1 in accordance with an embodiment of the present disclosure;

- 20 FIG. 3 is a schematic representation of the pneumatic vacuum elevator system moving in downward direction of FIG. 1 in accordance with an embodiment of the present disclosure;

FIG. 4 is an isometric representation of an integrated noise suppression unit of FIG. 1 in accordance with an embodiment of the present disclosure;

FIG. 5 is an isometric representation of an assemble section of the integrated noise suppression unit of FIG. 1 in accordance with an embodiment of the present disclosure;

5 FIG. 6a is schematic representation of a first layer of a silencer unit of the integrated noise suppression unit of FIG. 1 in accordance with an embodiment of the present disclosure;

FIG. 6b is schematic representation of a second layer of the silencer unit of the integrated noise suppression unit of FIG. 1 in accordance with an embodiment of the present disclosure;

10 FIG. 6c is schematic representation of a third layer of the silencer unit of the integrated noise suppression unit of FIG. 1 in accordance with an embodiment of the present disclosure;

15 FIG. 6d is schematic representation of a fourth layer of the silencer unit of the integrated noise suppression unit of FIG. 1 in accordance with an embodiment of the present disclosure;

FIG. 6e is schematic representation of a fifth layer of the silencer unit of the integrated noise suppression unit of FIG. 1 in accordance with an embodiment of the present disclosure; and

20 FIG. 6f is schematic representation of all the layers of the silencer unit of the integrated noise suppression unit of FIG. 1 in accordance with an embodiment of the present disclosure.

Further, those skilled in the art will appreciate that elements in the figures are illustrated for simplicity and may not have necessarily been drawn to scale. Furthermore, in terms of the construction of the device, one or more components of
25 the device may have been represented in the figures by conventional symbols, and the figures may show only those specific details that are pertinent to understanding the embodiments of the present invention so as not to obscure the figures with

details that will be readily apparent to those skilled in the art having the benefit of the description herein.

DETAILED DESCRIPTION

For the purpose of promoting an understanding of the principles of the invention,
5 reference will now be made to the embodiment illustrated in the figures and specific language will be used to describe them. It will nevertheless be understood that no limitation of the scope of the invention is thereby intended. Such alterations and further modifications in the illustrated system, and such further applications of the principles of the invention as would normally occur to those skilled in the art are to
10 be construed as being within the scope of the present invention.

It will be understood by those skilled in the art that the foregoing general description and the following detailed description are exemplary and explanatory of the invention and are not intended to be restrictive thereof.

The terms "comprises", "comprising", or any other variations thereof, are intended
15 to cover a non-exclusive inclusion, such that a process or method that comprises a list of steps does not include only those steps but may include other steps not expressly listed or inherent to such a process or method. Similarly, one or more devices or sub-systems or elements or structures or components preceded by "comprises... a" does not, without more constraints, preclude the existence of other
20 devices, sub-systems, elements, structures, components, additional devices, additional sub-systems, additional elements, additional structures or additional components. Appearances of the phrase "in an embodiment", "in another embodiment" and similar language throughout this specification may, but not necessarily do, all refer to the same embodiment.

25 Unless otherwise defined, all technical and scientific terms used herein have the same meaning as commonly understood by those skilled in the art to which this invention belongs. The system, methods, and examples provided herein are only illustrative and not intended to be limiting.

Embodiments of the present disclosure relates to an integrated noise suppression apparatus for a pneumatic vacuum elevator. As used herein, the term “a pneumatic vacuum elevator” is defined as a kind of an elevator which works on air pressure to lift the elevator cab.

- 5 FIG. 1 is a schematic representation of an overall pneumatic vacuum elevator system (20) comprising an integrated noise suspension apparatus (10) in accordance with an embodiment of the present disclosure. The pneumatic vacuum elevator (10) includes one or more vertically stacked elevator cylinders (50) configured to enable one or more users to move between a plurality of floors of a multi-storied building.
- 10 The pneumatic vacuum elevator (20) also includes an integrated noise suppression apparatus (10) integrated on top of the one or more elevator cylinders (40, 50), hereafter referred to as apparatus.

Turing to FIG. 4 and FIG. 5, FIG. 4 is an isometric representation of the integrated noise suppression unit of FIG. 1 in accordance with an embodiment of the present disclosure. FIG. 5 is an isometric representation of an assemble section of the integrated noise suppression unit of FIG. 1 in accordance with an embodiment of the present disclosure. The apparatus (10) includes an equipment compartment (30) mounted on top of a cylinder of one or more vertically stacked elevator cylinders (65) resting on an elevator cabin (50). In one embodiment, the elevator cabin (50) may correspond to a cylinder (50) of the one or more elevator cylinders (50). More specifically, the pneumatic vacuum elevator (20) includes the one or more elevator cylinders (50) vertically stacked. The tubular cylinder (40) is stalked above one of the elevator cabin (50) and corresponds to a topmost cylinder of the one or more elevator cylinders (50). In one exemplary embodiment, the equipment compartment

20 may be composed of a Polycarbonate sheet. In another embodiment, the equipment compartment (30) may be fabricated of plastic, high-density polyethylene (HDPE), acrylic, medium-density fibreboard or any suitable material.

The apparatus (10) includes a first partition unit (60) vertically surrounding one or more electric motors (70) housed inside the equipment compartment (30). The first

partition unit (60) may be arranged in a pre-defined fashion. The one or more electric motors (70) is configured to suck air from one or more vertically stacked elevator cylinders (50) and release the air into atmosphere surrounding the equipment compartment (30) to operate the pneumatic vacuum elevator (20) in upward direction. In one exemplary embodiment, the first partition unit (60) may be composed of a material selected from a group consisting plywood, Medium-density fibreboard (MDF), particle board and solid wood.

The apparatus (10) also includes a bottom plate (80) which includes a channel (85) positioned outside the first partition unit (60). A pneumatic flow control unit (90) placed on top of the bottom plate (80). More specifically, the pneumatic flow control unit (90) is placed on the bottom plate (80). In one embodiment, the bottom plate (80) may be composed of metal such as steel, or the like. The pneumatic flow control unit (90) is configured to allow air from the atmosphere into the corresponding one or more elevator cylinders (50) to operate the pneumatic vacuum elevator (20) in downward direction. In one embodiment, the channel (85) may be a guide through passage which may be configured to fix the bottom plate (80) within the first partition unit (60).

Furthermore, the apparatus (0) includes a second partition unit (100) mechanically coupled to the first partition unit (60). The second partition unit (100) includes an opening in a pre-defined shape. In one embodiment the pre-defined shape of the opening may be circular, square, rectangular or the like. The second partition unit (100) is configured to circulate air between the equipment compartment (30) and the atmosphere upon being sucked or released by the one or more electric motors (70) or the pneumatic flow control unit (90) respectively. More specifically, the air between the atmosphere and the equipment compartment (30) is circulated via the second partition unit (100). In one exemplary embodiment, the second partition unit (100) may be composed of a material selected from a group consisting plywood, Medium-density fibreboard (MDF), particle board and solid wood.

The apparatus (10) also includes a silencer unit (120) placed below the one or more electric motors (70) and the pneumatic flow control unit (90). The silencer unit (120) includes a first layer (130) (as shown in FIG. 6a) placed upon the bottom plate (80) and above the tubular cylinder (40). The first layer (130) is configured to initiate the circulation of air. The first layer (130) includes first set of partition strips arranged in a pre-defined fashion. Each of the first set of partition strips comprises a corresponding plurality of square cut-outs arranged in a first pre-defined fashion. The first set of partition strips is configured to initiate the circulation of air.

The silencer unit (120) also includes a second layer (140) (as shown in FIG. 6b) placed above the first layer (130). The second layer (140) includes a second set of partition strips arranged in a second pre-defined fashion. Each of the second set of partition strips includes a corresponding plurality of square cut-outs arranged in the first pre-defined fashion. In one embodiment, the square cut-outs are positioned in a such way that the cut-outs do not overlap with the first set of partition strips of the first layer (130). More specifically, a bottom portion of the second layer is imposed with the second set of partition strips which is placed above the first layer in such a way that the first set of partition strips and the second set of partition strips sync with each other but do not overlap.

The silencer unit (120) also includes a third layer (150) (as shown in FIG. 6c) placed above the second layer (140). The third layer (150) includes a third set of partition strips arranged in a third pre-defined fashion. Each of the third set of partition strips comprises a corresponding plurality of square cut-outs arranged in a third pre-defined fashion. The silencer unit (120) also includes a fourth layer (160) (as shown in FIG. 6d) placed above the third layer (150). The fourth layer (160) includes a fourth set of partition strips arranged in a fourth pre-defined fashion. Each of the fourth set of partition strips comprises a corresponding plurality of square cut-outs arranged in a fourth pre-defined fashion. More specifically, a bottom portion of the fourth layer (160) is imposed with the fourth set of partition strips, which is placed above the third layer (150) to bring the third set of partition strips and the fourth set of partition strips in sync. Also, there exists a pre-defined amount of gap for the

flow of air between the top bottom surface of the fourth layer (160) and the third set of partition strips. Similarly, there exists a gap between the top surface of the third layer (150) and the fourth set of partition strips for the flow of air between the third layer (150) and the fourth layer (160).

5 The silencer unit (120) further includes a fifth layer (170) (as shown in FIG. 6e) placed above the fourth layer (160). The fifth layer (170) includes a fifth set of partition strips (180). Each of the fifth set of partition strips (180) which includes a corresponding plurality of circular cut-outs arranged in a fifth pre-defined fashion. The plurality of circular cut-outs is structured to position the corresponding one or
10 more electric motors (70). More specifically, the position of the corresponding plurality of circular cut-outs are in sync with the position of the corresponding one or more electric motors (70).

Further, a plurality of layers (190) (as shown in FIG. 6f) is arranged one above the other to enable the air to pass between the atmosphere and the tubular cylinder (40)
15 via the plurality of layers (190). The plurality of layers (190) corresponds to the first layer (130), the second layer (140), the third layer (150), the fourth layer (160) and the fifth layer (170) together. In one exemplary embodiment the first layer (130), the second layer (140), the third layer (150), the fourth layer (160) and the fifth layer (170) are padded with sound absorbing material. In such embodiment,
20 the sound absorbing material may be sound absorption foam.

An arrangement of the first set of partition strips, the second set of partition strips and the third set of partition strips forms a pre-defined structure configured to absorb noise developed during operation of the pneumatic vacuum elevator (20) upon air being circulated sequentially from the first layer (130) to the fifth layer
25 (170). In one exemplary embodiment, the first set of partition strips, the second set of partition strips, the third set of partition strips are padded with sound absorbing material. In such embodiment, the sound absorbing material may be sound absorption foam.

In one exemplary embodiment, the apparatus (10) may further include at least four vertical pillars (200) attached with corresponding plurality of outer rings (210). The plurality of outer rings (210) is integrated on an outer surface of the equipment compartment (30). In one exemplary embodiment, the apparatus (10) includes at least two outer rings (210), each of the at least two outer rings may be shaped of an arc, wherein an inner circumference of the arc may be equal to half of an outer circumference of the equipment compartment (30). Further, the at least four vertical pillars (200) may be configured to support the equipment compartment (30) and the plurality of outer rings (210). In one exemplary embodiment, the integrated noise suppression apparatus (10) may be located nearing to a roof (220) of a multi-storied building.

In operation, when the elevator cabin (40) is being operated in an ascending direction (as shown in in FIG. 2), that is when the elevator cabin (20) is moving in the upward direction, the air from the one or more elevator cylinders (50) are sucked by the one or more electric motors (70) via the plurality of layers (190), which is placed beneath the one or more electric motors (70). Air from the plurality of layers (190) passes through the second partition unit (100) and the air is released into the atmosphere. As the air passed through the plurality of layers (190) fabricated using the sound absorption foam, the noise generated by the pneumatic vacuum elevator (20) is reduced.

Also, in the scenario where the elevator cabin (50) is being operated in a descending direction (as shown in FIG. 3), that is when the elevator cabin (50) is moving in the downward direction, the air from the atmosphere is allowed into the elevator cabin (50) by the pneumatic flow control unit (90). The air from the atmosphere is allowed by the pneumatic flow control unit (90) to pass through the plurality of layers (190) fabricated using the sound absorption foam, the noise generated by the pneumatic vacuum elevator (50) is reduced.

Various embodiments of the disclosure enable the apparatus to enable the integration of the noise suppression unit along with the one or more one or more

elevator cylinders within the available space of the building. The structure of the layers used in the apparatus helps in reduction of noise while the pneumatic vacuum elevator is being operated.

5 While specific language has been used to describe the disclosure, any limitations arising on account of the same are not intended. As would be apparent to a person skilled in the art, various working modifications may be made to the method in order to implement the inventive concept as taught herein.

10 The figures and the foregoing description give examples of embodiments. Those skilled in the art will appreciate that one or more of the described elements may well be combined into a single functional element. Alternatively, certain elements may be split into multiple functional elements. Elements from one embodiment may be added to another embodiment. For example, the order of processes described herein may be changed and are not limited to the manner described herein. Moreover, the actions of any flow diagram need not be implemented in the order
15 shown; nor do all of the acts need to be necessarily performed. Also, those acts that are not dependent on other acts may be performed in parallel with the other acts. The scope of embodiments is by no means limited by these specific examples.

WE CLAIM:

1. An integrated noise suppression apparatus (10) for a pneumatic vacuum elevator (20) comprising:

an equipment compartment (30) mounted on top of a cylinder of one or more vertically stacked elevator cylinders (50), wherein the equipment compartment comprises:

a first partition unit (60) vertically surrounding one or more electric motors (70) housed inside the equipment compartment (30), wherein the one or more electric motors (70) are configured to suck air from one or more vertically stacked elevator cylinders (50) and release the air into atmosphere surrounding the equipment compartment (30) to operate the pneumatic vacuum elevator (20) in upward direction;

a bottom plate (80) comprising a channel (85) positioned outside the first partition unit (60), wherein a pneumatic flow control unit (90) placed on top of the bottom plate (80), wherein the pneumatic flow control unit (90) is configured to allow air from the atmosphere into the corresponding one or more elevator cylinders (50) to operate the pneumatic vacuum elevator (20) in downward direction;

a second partition unit (100) mechanically coupled to the first partition unit (60), wherein the second partition unit (100) comprises an opening (110) in a pre-defined shape, wherein the second partition unit (100) is configured to circulate air between the equipment compartment (30) and the atmosphere upon being sucked or released by the one or more electric motors (70) or the pneumatic flow control unit (90) respectively; and

a silencer unit (120) placed below the one or more electric motors (70) and the pneumatic flow control unit (90).

2. The integrated noise suppression apparatus (10) as claimed in claim 1, wherein the silencer unit (120) comprises:

5 a first layer (130) placed upon the bottom plate (80) and above the tubular cylinder (40), wherein the first layer (130) comprises a first set of partition strips arranged in a pre-defined fashion, wherein each of the first set of partition strips comprises a corresponding plurality of square cut-outs arranged in a first pre-defined fashion, wherein the first set of partition strips is configured to initiate the circulation of air;

10 a second layer (140) placed above the first layer (130), wherein the second layer (140) comprises a second set of partition strips arranged in a pre-defined fashion, wherein each of the second set of partition strips comprises a corresponding plurality of square cut-outs arranged in a second pre-defined fashion;

15 a third layer (150) placed above the second layer, wherein the third layer (150) comprises a third set of partition strips arranged in a third pre-defined fashion, wherein each of the third set of partition strips comprises a corresponding plurality of square cut-outs arranged in a third pre-defined fashion;

20 a fourth layer (160) placed above the third layer (150), wherein the fourth layer (160) comprises a fourth set of partition strips arranged in a fourth pre-defined fashion, wherein each of the fourth set of partition strips comprises a corresponding plurality of square cut-outs arranged in a fourth pre-defined fashion; and

25 a fifth layer (170) placed above the fourth layer, wherein the fifth layer (170) comprises a fifth set of partition strips (180), wherein each of the fifth set of partition strips (180) comprises a corresponding plurality of circular cut-outs arranged in a fifth pre-defined fashion, wherein the plurality of circular cut-outs are structured to position the corresponding one or more electric motors (70),

wherein a plurality of layers (190) is arranged one above the other to enable the air to pass between the atmosphere and the tubular cylinder (40) via the plurality of layers (190), and

5 wherein an arrangement of the first set of partition strips, the second set of partition strips and the third set of partition strips forms a pre-defined structure configured to absorb noise generated during operation of the pneumatic vacuum elevator (20) upon air being circulated sequentially from the first layer (130) to the fifth layer (170).

10 3. The integrated noise suppression apparatus (10) as claimed in claim 1, wherein equipment compartment (30) comprises at least one of Polycarbonate sheet, plastic sheet, acrylic sheet, High-density polyethylene (HDPE) sheet, medium-density fibreboard.

15 4. The integrated noise suppression apparatus (10) as claimed in claim 1, wherein the first layer (130), the second layer (140), the third layer (150), the fourth layer (160) and the fifth layer (170) are padded with sound absorbing material.

5 5. The integrated noise suppression apparatus (10) as claimed in claim 1, wherein the first set of partition strips, the second set of partition strips, the third set of partition strips are padded with sound absorbing material.

20 6. The integrated noise suppression apparatus (10) as claimed in claim 1, comprises at least four vertical pillars (200) attached with corresponding plurality of outer rings (210), wherein the plurality of outer rings (210) is integrated on an outer surface of the equipment compartment (30).

25 7. The integrated noise suppression apparatus (10) as claimed in claim 1, wherein the tubular cylinder (40) comprises a layer configured to enable the movement of the air between the tubular cylinder (40) and the equipment compartment (50).

8. A pneumatic vacuum elevator (20) comprising:

one or more vertically stacked elevator cylinders (50) configured to enable one or more users to move between a plurality of floors of a multi-storied building;

5 an integrated noise suppression apparatus (10) integrated on top of the one or more elevator cylinders (50), wherein the integrated noise suppression apparatus (10) comprises:

10 an equipment compartment (30) mounted on top of a cylinder of one or more vertically stacked elevator cylinders (50), wherein the equipment compartment comprises:

15 a first partition unit (60) vertically surrounding one or more electric motors (70) housed inside the equipment compartment (30), wherein the one or more electric motors (70) are configured to suck air from one or more vertically stacked elevator cylinders (50) and release the air into atmosphere surrounding the equipment compartment (30) to operate the pneumatic vacuum elevator (20) in upward direction;

20 a bottom plate (80) comprising a channel (85) positioned outside the first partition unit (60), wherein an pneumatic flow control unit (90) placed on top of the bottom plate (80), wherein the pneumatic flow control unit (90) is configured to allow air from the atmosphere into the corresponding one or more elevator cylinders (50) to operate the pneumatic vacuum elevator (20) in downward direction;

25 a second partition unit (100) mechanically coupled to the first partition unit (60), wherein the second partition unit (100) comprises an opening (110) in a pre-defined shape, wherein the

second partition unit (100) is configured to circulate air between the equipment compartment (30) and the atmosphere upon being sucked or released by the one or more electric motors (70) or the pneumatic flow control unit (90) respectively;

5 a silencer unit (120) placed below the one or more electric motors (70) and the pneumatic flow control unit (90) and configured to absorb noise developed during operation of the pneumatic vacuum elevator (20) upon air being circulated sequentially from the first layer (130) to the fifth layer (170).

10 9. The pneumatic vacuum elevator (20) as claimed in claim 8, wherein the silencer unit (120) comprises:

15 a first layer (130) placed upon the bottom plate (80) and above the tubular cylinder (40), wherein the first layer (130) comprises a first set of partition strips arranged in a pre-defined fashion, wherein each of the first set of partition strips comprises a corresponding plurality of square cut-outs arranged in a first pre-defined fashion, wherein the first set of partition strips is configured to initiate the circulation of air;

20 a second layer (140) placed above the first layer (130), wherein the second layer (140) comprises a second set of partition strips arranged in a pre-defined fashion, wherein each of the second set of partition strips comprises a corresponding plurality of square cut-outs arranged in a second pre-defined fashion;

25 a third layer (150) placed above the second layer, wherein the third layer (150) comprises a third set of partition strips arranged in a third pre-defined fashion, wherein each of the third set of partition strips comprises a corresponding plurality of square cut-outs arranged in a third pre-defined fashion;

a fourth layer (160) placed above the third layer (150), wherein the fourth layer (160) comprises a fourth set of partition strips arranged in a fourth pre-defined fashion, wherein each of the fourth set of partition strips comprises a corresponding plurality of square cut-outs arranged in a fourth pre-defined fashion;

a fifth layer (170) placed above the fourth layer, wherein the fifth layer (170) comprises a fifth set of partition strips (180), wherein each of the fifth set of partition strips (180) comprises a corresponding plurality of circular cut-outs arranged in a fifth pre-defined fashion, wherein the plurality of circular cut-outs are structured to position the corresponding one or more electric motors (70), wherein a plurality of layers (190) is arranged one above the other to enable the air to pass between the atmosphere and the tubular cylinder (40) via the plurality of layers (190), and

wherein an arrangement of the first set of partition strips, the second set of partition strips and the third set of partition strips forms a pre-defined structure configured to absorb noise developed during operation of the pneumatic vacuum elevator (20) upon air being circulated sequentially from the first layer (130) to the fifth layer (170).

10. The pneumatic vacuum elevator (20) as claimed in claim 8, wherein the first layer (130), the second layer (140), the third layer (150), the fourth layer (160) and the fifth layer (170) are composed of sound absorbing material.

11. The pneumatic vacuum elevator (20) as claimed in claim 8, wherein the first set of partition strips, the second set of partition strips, the third set of partition strips are composed of sound absorbing material.

25

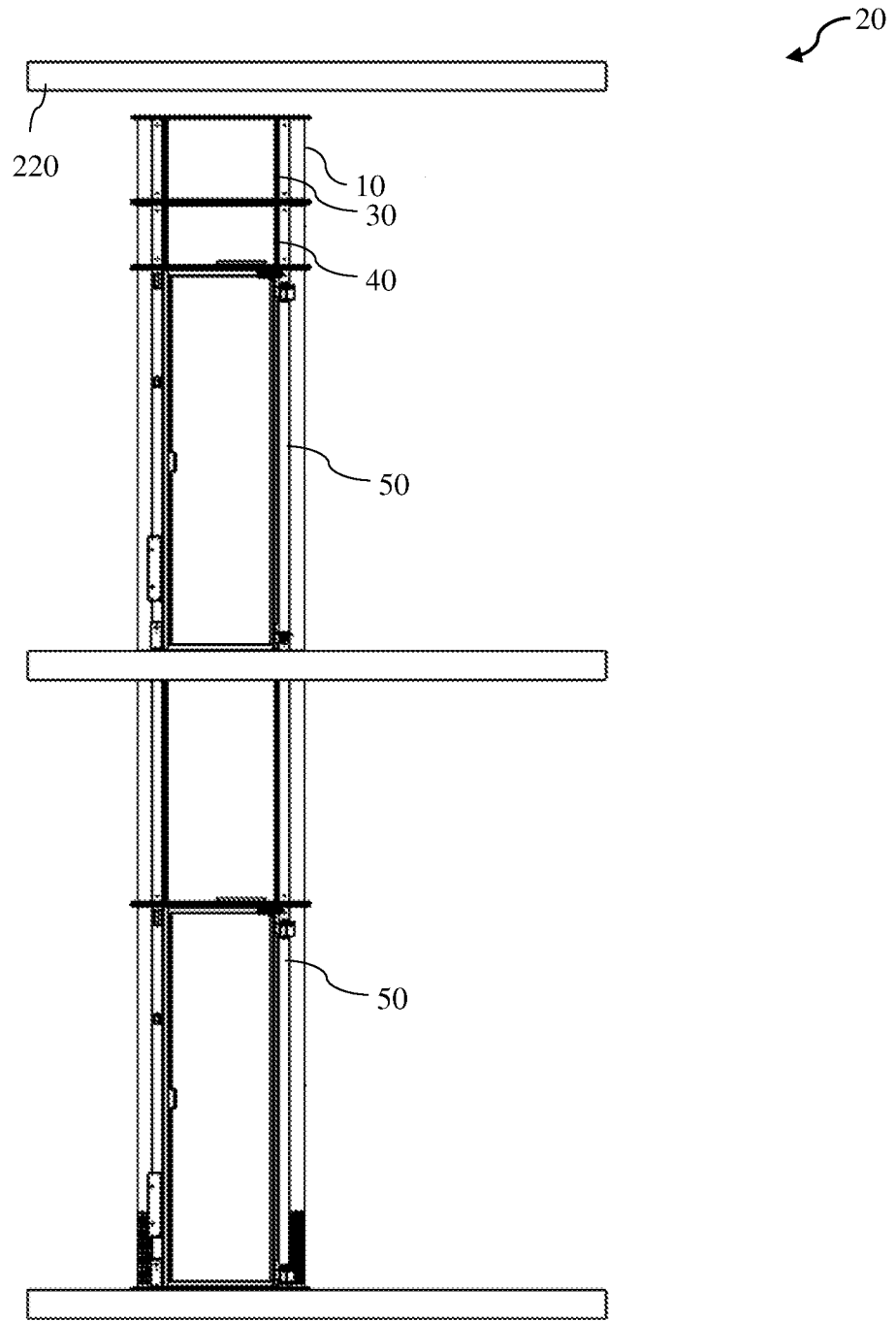

FIG. 1

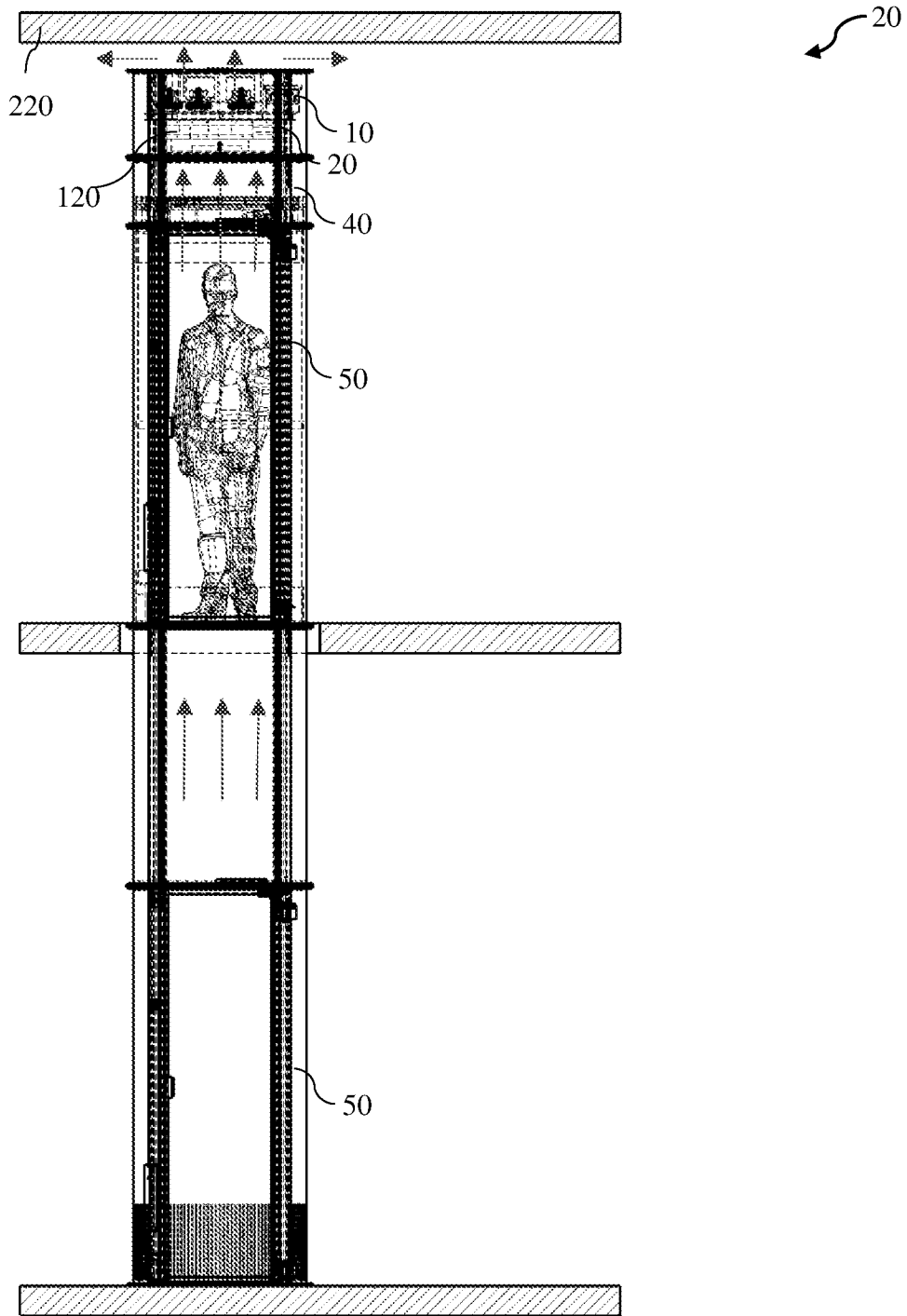

FIG. 2

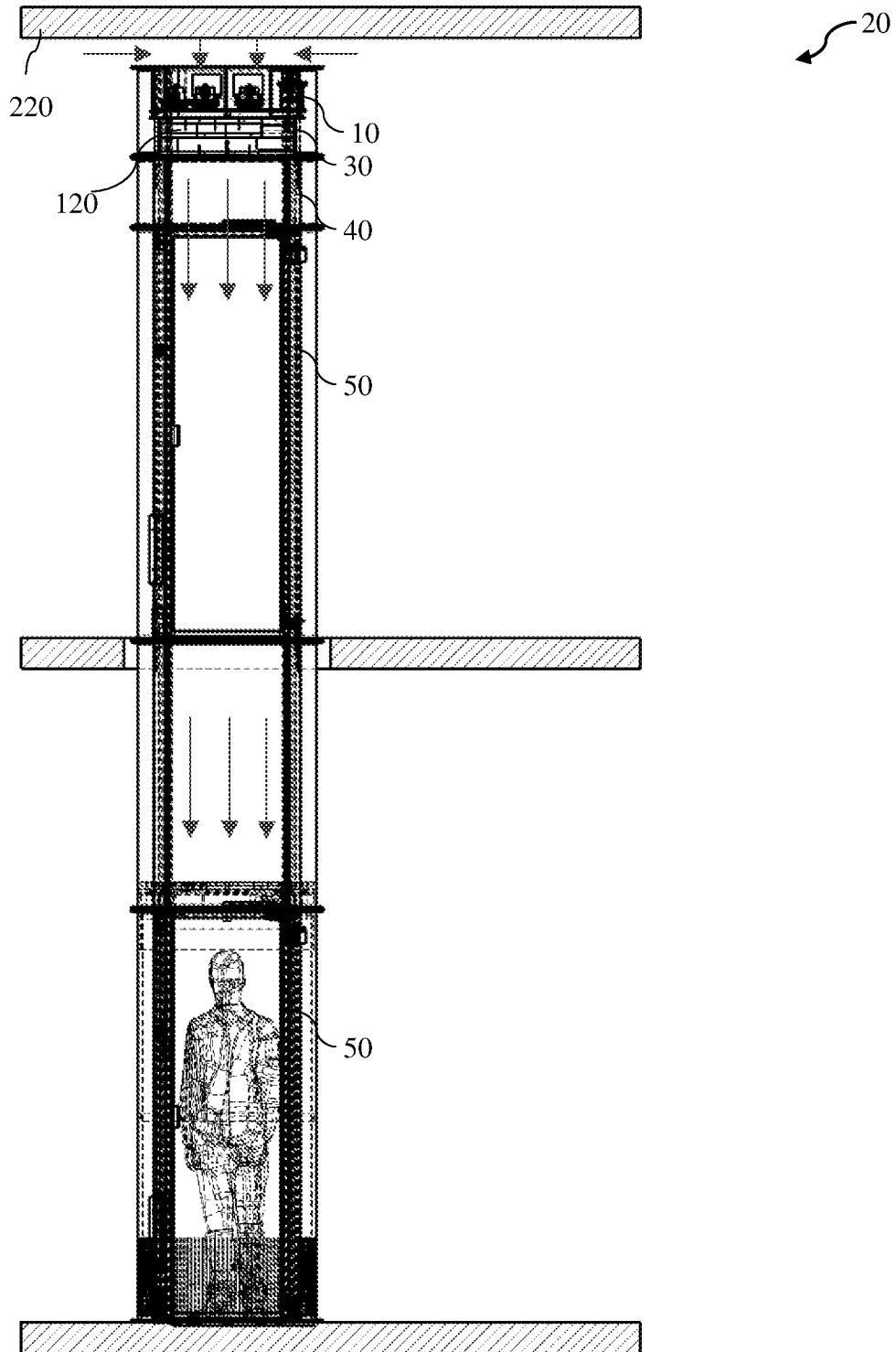

FIG. 3

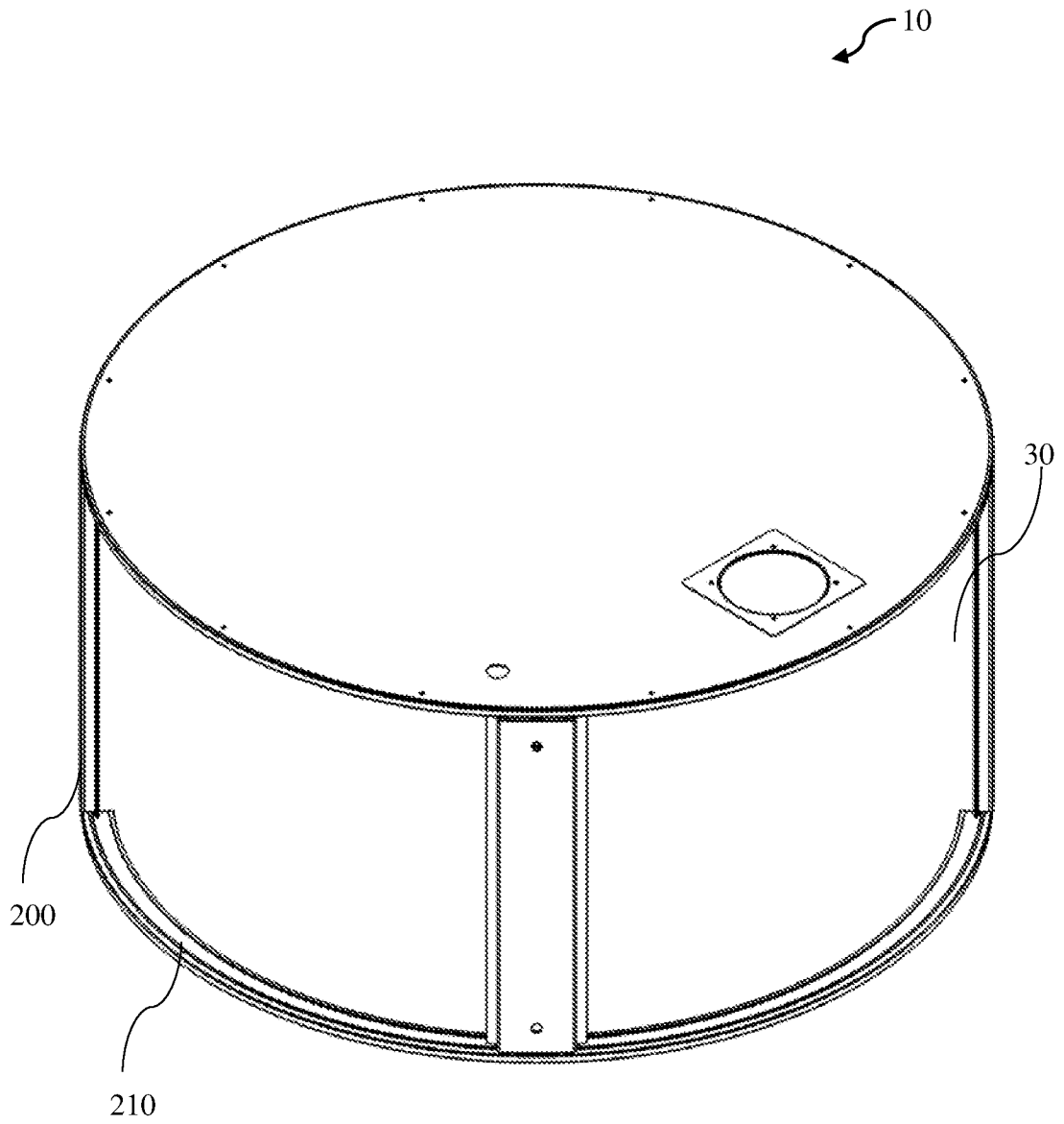

FIG. 4

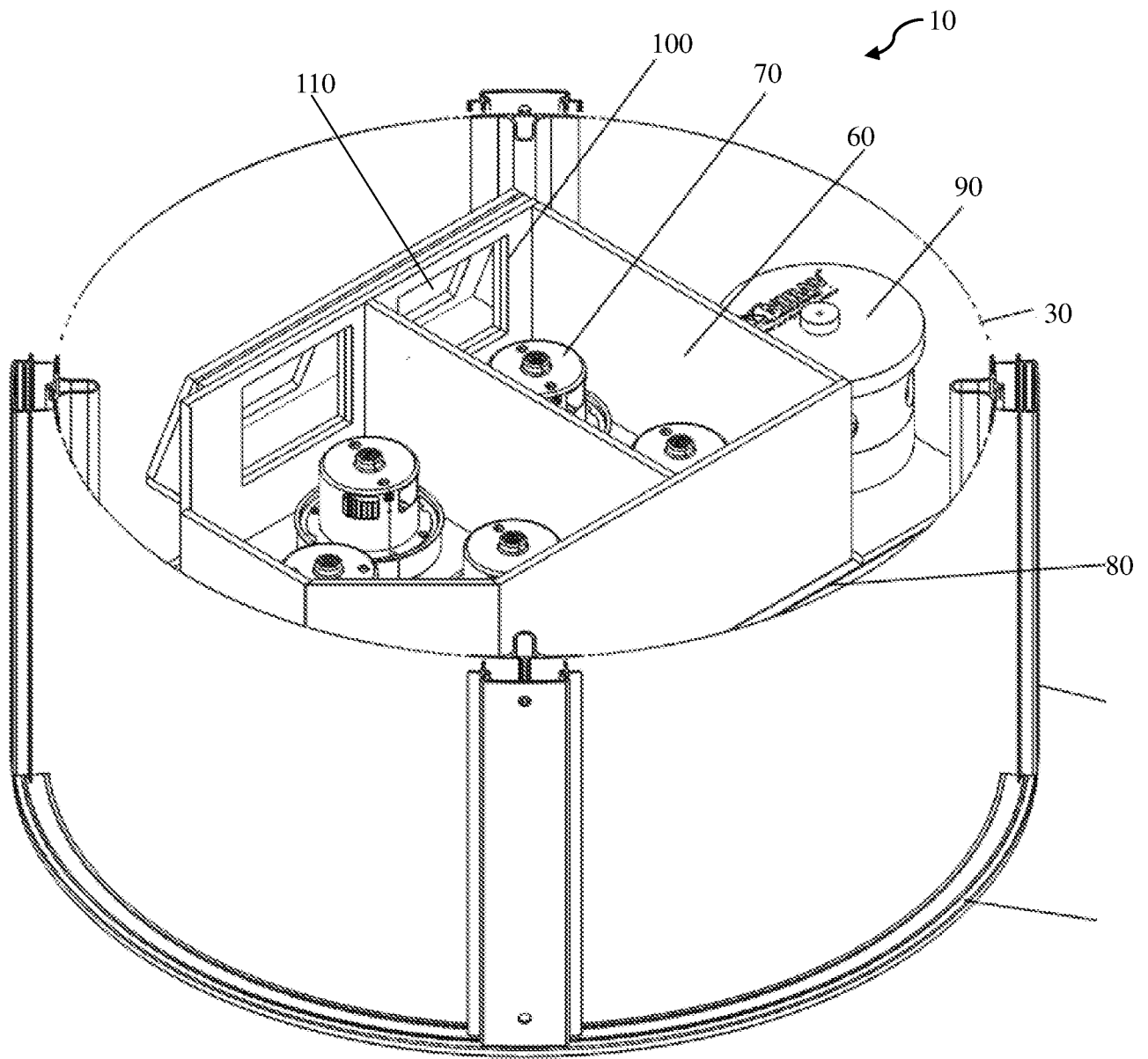

FIG. 5

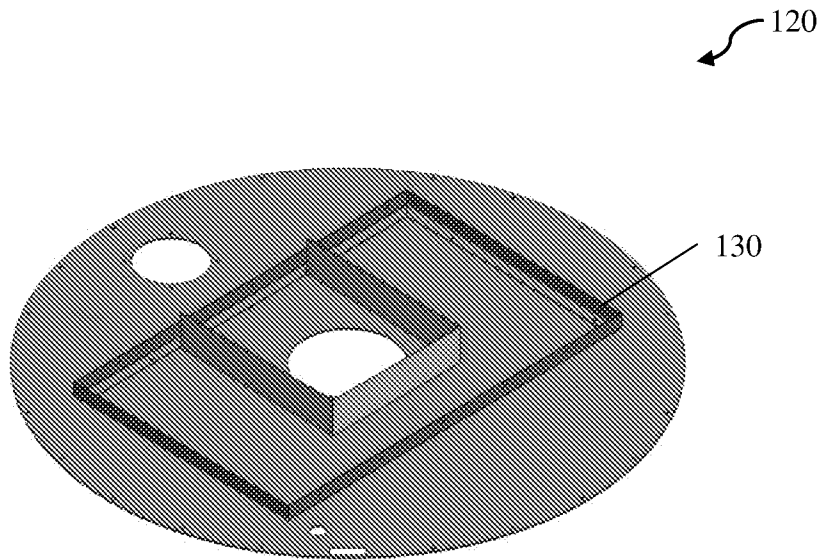

FIG. 6a

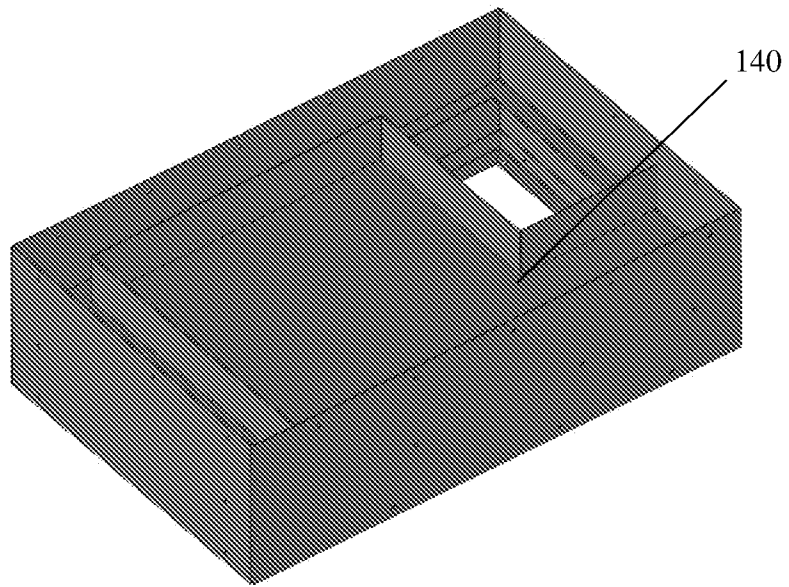

FIG. 6b

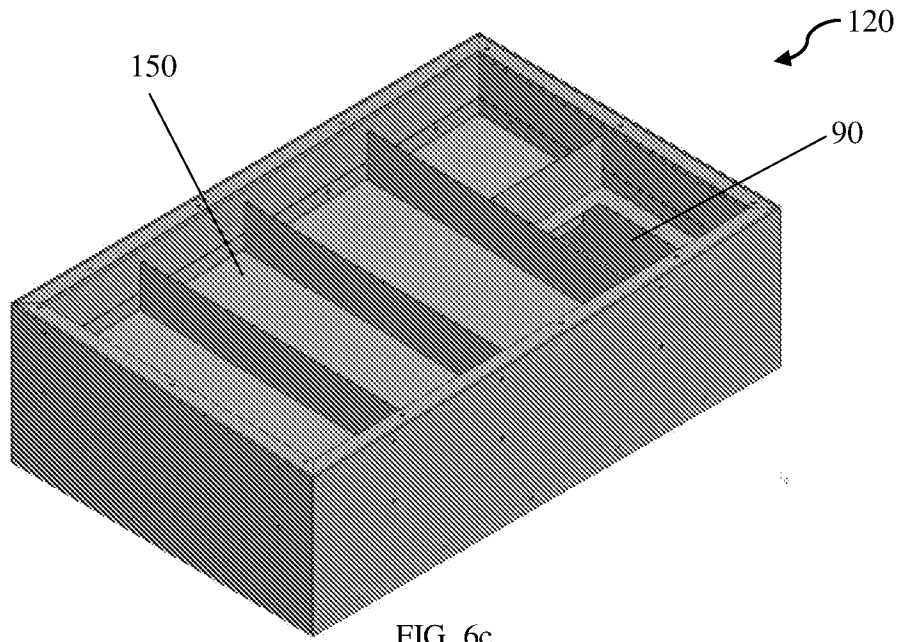

FIG. 6c

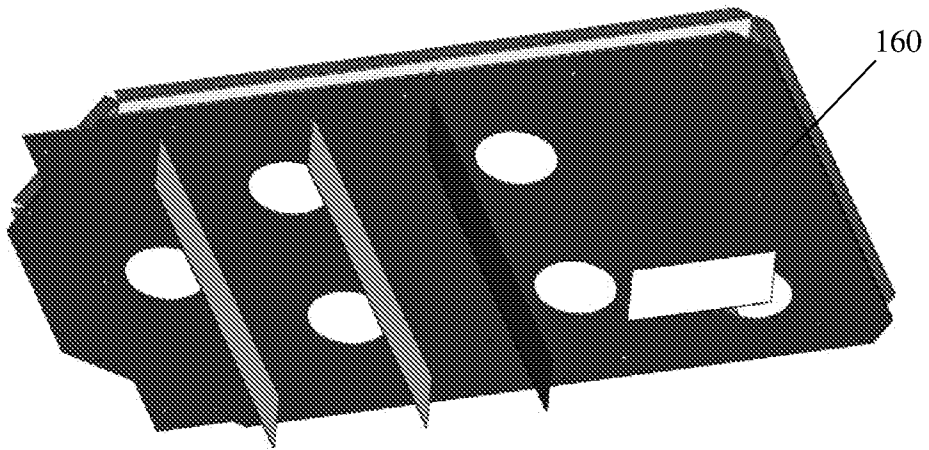
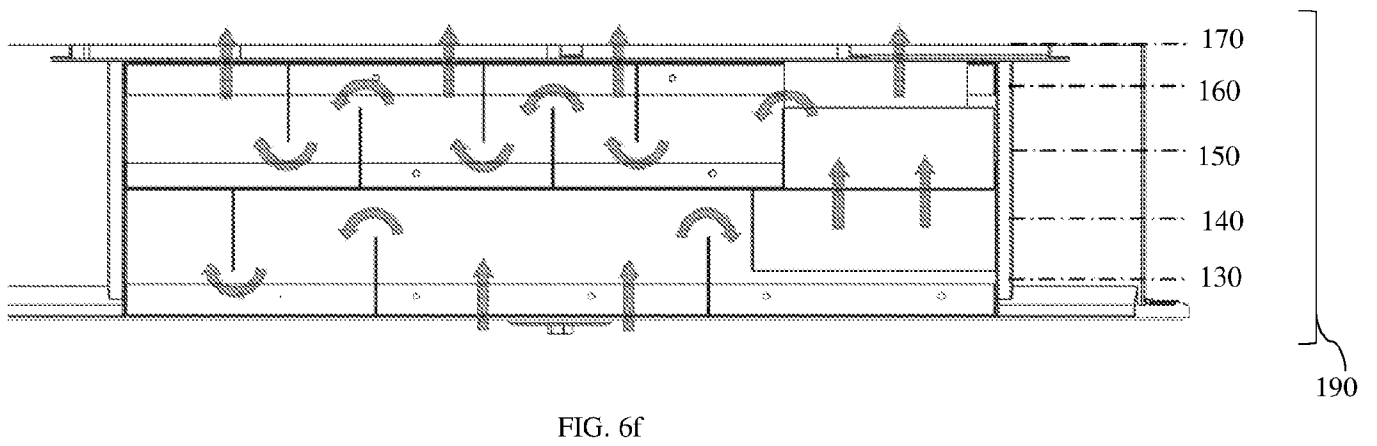
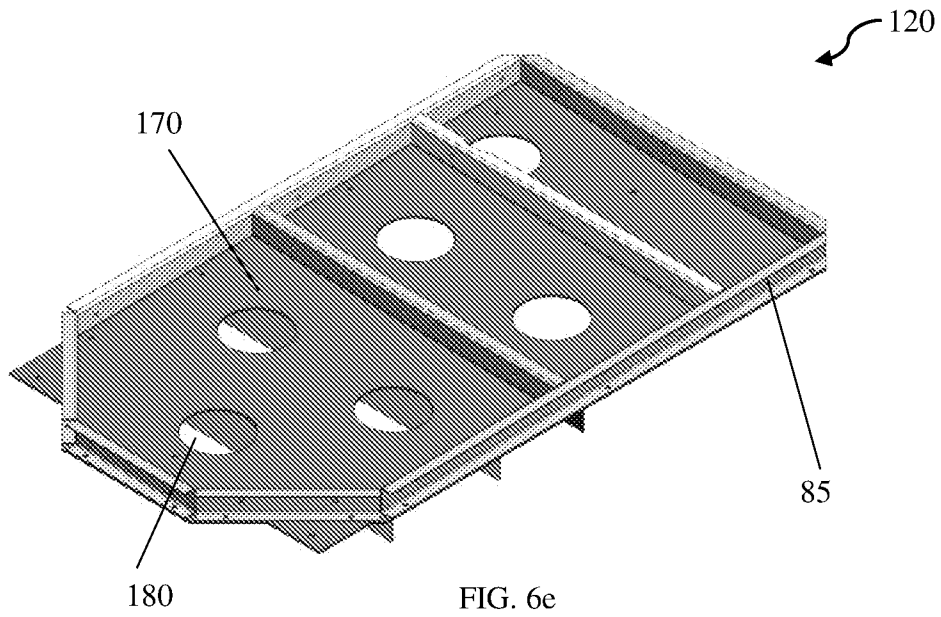

FIG. 6d



INTERNATIONAL SEARCH REPORT

International application No.
PCT/IB2021/054739

A. CLASSIFICATION OF SUBJECT MATTER
B66B9/04, B66B11/02 Version=2021.01

According to International Patent Classification (IPC) or to both national classification and IPC

B. FIELDS SEARCHED

Minimum documentation searched (classification system followed by classification symbols)

B66B

Documentation searched other than minimum documentation to the extent that such documents are included in the fields searched

Electronic data base consulted during the international search (name of data base and, where practicable, search terms used)

DATABASE: PatSeer, IPO Internal Database
KEYWORDS: PNEUMATIC, VACUUM, SOUND, ACOUSTIC, NOISE

C. DOCUMENTS CONSIDERED TO BE RELEVANT

Category*	Citation of document, with indication, where appropriate, of the relevant passages	Relevant to claim No.
Y	CN210197458U (TAIZHOU YUEYANG MARINE EQUIPMENT CO LTD) 27 MARCH 2020 (27-03-2020) English translation of PARAGRAPHS [0008-0013]; FIGURE [1 (09,10,11)]; CLAIMS [2, 3, 4, 5] from Espacenet.	1-11
Y	CN205892443U (GFC CO LTD) 18 JANUARY 2017 (18-01-2017) English translation of ABSTRACT; PARAGRAPHS [0042-0045]; FIGURE [4 (12, 16, 20, 40, 202)] from Espacenet.	1-11

Further documents are listed in the continuation of Box C.

See patent family annex.

* Special categories of cited documents:

"A" document defining the general state of the art which is not considered to be of particular relevance

"D" document cited by the applicant in the international application

"E" earlier application or patent but published on or after the international filing date

"L" document which may throw doubts on priority claim(s) or which is cited to establish the publication date of another citation or other special reason (as specified)

"O" document referring to an oral disclosure, use, exhibition or other means

"P" document published prior to the international filing date but later than the priority date claimed

"T" later document published after the international filing date or priority date and not in conflict with the application but cited to understand the principle or theory underlying the invention

"X" document of particular relevance; the claimed invention cannot be considered novel or cannot be considered to involve an inventive step when the document is taken alone

"Y" document of particular relevance; the claimed invention cannot be considered to involve an inventive step when the document is combined with one or more other such documents, such combination being obvious to a person skilled in the art

"&" document member of the same patent family

Date of the actual completion of the international search

27-08-2021

Date of mailing of the international search report

27-08-2021

Name and mailing address of the ISA/

Indian Patent Office
Plot No.32, Sector 14, Dwarka, New Delhi-110075
Facsimile No.

Authorized officer

Arpit Singh Thakur

Telephone No. +91-1125300200