

No. 30,456.

PATENTED OCT. 23, 1860.

H. BARTH.
PRINTING PRESS FEEDER.

Fig. 1.

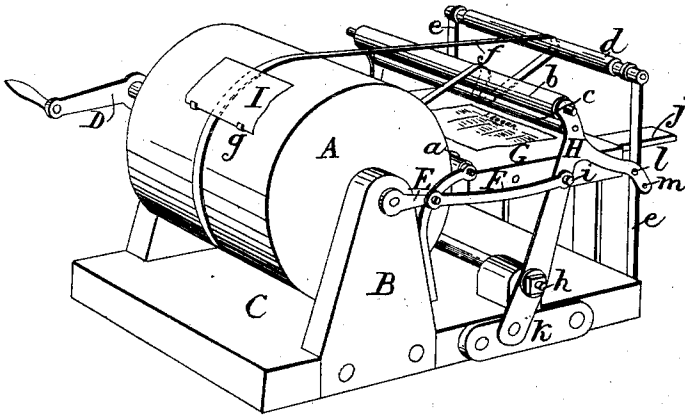
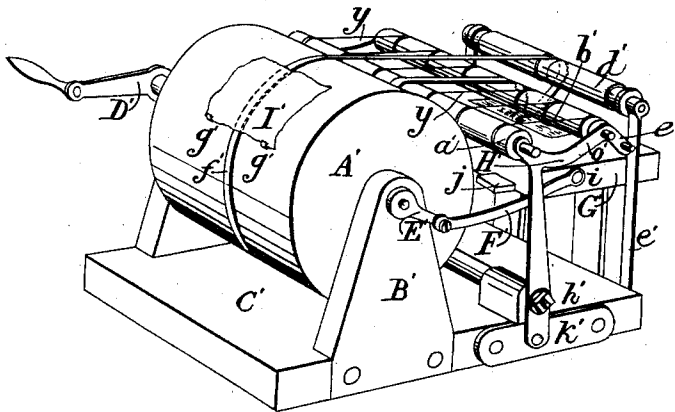

Fig. 2.



Witnesses:

Wm. O. Knight
Geo. Robinson

Inventor:

Henry Barth

UNITED STATES PATENT OFFICE.

HENRY BARTH, OF CINCINNATI, OHIO.

PRINTING-PRESS FEEDER.

Specification of Letters Patent No. 30,456, dated October 23, 1860.

To all whom it may concern:

Be it known that I, HENRY BARTH, of Cincinnati, in the county of Hamilton and State of Ohio, have invented an Improved Device for Feeding Off Paper from Printing-Presses; and I do hereby declare that the following is a full, clear, and exact description thereof, reference being had to the accompanying drawings and to the letters of reference marked thereon.

My invention consists in the device for feeding off the paper from a printing press, after it is printed, by means of tape rollers which are made to reciprocate over a stationary receiving table, depositing the paper thereon, or by a reciprocating table in combination with stationary tape rollers, the table traversing beneath the rollers and receiving the paper therefrom, the effect produced and the means employed being essentially the same in both devices.

In the annexed drawings Figure 1 is a perspective view of the device representing the adjustment of parts for "feeding off" by means of the reciprocating tape rollers and stationary table, and Fig. 2, is a perspective view of the apparatus adjusted to "feed off" by means of stationary tape rollers and reciprocating table.

Like letters of reference are employed to designate corresponding parts in the two figures, the letters which are employed in Fig. 2, being designated from the same letters in Fig. 1, by the mark for primes (').

A, A', is the pressure cylinder by which the paper to be printed is pressed against the form of a printing press, and thereby printed. It is represented as supported by uprights B, B', which are carried by the base C, C'. The cylinders are rotated by the crank D, D'.

E, E', is a crank secured to the cylinder shaft having a pitman F, F', by which it may be connected with and communicate motion to either the table G, G', or the roller frame H, H'.

a, a' is a stationary roller. In Fig. 1, this roller is carried by arms *w*, which are secured to the uprights B one at either end of the cylinder A. In Fig. 2, the same roller is carried by the frame H, which in this arrangement of the apparatus is stationary.

b, b', and c, c' are tape rollers carried by the frame H, H'.

d, d', is an auxiliary tape roller supported

by the uprights e, e', which are elastic, serving by a yielding force to preserve the tension of the tapes, at the same time that the tapes are not held rigidly and rendered liable to be stretched or broken.

f, f', represents the tapes which are endless, encircling the cylinder A, and passing around or over the tape rollers a, a', b, b', c, c', d, d', as represented in the drawings uniting at the point of beginning. These tapes convey the paper from the cylinder to the receiving table as will be shown.

In Fig. 2, there are represented a series of endless cords *g*, surrounding rollers a', b'. These prevent the paper as it is conveyed from the cylinder A', by the tapes from falling through the space between the rollers a', b'.

In the arrangement of the parts represented in Fig. 1, the pitman F, is secured to the frame H, at *i* and the rotation of the crank E, causes the frame to vibrate simultaneously therewith around the point *h*, where the frame is pivoted.

In Fig. 2, the pitman F', is represented as secured at *i'* to the receiving table G'. The table is supported by horizontal bars *j*, *j'*, upon which it is free to slide or be reciprocated by the action of the crank E and pitman F.

In the operation of the apparatus for "feeding off," the sheet of paper to be printed I, I', is placed upon the cylinder A, A', with the margin of the paper inserted under the small shelving stops *g*, *g'*, by which it is held while the cylinder revolves and conveys the paper and impresses it against the form of type upon the printing press which is supposed to be in connection with the cylinder A, A'. The paper is thence conveyed around upon the cylinder until it passes up between the cylinder A, A' and the tape rollers a, a'.

Referring now exclusively to Fig. 1, the paper after passing up between the cylinder A, and the roller a, is caught under the tape *f*, and passes over roller b, and down between it and roller c, when it escapes from the tape rollers down upon the receiving table G. At the same time that the sheet of paper escapes from the tape rollers b, c, the frame H carrying the rollers b and c, is caused by the rotation of crank E with which it is in connection by pitman F, to vibrate away from the cylinder A carrying

the rollers *b*, *c*, and as it traverses above the table *G*, deposits the sheet with the printed side up evenly and smoothly thereon.

In Fig. 2, the printed sheet of paper after passing up between the cylinder *A'* and the tape roller *a'*, as has been described, is caused by the tape to pass over the tape roller *a'* and along on the cords *y*, away from the cylinder *A'*, and down between the rollers *b'*, *c'*, and out from between these rollers toward the receiving table *G'*, but as the paper approaches the table the crank *E'*, acting through the pitman *F'*, causes the table to be drawn toward the roller *A'*, the effect of which is to cause the sheet of paper as it escapes from the tape rollers *b'* *c'* to deposit itself smoothly and evenly upon the receiving table *G'*, and the paper by this arrangement of the parts for "feeding out" will be deposited with the printed side up as by the arrangement previously described.

Should it be required to change the device as represented in Fig. 1, to operate as in Fig. 2, the pitman *F*, which in Fig. 1, vibrates the frame *H*, by the pin *i* may be detached therefrom and secured by the same pin to the table *G*, as in Fig. 2, at the same time the frame *H*, is placed in an upright position and rendered stationary by an auxiliary pin inserted through the hole *h*, (*h'*) in the lower end of the upright part of the frame *H* (*H'*) into the base *C*, (*C'*). The rollers *a* and *c* are then removed from their respective positions and their end journals introduced appropriately into bearings *l*, and *m*, in the end of the projecting arm *o*, of the frame *H*. The tape and cords then being appropriately applied to the tape rollers as in Fig. 2, the whole apparatus is changed to correspond with and to operate precisely as has been described with reference to the operation of Fig. 2.

It is obvious that the tape rollers which are herein described as conveyed by a vibrating frame as in Fig. 1, could be arranged with equal facility to be carried by a frame having a rectilinear reciprocating motion. It will also be apparent that for the purpose of causing the tape rollers to traverse over the table at a uniform rate corresponding with the rate at which the paper escapes from the rollers so that the latter will be deposited fairly upon the table, it might be re-

quired to impart motion to the frame *H*, which carries the rollers, or to the receiving table, provided that is arranged to move in place of the frame carrying the rollers by some convenient means which will impart a uniform reciprocating motion thereto in place of a varying motion as produced by the crank. These variations in the general construction of the apparatus for "feeding out" will not be required in presses for printing small sheets but in presses for printing large sheets when the paper would be liable to gather into folds without falling out fair and level, the variations in the construction above described which provide against occurrences of this kind may be introduced.

I do not claim as my invention the use of the feed rollers and tapes or the receiving table, or the combination of any or all of these for the purpose described as their use in various combinations has been known for many years (see Hansard's *Typography*, London, 1825); but I am not aware that tape rollers carried over the receiving table for the purpose of depositing the printed sheet evenly thereon, or the receiving table traversing under the tape rollers for the purpose of receiving the printed sheet as its escape therefrom was ever before known or used.

Therefore what I claim as new and desire to secure by Letters Patent, is—

1. "Feeding out" the paper from a printing press by means of the tape rollers *a*, *b*, *c*, *d*, frame *H*, receiving table *G*, and tapes *f*, when combined, arranged and operating substantially in the manner herein described, that is when the rollers *b*, *c*, are caused to traverse above the stationary table *G*, depositing the printed sheet thereon, or when the table *G*, is caused to reciprocate under the stationary tape rollers *b*, *c*, for the purpose of receiving the printed sheet therefrom in the manner essentially as described.
2. The elastic supports *e* *e'* carrying the auxiliary tape rollers *d* *d'* when used in combination with the reciprocating tape rollers *a* *a'* *b* *b'* or the reciprocating table *G* *G'* substantially as described.

HENRY BARTH.

Witnesses:

WM. CLOUGH,
JNO. Q. ADAMS.