

(19) World Intellectual Property
Organization
International Bureau



(43) International Publication Date
24 June 2004 (24.06.2004)

PCT

(10) International Publication Number
WO 2004/053375 A2

(51) International Patent Classification⁷: **F16L**

(21) International Application Number:
PCT/US2003/038524

(22) International Filing Date: 4 December 2003 (04.12.2003)

(25) Filing Language: English

(26) Publication Language: English

(30) Priority Data:
10/313,298 6 December 2002 (06.12.2002) US

(71) Applicant: **PLASTIC TRENDS, INC.** [US/US]; 56400
Mound Road, Shelby Township, MI 48316 (US).

(72) Inventor: **HOUGHTON, Jon**; 1725 Washington Road,
Rochester Hills, MI 48306 (US).

(74) Agent: **KELLY, Robert, L.**; Dykema Gossett PLLC,
39577 Woodward Avenue, Suite 300, Bloomfield Hills,
MI 48304 (US).

(81) Designated States (*national*): AE, AG, AL, AM, AT, AU, AZ, BA, BB, BG, BR, BY, BZ, CA, CH, CN, CO, CR, CU, CZ, DE, DK, DM, DZ, EC, EE, ES, FI, GB, GD, GE, GH, GM, HR, HU, ID, IL, IN, IS, JP, KE, KG, KP, KR, KZ, LC, LK, LR, LS, LT, LU, LV, MA, MD, MG, MK, MN, MW, MX, MZ, NI, NO, NZ, OM, PG, PH, PL, PT, RO, RU, SC, SD, SE, SG, SK, SL, SY, TJ, TM, TN, TR, TT, TZ, UA, UG, UZ, VC, VN, YU, ZA, ZM, ZW.

(84) Designated States (*regional*): ARIPO patent (BW, GH, GM, KE, LS, MW, MZ, SD, SL, SZ, TZ, UG, ZM, ZW), Eurasian patent (AM, AZ, BY, KG, KZ, MD, RU, TJ, TM), European patent (AT, BE, BG, CH, CY, CZ, DE, DK, EE, ES, FI, FR, GB, GR, HU, IE, IT, LU, MC, NL, PT, RO, SE, SI, SK, TR), OAPI patent (BF, BJ, CF, CG, CI, CM, GA, GN, GQ, GW, ML, MR, NE, SN, TD, TG).

Published:

— *without international search report and to be republished upon receipt of that report*

For two-letter codes and other abbreviations, refer to the "Guidance Notes on Codes and Abbreviations" appearing at the beginning of each regular issue of the PCT Gazette.



WO 2004/053375 A2

(54) Title: PIPE FITTING WITH COMPOSITE GASKET ASSEMBLY

(57) Abstract: A pipe fitting includes a body having sockets for receiving pipes therein and a composite gasket housed within a circumferential gasket retention housing integral with the socket. The composite gaskets include a V-shaped carrier of relatively stiff plastic having an elastomeric seal portion bonded thereto.

PIPE FITTING WITH COMPOSITE GASKET ASSEMBLY

BACKGROUND OF THE INVENTION

Field of the Invention

The present invention relates to a pipe fitting and gasket assembly for conducting fluid flow.

Disclosure Information

Fluid conducting pipes have been available with slip fittings for a number of years. Some fittings with slip fits use an external nut to tighten a packing on the inserted pipe. This mechanism, however, requires labor and additional parts and may be awkward to install, particularly in below ground or otherwise confined spaces. Other types of slip fittings, particularly those used in applications such as drain or sewer pipes, have used slip fittings without the need for tightening a nut. For example, FIG. 2 illustrates a prior art seal in which plastic band 202 is combined with a very large elastomeric part 200. Unfortunately, the gasket or seal of FIG. 2 is quite expensive due to the need to provide this large elastomeric body.

SUMMARY OF THE INVENTION

A pipe fitting for telescopically receiving at least one pipe includes a body having a generally cylindrical wall defining an opening for receiving a pipe. A circumferential gasket retention region projects radially outwardly from a portion of the generally cylindrical wall, so as to define an annular gasket retention race or channel. A gasket having a generally V-shaped cross-section is provided within the gasket retention channel and includes a V-shaped carrier portion of relatively stiff plastic and an elastomeric seal-forming portion. The gasket is adapted to be radially and elastically compressed by a pipe inserted axially into the fitting body. In a preferred embodiment, the V-shaped carrier portion and elastomeric sealing portion may be co-molded, with the elastomeric portion being formed from a resilient material and the V-shape carrier being formed from a relatively stiffer material. In this manner, the inventive gasket seal may be easily and economically produced by co-molding.

The gasket of the present invention has an outer leg adapted to abut the floor of the gasket retention channel. The gasket further has an inner leg hinged to the outer leg with the inner leg being adapted to abut a pipe inserted into a fitting into which the gasket has been seated.

The elastomeric seal portion of the inner leg of the gasket preferably includes an annular sealing flap or ring extending radially inwardly from the gasket body such that a pipe inserted telescopically into the fitting compresses the annular sealing ring while simultaneously elastically deforming the V-shaped carrier.

It is an advantage of the present invention that a pipe fitting and gasket assembly according to this invention produces superior results in terms of performance under vacuum and resistance to pressure conditions.

It is a further advantage of the present system that leak tight sealing is provided without the need for the use of special tools for assembling various pipe fittings.

Other advantages, as well as objects and features of the present invention, will become apparent to the reader of this specification.

BRIEF DESCRIPTION OF THE DRAWINGS

FIG. 1 is a perspective view of a pipe fitting having a sealing system according to present invention.

FIG. 2 illustrates a prior art gasket assembly.

FIG. 3 illustrates a gasket assembly according to one aspect of the present invention.

FIG. 4 illustrates a pipe fitting and joint assembly according to one aspect of the present invention.

DETAILED DESCRIPTION OF THE PREFERRED EMBODIMENTS

As shown in FIG. 1, pipe fitting 10 (typically formed of PVC) has generally cylindrical wall 12 with a plurality of generally cylindrical sockets or openings 14 for

receiving pipes (such as pipe 52 in FIG. 4) inserted into fitting 10. Gasket 18 is used for sealing pipe 52 in fitting 10. Gasket 18 is inserted into and retained by a gasket retention portion 16. As shown with more specificity in FIG. 4, gasket retention portion 16 defines an annular gasket retention channel 17 into which a gasket 18 maybe snapped so as to retain gasket 18 both axially and radially.

The details of gasket 18 in the preferred embodiment are shown in FIG. 3. Gasket 18 is preferably a composite of two types of molded materials, but may be a single type of material fabricated to provide two different hardnesses. V-shaped carrier portion 20 serves essentially as a spring element for gasket 18 and preferably comprises polyethylene. Those skilled in the art will appreciate in view of this disclosure that the material for V-shaped carrier portion 20 may be selected from a variety of other known materials such as polypropylene, polystyrene, ABS or other plastics. It will be understood from the present disclosure that the material from which V-shaped carrier portion 20 is formed should be stiff, yet must flex at hinge portion 26 (best seen in FIG. 3) repeatedly without cracking or breaking. In other words, V-shaped carrier portion 20 biases inner leg 24 against pipe 52 as will be explained more fully hereinafter. Most preferably, V-shaped carrier portion 20 should have a hardness (Shore D durometer) of between about 40 to 50.

V-shaped carrier portion 20 includes outer leg 22 which biases gasket 18 against the outer circumference or floor of the annular gasket retention channel 17 defined by gasket retention housing 16; inner leg 24 biases against pipe 52 inserted into fitting 10. As stated, V-shaped carrier portion 20 has a hinge portion 26 which allows the V to flex. Referring to FIG. 4, pipe 52 is telescopically inserted into fitting 10. In turn, gasket 18 is radially compressed by pipe 52 when pipe 52 is inserted into fitting 10. In other words, the V-shaped nature of gasket 18 along with the stiffness of carrier portion 20 creates a spring biasing effect. V-shaped carrier 20 preferably also has a plurality of annular bump stops 28 which help prevent carrier portion 20 from collapsing or deforming more than a predetermined amount under radially directed stress imposed by pipe 52 inserted in the fitting 10. Additional annular beads, such as bead 53 of FIG. 3 may be provided to further control the biasing force of gasket 18.

Elastomeric seal portion 32 comprises an integral part of gasket 18. Elastomeric seal portion 32 may be made of a number of elastomeric materials known to those skilled

in the art such as polyethylene, polypropylene, natural or synthetic rubber, neoprene, nitriles, polyvinyl and various other resilient materials. It will be recognized from the present disclosure that the material used to form elastomeric seal portion 32 is preferably an elastomer or elastomerized material, most preferably having a hardness (Shore A durometer) of from about 45 to about 65 and a more preferably from about 50 to about 60. Elastomeric seal portion 32 has an outer portion 34 which bears against the floor of gasket retention housing portion 16. Elastomeric seal 32 also has an inner portion 36, which in this embodiment (with the remainder of elastomeric seal 32), is bonded to V-shaped carrier 20. Co-molding or co-extrusion of carrier 20 with elastomeric seal portion 32 is expected to comprise an economical process for manufacturing gasket 18. It should be noted that the amount of elastomeric material needed to fabricate a gasket according to the present invention is much less than that required for the prior art gasket illustrated in FIG. 2 due to the "V" cutout. As a result, the cost savings offered by the inventor's gasket may be considerable. As stated, alternatively, carrier 20 and sealing portion 32 may be made of the same type of material, so long as carrier 20 is stiffer than sealing portion 32.

Elastomeric seal portion 32 includes an annular sealing ring or projection 38 which extends radially inwardly from inner portion 36 of elastomeric seal 32, such that a pipe inserted telescopically into fitting 10 compresses and deflects annular sealing ring 38 while simultaneously elastically deforming V-shaped carrier 20 as best shown in FIG. 4.

In order to assure that debris which may be adhering to the outside of pipe 52 does not interfere with annular sealing ring 38, elastomeric seal 32 is further equipped with scraper ring or wiper 40 which extends radially inwardly from inner portion 36 of seal 32, so as to physically remove deposits such as dirt or small rocks from the surface of a pipe as it is inserted into fitting 10. This assures an excellent seal between the outer wall of the pipe being inserted and elastomeric seal 32. Alternatively, the scraper ring may be formed on V-shaped carrier 20. Under vacuum conditions, wiper 40 also helps provide a tight seal.

Although the present invention has been described in connection with particular embodiments thereof, it is to be understood that various modifications, alterations and adaptations may be made by those skilled in the art without departing from the spirit and scope of the invention. It is intended that the invention be limited only by the appended claims.

WHAT IS CLAIMED:

1. A pipe fitting for telescopically receiving at least one pipe, said fitting comprising:
 - a body having a generally cylindrical wall defining an opening for receiving a pipe;
 - said body further defining an annular gasket retention space; and
 - a gasket housed within said annular gasket retention space, said gasket having a v-shaped portion and a sealing portion, said v-shaped portion being formed of a stiffer material than said sealing portion.
2. A pipe fitting according to Claim 1, wherein said gasket is adapted to be radially compressed by a pipe inserted axially into said opening for receiving a pipe.
3. A pipe fitting according to Claim 1, wherein said gasket is adapted to be elastically and radially compressed by a pipe inserted axially into said fitting.
4. A pipe fitting according to Claim 1, wherein said v-shaped carrier and said elastomeric seal are co-molded.
5. A pipe fitting according to Claim 1, wherein said v-shaped carrier is adapted to be elastically deformed by a pipe inserted telescopically into said fitting.
6. A pipe fitting according to Claim 1, wherein said sealing portion includes an annular sealing ring extending radially inwardly from said v-shaped carrier.
7. A pipe fitting according to Claim 1, wherein said elastomeric seal comprises an annular sealing ring extending radially inwardly from an inner leg of said v-shaped carrier such that a pipe inserted telescopically into the fitting compresses said annular sealing ring, while simultaneously elastically deforming said v-shaped carrier.
8. A pipe fitting according to Claim 1, wherein said gasket is adapted to seal against a flow of sewage through said pipe fitting.

9. A pipe fitting according to Claim 1, wherein said v-shaped carrier is formed from low density polyethylene.

10. A pipe fitting according to Claim 1, wherein said elastomeric seal is formed from neoprene.

11. A pipe fitting according to Claim 1, wherein said elastomeric seal is formed from ethylene propylene rubber.

12. A pipe fitting according to Claim 1, wherein said sealing portion further comprises a scraper ring integral with and extending radially inwardly from an inner leg of said v-shaped carrier, such that a portion of the outside surface of a pipe inserted into said fitting will be scraped as the pipe is inserted.

13. A pipe fitting according to Claim 1, wherein said body is molded of plastic.

14. A pipe fitting according to Claim 1, wherein said body is molded of polyvinylchloride.

15. A composite gasket for sealing a pipe inserted into a pipe fitting, said gasket comprising:

a relatively stiff unitary plastic carrier having an outer leg adapted to abut an inner circular wall of a pipe fitting, and an inner leg hinged to the outer leg, said inner leg being adapted to abut a pipe inserted into a fitting into which said plastic carrier has been seated; and

an elastomeric seal bonded to at least said inner leg, with said seal being adapted for sealing contact with a pipe inserted into a fitting into which said gasket has been mounted.

16. An annular gasket, comprising:

a V-shaped carrier portion;

a resilient body bonded to at least part of said V-shaped carrier portion, said V-shaped carrier portion being stiffer than said resilient body; and

said resilient body having an annular wiper portion.

17. The annular gasket recited in claim 16, wherein said V-shaped carrier portion is formed of a polymer selected from the group consisting of polyethylene, polypropylene, polystyrene, ABS and combinations thereof and said resilient body is formed of a polymer selected from the group consisting of polyethylene, polypropylene, neoprene, rubber, nitriles, polyvinyl and combinations thereof.

18. The annular gasket recited in claim 16, wherein said V-shaped carrier portion has a hardness of from 40 to 50 Shore D durometer and said resilient body has a hardness of from about 45 to about 65 Shore A durometer.

1/2

Fig. 1

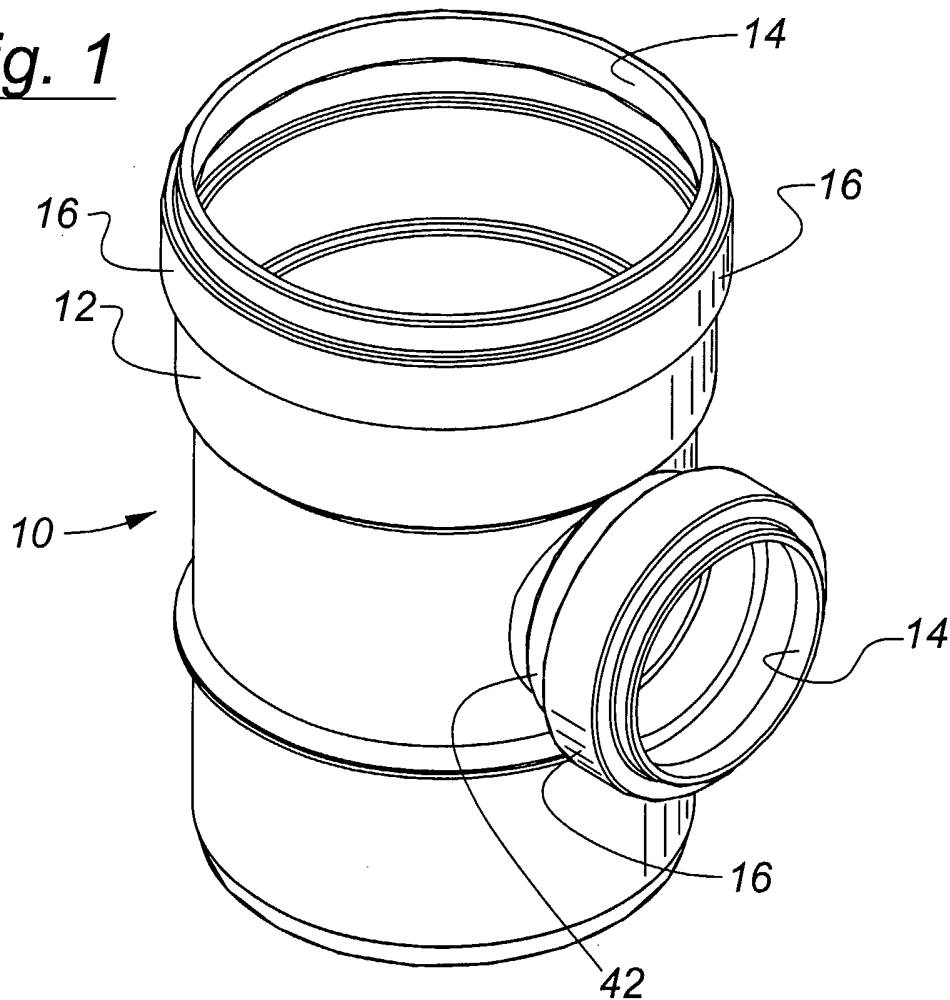

Fig. 2

Prior Art

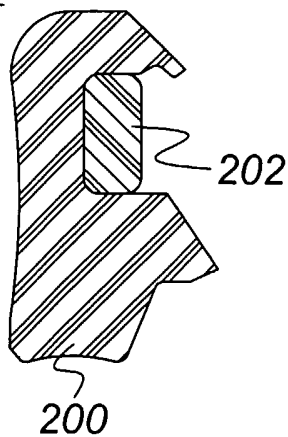

Fig. 3

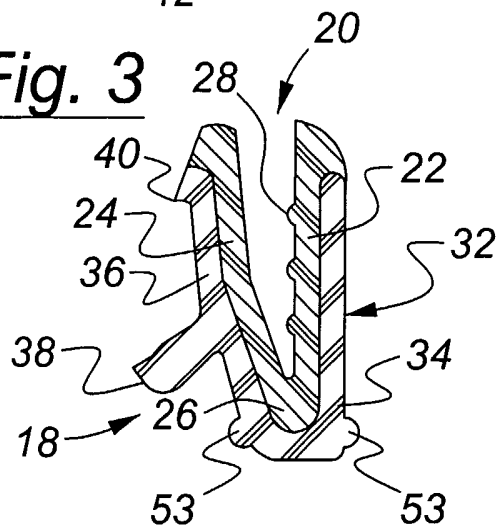

Fig. 4

