

(19) **DANMARK**

(10) **DK/EP 3982131 T3**



(12) **Oversættelse af
europæisk patentskrift**

Patent- og
Varemærkestyrelsen

-
- (51) Int.Cl.: **G 01 R 31/08 (2020.01)** **G 01 R 19/25 (2006.01)** **H 02 J 13/00 (2006.01)**
H 04 B 3/46 (2015.01)
- (45) Oversættelsen bekendtgjort den: **2024-12-16**
- (80) Dato for Den Europæiske Patentmyndigheds bekendtgørelse om meddelelse af patentet: **2024-09-11**
- (86) Europæisk ansøgning nr.: **21201657.0**
- (86) Europæisk indleveringsdag: **2021-10-08**
- (87) Den europæiske ansøgnings publiceringsdag: **2022-04-13**
- (30) Prioritet: **2020-10-08 EP 20200834**
- (84) Designerede stater: **AL AT BE BG CH CY CZ DE DK EE ES FI FR GB GR HR HU IE IS IT LI LT LU LV MC MK MT NL NO PL PT RO RS SE SI SK SM TR**
- (73) Patenthaver: **Helmut-Schmidt-Universität, Holstenhofweg 85, 22043 Hamburg, Tyskland**
- (72) Opfinder: **SCHULZ, Detlef, , 22043 Hamburg, Tyskland**
- (74) Fuldmægtig i Danmark: **AWA Denmark A/S, Strandgade 56, 1401 København K, Danmark**
- (54) Benævnelse: **SYSTEM TIL KOMBINERET STED-, TIDS- OG FREKVENSAFHÆNGIG BESTEMMELSE AF ELEKTRISKE PARAMETRE I ET STRØMFORSYNINGSNETVÆRK**
- (56) Fremdragne publikationer:
EP-A1- 3 336 995
EP-A1- 3 540 911
WO-A1-2008/019634
WO-A1-2015/168260
WO-A2-2016/174476
AU-B1- 2019 284 127
CN-A- 108 512 904
DE-A1- 102016 002 267
MEYER M ET AL: "Frequency response measurements on railway traction units", EB - ELEKTRISCHE BAHNEN, vol. 105, no. 10, 1 October 2007 (2007-10-01), DE, pages 521 - 527, XP055778815, ISSN: 0013-5437
DASH K ET AL: "FAST ESTIMATION OF VOLTAGE AND CURRENT PHASORS IN POWER NETWORKS USING AN ADAPTIVE NEURAL NETWORK", IEEE TRANSACTIONS ON POWER SYSTEMS, IEEE SERVICE CENTER, PISCATAWAY, NJ, US, vol. 12, no. 4, 1 November 1997 (1997-11-01), pages 1494 - 1499, XP011050561, ISSN: 0885-8950

System for the combined location-, time- and frequency-dependent determination of electrical parameters in a power supply network

The invention relates to a system for the combined location-, time- and frequency-dependent determination of electrical parameters in a power supply network. In electrical systems, superimpositions of the location-, time- and frequency-dependent electrical parameters frequently occur, which lead to faults, for example in network equipment and consumers, as well as to faults in network operation. The instabilities in grid operation are caused by resonances that can arise from the operation of grid converters. This leads to a reduction in voltage quality and even to grid instabilities and grid failures to which no clearly defined cause can be assigned.

Typical fields of application in which such faults occur in grid equipment and consumers as well as faults in grid operation are e.g:

- 15 - Drives or generators with frequency converters, e.g. speed-controlled drives in production facilities, loading equipment such as conveyor belts, cranes; wind farm installations
- Electric rail networks for passenger and freight transportation
- Local rail networks, such as subway, suburban rail, streetcar, trolleybus networks
- 20 - Electric trunk roads, such as overhead line networks for trucks
- Electrical wiring systems in motor vehicles, ships/submarines and aircraft

The following source addresses such network failures in the Swiss rail network:

Markus Meyer, Wettingen; Martin Aeberhard, Zollikofen; Kaspar Germann, Bern; Rolf Suter, Thun; Peter Dahler, Turgi: Messung des Frequenzgangs von Triebfahrzeugen, eb
25 105 (2007) Heft 10, S. 521-527.

Up to now, attempts have been made to prevent faults in network equipment and consumers by monitoring time-dependent electrical parameters such as voltage and current separately and by monitoring frequency-dependent electrical parameters such as voltage and current harmonics and the switch-off limit values derived from these independently.

DE 10 2016 002 267 A1 discloses an arrangement and a method for measuring the electrical properties at the connection point of an electrical power supply network, of generators, consumers or sub-networks connected to it. WO 2015/168260 A1 discloses a smart
35

- 2 -

sensor network for local condition monitoring in a power supply network. EP 3 336 995 A1 discloses a method, a control device and a system for determining status values for describing operating states in a sub-grid of a power supply network.

- 5 The invention is based on the task of providing a system with which such faults in the power supply network can be identified and avoided even more effectively.

This task is solved by a system according to claim 1. Advantageous embodiments are described in the subclaims.

10

- a) The system has an excitation system that is set up to randomly feed at least one electrical excitation signal into the power supply network,
- b) the system has a measuring system which is set up to determine electrical parameters occurring in the power supply network as a result of the electrical excitation signal as a function of location, time and frequency,
- 15 c) wherein the measuring system has a sensor system which has a plurality of sensors distributed locally over the energy supply network and/or location-variable sensors, by means of which electrical parameters in the energy supply network can be determined at different locations and accordingly in a location-dependent manner.

20

With such a system, the following previously unsolved problems can be solved in a simple and cost-effective way:

- Previously undetected location-dependent electrical parameters generate additional interference potentials that lead to undesired shutdowns, e.g. the long-known propagation of traveling waves in 110 kV high-voltage and 220 or 380 kV extra-high-voltage grids.
- 25 - The starting and braking of electric traction units of electric railroads in railroad, suburban railroad, subway railroad and tramway operation generates location-dependent starting and braking currents, the effect of which cannot be calculated online using existing measurement and evaluation methods.
- 30 - This applies to all voltage levels, i.e. low voltage up to 1 kV, medium voltage up to 52 kV, high voltage up to 150 kV with standardized voltage values of 110 kV, extra-high voltage above 150 kV with standardized voltage values of 220 kV and 380 kV and ultra-high voltage with voltage values above 500 kV

- 3 -

- This applies at all voltage levels for 50 Hz and 60 Hz AC and three-phase networks, as well as for 16 2/3 Hz AC networks and DC networks of electric railroads and also high-voltage DC networks
- As a result, the interference potentials cannot be classified to such an extent that they can be protected against selectively, i.e. well localized.
- This leads to failures of electric railroads.
- This results in grid shutdowns in the 110 kV high voltage and 220 and 380 kV extra-high voltage grids.
- This leads to grid shutdowns in the high-voltage direct current grids.
- Due to the lack of combined location-, time- and frequency-dependent online identification of electrical networks, it is not possible to reliably distinguish between permissible normal operation and fault operation, particularly in the area of electrical railroad networks.
- Due to the lack of procedures for the combined location-, time- and frequency-dependent online identification of electrical networks, no practical tests of electrical equipment, components and systems can be defined.

In the system according to the invention, a location-dependent component for determining the electrical parameters in the energy supply network is therefore also proposed.

- This is achieved by the fact that the measuring system has a sensor system which has a large number of sensors distributed locally over the power supply network, which can, for example, be arranged in a fixed location, and/or location-variable sensors. The location-variable sensors can either be controlled randomly at a specific, desired location or are located, for example, on a means of transportation that moves along the energy supply network.

- The combined location-, time- and frequency-dependent properties of electrical systems are to be determined. These are decisive for the function of electrical equipment and connected loads. An electrical system is defined here as an individual component or the entirety of the network equipment, such as cables, lines, transformers, compensation systems, including the electrical consumers and electrical generators connected to the network. Design of the device: Device for connection to electrical consumers (absorbs electrical energy) and producers (supplies electrical energy) or combined consumers/producers, so-called prosumers, which work temporarily as consumers and temporarily as producers.

- 4 -

For example, a stationary fixed, stationary "traveling" (fixed and traveling) or transient moving (locally variable) sensor system is used to record the location dependency. The time- and frequency-dependent parameters of electrical systems are additionally measured as a function of location, e.g. by sensors moving along the electrical cables, and

- 5 linked to the time- and frequency-dependent parameters. This is done, for example, by
1. A permanently installed "traveling" sensor system that moves within the electrical system, e.g. in vehicles that are electrically coupled to the grid, e.g. in electric rail vehicles. The measured variables can be determined passively or actively. This is a locally moving measurement, e.g. using conventional sensors or measuring devices,
10 of location-, time- and frequency-dependent electrical parameters
 2. Local mobile measurement using mobile sensors, e.g. mobile high-voltage electrodes for measuring voltages on overhead lines, time and frequency-dependent electrical parameters
 3. Movement of voltage and current sensors along electrical systems, e.g. along overhead lines, with mechanically guided (e.g. suspended on rollers on conductor cables) or mechanically unguided (e.g. drones) traversing devices for recording location-, time- and frequency-dependent electrical parameters
15

According to an advantageous embodiment of the invention, it is provided that the excitation system has an actuator system which has a plurality of actuators distributed locally
20 over the energy supply network and/or location-variable actuators, by means of which electrically defined synchronous or asynchronous excitation signals with defined pulse patterns can be fed into the energy supply network at different locations. This has the advantage that the excitation signals can be fed into the energy supply network at different
25 locations as required. The actuators can be arranged at a common location with one or more sensors, or at different locations from the sensors. Location-variable actuators can be combined locally with location-variable sensors so that only one common actuator is required to change the location of the sensor and the actuator.

30 Suitable excitation signals are voltages or currents or impedances as well as possible combinations thereof, which are switched to the power supply network. Such excitation signals can be switched in pulse patterns with fixed or variable switch-on and pause times. Pulse patterns are time-defined connections of voltage and/or current signals and/or electrical impedances with any frequencies from 0 Hz (constant value) up to frequencies in the MHz range as periodic or one-off values (pulse). The time-defined con-
35

nection takes place with a fixed or variable switch-on and pause time. Synchronous excitation signals have temporally common zero crossings with the fundamental frequency of the power supply network to be measured. Asynchronous excitation signals have no common zero crossings with the fundamental frequency of the power supply network to be measured.

According to the invention, the system is provided with an evaluation system which is set up to evaluate the location-, time- and frequency-dependent electrical parameters of the power supply network and to generate a representation of the electrical parameters or electrical system responses of the power supply network determined therefrom with at least local and temporal resolution. This allows fast and reliable diagnosis of the aforementioned network faults.

According to the invention, it is provided that the evaluation system is set up to generate one, several or all of the following representations of the electrical parameters or electrical system responses of the power supply network determined therefrom:

- a) Representation of location over time and electrical quantities,
- b) Representation of the time via the location and the electrical variables,
- c) Representation of electrical variables over time and location.

The evaluation system can advantageously be set up to generate the respective representation by means of a real-time online calculation of variables derived from the time-, location- and frequency-dependent parameters.

According to feature a), a map of time and electrical quantities is created. According to feature b), a time map of the location and electrical quantities is created. According to feature c), an electro-time map of the electrical variables is created for different times and locations. This considerably expands and improves the diagnostic options for network faults.

According to an advantageous embodiment of the invention, the system is set up to continuously feed electrical excitation signals into the energy supply network via the excitation system during real operation of the energy supply network and to determine electrical parameters occurring in the energy supply network as a result of the excitation sig-

nals via the measuring system depending on the location, time and frequency. The system therefore allows online identification of grid faults at any time, even in real-time operation.

5 According to an advantageous embodiment of the invention, it is provided that the measuring system is set up to store the location-, time- and frequency-dependent electrical parameters of the power supply network and/or mathematically determinable parameters derived therefrom in a time-synchronized manner. This has the advantage that a large number of parameters determined via the measuring system can be stored, which can
10 subsequently be evaluated synchronously with each other, for example statistically.

According to an advantageous embodiment of the invention, it is provided that the excitation system is set up to feed electrical excitation signals into the power supply network at excitation times that are evenly or unevenly spaced apart, or with a combination of
15 evenly and unevenly spaced excitation times. This considerably expands and improves the diagnostic options for grid faults.

This allows, for example, the realization of synchronous-sub-asynchronous excitation and measurement methods for the combined location-, time- and frequency-dependent
20 online identification of electrical systems. In this way, the electrical system in question can be excited synchronously-sub-asynchronously in time by the excitation signals. Synchronous in time means that the time intervals between the excitation times or between the measurement times are always constant in time. Temporally asynchronous means that the time intervals are variable. Temporally synchronous-sub-asynchronous means
25 that in addition to temporally constant (synchronous) excitations and measurements, there are also temporally variable excitations and measurements.

This can be carried out with active processes, e.g. by exciting the system and measuring as follows:

- 30 I. with a temporally constant (equal distances between the excitation signals) or temporally variable (unequal distances between the excitation signals) synchronous excitation (simultaneous in all conductors) of multi-conductor systems
- II. Parallel to this, a time-constant or variable individual excitation of the phase conductors takes place; this individual excitation can take place synchronously or asyn-
35 chronously with the signals from II

- III. Single-line systems can be excited/measured synchronously or asynchronously with constant or variable timing

According to an advantageous embodiment of the invention, the measuring system is set up to determine additional electrical parameters in the energy supply network as a function of location, time and frequency, even without feeding in electrical excitation signals. In this way, the system also supports passive measurement methods. This allows further information to be obtained about the energy supply grid, further improving the diagnosis of grid faults.

10

This means that both passive and active measurement methods can be used.

Definition of passive measurement methods: Methods that exclusively record measured variables already present in electrical systems without active excitation, i.e. passively measure, e.g. voltage/current/frequency, voltage/current harmonics, frequency deviations.

15

Definition of active measurement methods: Methods that actively excite an electrical system by means of excitation signals (e.g. by switching on an electrical load or an electrical consumer), thus generating a "reaction" of the system (e.g. a voltage dip) and measuring the reaction to the excitation.

20

For the complete identification of electrical system parameters, it is advantageous to record their location-, time- and frequency-dependent behavior. This is to be achieved by an interdependent combination of the following parameters:

1. Location-dependent determination of electrical parameters
- 25 2. Time-dependent determination of electrical parameters
3. Frequency-dependent determination of electrical parameters
4. location (also: distance)-time measurement synchronization, i.e. the assignment of measured values to time and location coordinates

30 The sensors for location-, time- and frequency-dependent measured variables, which can be installed together or separately, provide output signals that are recorded synchronously per measuring cycle.

Figure 1 shows a schematic representation of a system according to the invention for the combined location-, time- and frequency-dependent determination of electrical parame-

35

ters in a power supply network 3. The system has a measuring system 2 and an excitation system 1. The measuring system 2 records the location-, time- and frequency-dependent measured variables via measuring sensors 5, e.g. measuring transformers. The excitation system 1 excites the electrical system 3 and thus generates a reaction, e.g. a change in the voltage amplitude. In the example shown, both the excitation system 1 and the measuring system 2 are arranged on a mobile carrier which is variable in position, i.e. which can be moved relative to the electrical system 3.

Figure 2 shows an example of the procedure for feeding excitation signals into the power supply network and recording the electrical parameters occurring in the power supply network via the measuring system 2. According to block 20, the excitation system 1 uses a signal generator to generate an excitation signal that is to be impressed into the power supply network 3. According to block 21, the excitation signal is then physically impressed into the power supply system 3 by an actuator. The impressed excitation signal generally generates a change in one or more electrical parameters in the power supply system 3. In a block 22, the location, time and electrical response of the power supply system 3 are then measured using sensors or transducers of the measuring system 2. In a block 23, the measured variables recorded synchronously in block 22, namely the location, time and electrical system response of the power supply system 3, are stored, as shown in Figure 3.

After storing a large number of such recorded measured variables, i.e. after running through the blocks 20 to 23 several times, in particular at different locations of the power supply network 3, a statistical evaluation of the stored time-synchronous measured variables can be carried out in block 24, e.g. averaging and calculation of the standard deviation per path element, per time point and per calculated electrical variable as well as of average values and standard deviations of the coupled measured variables. Block 25 can then be used to create a spatially and temporally resolved representation of the electrical system responses. In particular, as shown in block 26, three "maps" or dependencies can be created or displayed: Creation of a "map" of the time and electrical quantities ("network google": path/time/electrical quantities), a "time map" of the location and electrical quantities ("network path clock": time/location/electrical quantities) and an "electrical time map" of the electrical quantities for different times and locations (electrical time map: electrical quantities/time/location/).

In addition, according to block 27, a permanent online supplementation, correction and refinement of the "map" and "time map" of the stored synchronous measured variables can be carried out, i.e. a continuous updating of the representations by running through the procedure again and again.

5

Figure 3 schematically shows the time-synchronous recording of the measured values in the measuring system 2 and the time-synchronous storage, e.g. in the form of a table 9. The measuring system 2 can have a transducer 6 for time-dependent measured variables, a transducer 7 for location-dependent measured variables and a transducer 8 for

10

The invention can be extended with a time-stepped excitation and measurement method for the combined location-, time- and frequency-dependent online identification of electrical systems. Figure 4 shows the time-stepped excitation of each desired point on the voltage or current curve. The electrical system to be analyzed is to be excited continuously in adjustable time steps or only point by point as a sampling series or single point of the measured variable time curve. This is shown in Figure 4 using an example of a voltage or current-time curve. This applies to all the parameters to be measured, which can be purely physical parameters or mathematically calculated parameters.

15

20

Figure 5 shows at least a part of the excitation system 1, in particular an embodiment of its actuators 4. In active measurement methods, i.e. measurement methods that actively excite an electrical system and measure the response to the excitation, an excitation system is to be used for any electrical system. The

25

The excitation system can be used for any stationary or mobile electrical systems. The stationary or mobile electrical systems can be part of an overall electrical system.

The excitation system 1 shown in Figure 5 works by connecting passive linear or non-linear components, active sources or components or any combination thereof, e.g. by connecting:

30

- a) Ohmic resistance
- b) Inductance
- c) Capacity
- d) Electrical energy storage in the form of batteries, accumulators
- e) Rotating electrical energy converters in the form of motors or generators

35

- f) Arbitrarily adjustable counter voltage with phase position or phase sequence deviating from the measured object (in particular below or above a voltage of an active measured object)
- g) Any adjustable positive sequence voltage with the phase position or phase sequence of the measurement object (in particular below or above a voltage of an active measurement object)

The excitation system 1 as shown in Figure 5 also works with any mixed forms of connection from a) to g) in the form of a consumer or generator.

10

With the measurement method used, the reaction of the electrical system to the excitation is measured using the connection from a) to g).

Location-, time- and frequency-dependent electrical parameters are recorded. A parameter can be a physical (measured) variable, but also a mathematically calculated (computed) variable.

15

A. Time-dependent electrical parameters K_t are:

- a) Direct time-dependent parameters such as voltage, current, frequency
- b) Calculated time-dependent variable products such as active, reactive and apparent power
- c) Calculated time-dependent differential quantities for time differences, e.g. t_2-t_1 , such as voltage difference, voltage rise and fall (du/dt), current difference, current rise and fall (di/dt), frequency difference, frequency rise and fall (df/dt), power difference, power rise and fall (dP/dt), System impedance difference, system impedance rise and fall (dZ/dt)
- d) Flow directions of the current and power
- e) Temporal changes of spectral quantities, i.e. time-frequency dependencies

20

25

The sensors for time-dependent electrical parameters provide measured values $x = f(K_t, t)$

B. Frequency-dependent electrical parameters K_f are:

- a) Direct time-dependent parameters such as voltage, current, frequency
- b) Calculated time-dependent variable products such as active, reactive and apparent power

30

35

- 11 -

- c) Calculated time-dependent differential quantities for time differences, e.g. t_2-t_1 , such as voltage difference, voltage rise and fall (du/dt), current difference, current rise and fall (di/dt), frequency difference, frequency rise and fall (df/dt),
- 5 power difference, power rise and fall (dP/dt),
Mains impedance difference, mains impedance rise and fall (dZ/dt)
- d) Flow directions of the current and power
- e) Spectral representations of the frequency-dependent electrical parameters a) to d), i.e. online spectral analyses of the parameters a) to d)
- 10 The sensors for frequency-dependent electrical parameters provide measured values $x = f(K_f, f)$
- C. Location-dependent electrical parameters K_o are:
- All sizes listed under A. and B. with additional local allocation
- 15
- D. Path-time synchronization
- The sensors for location-dependent electrical parameters provide measured values $x = f(K_o, f)$
- 20 Path-time synchronization: Start at reference point $x_0(t_0)$, $\Delta x = x_0 + x(t_0 + t)$, then $\Delta x = v \cdot t$.
- E. Determination of differential parameters
- E.g. differential path impedance determination, dynamic differential path impedance de-
- 25 termination in the frequency range, dynamic fault direction determination for overvoltages and overcurrents, dynamic differential path spectral quantities

P A T E N T K R A V

1. System til kombineret sted-, tids- og frekvensafhængig bestemmelse af elektriske parametre i et energiforsyningsnet (3) med følgende karakteristiske træk:

a) systemet omfatter et stimuleringsystem (1), der er indrettet til vilkårligt at tilfø-
5 re til energiforsyningsnet (3) mindst ét elektrisk stimuleringsystem,

b) systemet omfatter et målesystem (2), som er indrettet til at bestemme elektriske parametre, der forekommer i energiforsyningsnet (3) som følge af det elektriske stimuleringsignal som en funktion af placering, tid og frekvens,

c) hvor målesystemet omfatter et sensorsystem (5), som har flere sensorer, der er
10 fordelt lokalt over energiforsyningsnet (3) og/eller stedvariable sensorer, ved hjælp af hvilke elektriske parametre i energiforsyningsnet (3) kan bestemmes på forskellige steder og følgelig på en stedafhængig måde,

hvor systemet omfatter et evalueringssystem, der er indrettet til at evaluere de
15 sted-, tids- og frekvensafhængige elektriske parametre i energiforsyningsnet (3) og til at fremstille en i det mindste rumligt og tidsmæssigt opløst fremstilling af de elektriske parametre eller elektriske systemresponsen i energiforsyningsnet (3), der bestemmes derfra, kendetegnet ved, at evalueringssystemet er indrettet til at fremstille alle efterfølgende fremstillinger af de elektriske parametre eller elektriske systemresponsen i energiforsyningsnet (3), der er bestemt derfra:

20 d) fremstilling af sted i form af tid og elektriske mængder ved at danne et kort over tid og elektriske mængder,

e) fremstilling af tiden via stedet og de elektriske mængder ved at danne et tidskort over stedet og de elektriske mængder,

f) fremstilling af de elektriske mængder over tid og sted ved at danne et elektrotids-
25 kort over de elektriske mængder for forskellige tidspunkter og steder.

2) System ifølge krav 1, kendetegnet ved, at evalueringssystemet er indrettet til at identificere interferenspotentialer i energiforsyningsnet (3) ud fra kombinationen af de sted-, tids- og frekvensafhængige elektriske parametre i energiforsyningsnet (3).

3) System ifølge krav 1 eller 2, kendetegnet ved, at stimuleringsystemet (1) har et
30 aktuatorsystem (4), som har en flerhed af aktuatorer fordelt lokalt over energiforsyningsnet (3) og/eller stedvariable aktuatorer, ved hjælp af hvilke definerede tidsmæssigt

synkrone eller asynkrone elektriske stimulerings signaler med definerede impulsmønstre kan tilføres energiforsyningsnettet (3) på forskellige steder.

4) System ifølge krav 1 eller 2, kendetegnet ved, at evalueringssystemet er indrettet til at fremstille den respektive fremstilling ved hjælp af en realtids-onlineberegning af 5 variabler, der er afledt af de tids-, sted- og frekvensafhængige parametre.

5) System ifølge et hvilket som helst af foregående krav, kendetegnet ved, at systemet er indrettet til kontinuerligt at tilføre elektriske stimulerings signaler til energiforsyningsnettet (3) via stimulerings systemet (1) under den faktiske drift af energiforsyningsnettet (3) og til at bestemme elektriske parametre, der forekommer i energiforsyningsnettet (3) som et resultat af stimulerings signalerne på en sted-, tids- og frekvensafhængig 10 måde via målesystemet (2).

6) System ifølge et hvilket som helst af foregående krav, kendetegnet ved, at målesystemet (2) er indrettet til at lagre de sted-, tids- og frekvensafhængige elektriske parametre i energiforsyningsnettet (3) og/eller matematisk bestemte parametre, der er afledt 15 heraf, på en tidssynkron måde.

7) System ifølge et hvilket som helst af foregående krav, kendetegnet ved, at stimulerings systemet (1) er indrettet til at tilføre elektriske stimulerings signaler til energiforsyningsnettet (3) på stimulerings tider, som er jævnt eller ujævnt fordelt, eller med en kombination af jævnt og ujævnt fordelte stimulerings tider.

8) System ifølge et hvilket som helst af foregående krav, kendetegnet ved, at målesystemet (2) er indrettet til at bestemme yderligere elektriske parametre i energiforsyningsnettet (3) som en funktion af sted, tid og frekvens, selv uden tilførsel af elektriske stimulerings signaler. 20

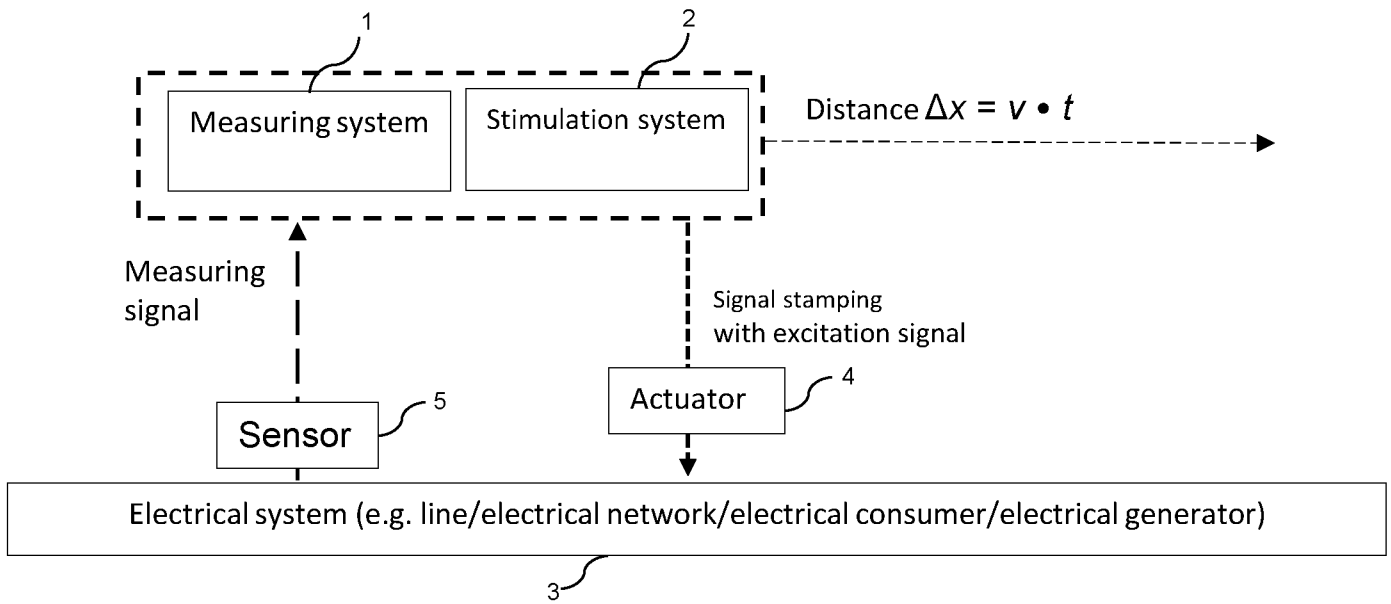

Fig. 1

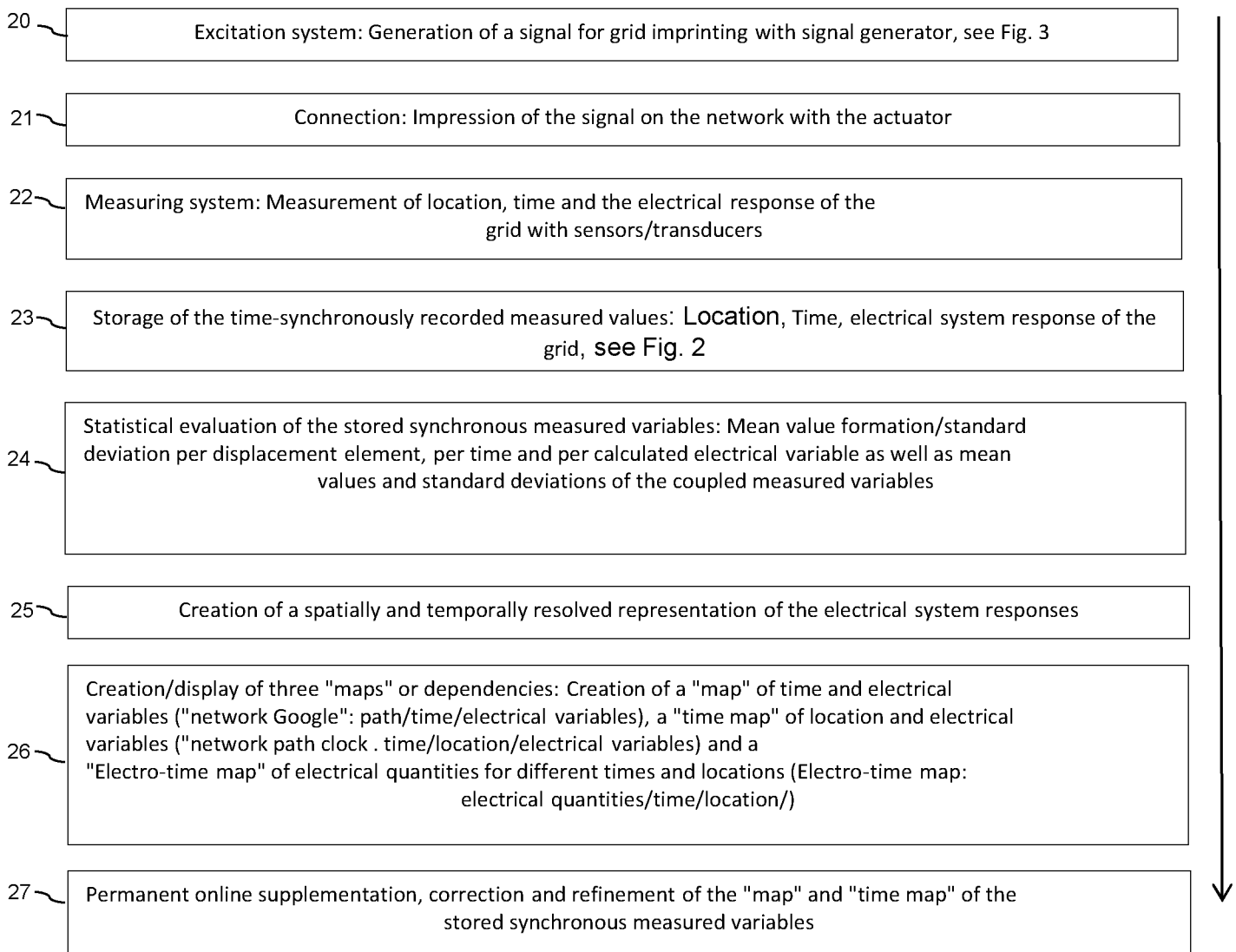

Fig. 2

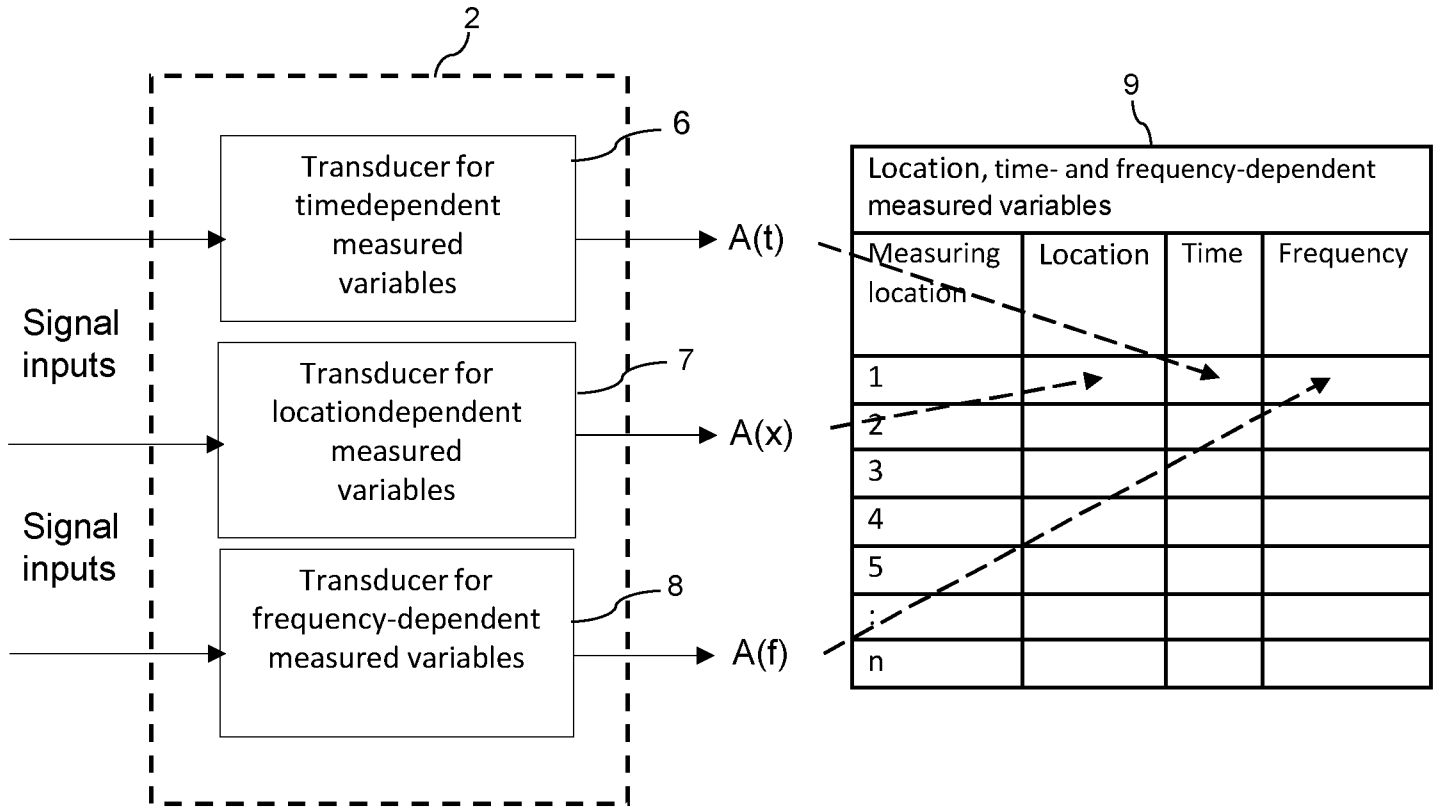

Fig. 3

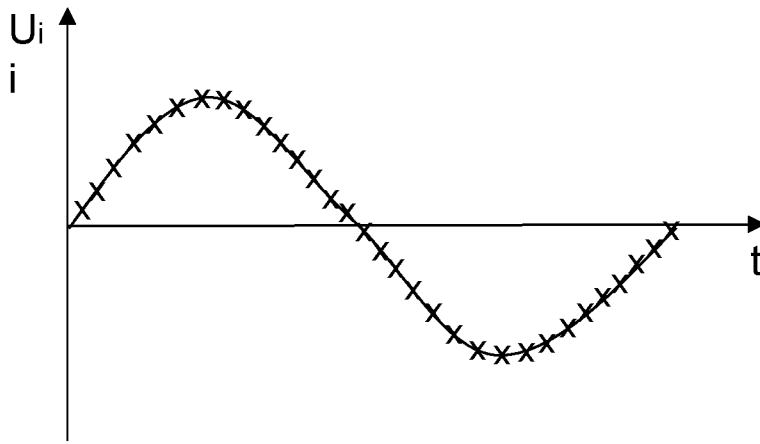

Fig. 4

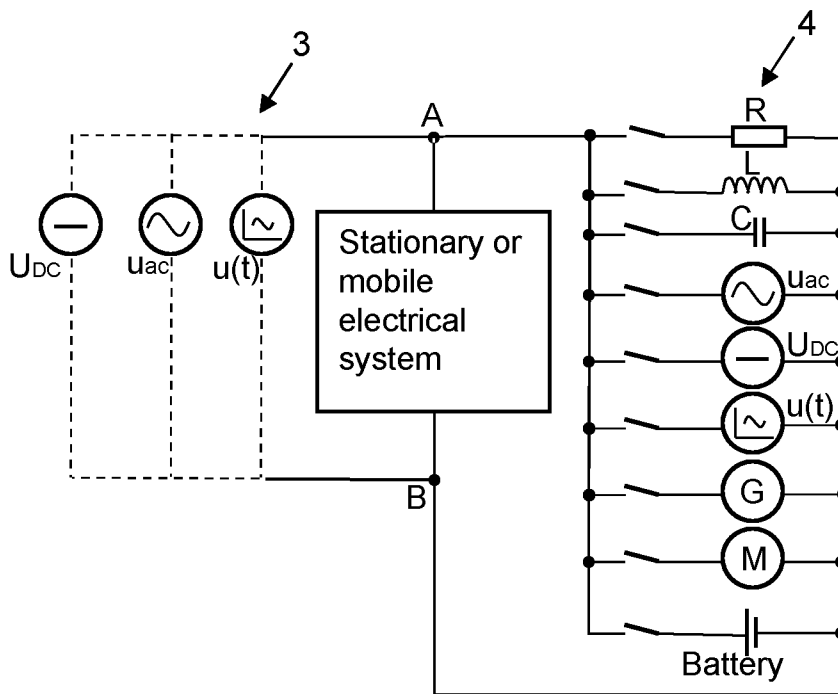

Fig. 5