

P. MEINELT & H. REHM.
 EMBROIDERING MACHINE.
 APPLICATION FILED AUG. 29, 1908.

947,352.

Patented Jan. 25, 1910.

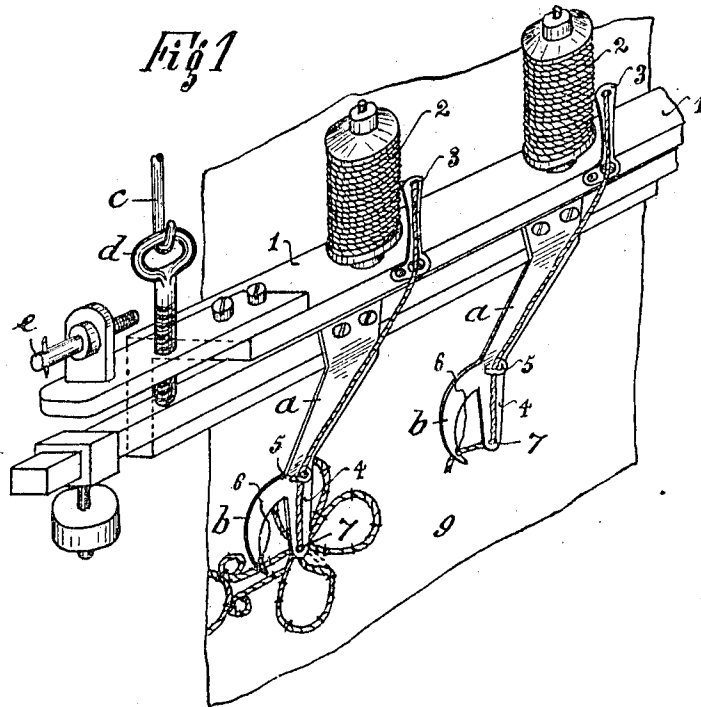
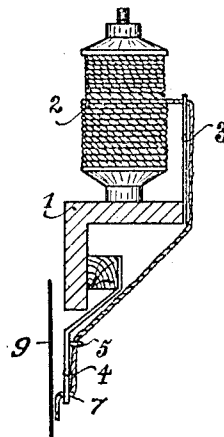

Fig. 2



Witnesses
H. C. Barkley
amv Lerch

INVENTORS
 Paul Meinelt
 Heinrich Rehm
 by *Frank. Adlemay*
 ATTORNEY.

UNITED STATES PATENT OFFICE.

PAUL MEINELT, OF EIBENSTOCK, AND HEINRICH REHM, OF SCHNEEBERG, GERMANY.

EMBROIDERING-MACHINE.

947,352.

Specification of Letters Patent.

Patented Jan. 25, 1910.

Application filed August 29, 1908. Serial No. 450,812.

To all whom it may concern:

Be it known that we, PAUL MEINELT and HEINRICH REHM, subjects of the German Emperor, residing, respectively, at Eibenstock and Schneeberg, both in Saxony, Germany, have invented certain new and useful Improvements in Embroidering-Machines and the Like, of which the following is a specification.

10 This invention relates to an improvement in embroidering machines for fastening threads, in embroidery work and the like, so that they lie upon the cloth without passing through the fabric. This kind of work is sometimes called "application embroidery." The respective thread, for example a gold thread or the like, must be so guided that the needles drawing the embroidery threads proper fasten or sew the applied thread onto the fabric. The arrangement may also be applied to sewing machines and the like and consists of a special thread guide, but the function and construction of the embroidering machine are not modified in any way.

The invention is illustrated in the annexed drawing, in which—

Figure 1 is a perspective elevation and Fig. 2 a cross section showing the bar carrying the spools of "applied" thread and the thread guides.

1 is a bar, which is suspended by hooks such as *c* and eyes such as *d* and has abutments such as *e* for limiting its lateral movement. The bar 1 is movable by the attendant so as to take part in all the movements of the embroidering needle frames or bars. On the bar 1 are arranged spools 2 of the threads to be "applied." Additional variety of pattern may be obtained by having threads of various kinds and colors on these spools. In front of each of the spools 2 there is a thread guide 3, which takes off the thread, through an eye, and passes it to the thread applying device or layer-on 4, comprising a substantially vertical but rearwardly bent member *a* having at its lower end a hole 7 and at some dis-

tance above the latter an eye 5 on its face. Laterally from the member *a* there branches a downwardly curved member *b* having a notch 6 at its lower end substantially level with the hole 7. The thread passes through the eye 5, and through the hole 7 which guides it to the fabric 9, *i. e.*, to the cloth to be embroidered. The hole 7 draws the thread from its last fastening point to the next fastening point, and the embroidery needles are thus enabled to fasten the applied thread by a double stitch which makes a loop over the applied thread. After the first passage of the needle the embroiderer gives to the bar 1 a small movement either vertically or horizontally so that the needle holes are on both sides of the thread.

To allow of beginning the embroidery the lateral member *b* has the notch 6 in which the loose end of the thread can be placed by hand. The thread held fast by this notch can be fastened to the fabric by a stitch when the embroidering is commenced, and the loose end can be afterward cut off where the pattern begins.

In view of the fact that hitherto threads could not be so applied, by means of an ordinary machine, that they really lie upon the cloth, the very simple thread-guide provided for that purpose by the present invention constitutes an important improvement in embroidering apparatus.

It will be understood that the various parts of the embroidering machine remain unaltered and it is therefore unnecessary to illustrate the machine.

What we claim as our invention and desire to secure by Letters Patent of the United States is:—

1. In an embroidery machine the combination of a bar movable before the fabric to be embroidered, spools on said movable bar, and thread guides thereon having means for guiding the threads over the surface of the said fabric.

2. In an embroidery machine the combination of a bar movable before the fabric to be embroidered, spools on said movable bar, and

thread guides thereon each comprising a vertical rearwardly bent member having a thread hole in the lower end thereof for guiding the threads over the surface of the
5 said fabric.

3. In an embroidering machine the combination of a bar movable before the fabric to be embroidered, spools on said movable bar, thread guides thereon having means for
10 guiding the threads over the surface of the

said fabric and notched lateral arms to said thread guides for the purpose set forth.

In witness whereof we have signed this specification in the presence of two witnesses.

PAUL MEINELT.
HEINRICH REHM.

Witnesses:

ULRICH BIGELOW,
CHARLES LUHTMANN.