

J. C. WRENSHALL.

Car Coupling.

No. 104,679.

Patented June 21, 1870.

FIG 1.

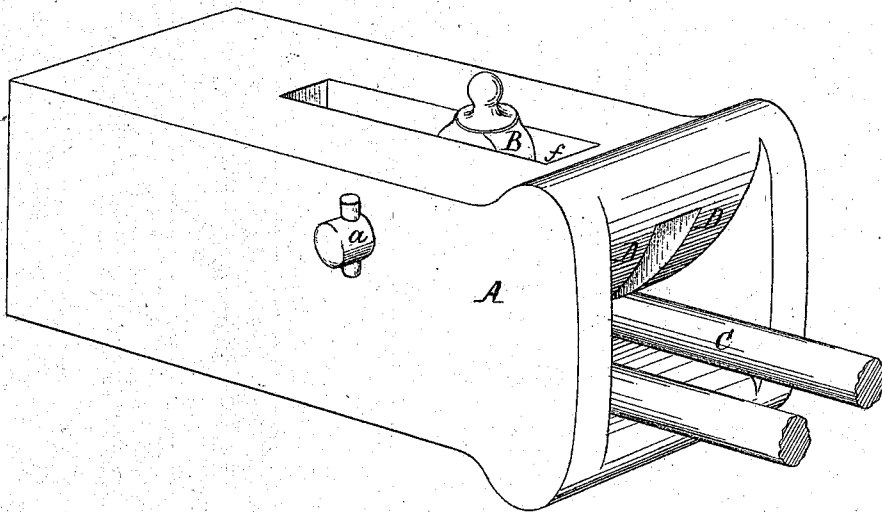
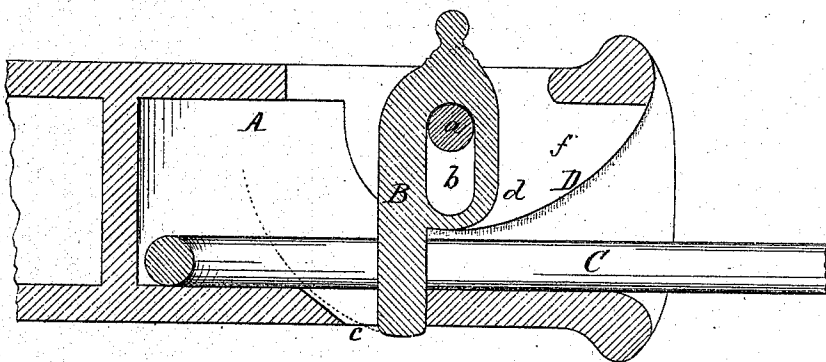

FIG 2.



WITNESSES.

*Wm. D. Saylor*  
*Chas. W. Saylor*

*John C. Wrenshall*  
*by his attorney*

*A. Pollitt*

# United States Patent Office.

JOHN C. WRENSHALL, OF BALTIMORE, MARYLAND.

Letters Patent No. 104,679, dated June 21, 1870.

## IMPROVEMENT IN CAR-COUPLING.

The Schedule referred to in these Letters Patent and making part of the same

### To whom it may concern :

Be it known that I, JOHN C. WRENSHALL, of the city and county of Baltimore and State of Maryland, have invented certain new and useful Improvements in Car-Couplings, of which the following is a specification.

My invention consists in the combination, with the bumper of a railway car and cheek-pieces arranged in the same, of a slotted coupling-pin adapted to move up and down, and to swing backward and forward in the bumper, and a transverse pin, which is held by the said cheek-pieces, and forms the support for the upper end of the coupling-pin, as hereinafter described.

In a coupler made in accordance with my invention, the pin can, when its lower end is not caught in the hole or socket formed for it in the bottom of the bumper, swing forward as freely as it can backward, so that, in case the link is not slack enough to permit the pin to be forced down into the lower hole, the pin, when the link is drawn forward, will freely move or swing in the same direction, and will not hold the link.

This prevents the pin from being strained or broken, and renders it impossible for the coupling to take place, unless the pin is brought to its proper position.

The transverse pin, upon which the coupling-pin is suspended, passes through the cheek-pieces in the bumper, and there is only sufficient of its length exposed to allow it to receive the slotted coupling-pin, which is placed between the cheek-pieces, so as to reduce to the minimum all danger of the transverse pin breaking or yielding to the strain to which it is subjected.

The cheek-pieces give additional strength to the bumper and transverse pin, and serve to guide the coupling-pin in all its movements.

The nature of my invention, and the manner in which the same is or may be carried into effect, will be readily understood by reference to the accompanying drawing, in which—

Figure 1 is a perspective view of a bumper and pin, made in accordance with my invention.

Figure 2 is a longitudinal vertical section of the same.

A is the bumper or draw-head of a railway-car, made of cast or wrought metal, and of the usual form and construction, except in the features hereinafter referred to.

With this bumper I combine a draw-pin, B, suspended upon a transverse pin, *a*, and slotted or equivalently-formed, so that it may be drawn up or lowered, as occasion requires.

The slot *b*, in this instance, is formed by bending over the end of the pin, as shown in fig. 2.

In the lower part or bottom of the bumper is a socket or hole, *c*, for the end of the pin, which hole is of such size and dimensions as to permit the end of the pin to swing back out of it, when pushed by the entering link.

The pin is not only so arranged as to swing backward in the usual manner, but can as freely swing forward, that is to say, forward of a vertical plane, passing longitudinally through the axis *a*, when the end of the pin is not dropped in the socket *c*.

This I accomplish by cutting away, slotting, or otherwise forming the upper part of the bumper, as shown at *f*, so that the pin is perfectly free, when not forced into the socket *c*, to swing forward and allow the link to be drawn out, without offering any resistance.

After the link has thus been drawn out, the lower end of the pin will rest on the bottom of the bumper forward of the hole *c*, but, upon the re-entering of the link, it is pushed back, the slot *b*, permitting this motion, and, in fact, in whatever position the pin may be in, it is ready for the link, which, upon entering the bumper, will push it back, and then, having passed back far enough, will allow the lower end to swing forward into the socket *c*, and thus effect the coupling.

It is, indeed, impossible to get the pin in any position in which it will be jammed and injuriously strained, as it will not hold or resist the link, until it drops fully into the socket *c*.

In order to strengthen the bumper, and to properly support and guide the coupling-pin, I form in the metallic bumper-cheeks D one on each side of the pin, and of suitable size and conformation. These cheeks serve to stiffen the bumper, and give it increased strength, and are also useful in preventing the lateral movement of the pin, and holding it in proper position to receive the link.

The transverse pin *a* holds the coupling-pin and sustains the strain which comes upon the upper part of the coupling-pin, when the cars are in motion.

In order, therefore, to fit it for this use, it is arranged to pass through the cheek-pieces D, which are only so far apart as to expose just enough of the pin *a* to adapt it to receive the coupling-pin. This portion of the bumper is consequently very strong, and the pin *a* will not bend or buckle, and can only be incapacitated for use by being sheared or cut off, which accident, owing to the small extent of the pin exposed, is most unlikely to occur.

It will thus be seen that, in case the cars should be drawn apart before the vertical pin enters the lower slot or hole, the pin will come forward, and thereby prevents breaking or bending of the same.

Another advantage is that this coupling is very simple and readily made, and can be used on one car, while

the cars in front or rear may be supplied with the old style of coupling. There is also no need of guiding the link, as it rests on the bottom of the bumper with more of its length in the bumper than out of it, and, as the rear of the bumper is closed, the link will be forced forward into the next bumper far enough to allow the pin of that bumper to lock it.

The length of the link should be about one-half inch less than the distance from back to back of the bumpers, when they are in contact.

Having now described my invention, and the manner in which the same is or may be carried into effect,

What I claim, and desire to secure by Letters Patent, is—

The combination, with the bumper and cheek-pieces in the same, of the slotted coupling-pin and the transverse pin, from which it is suspended, said parts being arranged for joint operation, as herein shown and set forth.

In testimony whereof I have signed my name to this specification before two subscribing witnesses.

Witnesses:

J. C. WRENSHALL.

M. BAILEY,

EDM. F. BROWN.