

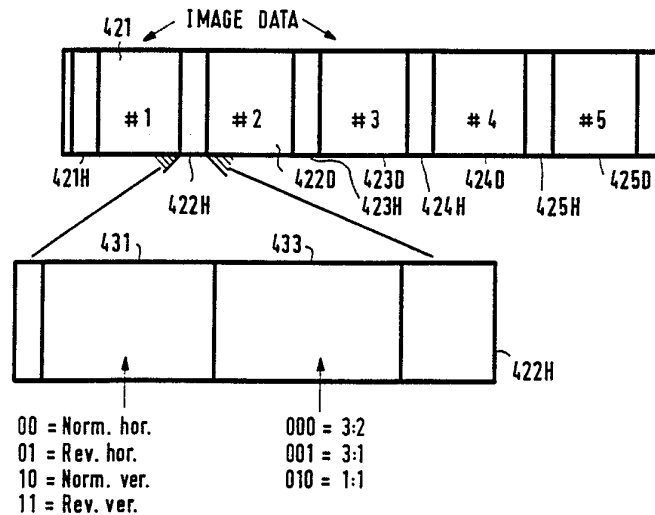

INTERNATIONAL APPLICATION PUBLISHED UNDER THE PATENT COOPERATION TREATY (PCT)

<p>(51) International Patent Classification ⁵ : H04N 1/21, 1/387, 9/80</p>	<p>A2</p>	<p>(11) International Publication Number: WO 92/05652 (43) International Publication Date: 2 April 1992 (02.04.92)</p>
<p>(21) International Application Number: PCT/NL91/00168 (22) International Filing Date: 13 September 1991 (13.09.91) (30) Priority data: 90202487.6 19 September 1990 (19.09.90) EP (34) Countries for which the regional or international application was filed: DE et al. 9002110 27 September 1990 (27.09.90) NL (71) Applicant (for all designated States except US): N.V. PHILIPS' GLOEILAMPENFABRIEKEN [NL/NL]; Groenewoudseweg 1, NL-5621 BA Eindhoven (NL). (72) Inventor; and (75) Inventor/Applicant (for US only) : TIMMERMANS, Josef, Maria, Karel [BE/BE]; Kempische Steenweg 293, B-3500 Hasselt (BE).</p>	<p>(74) Agent: ROLFES, Johannes, Gerardus, Albertus; Internationaal Octrooibureau B.V., P.O. Box 220, NL-5600 AE Eindhoven (NL). (81) Designated States: AT (European patent), AU, BB, BE (European patent), BF (OAPI patent), BG, BJ (OAPI patent), BR, CA, CF (OAPI patent), CG (OAPI patent), CH (European patent), CI (OAPI patent), CM (OAPI patent), CS, DE (European patent), DK (European patent), ES (European patent), FI, FR (European patent), GA (OAPI patent), GB (European patent), GN (OAPI patent), GR (European patent), HU, IT (European patent), JP, KP, KR, LK, LU (European patent), MC, MG, ML (OAPI patent), MR (OAPI patent), MW, NL (European patent), NO, PL, RO, SD, SE (European patent), SN (OAPI patent), SU⁺, TD (OAPI patent), TG (OAPI patent), US. Published <i>Without international search report and to be republished upon receipt of that report.</i></p>	

(54) Title: MECHANISM FOR CONTROLLING PRESENTATION OF DISPLAYED PICTURE



(57) Abstract

A digital picture processing system digitizes and stores the digitized photographic film picture (421) in their captured orientation on film, in order to obviate the need to physically rotate the film scanner relative to the film for vertical pictures, thereby significantly reducing the complexity and cost of the scanner. Instead, each stored picture file (421) has an associated presentation control file (422), which contains orientation and aspect ratio information, so that the picture playback device will know how each picture has been stored on the digital picture database, such as a compact disc. When the disc is inserted into a playback device for driving an output display such as a color TV monitor, the playback device is readily able to decode the playback control information in the course of reading out the digitized picture, so that the picture will be displayed in an upright orientation and at the correct aspect ratio for the display.

+ DESIGNATIONS OF "SU"

Any designation of "SU" has effect in the Russian Federation. It is not yet known whether any such designation has effect in other States of the former Soviet Union.

FOR THE PURPOSES OF INFORMATION ONLY

Codes used to identify States party to the PCT on the front pages of pamphlets publishing international applications under the PCT.

AT	Austria	ES	Spain	MG	Madagascar
AU	Australia	FI	Finland	ML	Mali
BB	Barbados	FR	France	MN	Mongolia
BE	Belgium	GA	Gabon	MR	Mauritania
BF	Burkina Faso	GB	United Kingdom	MW	Malawi
BG	Bulgaria	GN	Guinea	NL	Netherlands
BJ	Benin	GR	Greece	NO	Norway
BR	Brazil	HU	Hungary	PL	Poland
CA	Canada	IT	Italy	RO	Romania
CF	Central African Republic	JP	Japan	SD	Sudan
CG	Congo	KP	Democratic People's Republic of Korea	SE	Sweden
CH	Switzerland	KR	Republic of Korea	SN	Senegal
CI	Côte d'Ivoire	LI	Liechtenstein	SU ⁺	Soviet Union
CM	Cameroon	LK	Sri Lanka	TD	Chad
CS	Czechoslovakia	LU	Luxembourg	TG	Togo
DE	Germany	MC	Monaco	US	United States of America
DK	Denmark				

Mechanism for controlling presentation of displayed picture.

The present invention relates in general to digitized picture data processing systems and is particularly directed to a mechanism for controlling the manner in which digitized pictures are to be accessed from a digital database for presentation by a picture playback device.

5

Digital imaging systems, such as those employed for converting still color photographic film (e.g. 35mm) pictures into digital format for storage in a digital database and subsequent playback, as by way of a color television monitor, customarily encode the output of an opto-electronic film scanning device to some prescribed resolution and store the encoded picture in an associated database as a respective picture file. When it is desired to display a particular stored picture, the contents of the respective addresses of the database in which the digitized picture has been stored are read out and coupled to display driver circuitry for energizing corresponding pixels on the TV monitor.

10
15

Because each frame of a typical roll of 35mm film has different horizontal and vertical frame dimensions, for example a dimension of 36mm in the horizontal direction, parallel to the lengthwise direction of the film, and a dimension of 24 mm in the vertical direction, orthogonal to the lengthwise direction of the film (a horizontal:vertical aspect ratio of 3:2), a photographer often rotates the camera ninety degrees about the lens axis in order to capture a subject in what is conventionally referred to as a 'vertical' condition. Since the digitizing mechanism that scans the film strip digitizes each frame as though it contains a 'horizontally shot' picture, then, when a 'vertically shot' picture is displayed, it will be rotated unless the recording and playback system has been designed to accommodate vertical pictures.

20
25

One conventional approach to handle the problem, similar to that described in the U.S. patent to Ohta, No. 4,641,198, is to rotate those film frames which contain vertical pictures by ninety degrees before scanning and to fill in the left and right sides of the picture with a uniform 'border' color (e.g. black) . Although this scanning method will provide the proper orientation of the displayed picture, it suffers from two drawbacks. First, the actual scanning mechanism must be modified to effect a rotated scan of the vertical pictures. This is conventionally accomplished by physically reorienting the film by ninety degrees and changing the lens magnification of the scanning device by an amount related to the frame aspect ratio. Secondly, since side borders, which contain no useful information in terms of the captured picture, are also recorded, some of the information storage capacity of the recording medium is wasted. A second solution to the problem is to rotate the display device, which is obviously impractical in many applications .

A third solution is to allow for different picture orientations to be stored, together with digital control data indicative of the orientations of the pictures, and to employ a picture playback device designed to read the orientation control data to properly orient the pictures on playback. Some conventional computer picture file formats, for example, the Tag Picture File Format (TIFF), Revision 5.0, developed jointly by Aldus Corporation, Seattle, Washington, and Microsoft Corporation, Redmond, Washington, and described in "An Aldus/Microsoft Technical Memorandum, August 8, 1988, include the provision for an optional "tag", which can be used to indicate the orientation of the picture. Page 25 of this document describes the TIFF 'orientation tag', which can have eight different values, indicating whether the zeroth row and zeroth column of the pixel data matrix represents the top and left, top and right, bottom and right, bottom and left, left and top, right and top, right and bottom, or left and bottom of the visual picture, respectively. However, the Aldus document further states that such a field is recommended. for private (noninterchange) use only. The default condition, where the zeroth row represents the visual top of the picture, and the zeroth column of the pixel data matrix represents the visual left hand side of the picture, is recommended for all non-private applications, including those

involving importing and printing. Thus, the TIFF orientation tag is never used to re-orient for display pictures which have been stored in different orientations in a picture database.

5 In addition to the problem of different picture orientations, captured pictures may have different aspect ratios. For example, dedicated use panoramic cameras, such as the Kodak Stretch (TM) camera have an aspect ratio of 3:1 which is considerably wider than the abovereferenced 3:2 aspect ratio of conventional 35mm cameras. Other camera types, such as those which employ 126 type film also have aspect ratios other than 3:2.

10

In accordance with the present invention, advantage is taken of the information storage capability of the database in which the digitized pictures are stored to incorporate an additional presentation control file for each stored picture. This presentation control file contains orientation and aspect ratio
15 information, so that the picture playback device will know how each picture has been stored on the database and will therefore know how to access the stored picture so that it is played back in a proper upright condition.

20 More particularly, the present invention is directed to an improved storage and retrieval mechanism for a digital picture processing system wherein a plurality of photographic pictures that have been captured on a photographic film strip are digitized for processing and subsequent display. The film strip can be expected to include both horizontally-shot (whether upright or inverted) and vertically-shot (in either a right or left hand rotation) pictures. Digitized pictures are stored on a digital data storage recording medium, such as
25 a compact disc, which is capable of being coupled to a picture playback device for reproduction of a digitized picture on a display such as a color TV monitor.

Pursuant to the present invention, rather than cause a relative physical rotation between film strip and the digitizing scanner, each picture on the film strip is scanned and digitized as though it were horizontally oriented,
30 irrespective of its actual orientation on the film. The digitized picture is entered into a frame store and displayed on a display monitor of a system workstation, so that the picture may be viewed by the operator. Using a workstation input device

(e.g. keyboard or mouse) the operator may then enter a set of 'presentation' control codes that are incorporated within a presentation control file associated with a respective picture file. These presentation control codes preferably include a first digital code representative of the orientation in which the picture is
5 currently displayed (corresponding to its orientation as digitized from the film strip) and a second digital code representative of its aspect ratio. Once all control information relative to the picture has been defined, both the digitized picture and its presentation control file are written to a portable storage medium, such as a write once optical disc.

10 Subsequently, when the disc is inserted into a playback device for driving an output display such as a color TV monitor, the playback device decodes the presentation control file information in the course of reading out the digitized picture, and uses the presentation control file to control the playback device in such a way as to display the picture in an upright orientation and at the
15 correct aspect ratio for the display. A border generator fills in non-accessed pixel addresses to complete the picture on the display. In addition to responding to presentation control file orientation and aspect ratio codes, the playback apparatus may respond to user-generated control signals for defining the limits of an auxiliary border to be injected onto the displayed picture, so that cropping of
20 selected portions of a picture may be controlled by the user.

Figures 1a, 1b and 1c show a picture-storage system, a picture retrieval and reproduction system, and a simplified picture retrieval and reproduction system respectively;

25 Figure 2 shows a suitable format for recording picture information on a record carrier;

Figure 3 illustrates a suitable method for digitizing the picture information;

30 Figure 4 illustrates a suitable residual coding to be used for in digitizing picture information;

Figure 5 illustrates a suitable arrangement of the color information of a picture for a series of digitized pictures of increasing

resolutions;

Figure 6 illustrates an example of a picture processing function;

Figure 7 shows an embodiment of a retrieval and reproduction system capable of displaying picture information in accordance with picture parameter data;

Figure 8 shows a suitable format for recording picture parameter data on the record carrier;

Figure 9 shows a suitable format for storing picture parameter data in a non-volatile memory;

Figure 10 shows a mosaic picture composed of sixteen low-resolution pictures;

Figure 11 shows in greater detail an embodiment of the simplified picture retrieval and reproduction system;

Figure 12 shows in greater detail an embodiment of the picture storage system;

Figure 13 shows a recording unit for use in the picture storage system;

Figure 14 diagrammatically illustrates the CD-ROM XA format;

Figure 15 shows a suitable organisation of the record carrier if the picture information has been recorded in accordance with a CD-I format;

Figure 16 shows an example of a picture processing unit;

Figures 17 and 18 illustrate picture processing functions to be performed by the picture processing unit;

Figure 19 shows an embodiment of a read device;

Figure 20 diagrammatically illustrates the use of a sample rate converter in a simplified picture processing unit; and

Figure 21 diagrammatically illustrates a photographic color film processing system in which the present invention may be employed;

Figure 22 diagrammatically illustrates a portion of a film strip that contains a plurality of successive picture frames on each of which a picture of an arrow has been recorded;

Figure 23 shows the format of a header file;

Figure 24 diagrammatically illustrates the signal processing architecture of a picture retrieval mechanism in accordance with the present invention;

5 Figure 25 illustrates the overlay of a rectangular perimeter frame sized to an NTSC TV monitor on a pixel array represented by the contents of the picture memory of Figure 24 for a horizontal normal picture;

10 Figure 26 illustrates a rotated rectangular perimeter frame overlay associated with a decimated sub-array portion of data entries of the picture memory of Figure 24 on an NTSC pixel matrix, where the contents of the picture correspond to a 90° rotated picture that has been slightly demagnified;

15 Figure 27 illustrates the manner in which entire horizontal dimension of a stored 512X768 picture may be displayed on a 484X640 pixel matrix by performing a five-sixths decimation of column and row addresses of a normal or inverted horizontal picture;

Figure 28 illustrates the manner in which address decimation may be employed to display the entire horizontal dimension of a panoramic picture having a 3:1 aspect ratio; and

20 Figure 29 shows a displayed picture having a user-generated auxiliary border.

Figure 1a shows a picture storage system 12 in which the invention can be used. The picture storage system 12 comprises a picture scanning unit 1 for scanning pictures on a photographic picture capture medium 3, for example a 35 mm film strip. The picture scanning device 1 further comprises a picture digitizing unit for digitizing the picture information obtained upon scanning. The digitizing picture information is recorded on a data base medium, e.g. a record carrier 184 by means of a recording unit 5 under control of a control unit 4. Prior to recording the control unit 4 can apply an optional picture processing, for example to enhance, correct or edit the picture representation defined by the digitized picture information. For this purpose the control unit may comprise picture processing means which are known per se.

25
30

The recording unit 5 may comprise, for example, an optical, a magnetic or a magneto-optical recording device. In view of the high storage capacity of optical and magneto-optical record carriers it is preferred to use an optical or a magneto-optical recording device. The control unit 4 may comprise a computer system, for example a so-called "personal computer" or a so-called work station with suitable hardware and application software.

Figure 1b shows a picture retrieval and reproduction system for retrieving and displaying representations of digitized pictures stored on the record carrier 184 by means of the picture storage system 12. The picture retrieval and reproduction system 13 comprises a read unit 6 for locating and reading out selected digitized pictures under control of a control unit 7. Representations of digitized pictures thus read can be made visible on a picture reproduction unit. Such a picture reproduction unit may comprise a display screen 8, which for example forms part of the control unit 7, or an electronic picture printer 9 for generating a hard copy 15 of a representation of the read-out digitized picture. The picture retrieval and reproduction system 13 may further comprise an additional recording device 5a, by means of which the digitized picture information read by means of the read device 6, after an optional picture processing operation performed by the control unit 7 for the purpose of enhancement, correction or editing. The control unit in the picture retrieval and reproduction system 13 may comprise a computer system, for example a "Personal Computer", or a work station with suitable hardware and application software. Although such a system is very suitable for the control task to be performed and the optional picture processing it has the drawback that it is comparatively expensive.

In general, it is desirable to have such an expensive computer system for the control unit in conjunction with the electronic picture printer 9 because of the complexity of the control and picture processing functions. However, if it is merely desired to display selected digitized pictures on a display screen, the computing capacity and storage capacity of a computer system in the form of a personal computer or work station are high in comparison with the control functions to be performed. In that case it is preferred to employ a

simplified control unit with a limited computing and storage capacity and a limited data processing speed. The system as shown comprise a digitized picture playback device, which includes the read unit 6, and a picture processing unit which converts the digitized picture read by the read unit into a picture signal which is suitable for the reproduction unit (display screen 8 or printer 9). This picture processing unit may be comprised partly or completely into the read unit 6, the control unit 7 or the picture reproduction units 8 or 9.

Figure 1c shows a simplified picture retrieval and reproduction system 14. This simplified system 14 comprises a display unit 10 and a picture retrieval and a digitized picture playback device 11 comprising the read unit 6. A control unit for controlling the retrieval and read operation and, if applicable, a limited picture processing can be accommodated in one of the units 10 and 11, but suitably in the unit 11. When the control unit is accommodated in the retrieval and read unit 11 it is possible to employ, amongst others, a standard TV set or monitor unit for the picture display device.

This is an advantage, in particular for consumer uses because the consumer then merely has to purchase the retrieval and read device to display the representations of the pictures.

As a result of their comparatively high cost the picture storage system 12 shown in Fig. 1a and the picture retrieval and reproduction system 13 shown in Fig. 1b are particularly suitable for central uses, for example in photoprocessing laboratories or photofinishing minilab.

For recording digitizing picture information it is preferred to record the information on the record carrier in a predetermined format and order. Figure 2 shows a suitable format and order, in which files containing coded picture information bear the references IP1, ..., IPn. Hereinafter the files IP1, ..., IPn will be referred to as picture files. Moreover, a plurality of control files BB have been recorded. These files contain inter alia read out control data which is used for controlling the read-out of the digitized picture information and picture parameter data, for the purpose of performing optional picture processing operations on the picture information read and for the purpose of displaying representations of the digitized picture information. It is to be noted that the

picture parameter data may be included in the picture files. The advantage of this is that the required picture parameter data becomes available at the instant at which it is needed, *i.e.* at the instant at which the picture file is read.

Apart from the picture files *Ip* and the associated control files *BB*
5 it may be desirable in a number of cases to record files with additional information, for example audio information or text information. Such audio and/or text information may relate to, for example, digitized picture information and can then be reproduced or displayed when the representations of the relevant digitized picture information are displayed. The files with additional information
10 are referenced *ADD* and may be recorded, for example, after the coded picture information.

For every digitized picture stored the picture files contain a plurality of subfiles, which each define a representation of the same scanned picture, the resolutions of the representations defined by these coded pictures
15 being different. In Figure 2 the different subfiles for the picture file *IP1* bear the references *TV/4*, *TV*, *4TV*, *16TV*, *64TV*, *256TV*. The subfile *TV* defines a representation of the scanned picture with a resolution corresponding substantially to a standard NTSC or PAL TV picture. Such a picture may comprise, for example, 512 lines of 768 pixels each. The subfile *TV/4* represents the scanned
20 picture with a resolution which in the horizontal and the vertical direction has been reduced linearly by a factor of 2 relative to the resolution of the picture represented by the subfile *TV*. The subfiles *4TV*, *16TV*, *64TV* and *256 TV* define picture representations whose horizontal and vertical resolution has been increased linearly by a factor of 2, 4, 8 and 16 respectively. Preferably, the
25 subfiles are arranged in such a way that the resolutions of the representations defined by the successive digitized pictures increase (linearly) in steps of 2. During reproduction, when the consecutive subfiles are generally read successively, it is then simple to first display a representation of a picture of low resolution and, subsequently, to replace this representation wholly or partly by
30 representations of the same picture of each time increasing resolution. This has the advantage that the waiting time before a picture representation appears on the display screen is minimized. Indeed, on account of the limited amount of

information needed for this, the read-out time of a digitized picture defining a low-resolution representation is short in comparison with the read-out time of encoded pictures defining higher-resolution representations.

5 A generally known representation of pictures is that in which the picture is composed of a matrix of small areas of constant luminance value and/or constant color value. In this representation it is customary to select the areas of constant color value to be larger than the areas of constant luminance value.

10 An area of constant color value will be referred to hereinafter as a color pixel and an area of constant luminance value will be referred to hereinafter as a luminance pixel. A row of color pixels of a width equal to the full picture width will be referred to hereinafter as a color picture line. A row of luminance pixels of a width equal to the full picture width will be referred to hereinafter as a luminance picture line. A picture represented by luminance
15 picture lines and color picture lines can be defined simply by a digitized picture by assigning to each luminance pixel and color pixel a digital code specifying the relevant luminance value and color values. These digital codes will be referred hereinafter as digitized pixels.

20 Figure 3 by way of illustration shows the structure of a picture of color pixels and luminance pixels. The luminance pixels bear the reference signs $(Y_{2,1}; \dots; Y_{K-1,R-1})$. The color pixels bear the reference signs $(C_{1,1}; \dots; C_{K,R})$. It is to be noted that in Fig. 3, as is customary, the dimensions of the color pixels in the horizontal and the vertical direction is twice as large as the dimensions of the luminance pixels. This means that the resolution of the color
25 information in the horizontal and the vertical direction is a factor of two lower than the resolution of the luminance information.

30 A suitable picture coding is that in which a digital code or digital codes is/are assigned to every luminance pixel and every color pixel, the code(s) defining the absolute value of the luminance component Y and the absolute values of the colour-difference components U and V respectively. Such a coding will be referred to hereinafter as an absolute picture coding. The digitized pictures achieved by absolute picture coding will be referred hereinafter as

absolutely coded pictures. Preferably, representations of a number of low-resolution pictures are recorded as absolutely coded pictures. This enables the picture information to be recovered in a simple manner. This is particularly advantageous for the simplified picture retrieval and reproduction system 14, because this enables the price of such a system, which is intended for the consumer market, to be kept low by the use of simple picture decoding systems.

The use of a picture file with a number of absolutely coded pictures of different resolutions simplifies the reproduction of representations of composite pictures, where a representation of a small low-resolution picture is displayed within the outline of a representation of a higher-resolution picture. The reproduction of such a representation of a composite picture is referred to as "Picture in Picture" ("PIP"). Moreover, recording a plurality of absolutely coded pictures defining representations of the same picture with different resolutions simplifies the reproduction of enlarged representations of details of a digitized picture. Such a function is also referred to as the TELE-function (or ZOOM-function). The availability of absolutely coded pictures with different resolutions implies that for some of the TELE functions and PIP functions the required picture information is directly available and need not be derived by means of additional picture processing operations to be performed by complex circuits.

In the recording of picture information it is customary to record the digitized pixels in rows (or lines) or sometimes in columns. Recording in lines is to be preferred because in the customarily used picture display units the picture information should be presented in the form of lines.

For high resolutions the storage of absolutely coded picture information has the drawback that the amount of information to be recorded is very large. For such high-resolution pictures a residual coding is very suitable. In such a residual coding differences between the signal value of the pixels of the high-resolution picture and the signal value of the corresponding part of the lower-resolution picture are determined and subsequently encoded.

To illustrate this coding method Fig. 4 shows one luminance pixel Y of a low-resolution picture and four luminance pixels $Y_{1,1}'$; $Y_{2,1}'$; $Y_{1,2}'$ and $Y_{2,2}'$ of the corresponding higher-resolution picture in the case that the

horizontal and the vertical resolution is increased by a factor of 2. Instead of the absolute luminance value of the luminance pixels $Y_{1,1}'$, ..., $Y_{2,2}'$ the residual coding encodes differences (hereinafter referred to as residual values) between the luminance values of the luminance pixels $Y_{1,1}'$, ..., $Y_{2,2}'$ and the luminance pixel Y . In this way the residual values of a complete picture can be determined both for the luminance and for the color information. As the number of residual values equal to zero or being very small is large in comparison with the number of large residual values a substantial data compression can be obtained by applying an additional coding in which the residual values are non-linearly quantized and are subsequently subjected to, for example, a Huffman coding. A digitized picture achieved by the above residual coding will be referred hereinafter as residually coded picture.

A residually coded picture can be used as a basis for a new residual coding for a picture with further increased resolutions. Thus, by recording one absolutely coded low-resolution picture and a series of residually coded pictures of increasing resolutions in compressed form it is possible to record a plurality of digitized pictures defining representations of the same picture with increasing resolutions. In the picture file IP1 shown in Fig. 2 the pictures in the subfiles TV/4 and TV are absolutely coded and the pictures in the subfiles 4TV, 16TV, 64TV and 256TV are residually coded, with non-linear quantization and Huffman coding.

The color information is also coded residually in a way similar to the luminance information. However, the horizontal and the vertical resolution of the consecutive residually coded color information increases by a factor of four instead of by a factor of two as with the luminance information. This means that a picture file containing only residually coded luminance information and no color information (4TV and 64TV) alternates with a picture file containing both residually coded luminance information and residually coded color information (16TV and 256TV), see Fig. 2. Leaving out the color information in the subfiles 4TV and 64TV reduces the required storage capacity and the access time to the coded picture information in the picture file. However, the absence of the color information in the subfiles 4TV and 64TV need not adversely affect the picture

quality during reproduction. This is because during the reproduction of a representation of a digitized picture for which no color information has been recorded the color information of the next coded picture defining a representation of higher resolution or the color information of the preceding coded picture defining a representation of lower resolution can be utilised. In order to reduce the total access time to the required picture information it is to be preferred to record the color information U, V in the subfiles 16TV and 256TV contiguously to the luminance information Y in the subfiles 4TV and 64TV, as is illustrated for the file IP* in Fig. 2.

As already stated, it is customary to record the digitized pixels line by line.

The stored digitized pictures generally define a number of pictures with a "horizontal" orientation or landscape format (i.e. for a faithful reproduction the picture should be displayed in an orientation in which the width of the picture is larger than the height of the picture) and a number of pictures with "vertical" orientation or portrait format (i.e. for a faithful reproduction the picture should be displayed in an orientation in which the height of the picture is larger than the width of the picture).

By way of illustration Figure 1 shows a picture capture medium 3 with some pictures in landscape format (2a, 2b, 2c and 2d) and one picture in portrait format (2e). On the record carrier all the digitized pictures are recorded as though they were representations of pictures in landscape format. This is in order to enable a uniform picture scanning to be used without the necessity to detect whether the scanned picture is of the landscape or portrait type and to change over the scanning and/or picture processing depending upon the detection result. However, this means that during reproduction the representations of portrait format pictures will be displayed with an incorrect orientation. This can be precluded by providing a possibility to assign a orientation code to the recorded coded pictures, which code indicates the orientation of the scanned picture. This code can be used to determine whether the representation should be rotated during reproduction and, if this is the case, whether the representation should be rotated through an angle of 90, 180 or 270 degrees. This orientation

code can be included in every picture file IP1, ..., IPn. It is also possible to record these orientation codes in the control file BB or to store these orientation codes in a non-volatile memory arranged in the read unit or connected to this unit.

5 During reproduction it is then possible to determine on the basis of the orientation code whether the representation to be displayed should be rotated and, if this is the case, a rotation through the desired angle can be performed prior to reproduction. A drawback of including the orientation codes in the picture files IP is that these rotation codes have to be determined already
10 during scanning of the pictures. In practice this means that an operator of the picture storage system should determine for each scanned picture whether the stored picture is to be rotated during reproduction, because the known auxiliary devices are not always capable of detecting whether a scanned picture is of
15 landscape or portrait format and whether the picture is presented to the scanning unit with the correct orientation. This is undesirable in particular because it implies that an operator must be present during recording, which makes it difficult to realise a fully automated picture storage system 12.

 If the orientation codes are already available during recording of the digitized picture information it will be advantageous to record these codes on
20 the record carrier. In the case of the file organisation shown in Fig. 2 a suitable position for recording the rotation codes is the subfile FPS of the control file BB. For reasons of user convenience it is desirable to specify, apart from the required rotation, whether instead of a representation of stored coded pictures a
25 representation which is slightly shifted (to the left, right, top or bottom) should be displayed. This is certainly desirable if the display area within which the representation is to be displayed in a display unit is smaller than the dimensions of the representations, because it is possible that an important detail of the picture falls outside the display area. The desired shift can be specified by
30 assigning a translation code to every digitized picture. In Figure 6 a suitable translation coding for a picture 90 is defined by means of the coordinates x_p and y_p of a vertex 91 of the picture 91 to be displayed after translation. By means of a translation code and a magnification code it is possible to specify the

magnification factor with which a certain part of the original picture is to be displayed. The reference numeral 93 indicates an enlarged representation of a part of the picture 90, defined by a translation x_p , y_p and a magnification factor of 2. In addition to the above data it is also possible to include other picture parameter data in the subfile FPS of the control file BB, such as for example

5 parameters specifying a color or luminance adaptation and other picture processing operations to be applied before a representation of the coded picture is displayed. Moreover, it is advantageous to store the desired sequence in which the pictures must be reproduced in the subfile FPS within the control file BB.

10 A collection of picture parameter data defining the preferred sequence as well as all the desired picture parameter data for all the coded pictures on a record carrier will be referred to hereinafter as a set of picture parameter data. It may be advantageous to record more than one set of picture parameters data in the file FPS. This enables a different display sequence and

15 other picture processing operations to be selected by different persons, for example persons within a family. It also allows a user to make a choice from different sets of picture parameter data. It is to be noted that when a record carrier of the write-once type is used the sets of picture parameter data can be recorded on the record carrier only if they are available during recording. This

20 requires human intervention during recording. During reading of the record carrier a set of picture parameter data is selected and the representations of the coded pictures can be displayed in conformity with the selected set of picture parameter data. Figure 10 is a block diagram of an embodiment of a picture retrieval and display system by means of which representations of coded pictures

25 can be displayed in conformity with a selected set of picture parameter data. In this diagram the reference numeral 100 refers to a read unit for reading the record carrier. For the purpose of applying the information being read the read unit 100 is coupled to a control and signal processing unit 101. From the information received from the read device 100 the unit 101 selects the file FPS containing the set(s) of picture parameter data and stores this (these) set(s) in a

30 control memory 102. By means of a data entry unit 103, for example a remote control device, a user can select a set from the control memory 102 and can

subsequently activate the unit 101 to start the read cycle, in which the digitized picture information is read in the sequence specified by the selected set of picture parameter data under control of the unit 101. After the digitized picture information has been read out this information is processed in accordance with the selected set of picture parameter data and is applied to a display unit 104.

It may occur that after some time the picture parameter data stored on the record carrier are no longer entirely in compliance with the user's wishes or that no or incorrect picture parameter data have been recorded on the record carrier. This is problematic in particular if the record carrier is of a type which cannot be overwritten, because the recorded picture parameter data then cannot be adapted. This problem can be mitigated by providing the retrieval and display system in Fig. 7 with a digital data base medium, e.g. a non-volatile memory 105 in which together with a record carrier identification code a new set of picture parameter data or information about the desired changes of the picture parameter data relative to the set of picture parameter data recorded on the record carrier is stored for the record carrier specified by means of the record carrier identification code. In view of the limited storage capacity of the non-volatile memory 105 it is desirable to record the information necessary for the picture parameter data in a most compact form, for which reason it is preferred to record the information about the changes of the picture parameter data.

Fig. 8 shows by way of example a suitable format 110 of the picture parameter data included in the file FPS on the record carrier. The format 110 comprises a section DID in which the unique record carrier identification code is stored. Such a code may comprise a large random number generated by means of a random-number generator and recorded on the record carrier. The code may comprise a time code indicating the time in years, months, days, hours, minutes, seconds and fractions of seconds. Alternatively, the record carrier identification code may comprise a combination of a time code and a random number. In the format 110 the section DID is followed by sections FPS1, FPS2, ..., FPSn in which a number of different sets of picture parameter data are stored. Each of the preferential reproduction setting sections FPS1, ..., FPSn contains a portion SEL in which a set identification number for each of the

different sets of picture parameter data to be selected by different users are specified, and a portion specifying the sequence SEQ in which the representations of the stored pictures are to be reproduced. This portion is followed by the coded sections FIM#1, ..., FIM#n storing for the pictures 1, ..., n the picture parameter data indicating preferential processing operations to be performed before the representation of the relevant picture are displayed.

Fig. 9 shows by way of example a suitable format 120 in which the information about the desired adaptations of the set of picture parameter data can be stored in the non-volatile memory 105. The format 120 comprises a section 121 specifying combinations of record carrier identifications and set identification numbers for which information about picture parameter data has been stored. To each of these combinations a pointer is assigned, which pointer is included in the section DID-POINT and specifies the address of the sections DFPS1, ..., DFPSn in the non-volatile memory 105.

Every section DFPS comprises a portion LSEQ with a code indicating the space (for example in numbers of bytes) required to specify the new sequence. If the portion LSEQ indicates a length not equal to zero LSEQ will be followed by a portion NSEQ with the data specifying the new display sequence. After NSEQ the new preferential processing operations are specified for every picture with modified preferential processing operations. ROT indicates the section with the orientation code. The sections LTELE and LPAN specify the length available for the storage of the new data relating to picture magnification (in a section NTELE) and picture translation (in a section NPAN). In this way it is possible to select the accuracy with which the picture processing information is to be stored. Thus, it is possible, for example, to define three different lengths indicating three different accuracies. LTELE and LPAN are followed by the portions NTELE and NPAN. If the information about the picture magnification and picture translation need not be changed this is indicated by the length zero in LTELE and LPAN. By storing only the preferential processing operations for pictures with modified preferential processing operations the space required for the storage of the new picture parameter data is reduced considerably. Apart from the reduction of the required storage space by said recording of the

differences it is possible to obtain an additional reduction by specifying the length required for the storage of modified data. When the record carrier is read an adapted set of picture parameter data is derived from the picture parameter data recorded on the record carrier and the differences stored in the memory 105, and this adapted set is stored in the memory 102.

Instead of, or in addition to, the fixed non-volatile memory 105 a changeable memory 106, for example in the form of a magnetic card, EPROM, EEPROM or NVRAM, can be employed for the storage of picture parameter data in the retrieval and display system shown in Fig. 7.

This has the advantage that a user can display the picture information on a record carrier in accordance with the same picture parameter data on different picture retrieval and display systems to which a changeable memory 106 can be connected. When one of the two or both memories 105 and 106 are used for the storage of picture parameter data it is desirable that a selection is made from the different sets of picture parameter data defined by the sets of picture parameter data on the record carrier and by the modifications of the picture parameter data stored in the memories 105 and 106. For this purpose the unit 101 should comprise selection means. These selection means may be of a type which are operated by the user to make a choice from the various sets of picture parameter data defined for one specific record carrier and selection number by the picture parameter data information stored on the record carrier and in the memories 105 and 106. However, alternatively these selection means may be of a type which, prior to reproduction on the basis of the contents of the memories 105 and 106 and the sets of picture parameter data recorded on the record carrier, determine the sets of picture parameter data available for the relevant record carriers and store them, for example, in the memory 102. Subsequently, one of the available sets of picture parameter data in the memory 102 is selected in accordance with a predetermined selection criterion. Preferably, the selection criterion is such that the highest priority is assigned to the picture parameter data information in the changeable memory 106, medium priority to the picture parameter data information in the non-volatile memory, and the lowest priority to the picture parameter data on the record carrier. If the

unit 101 comprises a computer, automatic selection can be realised by loading the computer with a suitable selection program.

Now reference is made again to the file OV in Fig. 2, which for all the picture files IP1, ..., IPn comprises a subfile TV/16 containing an absolutely coded low-resolution picture. Recording a file OV has the advantage that an overview of the digitized picture information recorded on the record carrier can be obtained with a minimal access time. This is possible, for example, by successively by displaying the digitized pictures in the subfile TV/16 as representations which wholly or partly fill the display screen, preferably in the sequence defined by the selected set of picture parameter data. However, it is also possible to compose a representation in the form of a so-called mosaic picture from the subfiles, in which mosaic picture a large number of representations of the coded low-resolution pictures contained in the subfiles TV/16 are arranged in the form of a matrix, preferably in an order dictated by the selected set of picture parameter data. By way of illustration Fig. 13 shows a mosaic picture 130 made up of the representations (IM#1, IM#3, ..., IM#26) of sixteen low-resolution subfile pictures.

Fig. 11 shows an embodiment of the picture retrieval and display system of Fig. 1c in more detail. In the present system the picture retrieval and read unit 11 comprises the read unit 6, a control unit 140 and a picture processing unit 141. The read unit 6 supplies the information read from the record carrier to the control unit 140 and to the picture processing unit 141 via a signal path 142. The control unit 140 then selects specific information contained in the control files BB and IIDB from the information read. The picture processing unit 141 selects picture information from the information read and converts this picture information into a form suitable for the display unit 10. The read unit 6 and the picture processing unit 141 are controlled by the control unit 140 on the basis of the data entered by a user, for example via a data entry unit 143, and on the basis of the control data in the control files BB and IIDB.

Fig. 13 shows an embodiment of the picture storage system 12 in greater detail. The scanning unit 1 in Fig. 17 comprises a scanning element 170 for scanning the photographic picture capture medium 3 and for converting the

scanned picture information into customary information signals, for example RGB picture signals, representing the scanned picture. The picture signals at the output of the scanning element define the highest attainable resolution in number of pixels per picture. The information signals supplied by the scanning element

5 170 are converted into a luminance signal Y and two color-difference signals U and V by means of a customary matrix circuit 171. A coding circuit 172 converts the signals Y, U and V in a customary manner into absolutely coded signals (for the lower-resolution pictures) and residually coded signals (for the higher-resolution pictures) in accordance with the coding schemes described

10 hereinbefore. The scanning element 170, the matrix circuit 171 and the coding circuit 172 are controlled by means of a customary control circuit 174 on the basis of control commands applied to the control circuit 174 by the control unit 4 via an interface circuit 175. The absolutely and residually coded picture information generated by the coding circuit 172 is applied to the control unit 4

15 via the interface circuit 175. The control unit 4 may comprise a computer system comprising a display unit 176, a computing and storage unit 177 and a data entry unit 178, for example a keyboard, for data input by the user. In a customary manner the display unit 176 and the data entry unit 178 are coupled to the computing and storage unit 177. The computing and storage unit 177 is further

20 coupled to the picture scanning unit 1 and the recording unit 5 via an interface circuit 179 and 180 respectively. The recording unit 5 comprises a formatting and coding unit 181 which converts the information to be recorded, which information is received from the control unit via an interface circuit 182, into codes which are suitable for recording and which are arranged in a format

25 suitable for recording. The data which has thus been coded and formatted is applied to a write head 183, which records a corresponding information pattern on the record carrier 184. The recording process is controlled by a control circuit 185 on the basis of the control commands received from the control unit 4 and, if applicable, address information indicating the position of the write head 183

30 relative to the record carrier 184.

The storage and control unit 177 is loaded with suitable software to arrange the residually coded digitized picture information supplied by the

scanning unit 1 in a customary manner in accordance with the afore-mentioned formatting rules and to compose the picture files IP and OV. Moreover, the computing and storage unit 177 has been loaded with software for inserting in the control file, in a customary manner and in accordance with the afore-mentioned formatting rules, the picture parameter data input by an operator together with other automatically generated control data, such as for example a list of addresses at which the various files have been recorded on the record carrier 184.

The computing and storage unit 177 may further have picture processing software enabling the scanned picture information to be processed, for example for the purpose of error correction, such as for example out-of-focus correction and grain removal, or for the purpose of color adaptation or brightness adaptation of the picture.

The files composed by means of the computing and storage unit 177 are applied to the recording unit 5 in the desired sequence in order to be recorded.

Very suitable combinations of a record carrier 184 and a recording unit 5 have been described in detail inter alia in European Patent Applications no. 88203019.0 (PHQ 88.001), 90201309.3 (PHQ 89.016), 8900092.8 (PHN 12.398), 8802233.8 (PHN 12.299), 8901206.3 (PHN 12.571), 90201094.1 (PHN 12.925), 90201582.5 (PHN 12.994), 90200687.3 (PHN 13.148), 90201579.1 (PHN 13.243), and Dutch Patent Applications no. 8902358 (PHN 13.088) and 9000327 (PHN 13.242). The record carrier described therein is eminently suited for recording information in accordance with a CD format. A recording device for recording the files on such record carrier is shown diagrammatically in Fig. 18. The shown recording device comprises a formatting circuit 186, which composes the information to be recorded, which has been applied via the interface circuit 182, in accordance with a formatting scheme, for example as customary in the so-called CD-ROM or CD-ROM XA system.

By way of illustration this format is shown broadly in Fig. 14. In accordance with this format the data is arranged in blocks BLCK of a length corresponding to the length of a subcode frame in the CD signal. Each block

BLCK comprises a block synchronizing section SYNC, a header section HEAD containing an address in the form of an absolute time code corresponding to the absolute time code in the subcode portion recorded with the block, and if the CD-ROM XA format is used the block BLCK further comprises a subheader section SUBHEAD containing inter alia a file number and a channel number. In addition, each block BLCK comprises a DATA section containing the information to be recorded. Each block BLCK may also comprise a section EDC&ECC containing redundant information for the purpose of error detection and error corrections. The recording unit 5 shown in Fig. 13 further comprises a CIRC coding circuit 187 for interleaving the information and for adding parity codes for the purpose of error detection and error correction (hereinafter also referred to as error correction codes). The CIRC encoding circuit 187 performs the above-mentioned operations upon the formatted information supplied by the formatting circuit 186. After these operations have been performed the information is applied to an EFM modulator 188, in which the information is given a form which lends itself better for recording on the record carrier. Moreover, the EFM modulator 188 adds subcode information, which includes inter alia an absolute time code as address information in the so-called subcode Q channel.

Fig. 15 shows an organization of the record carrier in the case that the information has been recorded in the track 20 in accordance with the CD format described above. Parts corresponding to the organization shown in Fig. 2 bear the same reference numerals.

The recorded information is preceded by a lead-in section LI (also referred to lead-in track), as customary in the recording of CD signals, and is terminated with a customary lead-out section LO (also referred to as lead-out track).

When the information is recorded in CD format it is preferred to include in the control file BB a section recorded in accordance with the CD-I standard. These sections are the "Disk Label & Directory", referenced DL, and the so-called application programs, referenced AF. This enables the recorded picture information to be displayed by means of a standard CD-I system.

Preferably, a subfile FPS with the sets of picture parameter data is also included in the application program section AF. In addition to the sections DL and AT the control file BB comprises a subfile IT comprising a section CNTR with control data and a section FPS with the sets of picture parameter data. Preferably, the section IT is recorded in a predetermined area, also known as the "pregap" on the record carrier in a section of predetermined length. This is in order to simplify retrieval of the required information by the microcomputer. Further recording in the pregap has to advantage that the format meets the CD-I format requirements. If the section IT is not large enough to accommodate all the control data a part of the control data can be recorded in a section ITC after the file OV. In that case it is preferred to include a pointer in the section IT to specify the starting address of ITC.

Fig. 16 shows the picture processing unit 141 in greater detail. The picture processing unit 141 comprises a first detection circuit 250 for detecting synchronization codes LD and picture line numbers LN indicating the beginning of each residually coded picture line. A second detection circuit 251 serves for detecting the beginning of each subfile in each picture file with a residually coded picture to indicate the beginning of the section IIDB containing the addresses of a number of digitizing picture lines. It is to be noted that the detection circuits 250 and 251 are needed only for processing the residually coded pictures and not for processing absolutely coded pictures. For the purpose of these detections inputs of the first and the second detection circuit 250 and 251 are connected to the signal path 142. A decoding circuit 252 for decoding the residually coded picture information and a control circuit 253 for controlling the picture processing operation are connected to the signal path 142. The signal path 142 and outputs of the decoding circuit 252 are connected to data inputs of a picture memory 255 via a multiplex circuit 254, to store the read and decoded picture information. Data outputs of the picture memory 255 are connected to the inputs of the decoding circuit 252 and to the inputs of the multiplex circuit 254. The control circuit 253 comprises an address generator 256 for addressing the memory locations in the picture memory 255. The picture processing unit 141 further comprises a second address generator 257 for addressing the memory

locations in order to output the content of the picture memory to a signal converter 258. The signal converter 258 is of a customary type which converts the picture information read from the picture memory 255 into a form suitable for application to the picture display unit 10. The decoding circuit 252 may
5 comprise, for example, a Huffman decoding circuit 261a controlled by the control unit 253 and an adder circuit 259. The Huffman decoding circuit 261a decodes the information received via the signal path 142 and subsequently supplies this decoded information to one of the inputs of the adder circuit 259. Another input of the adder circuit 259 is connected to the data outputs of the
10 picture memory 255. The result of the adding operation performed by the adder circuit 259 is applied to the multiplex circuit 254. The control circuit 253 is coupled to the control unit 140 via a control signal path 260. The control circuit 253 may comprise, for example, a programmable control and computing unit. Such a control and computing unit may comprise, for example, a dedicated
15 hardware unit or a microprocessor system loaded with suitable control software, by means of which on the basis of control commands received via the control signal path 260 the address generator 256 and the multiplex circuit 254 are controlled in such a way that a selected portion of the picture information applied via the signal path 142 is loaded into the picture memory. The information thus
20 stored in the picture memory 255 is read with the aid of an address generator 257 and is subsequently applied to the display unit 10 via the signal converter 258 in order to be displayed.

In Fig. 17 the reference numerals 261, 262, 263 denote picture representations of the same picture but with different resolutions. The
25 representation 261 comprises 256 picture lines of 384 pixels each. The representation 262 comprises 512 picture lines of 768 pixels each and the representation 263 comprises 1024 picture lines of 1536 pixels each. The digitized pictures corresponding to the representations 261, 262 and 263 are included in consecutive subfiles TV/4, TV and 4TV of a picture file IP. The
30 capacity of the picture memory 255 shown in Fig. 17 is 512 rows of at least 768 memory locations (also called memory elements). If a representation should represent the entire coded picture that subfile is selected from the picture file IP,

whose number of pixels corresponds to the capacity of the picture memory, which in the present case is the subfile defining the representation 262. This selection can be made on the basis of the setting data, such as picture numbers and resolution order (this is the identification of the subfile resolution), which are
5 stored at the beginning of each subfile in, for example, the header HEAD and the subheader SUBHEAD of the blocks BLCK. For each subfile this data is read in by the control circuit 253 in response to a signal supplied by a block synchronization detector 262a upon detection of the beginning of each block
BLCK.

10 In the case that a representation of an absolutely coded picture is to be reproduced, upon detection of the beginning of the subfile to be selected, the control circuit sets the multiplex circuit 254 to a state in which the signal path 142 is connected to the data inputs of the picture memory 255. Moreover, the address generator 256 is set to a state in which the memory locations are
15 addressed in synchronism with the reception of the successive pixel information, in such a way that the information for the picture lines l1, ..., l512 is stored in the respective rows r1, ..., r512 of the memory 255. The picture information thus loaded into the memory 255 is read out and is converted into a form suitable for the display unit 10 by means of the signal converter 258. The read-out
20 sequence is determined by the sequence in which the address generator 257 generates the successive addresses. During normal reproduction this sequence is such that the memory is read in a row-by-row fashion, starting with the row r1 and starting with column c1 within a row. This is possible both in accordance with the interlaced-scan principle and the progressive-scan principle. In the case
25 of read-out according to the interlaced-scan principle all the odd rows of the picture memory 255 are read first and subsequently all the even rows of the picture memory 255 are read. In the case of read-out in accordance with the progressive-scan principle all the rows are read in sequence.

A very attractive alternative for the method of storing the picture information in
30 the picture memory 255 is that in which the picture memory 255 is first filled with picture information from a picture file defining a lower-resolution representation of a picture and subsequently the content of the memory is

overwritten with a coded picture defining a higher-resolution representation of the same picture. In the above example this is possible in that during read-out of each coded pixel from the subfile TV/4 each of a group of 2x2 memory elements is each time filled with the signal value defined by this coded pixel. This method is known as the "spatial replica" method. A better picture quality is obtained by filling only one of the memory elements of the 2x2 matrix with the signal value defined by a read-out pixel, and by deriving the other pixels of the 2x2 matrix from adjacent pixels by means of known interpolation techniques. This method is known as the "spatial interpolation" method. After detection of the next subfile (in the present case TV) the content of the picture memory is each time overwritten with the picture information of this subfile in the methods described above. The amount of information in the subfile TV/4 is only a quarter of that in the subfile TV. This results in a substantial reduction of the time after which a first provisional picture is displayed on the display unit. After read-out of the picture file TV/4 this low-resolution picture is overwritten with a representation of the same picture having the desired resolution. As the picture files with coded pictures of successive resolutions succeed one another directly no time is lost in searching for the subfile TV after read-out of the subfile TV/4.

In the case that a picture is to be rotated the address generator 256 is set to a state in which the sequence of addressing the memory locations is adapted in accordance with the desired rotation angle. Figs. 18b, 18c and 18d illustrate how the picture information is stored in the memory for a rotation through an angle of 270, 180 and 90 degrees respectively. For the sake of clarity these Figures only show the positions of the information of the first two picture lines 11 and 12 of the picture.

In the case that a representation of a small picture is to be displayed within the outline of a full-scan representation of another picture or, if desired, the same picture (PIP function), this can be achieved simply by filling the desired location of the picture memory 255 with the low-resolution picture of the subfile TV/4 without magnification. When the picture memory 255 is filled the address generator 256 is then set to a state in which the information for memory locations is addressed in which the small picture is to be stored. To

illustrate this these memory locations are represented as a frame 264 in Fig. 17. During the picture processing described above the presence of the low-resolution picture in the subfile TV/4 again has the advantage that the picture information required to perform this function is directly available in the picture file IP, so
5 that additional processing is not necessary.

When an enlarged representation of a part of the absolutely digitized picture is to be displayed the information of a part of the picture, for example the part corresponding to a frame 265, is selected. The information of each pixel of the selected part is loaded into every memory location of a group of
10 2x2 memory locations, so that a magnified full-scan representation of low resolution is displayed on the display unit. Instead of repeating each pixel 2x2 times in the memory the memory may be filled in accordance with the spatial-interpolation principle mentioned in the foregoing.

In order to magnify the residually coded pictures the above step
15 is performed first. Subsequently, the part represented by the frame 266 is selected in the subfile 4TV. The part in the frame 266 corresponds to the part within the frame 265 in the representation 262. The control circuit 253 sets the multiplex circuit 254 to a state in which the output of the residual decoding circuit 252 is connected to the data inputs of the memory 255. The address
20 generator 256 is set to a state in which it addresses the picture memory 255 in synchronism with the received coded pixels in the sequence in which the residually coded digitized picture information from the subfile 4TV becomes available. The picture information in the addressed memory locations is applied to the decoding circuit 252 and by means of the adder circuit 259 it is added to
25 the residual value, after which the information thus adapted is loaded into the addressed memory location. The part of the picture information recorded on the record carrier corresponding to the frame 266 is preferably read on the basis of the information in the control file IIDB. The information in the section IIDB is read in by the control circuit 253 in response to a signal from the detector 250.
30 Subsequently, the address of that digitized picture line is selected from this information which is situated shortly before the first digitized picture line corresponding to the picture line in the frame 266. After this, the control circuit

supplies a command to the control unit 140 via the control signal path 260, which control unit in response to this command initiates a search process in which the part with the selected digitized picture line is located. When this part is found the read-out of the picture information is started and the adaptation of the content of the memory 255 is started as soon as the part of the first digitized picture line which corresponds to the part of the picture within the frame 266 is reached. The detection of this digitized picture line is effected on the basis of the line numbers which together with the line synchronization codes LD have been inserted at the beginning of each digitized picture line. The control circuit reads in these line numbers LN in response to a signal from the detector circuit 251. The storage of the address information at the beginning of the subfile 4TV enables a rapid access to the desired information to be obtained. The detection of the read-out of the desired residually digitized picture lines is simplified by the presence of the line synchronization codes and line numbers in the subfile 4TV.

Fig. 19 shows an embodiment of the read unit 6 by means of which it is possible to read out the coded picture information recorded on the record carrier by means of the recording unit shown in Fig. 13. The shown read unit 6 comprises a customary read head 280 which reads the information patterns on the record carrier 184 by scanning the track 20 and converts the resulting information into corresponding signals. The read unit further comprises a customary positioning unit 284 for moving the read head 280 in a direction transverse to the tracks to a portion of the track 20 specified by a selected address. The movement of the read head 283 is controlled by a control unit 285. The signals converted by the read head 280 are decoded by an EFM decoding circuit 281 and are subsequently applied to a CIRC decoding circuit 282. The CIRC decoding circuit 282 is of a customary type, which restores the original structure of the information which has been interleaved prior to recording and which detects and, if possible, corrects incorrectly read codes. Upon detection of incorrigible errors the CIRC decoding unit supplies a new error flag signal. The information which has been restored and corrected by the CIRC decoding circuit 282 is applied to a deformatting circuit 283 which removes the additional information added by the formatting circuit 186 prior to recording. The EFM

demodulating circuit 281, the CIRC decoding circuit 282, and the deformatting circuit 283 are controlled in a customary manner by the control unit 285. The information supplied by the deformatting circuit 283 is applied via an interface circuit 286. The deformatting circuit may comprise an error correction circuit by
5 means of which errors which cannot be corrected by the CIRC decoding circuit can be detected and corrected. This is effected by means of redundant information EDC & ECC added by the formatting circuit 166. The error correction circuit, which is comparatively complex and therefore comparatively expensive, is not necessary. This is because the effects of erroneously read codes
10 in the absolutely coded picture information can be masked simply by replacing the incorrectly read coded pixels and/or a complete coded picture line by picture information derived from one or more adjacent coded pixels or adjacent coded picture lines. Such a correction can be effected simply by means of the signal processing unit 141 shown in Fig. 16, by programming the control circuit 253 so
15 as to be responsive to the error flag signal supplied by the CIRC decoding circuit 282 to control the address generator 256 in such a way that the information of an adjacent pixel is read and, at the same time, the multiplex circuit 254 is set to a state in which the data outputs of the picture memory 255 are connected to the data inputs. Subsequently, the address generator is reset to its previous state and
20 instead of the incorrectly read coded pixel the information read from the picture memory 255 is stored at the addressed memory location.

In the case that a residually coded picture is read the value in the memory 255 is not adapted upon detection of an incorrectly read residual value but remains unchanged. This can be achieved, for example, by causing the
25 control circuit to generate a signal which inhibits writing into the memory 255 when the erroneous residual value is applied.

The capacity of the picture memory 255 is large, so that the cost price of such a memory is comparatively high. The memory capacity may be reduced by arranging between the multiplexer 254 and the picture memory 255 a
30 sample rate converter 290 of a customary type, which reduces the number of pixels per line from 786 to 512.

With reference to Fig. 21-27 now further embodiments of the

apparatus and method will be described.

Figure 21 diagrammatically illustrates a photographic color film processing system (photofinishing minilab) with which the present invention may be employed.

5 In accordance with the digital picture processing system of Figure 21, photographic pictures, such as a set of twenty-four or thirty-six 36 mm x 24 mm picture frames of a 35 mm film strip 410, are scanned by a high resolution opto-electronic film scanner 412, such as a commercially available Eikonix Model 1435 scanner. High resolution scanner 12 outputs digitally encoded data
10 (e.g. a 3072 x 2048 pixel matrix) representative of the interval electronic scanning of a high resolution picture sensing array onto which a respective photographic picture frame of film strip 10 is projected. This digitally encoded data (digitized picture) is coupled in the form of a pixel array-representative bit map to an attendant picture processing workstation 414 which contains a frame store and picture processing application software through which the digitized
15 picture may be processed (e.g. enlarged, cropped, subjected to a scene balance correction, etc.) to achieve a desired picture appearance. Once a picture file has been prepared, it is stored on a transportable data base medium, such as a write-once optical compact disc, using compact disc recorder 416. The disc may then
20 be inserted into a compact disc player 420 and, via the operation of selector switches of a cabinet-resident control panel or (I) remote control unit 600, a selected picture file is accessed for display on the user's television set 422. The CD player may also drive a high resolution thermal printer 424 for obtaining a hard copy of a selected picture.

25 In accordance with the picture processing system as described hereinbefore each digitized high resolution picture is stored as a respective picture file containing a low, (or base) resolution absolute coded pictures, and a plurality of higher resolution residual coded pictures associated with respectively
30 increasing degrees of picture resolution. By iteratively combining the higher resolution residual digitized pictures data with the low resolution absolute digitized pictures successively increased resolution pictures may be recovered from the base resolution picture.

As an example, spatial data values representative of a high resolution (3072 x 2048) picture scan of a 36 mm -by-24 mm picture frame of a 35 mm film strip 10 may be stored as a respective picture file including a base resolution digitized picture containing data values associated with a spatial picture array of 512 rows and 768 columns of pixels and an associated set of residual coded pictures, to be stored on the disc. Within the workstation itself, the base resolution digitized picture may be further sub-sampled to derive an even lower resolution sub-array of picture values (e.g. on the order of 128 x 192 pixels) for display on a segment of the system operator's workstation for the purpose of identifying picture orientation and specifying aspect ratio. Preferably, a header file is associated with each picture file for the purpose of specifying how the picture was captured on film and has been correspondingly digitized and stored on disc. The information in the header file is used by the playback device to ensure that the picture will have an upright orientation and the correct aspect ratio for the reproduction device. In addition, a master header file is recorded which includes a unique ID number for each disc recorded by CD recorder 416 in figure 21, in order to uniquely identify each disc.

When a film strip is originally scanned in the photoprocessing minilab, each picture is digitized as though it were horizontally oriented, irrespective of its actual orientation on the film. The digitized picture is stored in the workstation's frame store, as is, and a lower resolution representation of the digitized picture is displayed on the display monitor of workstation 14, so that the picture may be viewed by the operator. As each picture is digitized and stored on the disc, the photofinishing minilab operator, using a workstation input device, enters picture parameter data in the form a set of "presentation" control codes that are incorporated within the header file associated with a respective picture file to indicate how the picture has been stored, so that, when subsequently accessed by a reproduction device, the picture will be played back in an upright orientation at the correct aspect ratio.

Figure 22 diagrammatically illustrates the signal processing architecture of a picture retrieval mechanism that has been modified in accordance with the present invention to incorporate an auxiliary removable

memory module for storing user-customized picture parameter data. The playback device itself is preferably compact optical disc player, such as a CD-I player which accesses digital picture files that have been stored on disc and supplies video signals to a user's color television monitor. The contents of the picture file read from an optical compact disc 440 are coupled to a deformatter 442, wherein the file is deformed into a digitized picture and its associated header field, under the control of a resident microcontroller 444. The digitized picture is stored in a picture memory 450, while the contents of the header field are coupled to a memory access control circuit 452, which controls how the digitized picture data is transferred from the disc into picture memory 450 and how the contents of the frame store are read out to associated circuitry 454 for driving a color television display 456. Depending upon the size of picture memory 450, the architecture of the memory access control circuitry may incorporate decimation/interpolation operators to adjust the aspect ratio and size of the picture eventually supplied by the frame store to the television display. In accordance with the improvement provided by the present invention, the user/viewer is able to supply and store customizing picture parameter data independently of preprogrammed picture parameter data on the disc, so that microcontroller 444 will control the presentation of picture data to the display device in accordance with such user-preference inputs. For this purpose, microcontroller 444 is coupled with an interface 458 through which it may write to and read a removably engageable auxiliary digital data base medium, such a memory module 460 e.g. in the form of an electrically erasable programmable read only memory (EEPROM). The form module 460 takes may be any of a variety of currently available EEPROM modules, such as a "smart card" or a magnetic ROM cartridge used in commercial video games and laptop computers. For an illustration of the use and manner of interfacing an EEPROM device, per se, as an auxiliary memory module for augmenting the internal storage capability of a playback device, attention may be directed to the US Patent to Hayes et al, No. 4,855,842, which describes the interfacing of such a module for a programmed video teaching system and how such an auxiliary memory module can be used to permit access by one or more specific users (students) and keep

track of a student's progress.

In accordance with the present invention, such an auxiliary, transportable, memory module is used for storing user-sourced picture parameter data, such as contrast, picture magnification, color balance, saturation, border type and border location, etc., thereby enabling the user to save, in a removable memory module, parameters that have been input to the microcontroller, as by way of a conventional, hand-held remote control (IR) unit 600. Removable memory module 460 may then be extracted from interface 458 in the playback device and reinserted into that device during a subsequent playback operation or inserted, along with its associated disc, in another playback device for controlling another reproduction unit.

In order to facilitate an understanding of the picture customizing and auxiliary storage mechanism of the present invention, the following discussion will explain both the operation and the data structure used to assemble respective pictures and associated parameter fields that are defined in the course of customizing one or a plurality of pictures.

When an optical compact disc onto which digitized picture files have been recorded is inserted into playback device 420 in figure 21, the presentation of picture on NTSC display 422 can be controlled by the user via IR remote control unit 600, which is shown in greater detail in figure 27. Individual pictures can be viewed by entering the picture number using buttons 604 and then pressing the play button 606, or by pressing either the track forward or track backwards arrows 608 to move on to the next or back to the previous picture on the disc. As the picture data is read from the disc 640, the preprogrammed picture parameter data is used to control the memory access control circuit 452, so that the correctly oriented picture is read from picture memory 450. However, should the orientation code in the preprogrammed picture parameter data be in error, due for example to an operator erroneously programming the presentation control data for the particular picture in the course of recording the picture onto the disc via CD recorder 416 (figure 21), then the user may re-orient the picture via rotate buttons 620.

The user may also zoom in or out to display only a portion of the

picture in enlarge form by pressing the zoom button 610 followed by either of the up/down arrow keys 616, which instructs the memory control circuit 452 to read out the proper portion of the picture stored in picture memory 450. Further, the user may alter the appearance of any displayed picture by pressing the
5 "lighten" button 622 followed by either the up/down arrows 616, which cause the supply of control codes for increasing or decreasing the contrast of the picture, respectively, or the left/right arrows 618, which increase or decrease the brightness of the picture, respectively, by properly instructing the color and tone modification circuit 453 to alter the brightness or contrast of the digitized picture
10 as desired, via digital lookup tables.

The user may also alter the color of the displayed picture. For this purpose, the user may depress color button 624, followed by either the up/down arrows 616, which cause the generation of control codes to increase or decrease the color saturation of the picture, respectively. Similarly, the user may
15 depress the left/right arrows 618, which alter the color balance of the picture, respectively, by instructing the color and tone modification circuit 453 to alter the saturation or color balance of the digitized picture by means of a digital 3 x 3 color correction matrix circuit (not shown).

The user may also create a colored border in the picture via color
20 border generator and text generator 455, by first pressing the border button 626 followed by the arrow keys 616 and 618 which allow the border to be properly positioned. The color of the border can be changed by pressing the color button 624 and the border button 626 simultaneously, and then pressing keys 616 to alter the color saturation, or keys 618 to alter the color hue.

25 Generation and positioning of the colored border may be accomplished by means of the border generator circuitry disclosed in co-pending U.S. patent application Serial No. 405,816, filed Sept. 11, 1989, entitled "A digital circuit for creating area dependent special effects" by K.A. Parulski, et al, and the disclosure of which is herein incorporated.

30 Finally, via a color and tone modification circuit of the type described in the above-referenced Parulski et al '816 application for generating "posterized" pictures, the user may also create special effects, by first depressing

the effects button 628 followed by the error keys 616 and 618, which cycle through a number of available effects, including posterized, false-color, or "negative" pictures, until the user selects a pleasing effect for the current picture. The ease with which the user may access the above-described features may be facilitated by judicious use of on-screen menu overlays supplied by text generator 955. Once picture has been "customized" in the manner described above, it is very desirable for the user to be able to display the picture in the future in exactly the same fashion, instead of having to repeat the customization procedure each time the picture is to be replayed. Thus, it is advantageous to be able to store the data describing the parameters which indicate how the picture has been altered, so that it can be recalled and used subsequently, when the user wishes to display the same picture. Because the system of figure 21 uses a write-once optical disc, and because CD player 620 cannot record information onto the optical disc, it is not possible to store this data onto the compact disc 640 of figure 22.

Thus, some other method of storing the data is required. While a control data memory may be permanently housed within the CD player, it is preferable that the storage device, such as EEPROM module 460 in figure 22, be removable and insertable into one or more other playback units.

In accordance with the present invention, once the user has customized picture in the manner described previously, the store button 630 is depressed, which causes the parameters which define the manner in which the picture has been altered to be temporarily stored in a scratchpad RAM 445. The user may then proceed display, and optionally alter, any or all of the pictures on the disc, depressing the store button 630 once a preferred picture display is obtained. After all viewing, altering, and storing of pictures on the disc has been completed, the eject button 640 is pressed, which causes the disc to be ejected from the CD player, and also causes data stored in scratchpad RAM 445 to be written into EEPROM memory 460. As a result, the next time the same disc is inserted into any player containing the EEPROM module 460 used during the programming session just described, the customized control data can be read out from EEPROM module 460 into the scratchpad 445, in order to display the

pictures in the order programmed earlier and with the same zoom position, color balance, etc.

The user may delete any of the programmed pictures by pressing the clear button 632, so that any new pictures may be customized by advancing to the desired picture optionally altering the appearance of the displayed picture, and then pressing the store button 630. This new control data is again temporarily stored in scratchpad RAM 445 and then written to removable EEPROM module 660 when the disc is ejected, as described above.

Figure 23 illustrates the organization of the data stored in EEPROM module 660 for the storage of parameters which control picture customization as described above. For purposes of providing an illustrative example, the memory organization of figure 23 assumes that EEPROM module 460 is a 64K byte memory, which corresponds to a 16 bit address space. The 64K memory is divided into four separate sections, a pointer table section 520, a video display control data section 540, an optional reprint request data section 560, and an optional album disc data section 580. The lowest addresses are used to store a pointer table 520 which stores a multiplicity of pointer entries of three different types: disc identification (ID) pointer entries, such as disc #1 pointer entry 502 and disc #n pointer entry 560, print request pointer entries, such as print request pointer entry 510, and album disc request pointer entries, such as album disc request pointer 514.

The disc ID pointer entries, such as disc #1 pointer entry 502, are 6 bytes in length and include 2 values, a 4 byte disc ID number, such as disc #1 ID 503, followed by a 2 byte address value, such as disc #1 address 504. Address 504 is the address within EEPROM address space 500 at which the data for the disc having an ID number matching the value stored in location 503 is stored. In other words, the address 504 "points" (as depicted by line 504) to the EEPROM memory location at which the picture parameter data for pictures with disc #1 ID 503 are stored. Similarly, address 508 at which the data for the disc #N having an ID number matching the value stored in location 507 is stored. The pointer table 520 contains disc ID pointer entries for all discs which have been previously inserted into playback device 420 and programmed in a manner to be

described below.

When a disc is inserted into a CD player 420, the four byte ID number programmed into the header of each disc is read from the disc 440 (figure 2) and the ID number is routed by deformatter 442 to microcontroller 444. Microcontroller 444 then searches the pointer table 520 to determine if any of the disc IDs, for example the IDs stored in location 503 or 507, match the ID number of the disc 540. If there is a match, for example with the ID value stored in location 507 of EEPROM address spaced 500, the corresponding picture parameter data (video control data) in this exemplified disc #N data file 518, is read from EEPROM module 460 into scratchpad RAM 445 via memory module interface 58 and microcontroller 444.

The data in each of the individual disc data files, for example disc #N data file 548, is organized in the manner shown in figure 24. The data file 700 is composed of a number of display records, for example display records 720, 760 and 780. Each display record, for example display record 720, is composed of two parts, a required part 722 including a status byte 730 and a picture number byte 732, and an optional part 724 which depends on the value of status byte 730. The picture byte 732 indicates which picture data record on the disc should be used to create the picture. This allows the pictures on the disc to be played back in any order, and further allows the same picture to be displayed more than once, in two or more different altered forms, so that, for example, different parts of the same picture can be viewed at differing magnifications.

The two LSBs (bit 0 and bit 1) of the status byte 330 are used to stored the orientation of the picture. The next 5 bits (bits 2-6) of status byte 730 indicate which, if any, optional features have been used to alter the picture. In particular, bit 2=1 indicates that the zoom feature was used. When bit 2=1, three one byte parameter values are stored following the picture number byte, the first byte 734 indicating the zoom value (magnification), the second byte 736 indicating the relative position of the left edge of the zoomed area in the x direction relative to the left edge of the original picture, and the third byte 338 indicating the relative position of the top edge of the zoomed area in the y

direction relative to the top edge of the original picture. If, on the other hand, bit 2=0, the zoom feature was not used to alter the picture, and the three one byte parameter values are not stored, thus reducing the memory required.

5 In a similar manner, bit 3=1 indicates that the contrast byte 740 and the brightness byte 742 are present, while bit 3=0 indicates that this feature was not used to alter the picture. Color changes are indicated with bit 4=1 along with saturation byte 744 and hue value byte 746. Bit 5=1 indicates that the border feature was used and that border color byte 748, border X position 750, and border Y position 752 are present. Bit 6=1 indicates that the effects feature
10 was also used, and that the effects byte 754 will be present.

Note that for display recorder 370, on the other hand, none of the optional features was used to alter the appearance of the picture, except perhaps the orientation feature. Status bits 2-7 all are set to 0, indicating that the picture number stored in EEPROM address 772 should be displayed with the
15 default settings for zoom, light, color, and border, and without special effects. For display record 780, only the "lighten" 622 button was used to alter the appearance of the picture, so that bit 3=1, and the contrast and brightness parameters are stored. Record 790, where bit 7=1, indicates that the end of disc data file 700 has been reached.

20 The removable EEPROM module 460 shown in figure 26 can also be programmed to order one or more reprints from a photofinisher equipped with the thermal printer 424 and CD player 420 (figure 1) which incorporates the memory module interface 458 of figure 22. The disc or discs containing the digitized picture, together with EEPROM module 460, are delivered to the
25 photofinisher, who can automatically generate the desired pictures in their desired form, by reading the reprint request data 560 (figure 23).

The organization of file 560 is shown in greater detail in figure 25. File 560 contains a number of print recorders, for example 810 and 820, each of which is composed of four values, a four byte disc number 812, a one
30 byte picture number 814, a one byte print size parameter 816, and a one byte copies value 818. The user programs the reprint request data file 800 by locating a desired picture and pressing the reprint button 620 of remote control unit 600.

The user uses next pusher up/down arrow button 616 to select the desired print size, enters the number of copies desired using buttons 604, and finally pushes the store button 630. After all the desired picture prints have been selected and stored, the disc is ejected and the reprint request data is written from scratchpad RAM 445 to EEPROM module 460, followed by the "reserved word" disc number=0, indicating the end of the reprint request data. When the EEPROM module and discs are supplied to the photofinisher, the reprint request data file may be used to automatically determine the size and number of reprints, and the disc data file used to automatically select any optional features such as zoom, color balance, effects, etc. stored by the user.

The removable EEPROM module 660 in figure 26 can also be programmed to produce one or more "album" picture discs from a photofinisher equipped with the CD recorder 16 and playback device 420 of figure 21, which incorporates a memory module interface 458 of figure 22. The disc or discs containing the digitized pictures, and the EEPROM module 60 are supplied to the photofinisher, who may automatically record the desired pictures in the desired order onto the new album disc, by reading the album disc data 580 in figure 23.

The organization of file 580 is also shown in greater detail in figure 15. File 580 file contains a number of album order records, for example 910, 920 and 930, each of which is composed of two values, a four byte disc number 912, and a one byte picture number 914. The user programs the album disc data file 800 by locating the desired pictures, one at a time and in the desired order, and pressing the album button 660 followed by the stored button 630 on remote control unit 200. When the EEPROM module and discs are given to the photofinisher, the album disc data file is used to automatically decide the order of transferred pictures, and the appropriate disc data files are also written into the master header file of the new album disc, where they may be used to automatically present the pictures on the album disc using the desired optional features such as zoom, color balance, effects, etc., originally stored by the user in the disc data files of the EEPROM module.

As will be appreciated from the foregoing description, the limited ability of an interval memory in a CD player to store user-generated picture

parameter data is augmented in accordance with the present embodiment of the invention by incorporating a storage medium, such as an electrically programmable read only memory module, configured to be removably interfaced with the CD player's microcontroller for storing picture parameter data that has
5 been (remotely) programmed by the user. The module can be then removed from the playback device and inserted into that or another playback device for controlling its operation. The customized picture parameter data may include one or more picture reproduction parameters including contrast, picture magnification, color balance, saturation, border type and border location. It may
10 also store information from which a photofinisher may produce hard copy prints of selected pictures or an entirely new album disc of user selections taken from multiple discs. When creating a new album disc, the customized picture parameter data may be recorded from the memory module into the master header file on the new discs, so that the EEPROM module containing the customized
15 picture parameter data does not need to be replicated.

While we have shown and described an embodiment in accordance with the present invention, it is to be understood that the same is not limited thereto but is susceptible to numerous changes and modifications as known to a person skilled in the art, and we therefore do not wish to be limited
20 to the details shown and described herein but intend to cover all such changes and modifications as are obvious to one of ordinary skill in the art.

Figure 21 diagrammatically illustrates a photographic color film processing system in which the present invention may be employed. However it is to be noted that the application of the invention is not limited to this system,
25 but may be incorporated in any digitized picture processing system.

In accordance with the digital picture processing system of Figure 21, photographic pictures, such as a set of twenty-four or thirty-six 36mmX24mm picture frames of a 35mm film strip 410, are scanned by a high resolution optoelectronic film scanner 412, such as a commercially available
30 Eikonix Model 1435 scanner. Scanner 412 outputs digitally encoded data (e.g. a 3072X2048 pixel matrix) representative of the internal electronic scanning of a high resolution picture sensing array onto which a respective photographic

picture frame of film strip 410 is projected. This digitally encoded data, or 'digitized' picture, is coupled in the form of an imaging pixel array-- representative bit map to an attendant picture processing workstation 414, which contains a frame store and picture processing application software through which the digitized picture may be processed (e.g. enlarged, rotated, cropped, subjected to scene balance correction, etc.) to achieve a desired picture appearance. Once a picture file has been prepared, it is stored on a transportable medium, such as a write-once optical compact disc, using an optical compact disc recorder 416, for subsequent playback by a disc player 420, which allows the picture to be displayed, for example, on a relatively moderate resolution consumer television set 422 (e.g. having an NTSC display containing an array of 485 lines by 640 pixels per line), or printed as a finished color print, using a high resolution thermal color printer 424.

As described hereinbefore in this application each high resolution captured picture is stored as a respective picture file containing sub-files with a low, or base, resolution absolute coded picture bit TV, an absolute coded picture 4TV and a plurality of higher resolution residual coded pictures 16TV, 64TV and 256TV associated with respectively increasing degrees of picture resolution. By iteratively combining the higher resolution residual picture file data with the base resolution bit map picture, successively increased resolution pictures may be recovered from the base resolution absolute coded picture for application to a reproduction device, such as a color monitor display or hard copy printer.

The digitized pictures TV, 4TV, 16TV, 64TV and 256TV may be obtained by scanning a 36mm-by-24mm picture frame of 35mm film strip 410. The base resolution absolute coded picture may be further subsampled in a workstation of the photo-finishing minilab system to derive an even lower resolution absolute code picture TV/4 (e.g. on the order of 128X192 pixels) for display on a segment of the system operator's workstation for the purpose of identifying picture orientation and specifying aspect ratio.

As pointed out above, the present invention takes advantage of the information storage capability of the compact disc to incorporate, within a header file associated with each digitized picture, additional presentation control

files for each stored picture for the purpose of specifying how the picture was captured on film and has been correspondingly digitized and stored on disc, so that, when played back, the picture will have an upright orientation and the correct aspect ratio for the display device.

5 Figure 22 diagrammatically illustrates a portion of the film strip 410 that contains a plurality of successive picture frames 421...425, on each of which a picture of an arrow 430 has been recorded. In frame 421 the arrow has been recorded with the camera held by the photographer in its normal horizontal position. In frame 422 the arrow has been recorded with the camera held by the
10 photographer in its normal vertical position, rotated counter-clockwise 90° relative to its normal horizontal position. In frame 423 the arrow has been recorded with the camera held by the photographer in its flipped or inverted horizontal vertical position, rotated 180° relative to its normal horizontal position. In frame 424 the arrow has been recorded with the camera held by the
15 photographer in its flipped vertical position, rotated clockwise 90° relative to its normal horizontal position. In frame 425 the arrow has been recorded with the camera held by the photographer in its normal vertical position.

 While not every strip of film will necessarily contain pictures at each of the orientations shown in Figure 22, a typical film strip can be expected
20 to include both horizontally-shot (whether upright or inverted) and vertically-shot (either right or left hand rotation) pictures. In accordance with the present invention, rather than physically rotate either the film strip or the digitizing scanner, each picture on the film strip is scanned and digitized as though it were horizontally oriented, irrespective of its actual orientation on the film. The
25 digitized picture is then stored in the workstation's frame store, as is, and a lower resolution version of the digitized picture is then displayed on the display monitor of workstation 414, so that the picture may be viewed by the operator. Then, as each picture is digitized and stored, the system operator, using a workstation input device (e.g. a keyboard or mouse) enters a set of 'presentation'
30 control codes that are incorporated within a presentation control file associated with each respective picture file.

 The format of a presentation control file, such as header file

422H associated with picture data file 422D, into which normal vertical picture frame 422 on film strip 410 has been digitized by scanner 412, is shown in Figure 23 as comprising an M-bit orientation field 431, and N-bit aspect ratio field 433 and a supplemental field 435, in which additional information, such as title, date, etc. may be inserted by the operator in the course of formatting a digitized picture for storage on the disc. For the four possible picture orientations described above and depicted in Figure 22, M=2 bits are required for the orientation field 431. The code width of aspect ratio field 433 depends upon the number of allowable picture aspect ratios; providing a three bit code width will accommodate up to eight different aspect ratios. It should be observed that the parameters and field formats given here are merely for purposes of illustration and are not to be considered limitative of the invention. As in any data processing application what is required is that the actual coding structure and data format of the header field be capable of being read and interpreted by the underlying control mechanism in the reproduction device. Rather than describe the coding details of that mechanism, the description to follow will set forth the architecture of the storage and retrieval mechanism and the manner in which it processes pictures having a variety of orientations and aspect ratios.

Figure 24 diagrammatically illustrates the signal processing architecture of a picture retrieval mechanism in accordance with the present invention, which may be incorporated in a commercially available digital data storage and retrieval device, such as a compact disc player, for supplying video signals to an associated display device, such as a color television monitor. As shown in the figure, data read from a disc 440 is coupled over input bus 441 to a deformatter 442, which separates the control data (the header field) from the (512X768) data. The header data is coupled over link 444 to a memory controller 446, while the picture data is coupled over link 448 to a random access memory 450 the storage capacity of which corresponds to the size of the base resolution picture (512X768 pixels) stored on the disc.

Memory read out controller 446 may be incorporated as part of the CD player's microcontroller or may be a separate dedicated combinational logic circuit driven by the microcontroller for controlling the generation of read

out address/clock signals which are supplied over respective address bus links 452 and 454 to a set of associated column and address counters 456 and 458, respectively, for controlling the rate and order in which contents of memory 450 are accessed.

5 In particular, the "clock" signal lines allow counters 456 and 458 to be incremented (when the up/down signal is asserted) or decremented (when the up/down signal is not asserted), the "preset value" lines allow the counters to be preset to the value indicated by these lines, and the "3:2 decimate" line
10 instructs the counters to skip over every third value (i.e. to provide addresses 0, 1, 3, 4, 6, 7, 9, 10, etc.) and the "6:5 decimate" line instructs the counters to skip every sixth value (i.e. to provide addresses 0, 1, 2, 3, 4, 6, 7, 8, 9, 10, 12, 13, etc.).

 As pointed out previously, each field of picture data for a
15 respective digitized picture is formatted as though the picture is a normal horizontal picture and when downloaded from the disc into memory 450, the picture data is simply written directly into memory 450 in this format. The
20 manner in which the picture is read out from memory 450 in accordance with the contents of its associated header determines the orientation and display of the picture on an associated display device (TV monitor). When picture data is read
25 out from memory 450, it is coupled over link 460 to a border generator 462 which controllably substitutes for the pixel code values accessed from memory 450 an alternate code value, representative of a prescribed border color (e.g. black). For this purpose, border generator 462 preferably comprises a
30 multiplexer switch 463 which connects the digital-to-analog converter 470 to either receive the pixel code data values from memory 450, or to instead receive a "border" code value representing a prescribed border color. The position of multiplexer switch 463 is controlled by the control signal on link 464 from memory controller 446. In this way, border generator 462 selectively injects 'border' pixel values, as instructed by memory controller 446, which fills in border regions of the 512X768 picture array, for the picture files where the aspect ratio code within the header field specifies that the size and shape of the picture being read out from memory should occupy less than the entirety of the

display. The resulting combined picture and border data is then output to digital-to-analog converter 470 for application to a display device, such as a color TV monitor, so that a reproduction of the original 35mm picture will be presented to the viewer.

5 Because conventional television monitors customarily employ a display screen having a 4:3 aspect ratio (and having 484 lines for an NTSC system), then, irrespective of the orientation of the 3:2 aspect ratio picture stored in memory 450, the accessing of memory 450 will require some degree of cropping or decimation of the contents of the 512X768 array. The manner in
10 which memory controller 446 controls the generation of address signals and clocks out the contents of memory 450 for a number of respectively different picture types for the example of an NTSC system television monitor is illustrated in Figures 25-29.

 More particularly, Figure 25 illustrates the overlay of a
15 rectangular perimeter frame 480, the size and shape of which effectively correspond to a 484 row by 640 column pixel array that substantially matches the 484X640 "square pixel" display capacity of an NTSC TV monitor, 'centered', on a 512X768 pixel array represented by the contents of memory 450 for a horizontal normal picture, where the contents of the picture. correspond to an
20 'upright' picture. Since, for either an upright (normal) or inverted horizontal picture, the size of the stored picture exceeds the size of the NTSC display matrix, memory controller 446 confines its column and row output addresses to a set of boundaries that encompasses a 484X640 sub-matrix of addresses centered in frame 480 within memory array 450.

25 In particular, frame 480 encompasses those pixels of the 512X768 pixel array bounded by addresses $Y=13, X=63; Y=13, X=702; Y=496, X=702$, where "Y" is the row address and "X" is the columns address. Those data entries of memory 450 that fall outside of frame 480 are not accessed for display and the associated 484X640 NTSC display will display a normal
30 horizontal picture of the pixels bounded by frame 480. For an inverted horizontal picture the same 484X640 frame of addresses is accessed except that the order of read-out of the successive 484 lines is reversed from that of a normal horizontal

picture. For the inverted horizontal picture, the pixel code value stored at address
Y=496, X=63 is the first (upper left) pixel of the video frame read from
memory 450, whereas pRGB picture signals, representing the scanned picture.
The picture signals at the output of the scanning element define the highest
5 attainable resolution in number of pixels per picture. The information signals
supplied by the scanning element 170 are converted into a luminance signal Y
and two color-difference signals U and V by means of a customary matrix circuit
171. A coding circuit 172 converts the signals Y, U and V in a customary
manner into absolutely coded signals (for the lower-resolution pictures) and
10 residually coded pictures (for the higher-resolution pictures) in accordance with
the coding schemes described hereinbefore. The scanning element 170, the
matrix circuit 171 and the coding circuit 172 are controlled by means of a
customary control circuit 174 on the basis of control commands applied to the
control circuit 174 by the control unit 4 via an interface circuit 175. The
15 absolutely and residually coded picture information generated by the coding
circuit 172 is applied to the control unit 4 via the interface circuit 175. The
control unit 4 may comprise a computer system comprising a display unit 176, a
computing and storage unit 177 and a data entry unit 178, for example a
keyboard, for data input by the user. In a customary manner the display unit 176
20 and the data entry unit 178 are coupled to the computing and storage unit 177.
The computing and storage unit 177 is further coupled to the picture scanning
unit 1 and the recording unit 5 via an interface circuit 179 and 180 respectively.
The recording unit 5 comprises a formatting and coding unit 181 which converts
the information to be recorded, which information is received from the control
25 unit via an interface circuit 182, into codes which are suitable for recording and
which are arranged in a format suitable for recording. The data which has thus
been coded and formatted is applied to a write head 183, which records a
corresponding information pattern on the record carrier 184. The recording
process is controlled by a control circuit 185 on the basis of the control
30 commands received from the control unit 4 and, if applicable, address
information indicating the position of the write head 183 relative to the record
carrier 184.

The storage and control unit 177 is loaded with suitable software to arrange the residually coded picture information supplied by the scanning unit 1 in a customary manner in accordance with the afore-mentioned formatting rules and to compose the picture files IP and OV. Moreover, the computing and storage unit 177 has been loaded with software for inserting in the control file, in a customary manner and in accordance with the afore-mentioned formatting rules, the preferential reproduction settings input by an operator together with other automatically generated control data, such as for example a list of addresses at which the various files have been recorded on the record carrier 184.

The computing and storage unit 177 may further have picture processing software enabling the scanned picture information to be processed, for example for the purpose of error correction, such as for example out-of-focus correction and grain removal, or for the purpose of color adaptation or brightness adaptation of the picture.

The files composed by means of the computing and storage unit 177 are applied to the recording unit 5 in the desired sequence in order to be recorded.

Very suitable combinations of a record carrier 184 and a recording unit 5 have been described in detail inter alia in European Patent Applications no. 88203019.0 (PHQ 88.001), 90201309.3 (PHQ 89.016), 8900092.8 (PHN 12.398), 8802233.8 (PHN 12.299), 8901206.3 (PHN 12.571), 90201094.1 (PHN 12.925), 90201582.5 (PHN 12.994), 90200687.3 (PHN 13.148), 90201579.1 (PHN 13.243), and Dutch Patent Applications no. 8902358 (PHN 13.088) and 9000327 (PHN 13.242). The record carrier described therein is eminently suited for recording information in accordance with the following sequence: Y=1, X=746; Y=3, X=746; Y=4, X=746; Y=6, X=746; ... Y=511, X=746; Y=0, X=743; ... Y=0, X=740; ... for field one and Y=0, X=745; ... Y=0, X=742; ... Y=0, X=739 for field two. For "flipped vertical" pictures, pixel Y=0, X=20 of memory 50 is read out first.

Figure 27 illustrates the manner in which the entire horizontal dimension of the stored 512X768 picture may be displayed using a 484X640

pixel matrix display by performing a "six-to-five" decimation of column and row addresses of a normal or inverted horizontal picture. Namely, memory controller 446 instructs column counter 456 and row counter 458 to provide column and row output addresses such that every sixth pixel and every sixth line is excluded, thereby performing a 5/6 demagnification of the full horizontal picture to a 427X640 pixel sub-array. Again, in the case of an inverted horizontal picture, the same 427X640 frame of addresses is accessed except that the order of read-out of the successive 427 lines is reversed from that of a normal horizontal picture. Also, because of the decimation of the picture, the top and bottom of the picture are delimited by border regions 501 and 502 for which no data is accessed from memory 450. Therefore, upon read-out of the picture data from memory 450, border generator 462 supplements the 427X640 sub-array of pixel values read out from memory 450 with border color representative (e.g. black) pixel values to fill in regions 501 and 502 of the displayed picture.

Figure 28 illustrates the manner in which address decimation, similar to that employed for the picture of Figure 27, may be employed to automatically display the entire horizontal dimension of a panoramic picture, such as one having a 3:1 aspect ratio, as indicated by the aspect ratio code 33=001 in Figure 23. Here read-out of the stored picture involves the same "six-to-five" decimation of the column and row addresses of memory 450, described above with reference to Figure 27. Because of the 3:1 panoramic aspect ratio of the picture, however, only the middle 256 rows of picture data stored in memory 450 contain useful picture data. When reading out the panoramic picture from memory, using "six-to-five" decimation, border generator 462 supplements the 213X640 sub-array of pixel values read out from memory 450 with border color representative (e.f. black) pixel values to fill in regions 511 and 512 of the displayed picture. The aspect ratio code 433 shown in Figure 23 can also be utilized when making a thermal print via printer 424 in Figure 21. In the case of a panoramic 3:1 aspect ratio picture, the printer can recognize that only the middle half of the rows of the 3:2 aspect ratio stored data file contain useful picture data. The top and bottom rows of the stored data file will not be printed by thermal printer 424, thus conserving expensive print media, or allowing two

3:1 aspect ratio pictures to be printed next to one another in the same space normally used to print a single 3:2 aspect ratio picture.

In addition to responding to control data from deformatter 442
5 based upon header orientation and aspect ratio codes, memory controller 446
may be coupled to respond to user-generated control signals for defining the
limits of an auxiliary border to be injected onto the picture output by border
generator 462 via line 464, so that further cropping of selected portions of a
picture may be directed by the user, as shown by border regions 521, 522, 523
10 and 524 in Figure 29 in order to alter the aspect ratio of the displayed picture to
provide a more pleasing composition.

One scheme for controlling an auxiliary border is described in
co-pending U.S. patent application Serial No. 405,816, filed Sept. 11, 1989, by
R. A. Parulski et al, entitled "A Digital Circuit for Creating Area Dependent
15 Video Special Effects", and the disclosure of which is incorporated herein. In
Figure 24 of that application, a "window 1A" signal 520 may be used to drive
signal line 464 of Figure 24 of the present invention to create the auxiliary
border of Figure 29.

As will be appreciated from the foregoing description, by
20 digitizing and storing film pictures in the manner they have been captured on
film, the present invention is able to obviate the need to physically rotate the film
scanner relative to the film for vertical pictures, thereby significantly reducing
the complexity and cost of the scanner and simplifying the storage mechanism.
Instead, the invention takes advantage of the information storage capability of the
25 compact disc database and incorporates an additional presentation control file, so
that pictures can be digitized and stored 'as is' . Since the presentation control
file contains orientation and aspect ratio information, the picture playback device
will know how each picture has been stored in the database. Subsequently, when
the disc is inserted into a playback device for driving an output display such as a
30 color TV monitor, the playback device is readily able to decode the header
information in the course of reading out the digitized picture, so that the picture
will be displayed in an upright orientation and at the correct aspect ratio for the

display.

While we have shown and described an embodiment in accordance with the present invention, it is to be understood that the same is not limited thereto but is susceptible to numerous changes and modifications as known to a person skilled in the art, and we therefore do not wish to be limited to the details shown and described herein but intend to cover all such changes and modifications as are obvious to one of ordinary skill in the art.

CLAIMS:

1. For use with a digital picture processing system in which pictures are digitized by an opto-electronic device for storage in a digital database, a method of storing said digitized pictures comprising the steps of:
 - 5 (a) storing in said digital database respective data files associated with each of said digitized pictures; and
 - (b) for each of said respective data files, storing a presentation control file the contents of which represent the manner in which its associated digitized picture has been digitized by said opto-electronic device.
- 10 2. A method according to claim 1, wherein step (b) comprises storing, within a respective presentation control file, first data representative of the orientation of its associated picture as stored by digital database.
3. A method according to claim 2, wherein step (b) comprises storing, within a respective presentation control file, second data representative of the aspect ratio of its associated picture.
- 15 4. A method according to claim 1, wherein step (b) comprises storing, within a respective presentation control file, data representative of the aspect ratio of its associated picture.
5. A method according to claim 1, further including the step of:
 - 20 (c) reading out from said database data representative of a digitized picture stored in step (a) in a manner that depends upon the contents of its associated presentation control file stored in step (b) and coupling the read out data to a picture reproduction device such that the reproduced picture is reproduced by said picture reproduction device in an upright orientation.
- 25 6. A method according to claim 5, wherein said picture reproduction device comprises a television display.
7. A method according to claim 6, wherein said television display displays a picture at a resolution which is different from the resolution of a

digitized picture stored in step (a).

8. A method according to claim 5, wherein step (c) comprises controllably generating border picture signals representative of picture characteristics of at least one border region to be combined with read out
5 digitized picture data and coupling said border picture signals to said reproduction device, so that the picture reproduced thereby is bound by said at least one border region.

9. A method according to claim 8, wherein step (c) comprises controllably generating said border picture signals according to the contents of
10 said presentation control file.

10. A method according to claim 8, wherein step (c) comprises controllably generating border picture signals exclusive of the contents of said presentation control file.

11. For use with a digital picture processing system wherein a
15 plurality of pictures that have been captured on a photographic recording medium and may include horizontally and vertically oriented pictures, are digitized into respective digital picture data files, each digital picture data file containing data values associated with an array of M by N pixels corresponding to a prescribed resolution representation of a respective one of said plurality of pictures, a
20 method of controlling the manner in which said digital picture data files may be accessed for presentation to a reproduction device, so that a reproduced picture may be viewed in an upright orientation comprising the steps of:

(a) digitizing each of said plurality of pictures in accordance with a prescribed orientation, irrespective of its actual orientation on said photographic
25 recording medium, and storing, in a digital database, each digitized picture in a respective digital picture data file; and

(b) for each digital picture data file stored in step (a), storing a presentation control file the contents of which are associated with the actual orientation of said picture on said photographic recording medium.

30 12. A method according to claim 11, wherein step (b) comprises storing, within a respective presentation control file, data representative of the aspect ratio of the picture.

13. For use with a digital picture processing system wherein a plurality of photographic pictures that have been captured on a photographic recording medium, and may include horizontally and vertically oriented pictures, are digitized and stored in a digital database, said digital database being capable
5 of being coupled to a picture playback device for display of a picture, a method of controlling the displayed presentation of said picture by said playback device comprising the steps of:

(a) digitizing each of said plurality of pictures captured on said photographic recording medium as though it were captured thereon as a
10 horizontally oriented picture, irrespective of its actual orientation as captured on said photographic recording medium, and storing each digitized picture in said digital database; and

(b) for each digitized picture stored in step (a), storing a first digital code representative of the orientation in which the picture has been captured on said
15 photographic recording medium.

14. A method according to claim 13, wherein step (b) includes storing a second digital code representative of the aspect ratio of the captured picture.

15. For use with a digital picture processing system wherein a plurality of photographic pictures that have been captured on a photographic recording medium are digitized and stored in a digital database, said digital database being capable of being coupled to a picture playback device for display
20 of a picture, a method of controlling the displayed presentation of said picture by said playback device comprising the steps of:

(a) digitizing each of said plurality of pictures on said photographic recording medium and storing each digitized picture in said digital database;

(b) for each digitized picture stored in step (a), storing at least one digital code respectively representative of at least one of the aspect ratio and orientation of the picture; and

(c) reading out a respective digitized picture stored in said digital database
30 in step (a) and coupling the read out digitized picture to a picture playback device in accordance with at least one digital code stored in step (b).

16. A method according to claim 15, wherein step (c) comprises controllably generating border picture signals representative of picture characteristics of at least one border region to be combined with the digitized picture and coupling said border picture signals to said playback device, so that
5 the picture reproduced thereby is bound by said at least one border region.

17. For use with a digitized picture processing system in which pictures that have been captured on a picture recording medium are converted into a digital format and stored as digitized picture data files in a digital database, a method of controlling the reproduction of a stored picture from said
10 digital database comprising the steps of:

(a) accessing a digitized picture data file that has been stored in said digital database and coupling a selected portion of the accessed digitized picture data file to a reproduction device; and

(b) controllably generating border picture signals representative of picture
15 characteristics of at least one border region to be combined with said selected portion of said accessed digitized picture data file and coupling said border picture signals to said reproduction device, so that the picture reproduced thereby is bound by said at least one border region.

18. A method according to claim 17, wherein said digital database
20 contains encoded information representative of the aspect ratio of said picture and wherein step (b) comprises controllably generat picture is to be rotated the address generator 256 is set to a state in which the sequence of addressing the memory locations is adapted in accordance with the desired rotation angle. Figs. 27b, 27c and 27d illustrate how the picture information is stored in the memory
25 for a rotation through an angle of 270, 180 and 90 degrees respectively. For the sake of clarity these Figures only show the positions of the information of the first two picture lines 11 and 12 of the picture.

In the case that a representation of a small picture is to be displayed within the outline of a full-scan representation of another picture or, if
30 desired, the same picture (PIP function), this can be achieved simply by filling the desired location of the picture memory 255 with the low-resolution picture of the subfile TV/4 without magnification. When the picture memory 255 is filled

the address generator 256 is then set to a state in which the information for memory locations is addressed in which the small picture is to be stored. To illustrate this these memory locations are represented as a frame 264 in Fig. 26. During the picture processing described above the presence of the low-resolution picture in the subfile TV/4 again has the advantage that the picture information required to perform this function is directly available in the picture file IP, so that additional processing is not necessary.

When an enlarged representation of a part of the absolutely coded picture is to be displayed the information of a part of the picture, for example the part corresponding to a frame 265, is selected. The information of each pixel of the selected part is loaded into every memory location of a group of 2x2 memory locations, so that a magnified full-scan representation of low resolution is displayed on the display unit. Instead of repeating each pixel 2x2 times in the memory the memory may be filled in accordance with the spatial-interpolation principle mentioned in the foregoing.22, wherein said second means comprises means for storing, within said respective presentation control file, first data representative of the orientation of its associated picture as stored in said digital database.

24. An apparatus according to claim 23, wherein said second means comprises means for storing, within a respective presentation control file, second data representative of the aspect ratio of its associated picture.

25. An apparatus according to claim 22, wherein said second means comprises means for storing, within a respective presentation control file, data representative of the aspect ratio of its associated picture.

26. An apparatus according to claim 22, wherein said system further includes third means for reading out the digitized picture data of a respective data file stored in said digital database in accordance with the contents of its associated presentation control file and coupling the read out picture data to said picture reproduction device such that the picture reproduced thereby is presented in an upright orientation.

27. An apparatus according to claim 26, wherein said picture reproduction device comprises a television display.

28. An apparatus according to claim 27, wherein said television display displays an array of pixels with a resolution different from the resolution of a respective stored picture data file.

5 29. An apparatus according to claim 22, wherein said third means comprises means for controllably generating border picture signals representative of picture characteristics of at least one border region to be combined with read out digitized picture data and coupling said border picture signals to said reproduction device, so that the picture reproduced thereby is bound by said at least one border region.

10 30. An apparatus according to claim 29, wherein said third means comprises means for controllably generating said border picture signals in accordance with the contents of said presentation control file.

15 31. An apparatus according to claim 30, wherein said third means comprises means for controllably generating border picture signals exclusive of the contents of said presentation control file.

32. For use with a digital picture processing system wherein a plurality of pictures that have been captured on a photographic recording medium and may include horizontally and vertically oriented pictures, are digitized into respective digital picture data files, each digital picture data file containing data values associated with an array of M by N pixels corresponding to a prescribed resolution representation of a respective one of said plurality of pictures, an apparatus for controlling the manner in which said digital picture data files are accessed for presentation to a reproduction device, so that a reproduced picture may be viewed in an upright orientation comprising, in combination:

25 first means for digitizing each of said plurality of pictures in accordance with a prescribed orientation, irrespective of its actual orientation on said photographic recording medium, and storing each digitized picture in a respective digital picture data file in a digital database; and

30 second means for storing, in said digital database, in association with each digital picture data file stored by said first means, a presentation control file the contents of which are associated with the actual orientation of its picture as captured on said photographic recording medium.

33. An apparatus according to claim 32, wherein said second means includes means for storing, within a respective presentation control file, data representative of the aspect ratio of the picture.

34. For use with a digital picture processing system wherein a plurality of photographic pictures, that have been captured on a photographic recording medium and may include horizontally and vertically oriented pictures, are digitized and stored in a digital database, said digital database being capable of being coupled to a picture playback device for display of a picture, an apparatus for controlling the displayed presentation of said picture by said playback device comprising, in combination:

first means for digitizing each of the plurality of pictures as captured on said photographic recording medium as though it were captured thereon as a horizontally oriented picture, irrespective of its actual orientation on said photographic recording medium, and storing each digitized picture in said digital database; and

second means for storing, in association with each digitized picture stored in said digital database, a first digital code representative of the orientation of said picture.

35. An apparatus according to claim 34, wherein said second means includes means for storing a second digital code representative of the aspect ratio of the picture.

36. For use with a digital picture processing system wherein a plurality of photographic pictures that have been captured on a photographic recording medium are digitized and stored in a digital database, said digital database being capable of being coupled to a picture playback device for display of a picture, an apparatus for controlling the operation of said playback device comprising, in combination:

a picture digitizer and storage device including first means for digitizing a plurality of pictures that have been captured on said photographic recording medium and storing each digitized picture in said digital database, and second means for storing in said digital database, in association with each stored digitized picture, at least one digital code respectively representative of at least

one of the aspect ratio and orientation of the stored picture; and

a playback device controller including third means for reading out a respective digitized picture stored in said digital database and coupling the read out digitized picture to said picture playback device in accordance with the at least one digital code.

5

37. An apparatus according to claim 36, wherein said playback device controller includes fourth means for controllably generating border picture signals representative of picture characteristics of at least one border region to be combined with the digitized picture read out by said third means and coupling said border picture signals to said playback device, so that the picture reproduced thereby is bound by said at least one border region.

10

38. For use with a digitized picture processing system in which pictures that have been captured on a picture recording medium are converted into digital format and stored as digitized picture data files in a digital database, an apparatus for controlling the reproduction of a picture by a picture reproduction device from a digitized picture data file stored in said digital database comprising, in combination: first means for accessing a digitized picture data file that has been stored in said digital database and coupling a selected portion of the accessed digitized picture data file to said reproduction device; and second means for controllably generating border picture signals representative of picture characteristics of at least one border region to be combined with said selected portion of said accessed digitized picture data file and coupling said border picture signals to said reproduction device, so that the picture reproduced thereby is bound by said at least one border region.

15

20

25

39. An apparatus according to claim 38, wherein said digital database contains encoded information representative of the aspect ratio of said picture and wherein said second means comprises controllably generating border picture signals in dependence upon said encoded information.

30

40. An apparatus according to claim 38, wherein said digital database contains first encoded information representative of the orientation of said picture and wherein said second means comprises means for controllably generating border picture signals in dependence upon said first encoded information.

41. An apparatus according to claim 40, wherein said digital database contains second encoded information representative of the aspect ratio of said picture and wherein said second means comprises means for controllably generating border picture signals in dependence upon said second encoded information.

42. An apparatus according to claim 41, wherein said second means comprises means for controllably generating first border signals in dependence upon said first and second encoded information, and second border signals for defining said least one border region, separate from said first and second encoded information.

43. For use with a digitized picture processing system in which pictures are converted by an opto-electronic device into digital format and stored as digitized picture data files in a digital database, each of said digitized picture data files containing digitized picture data representative of its associated picture as converted by said optoelectronic device into digital format, and a respective presentation control file for each of said respective data files, the contents of a respective presentation control file being representative of the manner in which its associated digitized picture data has been converted by said opto-electronic device into digital format and stored as a digitized picture in said digital database, a playback apparatus for controlling the manner in which digitized pictures are accessed from said digital database for presentation on a picture reproduction device comprising, in combination:

a digital data memory;
first means for reading from said digital database the digitized picture data of a respective data file and writing the read out digitized picture data into said digital data memory; and

second means for controllably reading out digitized picture data that has been written into said digital data memory in a manner that depends upon the contents of its associated presentation control file and coupling the read out data to a picture reproduction device such that the reproduced picture is reproduced by said picture reproduction device in an upright orientation.

44. An apparatus according to claim 43, wherein a respective

presentation control file contains data representative of the orientation of its associated picture as stored in said digital database.

45. An apparatus according to claim 43, wherein a respective presentation control file contains data representative of the aspect ratio of its associated picture as stored in said digital database.

46. An apparatus according to claim 43, wherein said second means includes means for controllably generating border picture signals representative of picture characteristics of at least one border region to be combined with read out digitized picture data and coupling said border picture signals to said reproduction device, so that the picture reproduced thereby is bound by said at least one border region.

47. For use with a digitized picture processing system in which pictures captured by an electronic still camera are converted into digital format and stored as digitized picture data files in a digital database, each of said digitized picture data files containing digitized picture data representative of its associated picture as captured by said still camera and converted into digital format, and a respective presentation control file for each of said respective data files, the contents of a respective presentation control file being representative of the manner in which its associated digitized picture data has been captured and converted into digital format and stored as a digitized picture in said digital database, a playback apparatus for controlling the manner in which digitized pictures are accessed from said digital database for presentation on a picture reproduction device comprising, in combination:

a digital data memory;

25 first means for reading from said digital database the digitized picture data of a respective data file and writing the read out digitized picture data into said digital data memory; and

second means for controllably reading out digitized picture data that has been written into said digital data memory in a manner that depends upon the contents of its associated presentation control file and coupling the read out data to a picture reproduction device such that the reproduced picture is reproduced by said picture reproduction device in an upright orientation.

48. An apparatus according to claim 47, wherein a respective presentation control file contains data representative of the orientation of its associated picture as stored in said digital database.

49. An apparatus according to claim 47, wherein a respective presentation control file contains data representative of the aspect ratio of its associated picture as stored in said digital database.

50. A digital data base medium on which a plurality of data files has been stored each representing a digitized picture, characterized in that control data has been stored, which represent the manner in which its associated digitized picture has been digitized.

51. A digital data base medium as claimed in claim 50, characterized in that said control data is representative of the orientation of the picture when it was digitized.

52. A digital data base medium as claimed in claim 50 or 52, wherein the data files represent pictures that have been captured on a photographic recording medium and may include horizontally and vertically oriented pictures, each digital picture data file containing data values associated with an array of M by N pixels corresponding to a prescribed resolution representation of a respective one of said plurality of pictures.

53. A data base medium as claimed in any one of the claims 50, 51 or 52, wherein the data base medium comprises an optical record carrier on which the files have been recorded in conformity with a CD-format.

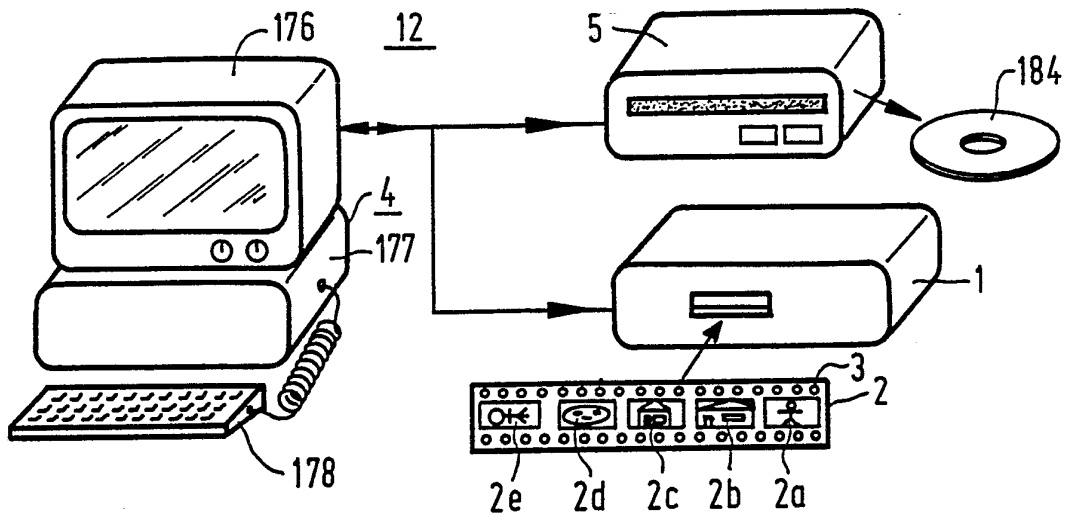

FIG. 1a

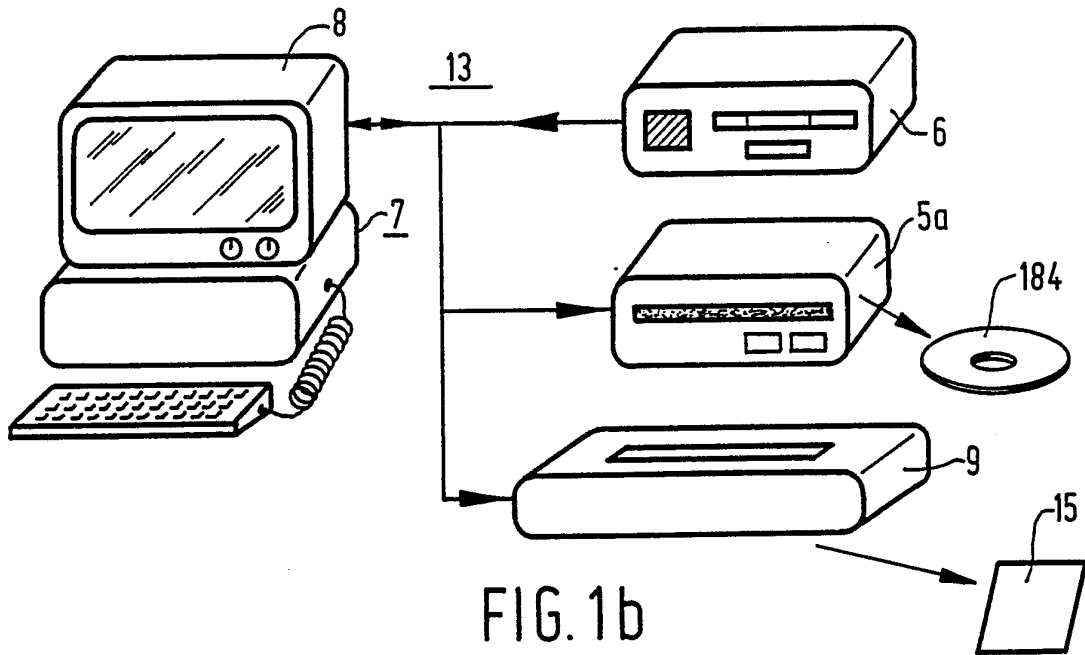

FIG. 1b

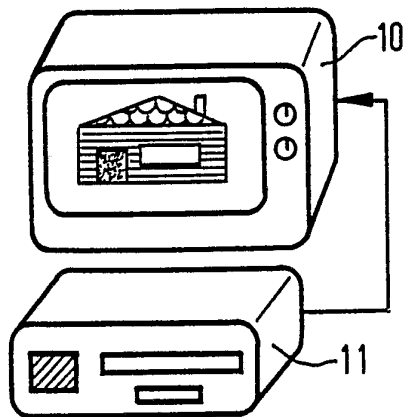

FIG. 1c

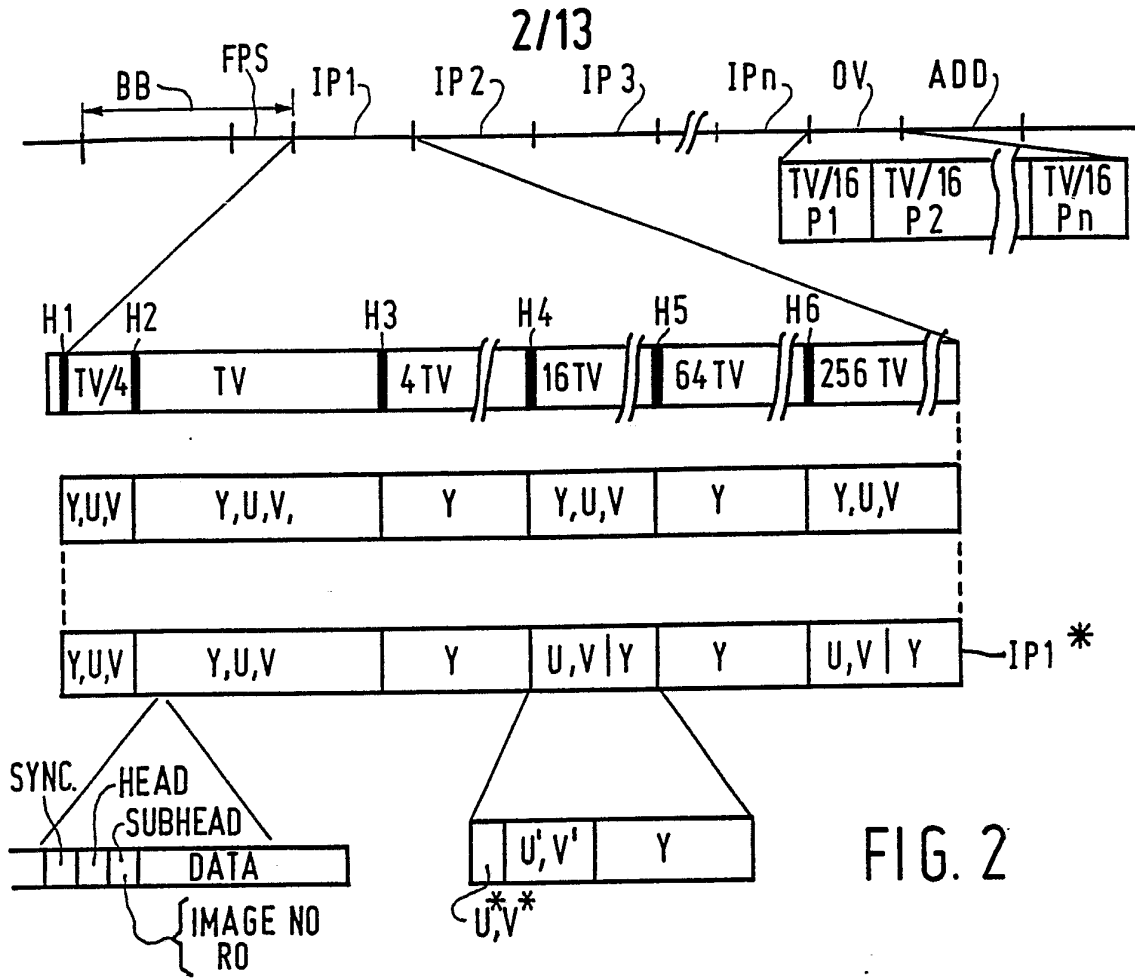

FIG. 2

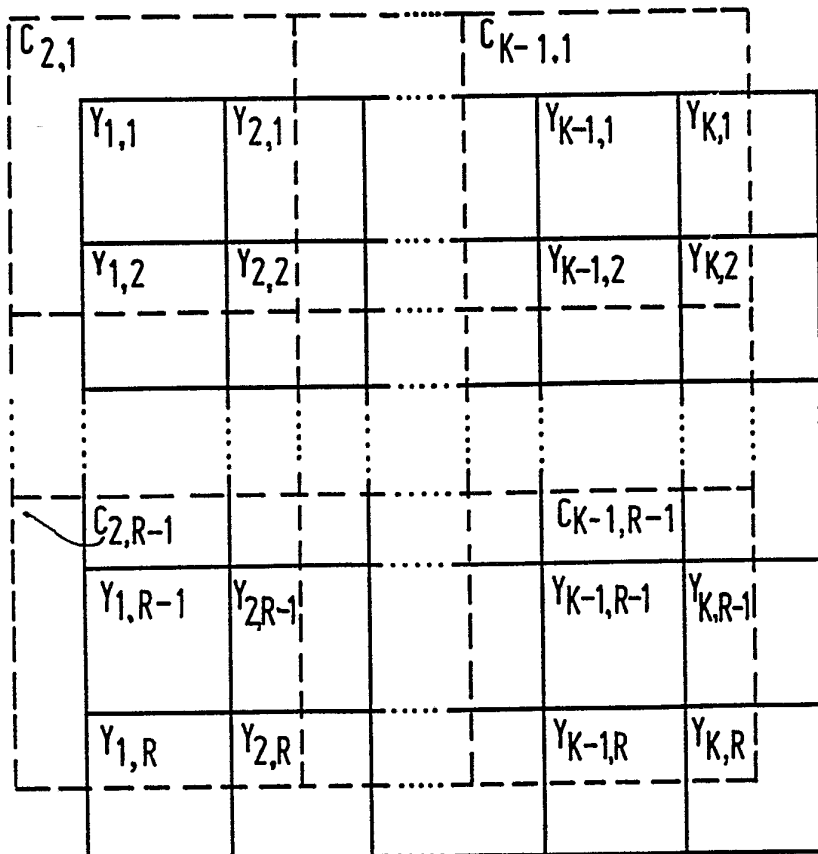

FIG. 3

3/13

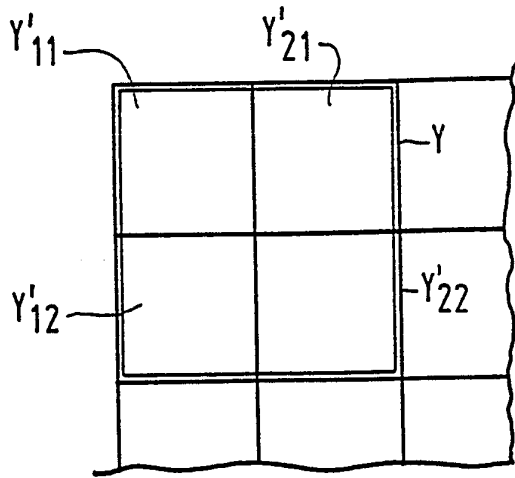

FIG. 4

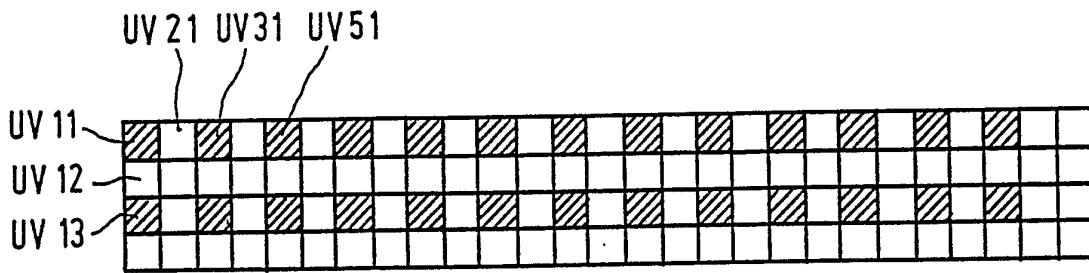

FIG. 5

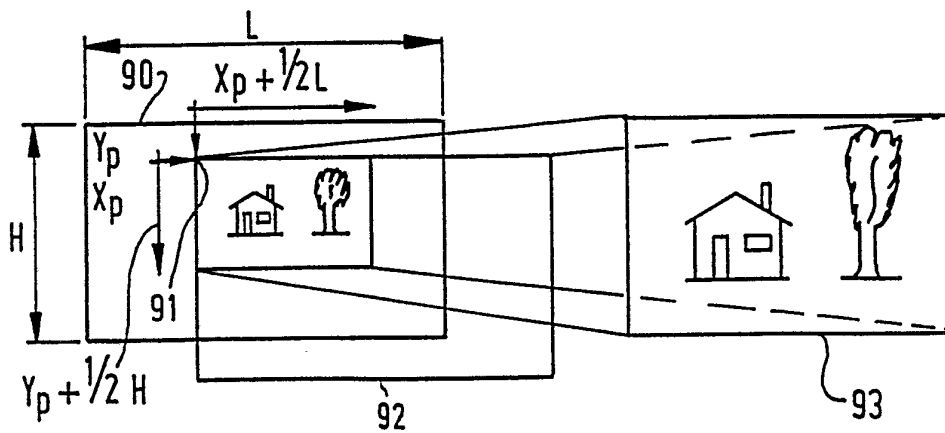
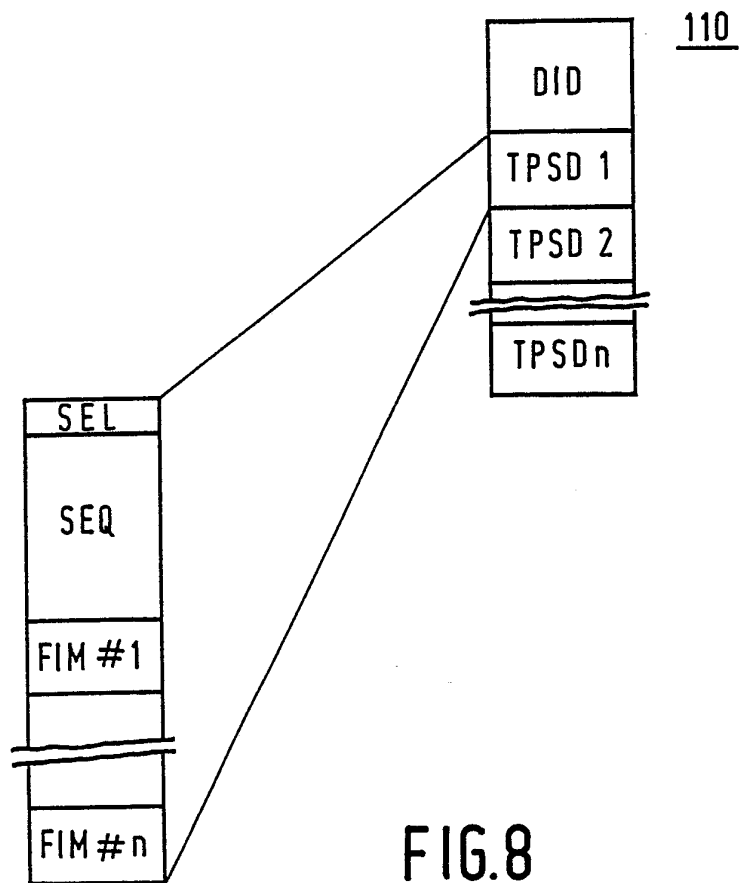
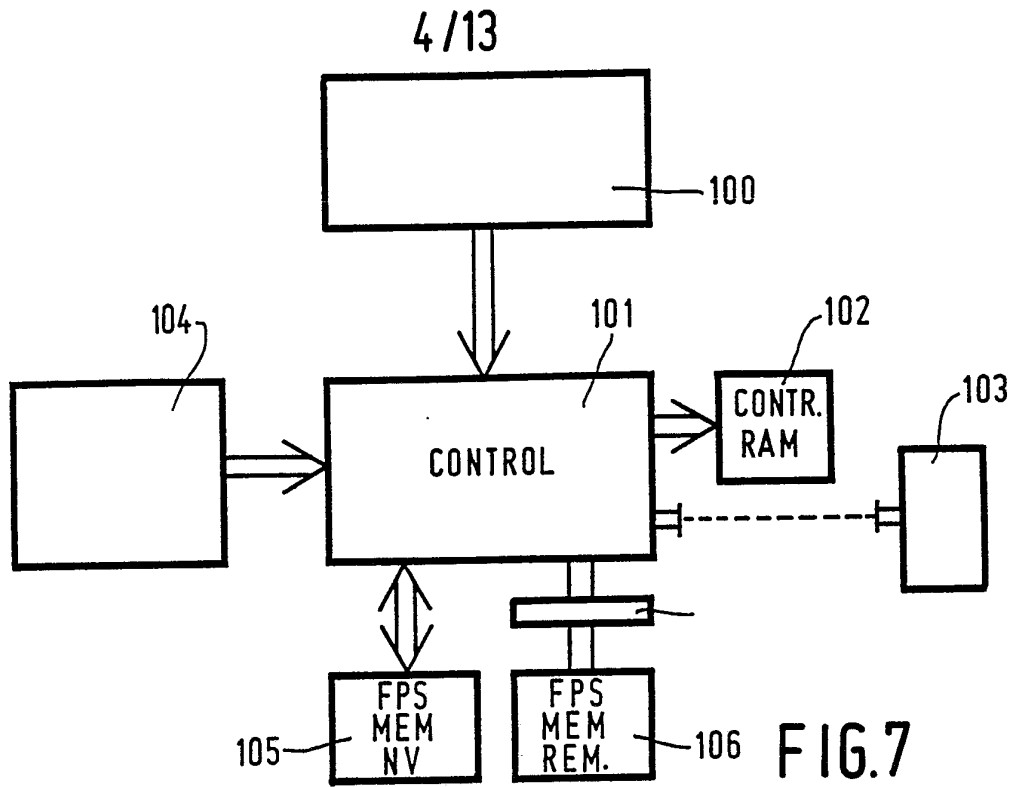

FIG. 6



5/13

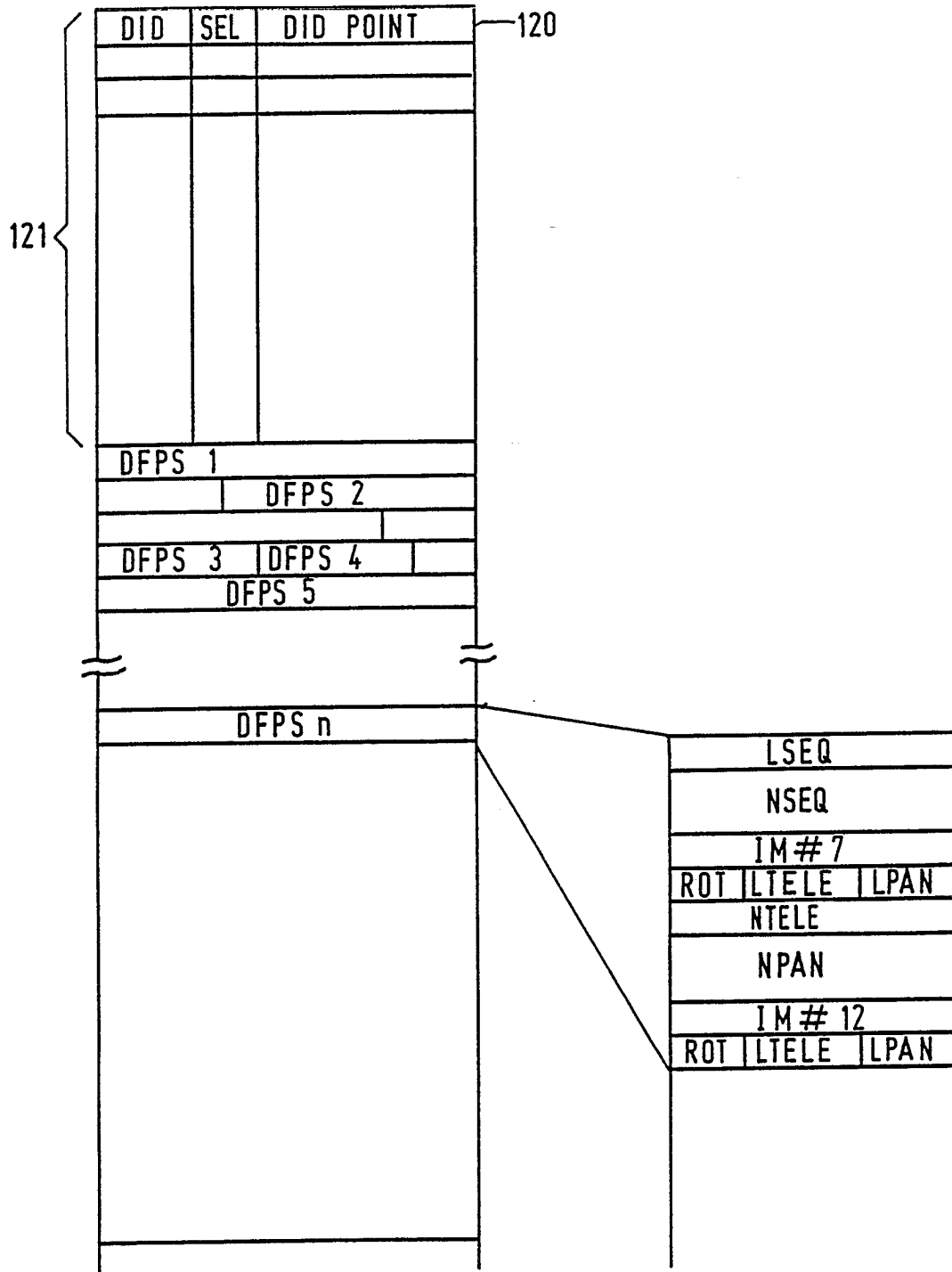

FIG.9

6/13

IM# 1	IM# 3	IM# 5	IM# 30
IM# 27	IM# 12	IM# 13	IM# 15
IM# 16	IM# 18	IM# 20	IM# 21
IM# 22	IM# 23	IM# 24	IM# 26

FIG. 10

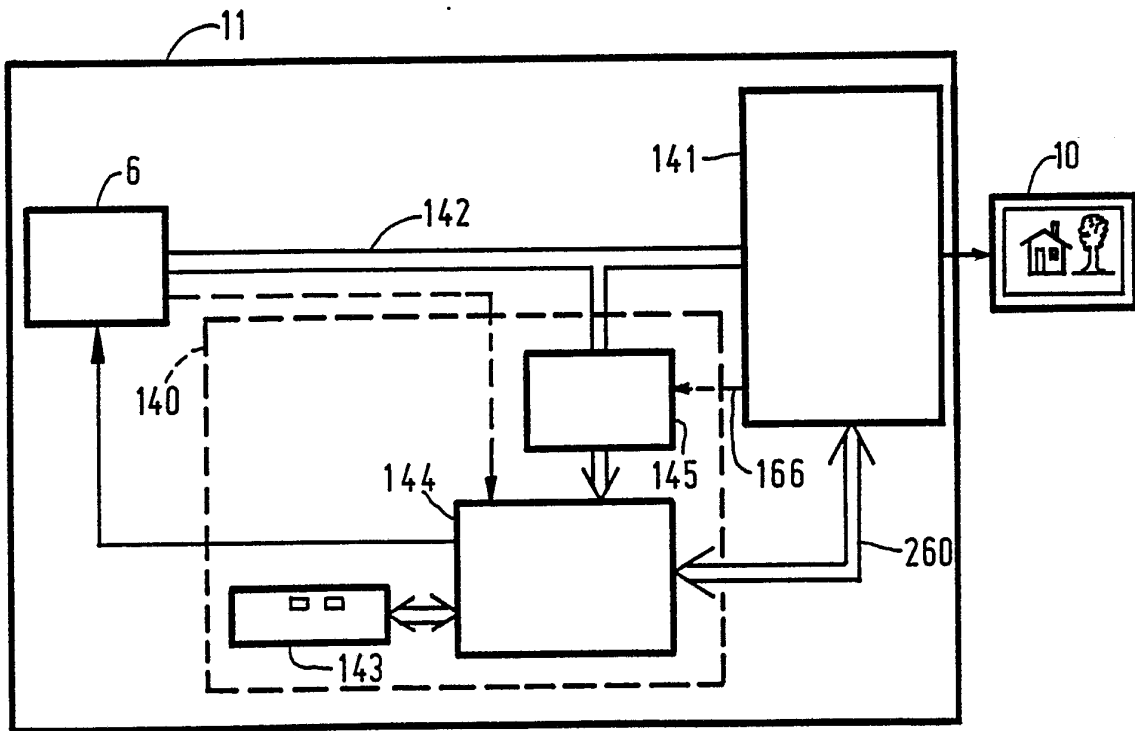

FIG. 11

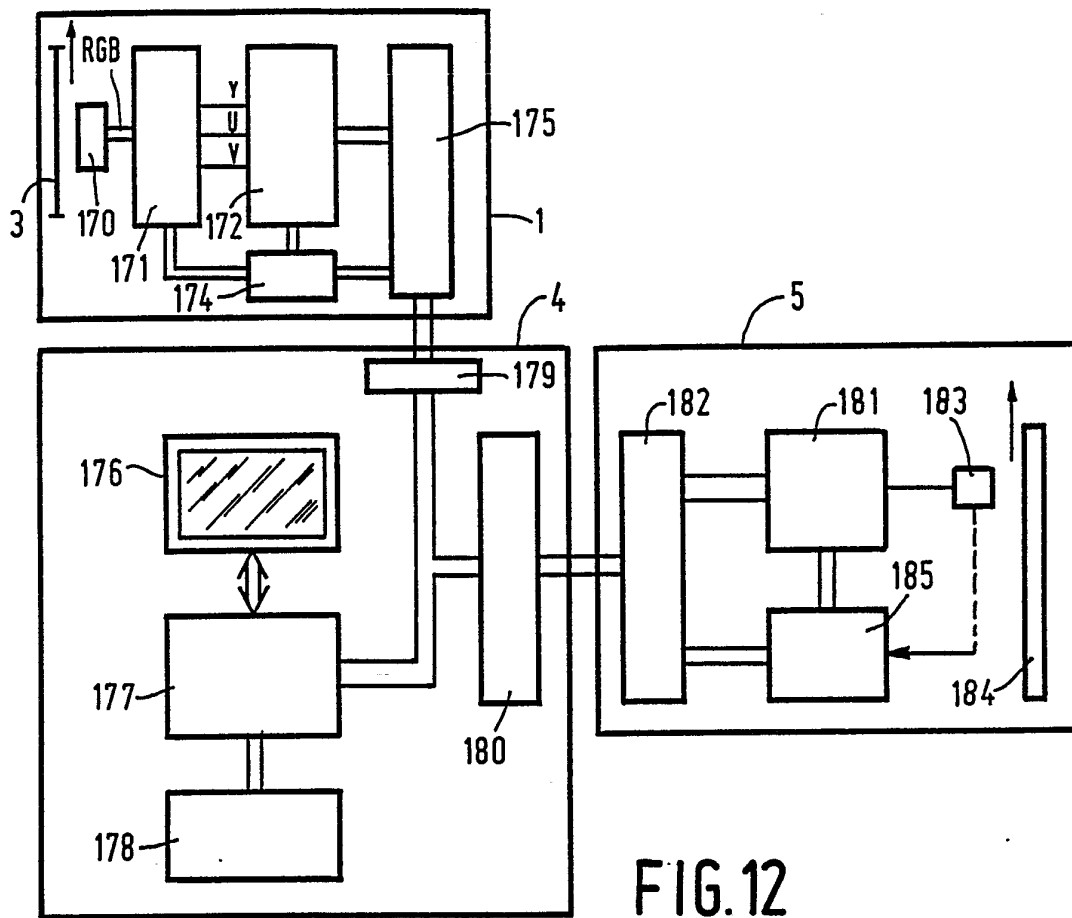

FIG. 12

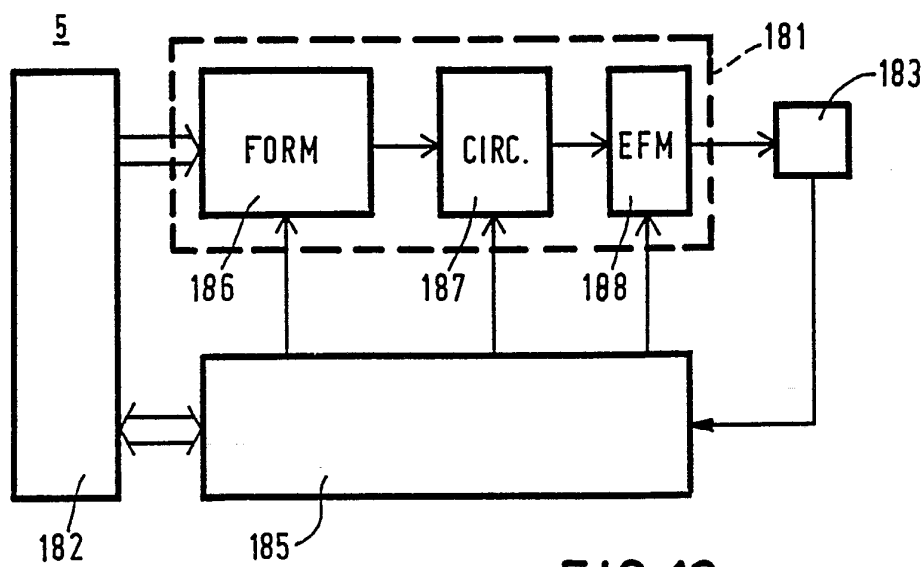

FIG. 13

8/13

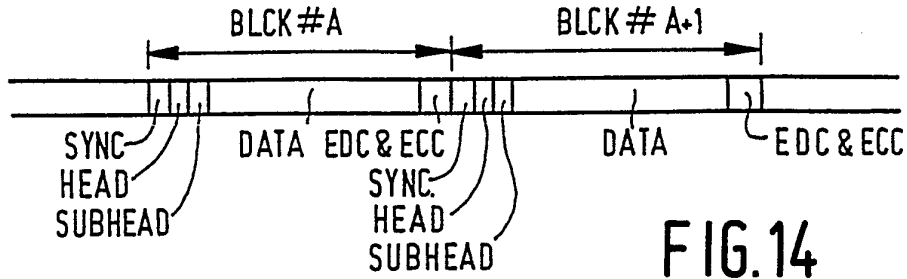

FIG.14

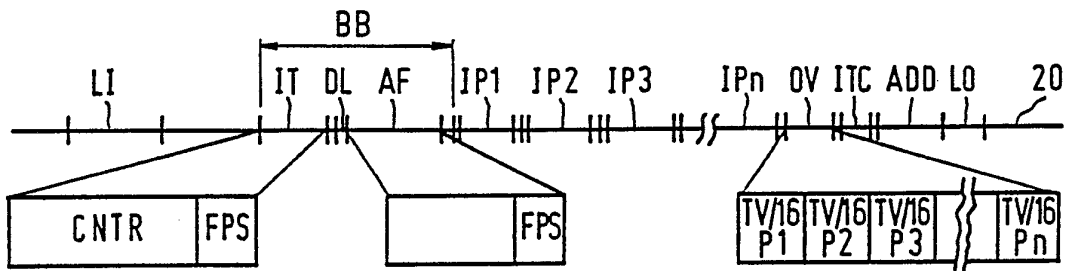

FIG.15

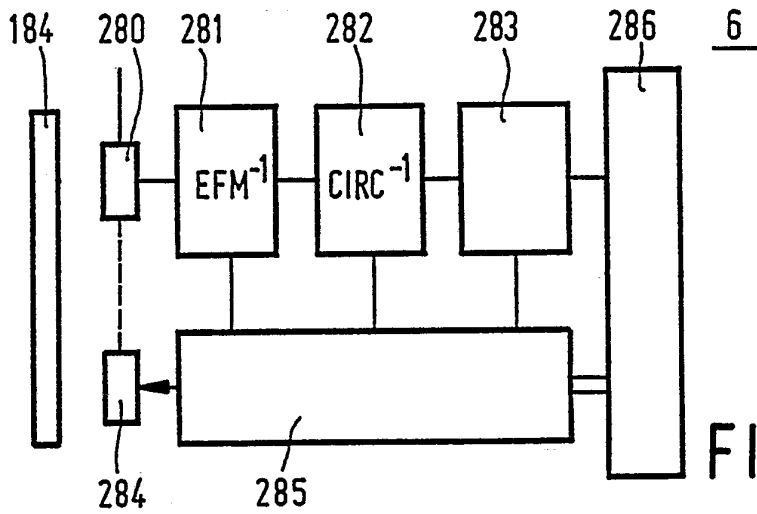

FIG.19

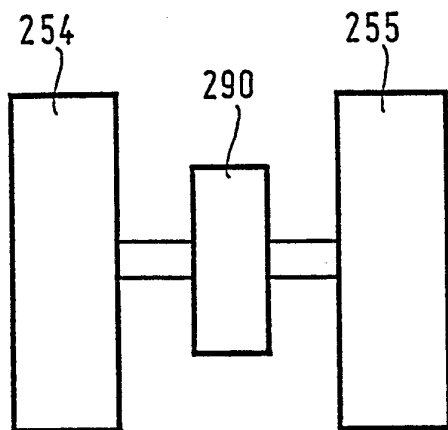

FIG.20

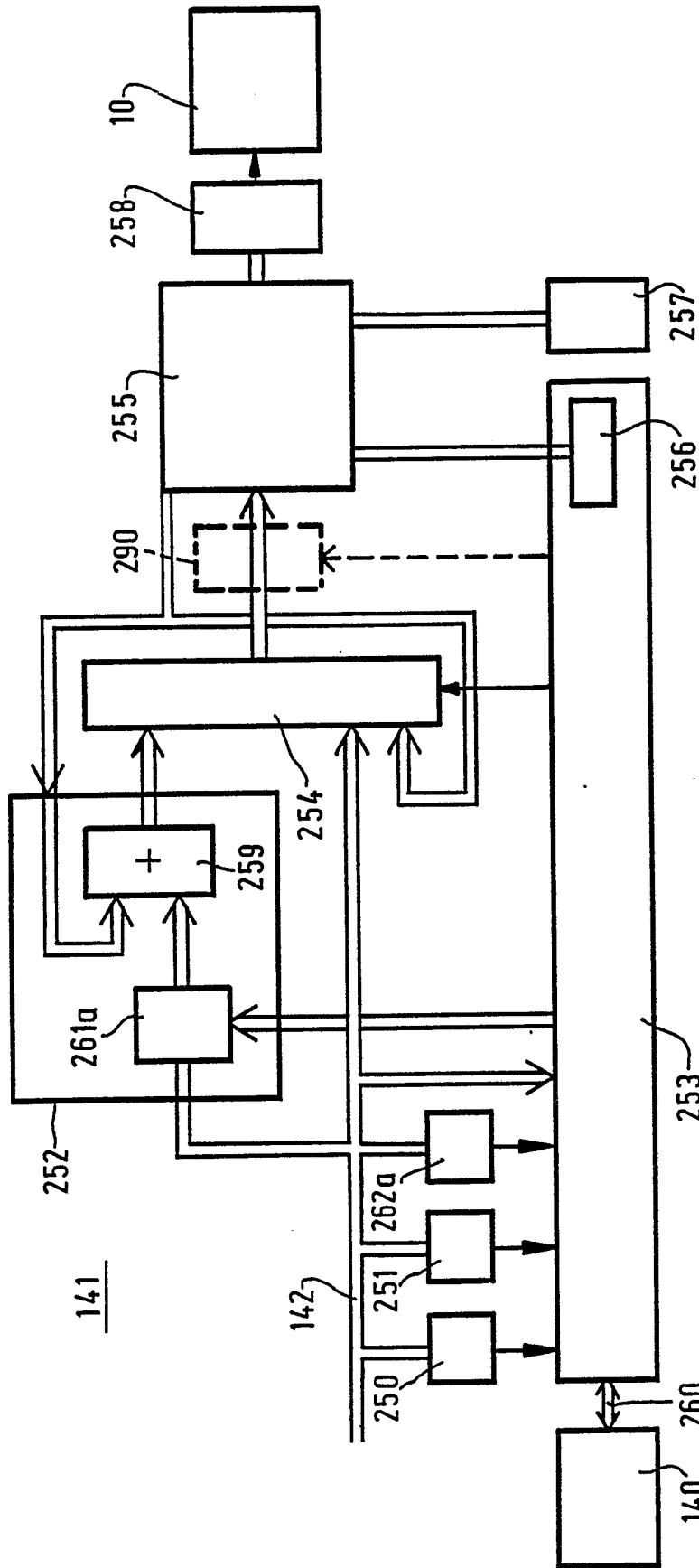

FIG. 16

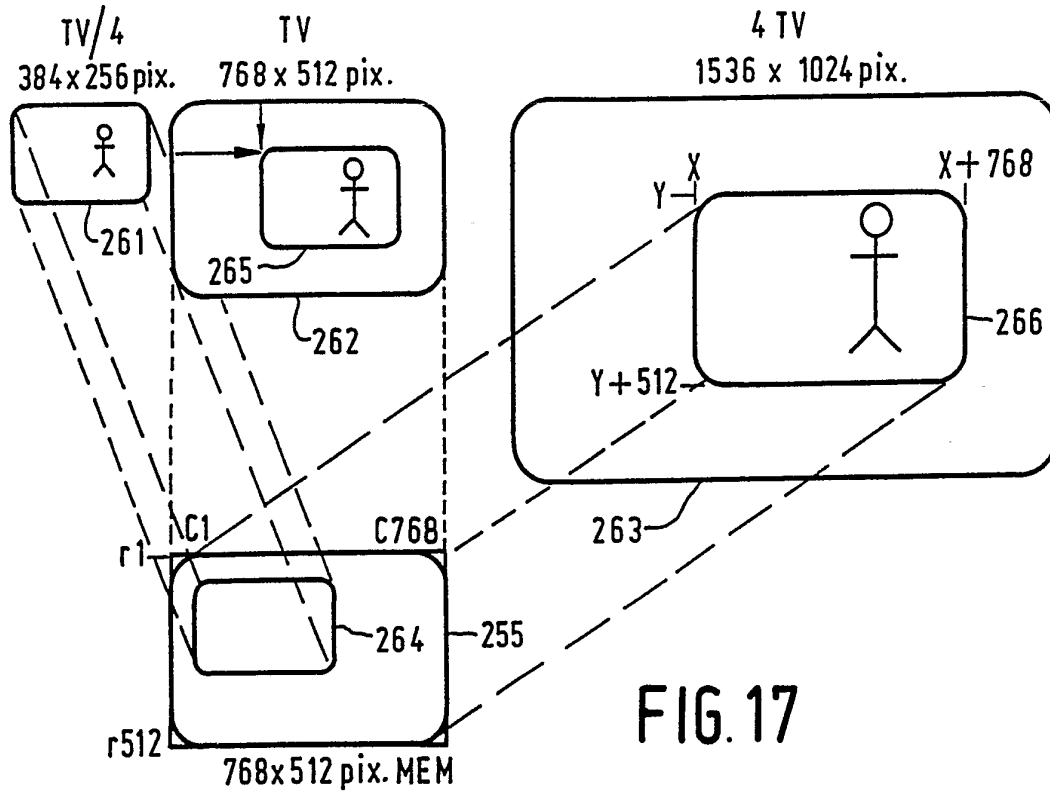

FIG. 17

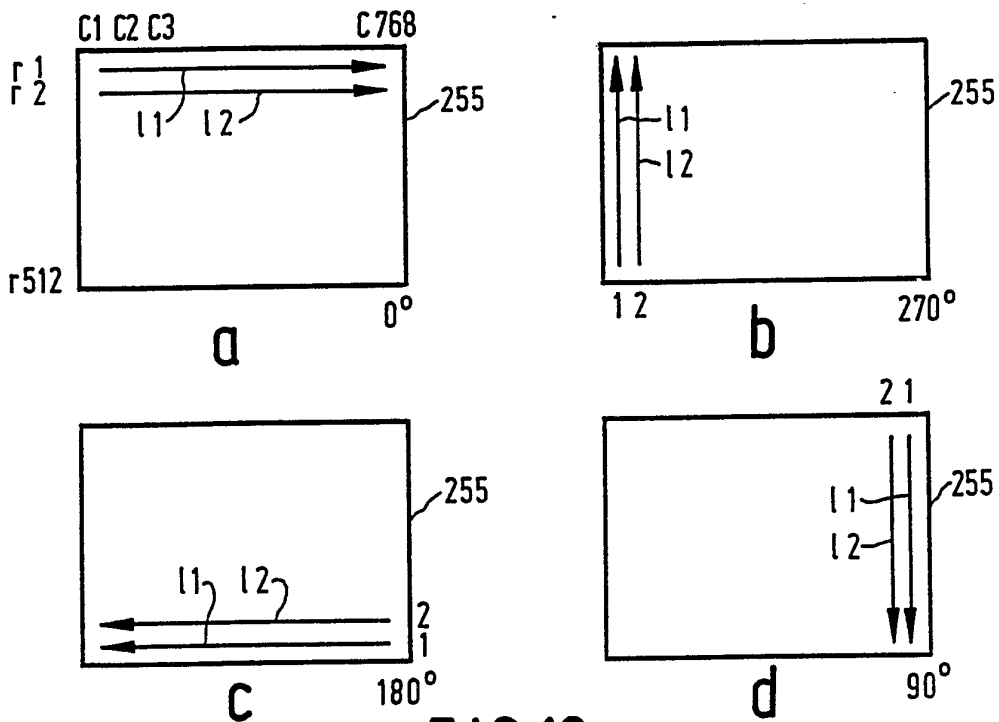
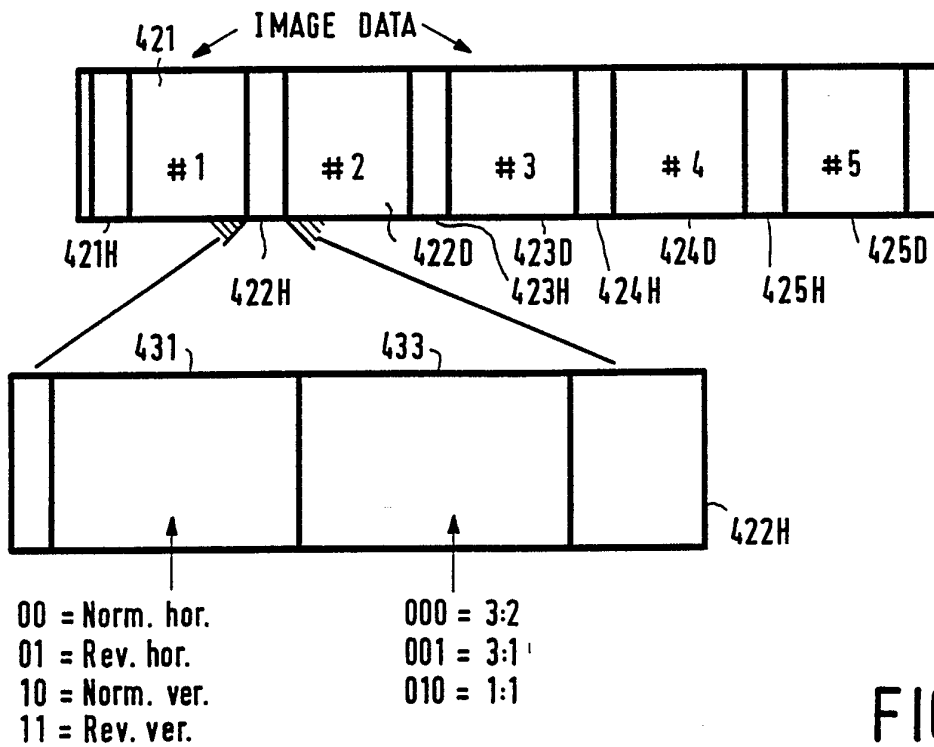
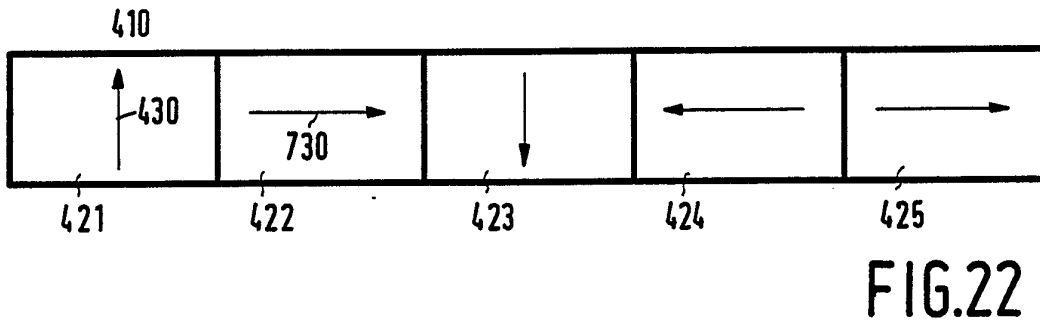
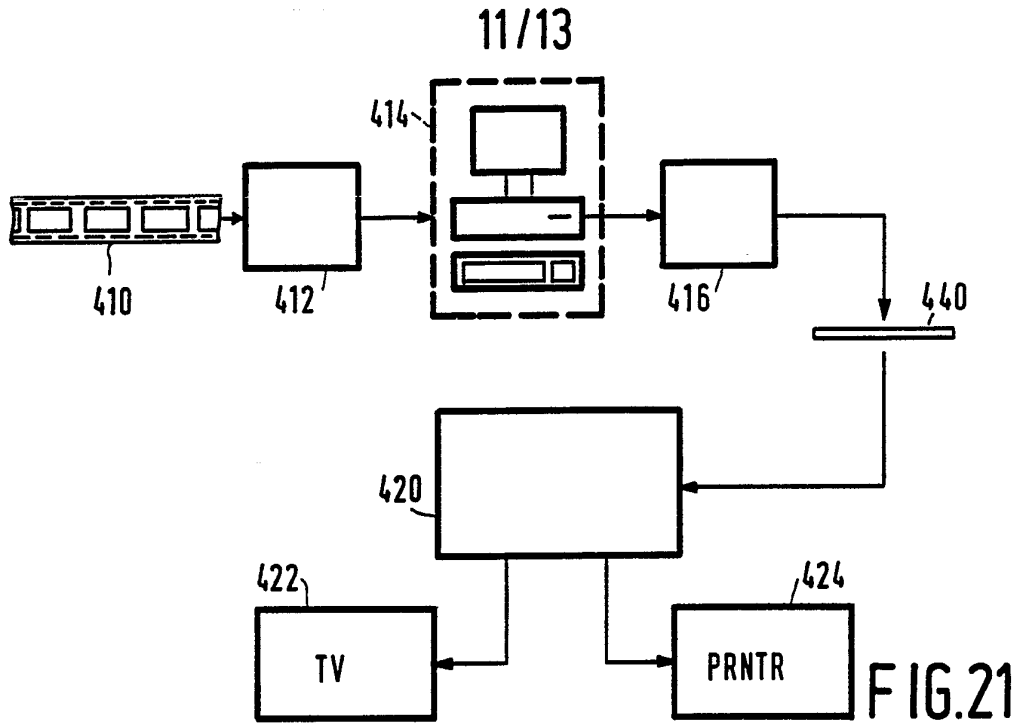

FIG. 18



12/13

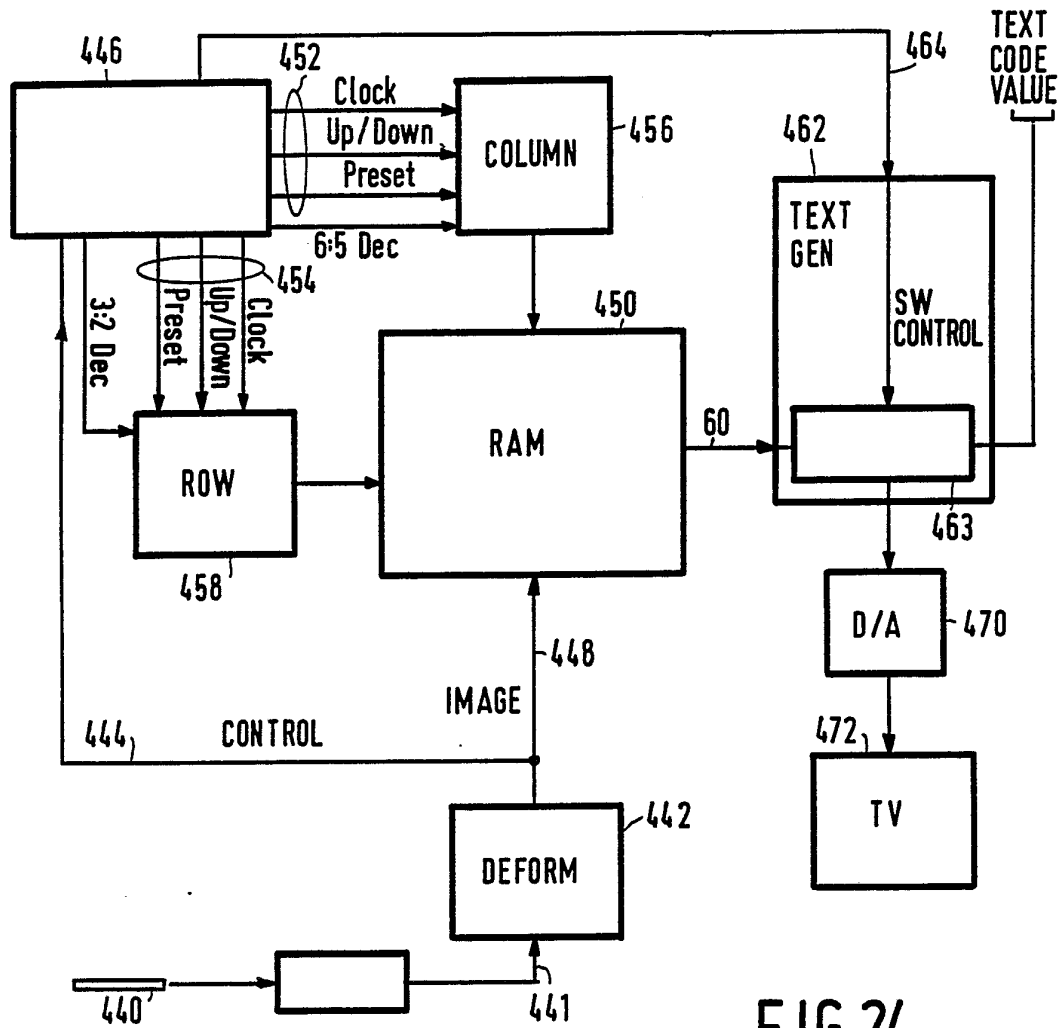

FIG. 24

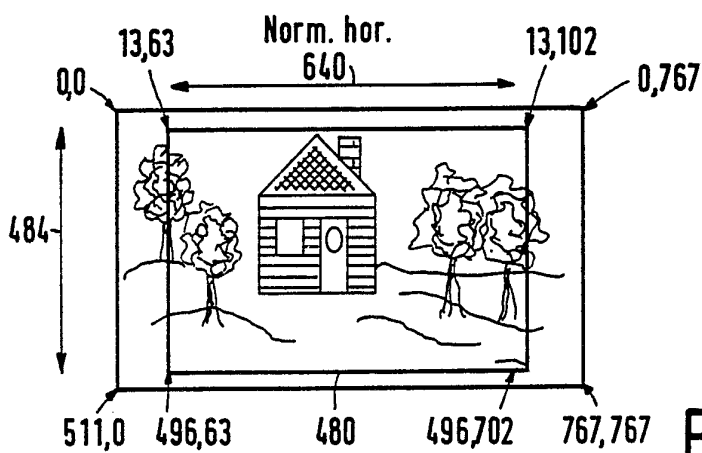

FIG. 25

13/13

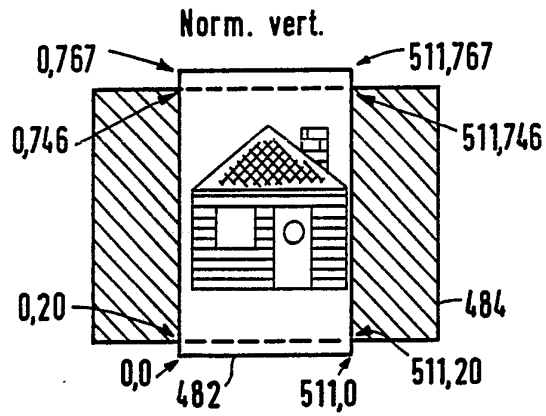

FIG.26

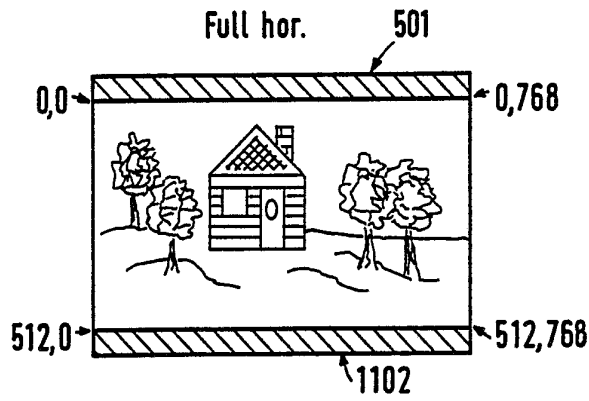

FIG.27

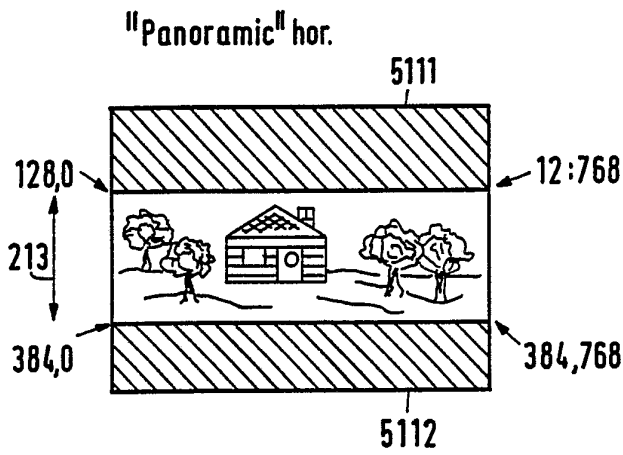

FIG.28

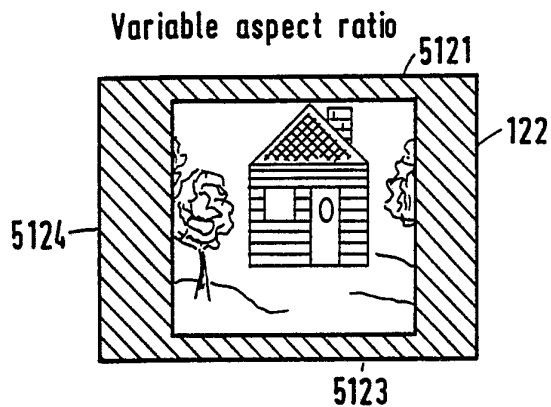

FIG.29