

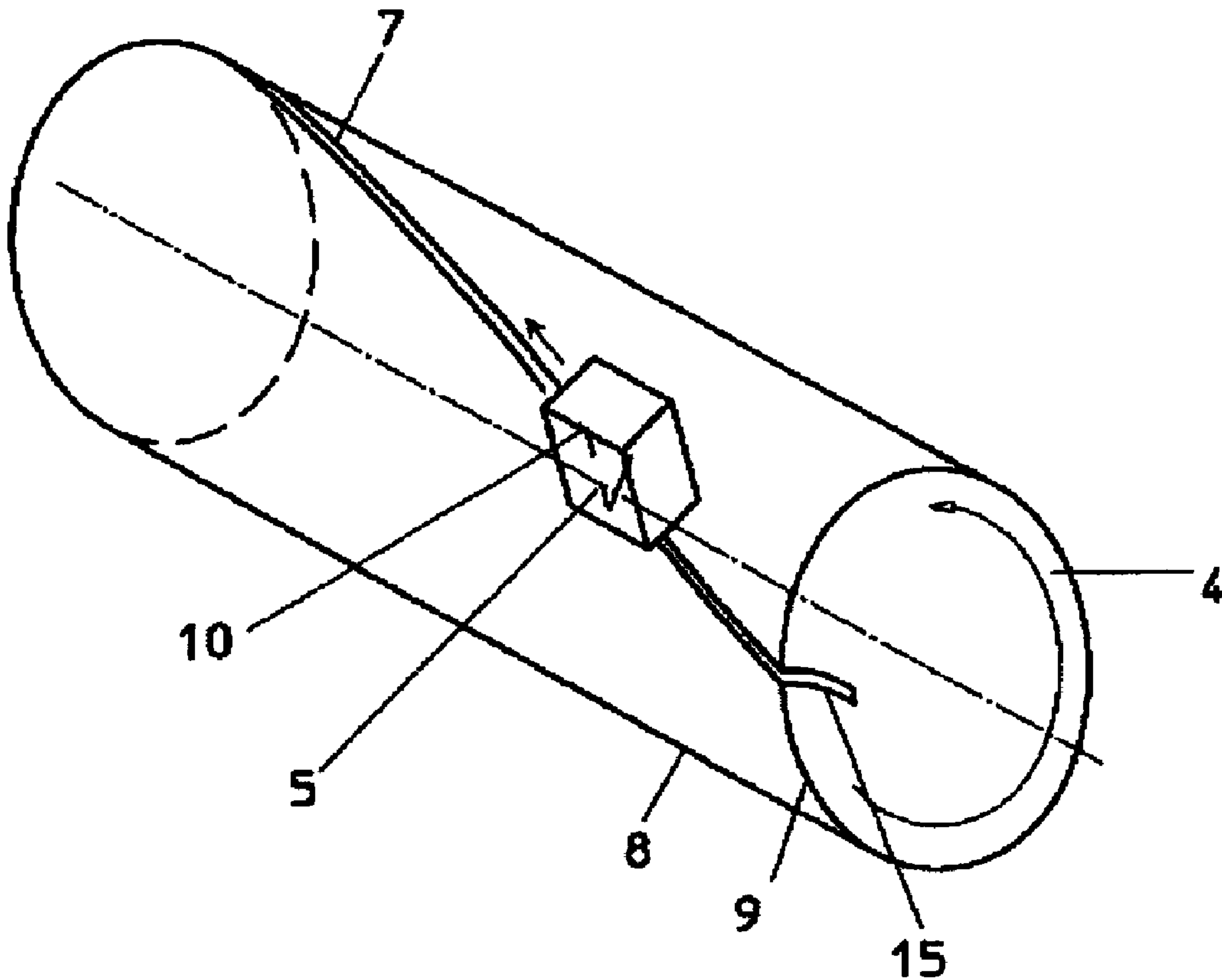

(22) Date de dépôt/Filing Date: 2005/04/04  
 (41) Mise à la disp. pub./Open to Public Insp.: 2005/10/08  
 (45) Date de délivrance/Issue Date: 2010/02/02  
 (30) Priorité/Priority: 2004/04/08 (DE10 2004 017 471.7)

(51) Cl.Int./Int.Cl. *B65H 35/04* (2006.01),  
*B26D 1/04* (2006.01), *B26D 1/10* (2006.01),  
*B26D 1/36* (2006.01), *B65H 75/32* (2006.01)  
 (72) Inventeur/Inventor:  
 HENNES, JOCHEN, DE  
 (73) Propriétaire/Owner:  
 KIEFEL EXTRUSION GMBH, DE  
 (74) Agent: FETHERSTONHAUGH & CO.

(54) Titre : ROULEAU DE TRANSPORT D'AMES DE MATERIAU  
 (54) Title: TRANSPORTING ROLLER FOR WEBS OF MATERIAL



(57) Abrégé/Abstract:

The transporting roller (4), which serves for transporting a web of material which is wound up onto a winding shaft, is provided with a cutting device, which comprises a cutter (5) and a cutter holder (10). The transporting roller (4) has a groove (7), in which the

(57) **Abrégé(suite)/Abstract(continued):**

cutter (5) is guided. A catching device (15) permits the introduction of the cutter (5) into the groove (7). The groove (7) is inclined with respect to an axially parallel generatrix, so that the web of material is cut off at an oblique angle.

**ABSTRACT**

The transporting roller (4), which serves for transporting a web of material which is wound up onto a winding shaft, is provided with a cutting device, which comprises a cutter (5) and a cutter holder (10). The transporting roller (4) has a groove (7), in which the cutter (5) is guided. A catching device (15) permits the introduction of the cutter (5) into the groove (7). The groove (7) is inclined with respect to an axially parallel generatrix, so that the web of material is cut off at an oblique angle.

(Figure 6)

30698-18

- 1 -

**TRANSPORTING ROLLER FOR WEBS OF MATERIAL**

The invention relates to a transporting roller for webs of material with a cutting device for the web of material provided outside the transporting roller.

For carrying out a cutting operation which takes place outside the transporting roller, a known transporting roller of this type is provided with a deflecting roller, which lifts the web of material off the transporting roller in order that the cutter, which can be moved from one edge of the roller to the opposite edge of the roller, does not damage the transporting roller. Lifting the web of material off the transporting roller by means of a deflecting roller can cause variations in tension in the web of material, with an adverse influence on the winding result. Furthermore, the lifting-off can in this case cause the web of material to run out laterally, which likewise has a considerable adverse influence on the quality of the wound roll. Turning over of the web of material after cutting likewise cannot always be ensured.

An aspect of the invention is to avoid lifting the web of material off the transporting roller during the cutting operation and in this way improve the quality of the wound roll considerably.

The invention relates to, in the case of a transporting roller of the type explained at the beginning according to the invention by the cutting device having at least one cutter which, during the cutting operation, is guided in a groove of the transporting roller in such a way that it can move in the longitudinal direction of said roller, which groove runs at an angle in relation to an axially parallel generatrix of the transporting roller, and by the cutter movement being controllable

- 2 -

in dependence on the circumferential speed of the transporting roller.

On the basis of this configuration, it is no longer  
5 necessary for the web of material to be lifted off the transporting roller for cutting it, whereby the disadvantages explained at the beginning are avoided and the quality of the wound roll is improved considerably. It was previously only possible to avoid  
10 lifting-off from the transporting roller with cutting devices arranged in the interior of the transporting roller, the arrangement of which however requires significantly greater technical expenditure than is the case with a cutting device outside the transporting  
15 roller.

In an advantageous configuration of the invention it is provided that, if a single cutter is used, the groove runs from one side edge of the transporting roller to  
20 the opposite edge. This produces a particularly simple configuration, which also permits simple control of the cutter movement.

In this case, the included angle which the groove forms  
25 with the axially parallel generatrix can be constant or variable over the length of the groove.

According to a further advantageous configuration of the invention, for the driving of the cutter, it may be  
30 coupled to the transporting roller drive by means of a gear mechanism.

Instead of this mechanical coupling, it may also be provided that the drive of the cutter comprises an  
35 electric actuator, which is coupled to an actuator of the transporting roller drive by means of a control device.

- 3 -

A particularly simple configuration consists in that the drive of the cutter takes place by the edge of the groove in the manner of a motion-transmitting screw thread, and that a catching device for the cutter is  
5 provided at the beginning of the groove.

As from a certain angle of pitch of the groove with respect to the axially parallel generatrix, the cutter is displaced in the groove by the rotational movement  
10 of the roller without requiring a separate drive. It is merely necessary for the intended cutting operation to bring the cutter into the region of the device, in order to be able to introduce the cutter into the groove.

15 If, instead of an obliquely angled cut edge of the web of material, a pointed cut edge is desired, in order to obtain a more uniform beginning of the roll and thereby at the same time also increase the cutting speed, it is  
20 provided in a further configuration that the transporting roller has two crossing grooves and that two cutters that are movable in opposite directions are arranged.

25 This essentially produces a V-shaped arrangement of the grooves, which results in a pointed end of the cut web of material, and consequently easy winding up, whereby a roll without an oblique linear edge, and consequently a roll which is largely free from imbalance, is  
30 created. The essentially V-shaped form of the end of the web of material thereby created has an exactly cut point, since, with two cutters which cross each other, they pass through the crossing point at different times, which results in an exactly guided cut, even at  
35 the point of the cut-off web of material.

Depending on the desired form of the cut end of the web of material, the crossing point of the two grooves may be at the same distance from the edges of the

30698-18

- 4 -

transporting roller or at different distances.

According to a further configuration of the invention,  
at least two portions of the crossing grooves can run  
5 in each case to a side edge of the transporting roller.  
This means that, after passing through the crossing  
point, the cutters are removed from the grooves. It is  
also possible, however, that all the portions of the  
crossing grooves run to the side edges, whereby a  
10 continuous cutting movement of the respective cutters  
from one side edge to the opposite side edge is  
obtained.

The grooves may run at the same angle in relation to  
15 the axially parallel generatrix or else at different  
angles in relation to this generatrix, depending on  
which cutting shape is desired.

If, in a further configuration of the invention, the  
20 cutters are guided independently of each other, it is  
possible that they can be driven in an advantageous way  
at the same speed or at different speeds. Different  
speeds will be chosen if the cut of the two cutters is  
to end at the same time, so that the cutter starting  
25 later is driven more quickly. The control must always  
ensure, however, that the cutters pass through the  
crossing point at different times.

30698-18

- 4a -

The invention also relates to a transporting roller of the type specified at the beginning by the cutting device having a cutter which is movable essentially perpendicularly in relation to the web of material, toward it and away from it again, in the manner of a hacking device, which enters a groove provided in the transporting roller while simultaneously cutting through the entire width of the web of material.

The invention further relates to a cutting apparatus for cutting a moving web, the apparatus comprising: a moving web transporting roller disposed in a web transporting path for cooperation with a moving web and supported for rotation about a longitudinal axis, the moving web transporting roller having a surface for supporting a web thereon, the surface defined by an axially parallel generatrix, the transporting roller further having a groove which intersects the surface and runs in a longitudinal direction at an angle to the axially parallel generatrix of the moving web transporting roller; a cutting device having at least one cutter which is guided in the groove in the longitudinal direction of the groove, wherein a substantial portion of the cutting device is disposed outside of the transporting roller, and the cutter has a cutting portion that is aligned with and cooperates with the groove for cutting the web in a substantially axial direction; and means for controlling the movement of the cutter in dependence on a circumferential speed of the moving web transporting roller, wherein the groove extends from one axial end of the moving web transporting roller to the other axial end of the moving web transporting roller, and wherein the cutting device is supported such that it is movable parallel to the longitudinal axis of the transporting roller; and wherein the cutting device has only one cutter.

- 5 -

The invention is explained in more detail below on the basis of several exemplary embodiments that are represented in the drawing, in which:

- 5 **Figure 1** shows a side view of a transporting roller in connection with a roll of a web of material;
- Figure 2** shows a diagrammatic representation of the transporting roller on an enlarged scale;
- 10 **Figure 3** shows a side view, corresponding to Figure 1, of a further embodiment of a transporting roller;
- 15 **Figure 4** shows the transporting roller from Figure 3 in a diagrammatic representation on an enlarged scale;
- Figure 5** shows a representation corresponding to  
20 Figures 1 and 3 of a third embodiment of a transporting roller; and
- Figure 6** shows the transporting roller from Figure 5  
25 in a diagrammatic representation and on an enlarged scale.

As can be seen from Figures 1, 3 and 5, a winding shaft 2, on which a roll 6 of a web of material 3 is wound up, is rotatably mounted on a carrying arm 1. The web  
30 of material 3 runs over a transporting roller 4, which is in constant contact with the roll 6.

For cutting through the web of material 3 when the roll 6 has reached its intended size, a cutter holder 10 is  
35 provided with a cutter 5, which is guided in a groove 7, as can be seen from Figures 2, 4 and 6. The groove 7 runs from one edge 9 to the opposite edge at an angle in relation to an axially parallel generatrix 8.

- 6 -

In its displacing movement from the edge 9 to the opposite edge of the transporting roller 4, the cutter 5 with its cutter holder 10 must be synchronized with the circumferential speed of the transporting roller 4, that is to say the movement of the cutter is controlled in dependence on the circumferential speed of the transporting roller 4.

Represented in Figure 2 is an embodiment of a transporting roller above which the cutter holder 10 is guided on a spindle 11, which is set in rotation by an electric spindle drive 12. The cutter holder 10 is, as it were, a movable nut on the spindle 11. An electric drive for the transporting roller 4 is denoted by 16 and the two drives 12 and 16 are synchronized by means of a control 13 in such a way that the cutter holder 10, and consequently the cutter 5, is controlled in its sequence of movements in the groove 7 in dependence on the circumferential speed of the transporting roller 4.

20

In the case of the embodiment that is shown in Figure 4, the coupling between the cutter drive and the transporting roller drive is a gear mechanism in the form of a belt drive 14, which transmits the rotating movement of the transporting roller 4 to the spindle 11, the diameter ratio of the two belt pulleys 17 and 18 being chosen such that the cutter 5 is moved in the groove 7 from the edge 9 to the opposite edge of the transporting roller 4 when the transporting roller 4 has turned through the angular region enclosed by the two ends of the groove 7.

30

In the case of the exemplary embodiment that is shown in Figure 6, the cutter 5 is guided by an edge of the groove 7, a catching device 15 being provided, permitting introduction of the cutter 5 into the groove 7.

35

- 7 -

All three embodiments permit the cutting of a web of material when the corresponding wound roll has been completed.

30698-18

- 8 -

CLAIMS:

1. A cutting apparatus for cutting a moving web, the apparatus comprising:

a moving web transporting roller disposed in a web  
5 transporting path for cooperation with a moving web and supported for rotation about a longitudinal axis, the moving web transporting roller having a surface for supporting a web thereon, the surface defined by an axially parallel generatrix, the transporting roller further having a groove  
10 which intersects the surface and runs in a longitudinal direction at an angle to the axially parallel generatrix of the moving web transporting roller;

a cutting device having at least one cutter which is guided in the groove in the longitudinal direction of the groove,  
15 wherein a substantial portion of the cutting device is disposed outside of the transporting roller, and the cutter has a cutting portion that is aligned with and cooperates with the groove for cutting the web in a substantially axial direction; and

20 means for controlling the movement of the cutter in dependence on a circumferential speed of the moving web transporting roller,

wherein the groove extends from one axial end of the moving web transporting roller to the other axial end of the moving  
25 web transporting roller, and wherein the cutting device is supported such that it is movable parallel to the longitudinal axis of the transporting roller; and

wherein the cutting device has only one cutter.

2. The cutting apparatus of claim 1, wherein the  
30 angle at which the groove runs is a constant angle to the

30698-18

- 9 -

axially parallel generatrix of the moving web transporting roller.

3. The cutting apparatus of claim 1, wherein the means for controlling the movement of the cutter comprises a  
5 belt drive device.

4. The cutting apparatus of claim 1, wherein the means for controlling the movement of the cutter comprises:

a drive for the moving web transporting roller;

a drive for the cutter; and

10 a controller which couples the drive for the cutter to the drive for the moving web transporting roller.

5. The cutting apparatus of claim 1, wherein the groove has a lateral edge and a catching device at one end of the groove, the lateral edge of the groove driving the  
15 cutter in the manner of a motion-transmitting screw thread.

FETHERSTONHAUGH & CO.

OTTAWA, CANADA

PATENT AGENTS

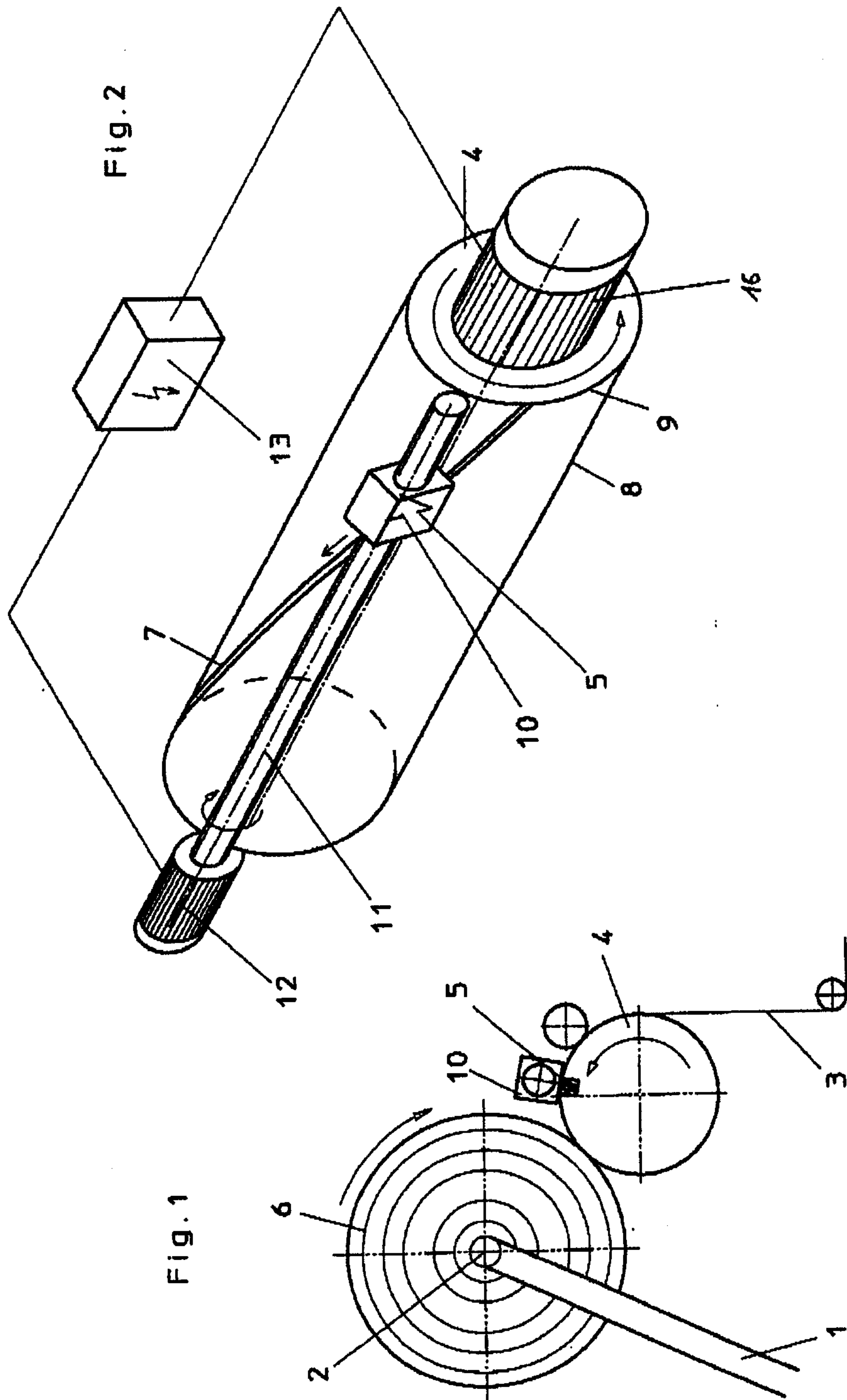

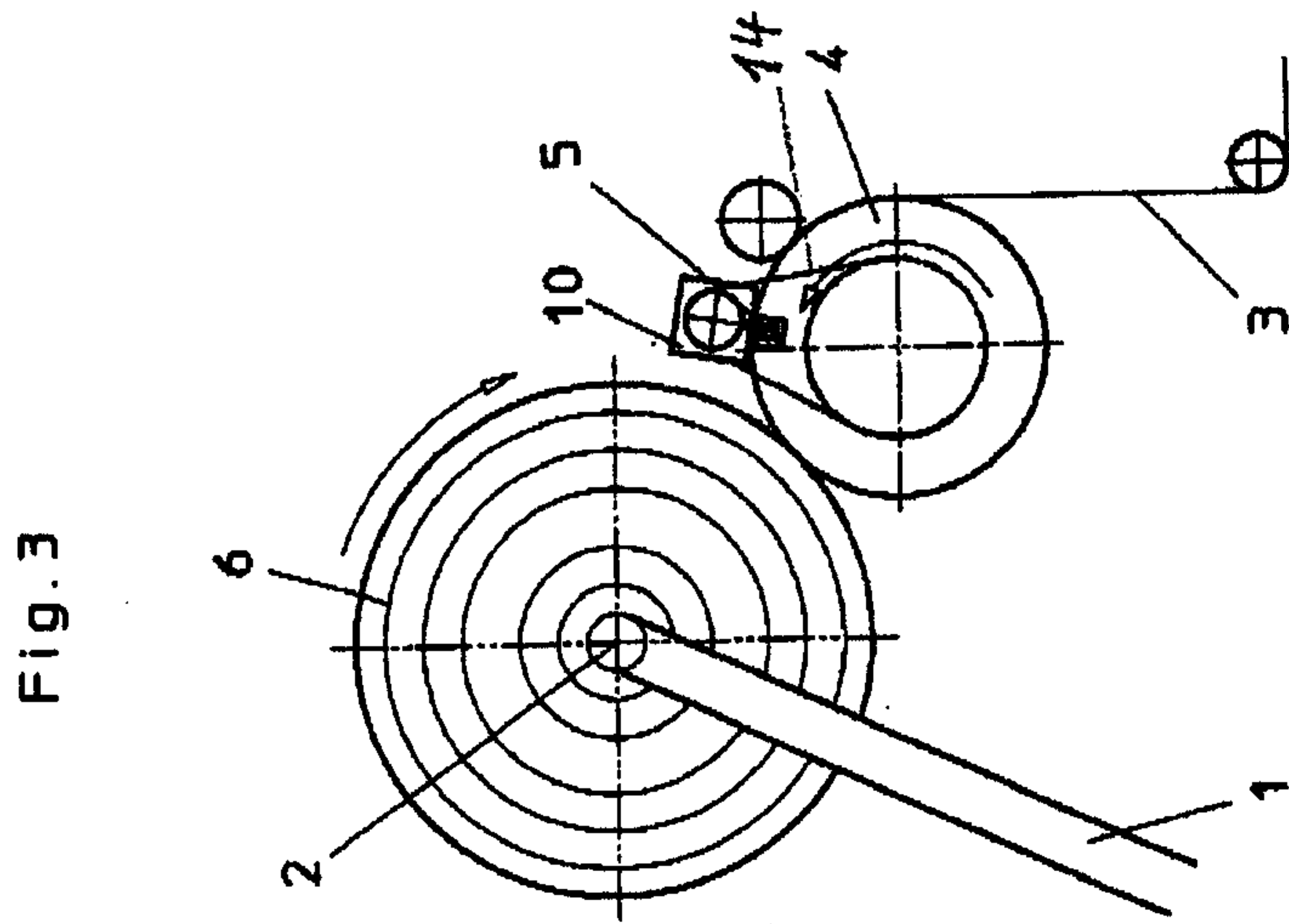
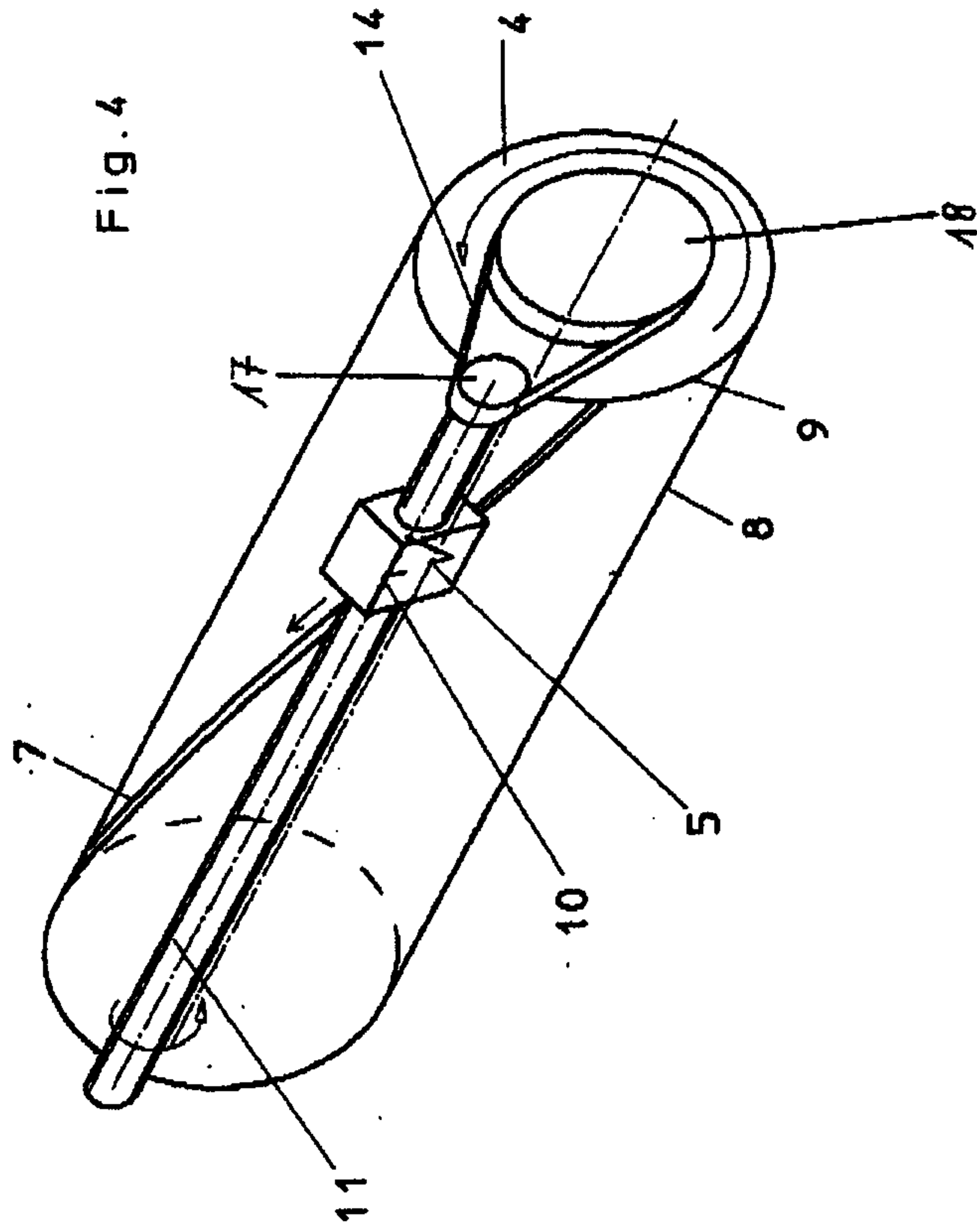

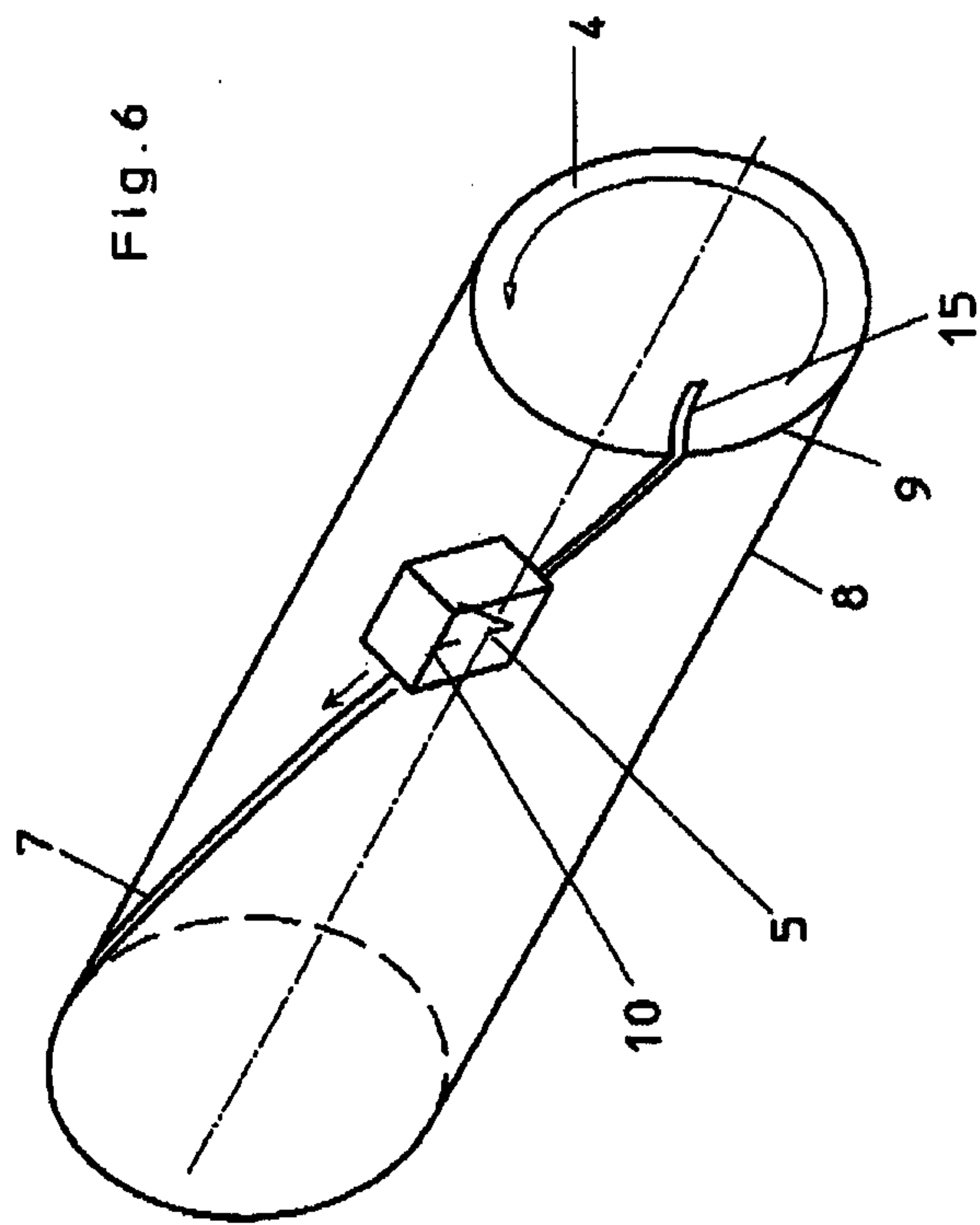

Fig. 5

