



US00RE49156E

(19) **United States**  
(12) **Reissued Patent**  
Case et al.

(10) **Patent Number:** **US RE49,156 E**  
(45) **Date of Reissued Patent:** **\*Aug. 2, 2022**

(54) **METHODS OF PROVIDING ELECTRICITY USED IN A FRACTURING OPERATION**

(56) **References Cited**

(71) Applicant: **Halliburton Energy Services, Inc.**,  
Houston, TX (US)

U.S. PATENT DOCUMENTS  
548,793 A 10/1895 Winship  
1,730,173 A 10/1929 Stearns  
(Continued)

(72) Inventors: **Leonard R. Case**, Duncan, OK (US);  
**Ed B. Hagan**, Hastings, OK (US);  
**Calvin L. Stegemoeller**, Sagerton, TX (US);  
**Ron Hyden**, Spring, TX (US)

FOREIGN PATENT DOCUMENTS

CN 1877079 A 12/2006  
DE 3717417 A1 12/1988  
(Continued)

(73) Assignee: **Halliburton Energy Services, Inc.**,  
Houston, TX (US)

OTHER PUBLICATIONS

(\* ) Notice: This patent is subject to a terminal disclaimer.

Tomlinson, H. L., A. C. Byrd, and C. F. VanBerg "Fracturing process control and automation." Permian Basin Oil and Gas Recovery Conference. Society of Petroleum Engineers, 1988.  
(Continued)

(21) Appl. No.: **17/221,242**

(22) Filed: **Apr. 2, 2021**

*Primary Examiner* — William C Doerler  
(74) *Attorney, Agent, or Firm* — John Wustenberg; Baker Botts L.L.P.

**Related U.S. Patent Documents**

Reissue of:

(64) Patent No.: **8,834,012**  
Issued: **Sep. 16, 2014**  
Appl. No.: **12/774,959**  
Filed: **May 6, 2010**

(57) **ABSTRACT**

Methods and systems for integral storage and blending of the materials used in oilfield operations are disclosed. A modular integrated material blending and storage system includes a first module comprising a storage unit, a second module comprising a liquid additive storage unit and a pump for maintaining pressure at an outlet of the liquid additive storage unit. The system further includes a third module comprising a pre-gel blender. An output of each of the first module, the second module and the third module is located above a blender and gravity directs the contents of the first module, the second module and the third module to the blender. The system also includes a pump that directs the output of the blender to a desired down hole location. The pump may be powered by natural gas or electricity.

U.S. Applications:

(60) Continuation of application No. 16/537,070, filed on Aug. 9, 2019, and a continuation of application No. (Continued)

(51) **Int. Cl.**  
**E21B 21/06** (2006.01)  
(52) **U.S. Cl.**  
CPC ..... **E21B 21/062** (2013.01)  
(58) **Field of Classification Search**  
CPC ..... **E21B 21/062**  
See application file for complete search history.

**22 Claims, 7 Drawing Sheets**

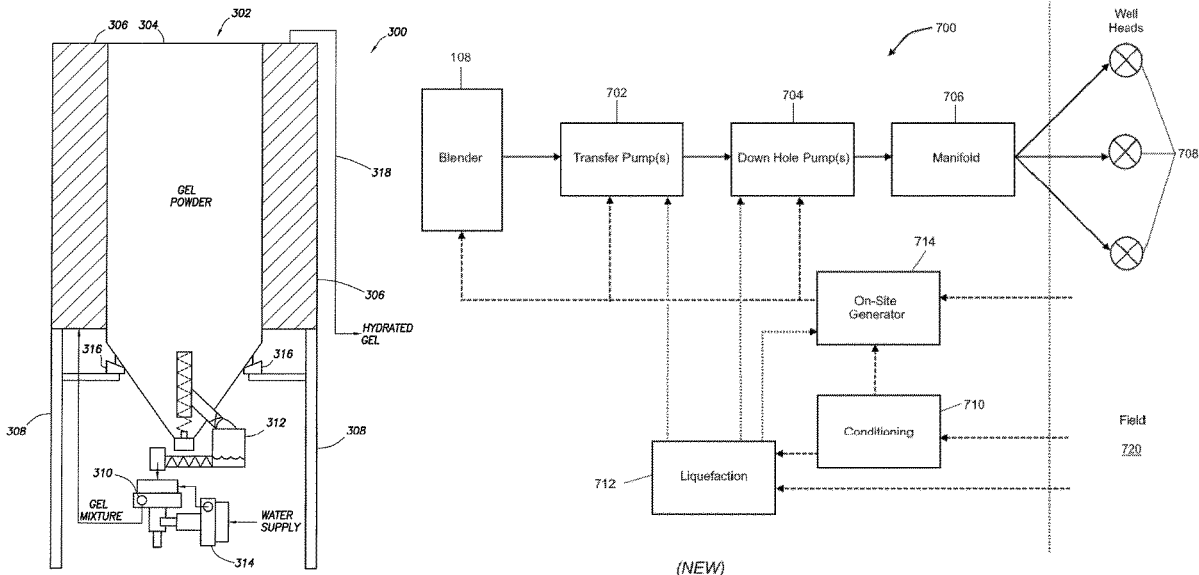

**Related U.S. Application Data**

16/537,124, filed on Aug. 9, 2019, which is a continuation of application No. 15/853,076, filed on Dec. 22, 2017, now Pat. No. Re. 47,695, which is a division of application No. 15/079,027, filed on Mar. 23, 2016, now Pat. No. Re. 46,725, which is an application for the reissue of Pat. No. 8,834,012, which is a continuation-in-part of application No. 12/557,730, filed on Sep. 11, 2009, now Pat. No. 8,444,312.

(56)

**References Cited**

U.S. PATENT DOCUMENTS

2,795,403 A	6/1957	Mead	5,769,058 A	6/1998	Scogin
2,821,854 A	2/1958	Franke	5,811,737 A	9/1998	Gaiski
3,155,248 A	11/1964	Haller	5,811,738 A	9/1998	Boyovich et al.
3,259,190 A	7/1966	Parsons	5,850,757 A	12/1998	Wierenga
3,279,550 A	10/1966	Kersten	5,880,410 A	3/1999	Neuman
3,291,234 A	12/1966	Woodburn	5,884,232 A	3/1999	Buder
3,381,943 A	5/1968	Miller	5,981,446 A	11/1999	Qiu et al.
3,547,291 A	12/1970	Batterton et al.	6,118,083 A	9/2000	Boyovich et al.
3,587,760 A	6/1971	Othmar et al.	6,148,667 A	11/2000	Johnson
3,591,147 A	7/1971	Anderson et al.	6,186,657 B1	2/2001	Fuchsbichler
3,687,319 A	8/1972	Adam et al.	6,242,701 B1	6/2001	Breed et al.
3,792,790 A	2/1974	Brubaker	6,284,987 B1	9/2001	Al-Modiny
3,854,540 A	12/1974	Holmstrom, Jr.	6,313,414 B1	11/2001	Campbell
3,857,452 A	12/1974	Hartman	6,384,349 B1	5/2002	Voll
3,893,655 A	7/1975	Sandiford	6,414,455 B1	7/2002	Watson
3,931,999 A	1/1976	McCain	6,474,926 B2	11/2002	Weiss
3,934,739 A	1/1976	Zumsteg et al.	6,495,774 B1	12/2002	Pederson
3,962,877 A	6/1976	Schiemichen	6,532,830 B1	3/2003	Jansen et al.
4,063,605 A	12/1977	Graham	6,601,763 B1	8/2003	Hoch et al.
4,103,752 A	8/1978	Schmidt	6,769,315 B2	8/2004	Stevenson et al.
4,163,626 A	8/1979	Batterton et al.	6,817,376 B2	11/2004	Morgan et al.
4,169,506 A	10/1979	Berry	6,928,886 B2	8/2005	Meusel et al.
4,187,047 A	2/1980	Squifflet	6,948,535 B2	9/2005	Stegemoeller
4,249,838 A	2/1981	Harvey et al.	7,048,432 B2	5/2006	Phillippi et al.
4,265,266 A	5/1981	Kierbow et al.	7,114,322 B2	10/2006	Yamanaka et al.
4,345,628 A	8/1982	Campbell et al.	7,202,425 B2	4/2007	Knudsen et al.
4,345,872 A	8/1982	Arnold	7,214,028 B2	5/2007	Boasso
4,411,327 A	10/1983	Lockery et al.	7,214,892 B2	5/2007	Williamson
4,465,420 A	8/1984	Dillman	7,240,549 B2	7/2007	Kimbara et al.
4,621,972 A	11/1986	Grotte	7,267,001 B1	9/2007	Stein
4,634,335 A	1/1987	Van Den Pol	7,353,875 B2	4/2008	Stephenson et al.
4,708,569 A	11/1987	Nijenhuis	7,472,542 B2	1/2009	Yamanaka et al.
4,726,435 A	2/1988	Kitagawa et al.	7,528,329 B2	5/2009	Nuyts
4,730,118 A	3/1988	Quarles et al.	7,836,949 B2	11/2010	Dykstra
4,775,275 A	10/1988	Perry	7,841,394 B2	11/2010	McNeel et al.
4,819,750 A	4/1989	Carnevale	7,946,340 B2	5/2011	Surjaatmadja et al.
4,844,189 A	7/1989	Shisgal et al.	8,146,665 B2	4/2012	Neal
4,850,750 A	7/1989	Cogbill et al.	8,444,312 B2*	5/2013	Hagan
4,854,714 A	8/1989	Davis	2001/0038018 A1	11/2001	Bell et al.
4,898,473 A	2/1990	Stegemoeller et al.	2003/0047387 A1	3/2003	Bogat
4,913,198 A	4/1990	Hayahara et al.	2003/0047603 A1	3/2003	Lustenberger et al.
5,016,666 A	5/1991	McKinney et al.	2003/0117890 A1	6/2003	Dearing et al.
5,044,861 A	9/1991	Kirchhoff et al.	2003/0202869 A1	10/2003	Posch
5,127,450 A	7/1992	Saatkamp	2004/0008571 A1	1/2004	Coody et al.
5,133,212 A	7/1992	Grills et al.	2004/0011523 A1	1/2004	Sarada
5,161,628 A	11/1992	Wirth	2005/0110648 A1	5/2005	Lehrman et al.
5,205,370 A	4/1993	Paul et al.	2005/0155667 A1	7/2005	Stegemoeller
5,318,382 A	6/1994	Cahill	2006/0015414 A1	1/2006	Congram et al.
5,333,695 A	8/1994	Walter	2006/0225924 A1	10/2006	Ivan et al.
5,343,000 A	8/1994	Griffen et al.	2007/0107540 A1	5/2007	Davies
5,452,615 A	9/1995	Hilton	2007/0120367 A1	5/2007	Scherzer
5,452,954 A	9/1995	Handke et al.	2007/0125543 A1	6/2007	McNeel et al.
5,546,683 A	8/1996	Clark	2007/0125544 A1	6/2007	Robinson et al.
5,578,798 A	11/1996	Nuyts	2007/0201305 A1	8/2007	Heilman et al.
5,606,853 A	3/1997	Birch et al.	2007/0277982 A1	12/2007	Shampine et al.
5,635,680 A	6/1997	Dojan	2008/0017369 A1	1/2008	Sarada
5,637,837 A	6/1997	Merz et al.	2008/0029267 A1	2/2008	Shampine et al.
5,665,910 A	9/1997	Knutson et al.	2008/0066911 A1	3/2008	Luharuka et al.
5,717,167 A	2/1998	Filing et al.	2008/0135238 A1	6/2008	Cugnet et al.
5,752,768 A	5/1998	Assh	2008/0165613 A1	7/2008	Dykstra
5,764,522 A	6/1998	Shalev	2008/0173480 A1	7/2008	Annaiyappa et al.
			2008/0203734 A1	8/2008	Grimes et al.
			2008/0238101 A1	10/2008	Ziegenfuss
			2008/0264625 A1	10/2008	Ochoa
			2008/0264641 A1	10/2008	Slabaugh et al.
			2008/0271927 A1	11/2008	Crain
			2009/0068031 A1	3/2009	Gambier et al.
			2009/0078410 A1	3/2009	Krenek et al.
			2009/0090504 A1	4/2009	Weightman
			2009/0095482 A1	4/2009	Surjaatmadja
			2009/0107734 A1	4/2009	Lucas
			2009/0178387 A1	7/2009	Schultz et al.
			2009/0301725 A1	12/2009	Case et al.
			2010/0018710 A1	1/2010	Leshchyshyn et al.
			2010/0038907 A1	2/2010	Hunt et al.
			2010/0071284 A1	3/2010	Hagan et al.
			2010/0071899 A1	3/2010	Coquilleau et al.

(56)

References Cited

U.S. PATENT DOCUMENTS

2011/0197988 A1 8/2011 Van Vliet et al.  
2012/0157356 A1 6/2012 Dawson et al.

FOREIGN PATENT DOCUMENTS

DE	29518215	U1	5/1996
EP	0605113	A1	7/1994
EP	A 0 605 113	A1	7/1994
FR	2474335		7/1981
FR	2474335	A1	7/1981
GB	PCT/GB2009/001675		2/2011
WO	1994019263	A1	9/1994
WO	WO 94/19263		9/1994
WO	2007113528	A1	10/2007
WO	WO 2007/113528	A1	10/2007
WO	2009065858	A1	5/2009
WO	WO 2009/065858		5/2009

OTHER PUBLICATIONS

Stephenson, S. V., et al. "Fracturing process control and automation: Phase 2." Petroleum Computer Conference. Society of Petroleum Engineers, 1993.

Purvis, D. L., R. J. Novotny, and B. T. Carlson. "Field-Applied Computerized Tracking System: A Practical Approach to On-Site Quality Control." SPE Computer Applications 3.05 (1991): 22-28. Invalidation Chart, Mud Pump and Associated Materials HHUS Sold to Nabors, *U.S. Well Services, LLC v. TOPS Well Services, LLC et al.*, Case 3:19-cv-00237, D.I. 76-13 (S.D. Tex.), Apr. 29, 2020, 135 pages.

"The Jet Frac Revolution," Turbine Stimulation Technologies, BIC Magazine, Apr. 2006, 3 pages.

Archive of MTT Website, available at <https://web.archive.org/web/20090615185330/marineturbine.com/frac.asp>, Jun. 15, 2009, 3 pages. Excerpts from manual related to Halliburton Stim Star vessel, admitted as prior art, 7 pages.

1966 Halliburton Sales and Service Catalog, 3 pages.

"Hydraulic Fracturing and Flowback Hazards Other than Respirable Silica." Occupational Safety and Health Administration, OSHA 3763-12 2014, 2014, 27 pages.

Occupational Safety and Health Administration. "Hazard alert: Worker exposure to silica during hydraulic fracturing." Retrieved from [http://www.osha.gov/dts/hazardalerts/hydraulic\\_frac\\_hazard\\_alert.html](http://www.osha.gov/dts/hazardalerts/hydraulic_frac_hazard_alert.html) (2012), 7 pages.

"Auxiliary Pump Plants," Halliburton Special Services, dated May 24, 2000.

"2,400 Hydraulic Horsepower Electric Pump Plant With All Support Equipment," Halliburton Special Services, dated May 24, 2000.

"Electric Pumping Equipment SCR Drive," Pumping Equipment Data Book Manual No. 277.17165, Halliburton Services, Section 17, pp. 187-194, dated Sep. 1980.

Takacs, Gabor. Chapter 1—Electrical Submersible Pumps Manual: Design, Operations, and Maintenance. Gulf Professional Publishing, Mar. 2009, 8 pages.

Railroad Commission of Texas, Injection / Disposal Well: Permitting, Testing, and Monitoring Manual, Summary of Standards and Procedures, Technical Review at Section 6 ("Injection Pressure Requirements"), available at <https://www.rrc.texas.gov/oil-and-gas/publications-and-notice/manuals/injection-disposal-well-manual/summary-of-standards-and-procedures/technical-review/>, accessed Jan. 24, 2022, 15 pages.

Declaration of Harold E. McGowen III, PE, Pursuant to 37 C.F.R. § 1.132, dated Jan. 24, 2022, 16 pages.

U.S. Pat. No. 548,793, issued Oct. 29, 1895 to James H. Winship for "Rendering Apparatus".

Office Action in U.S. Appl. No. 12/422,450 dated Jun. 18, 2010.

"Truck-Back Turbines", Machine Design, vol. 32, No. 5, Mar. 3, 1960, p. 12, 3 pages.

Boerger pump—available at: [http://www.boerger-pumps.com/contero/gallery/Prospekte\\_USA/us\\_p\\_ssr\\_boerger\\_powerfeed\\_0309.pdf](http://www.boerger-pumps.com/contero/gallery/Prospekte_USA/us_p_ssr_boerger_powerfeed_0309.pdf).

Office Action in U.S. Appl. No. 11/741,509, Aug. 19, 2009.

Office Action in U.S. Appl. No. 11/741,509, Jan. 28, 2010.

Office Action in U.S. Appl. No. 11/930,756, Mar. 18, 2009.

Office Action in U.S. Appl. No. 11/930,756, Jul. 7, 2009.

Office Action in U.S. Appl. No. 11/930,756, Jan. 28, 2010.

Advisory Action in U.S. Appl. No. 11/930,756, Mar. 31, 2010.

International Search Report and Written Opinion issued in PCT/GB2011/000678 mailed on Oct. 12, 2012.

Office Action in U.S. Appl. No. 12/422,450, Jun. 18, 2010.

Office Action in U.S. Appl. No. 12/435,551, Jun. 15, 2011.

Office Action from U.S. Appl. No. 11/930,756, dated May 27, 2010.

International Search Report for Application No. PCT/GB2010/000512, Jun. 25, 2010.

Office Action in U.S. Appl. No. 12/635,009, Jul. 23, 2012.

Fenna et al., "Dictionary of Weights, Measures, and Units," Oxford University Press, 2002, pp. I, 65 and 66, 2002.

Kutz et al., "Mechanical Engineers' Handbook," 2nd Ed., 1998, pp. I, II, and 1332, 1998.

Abulnaga, "Slurry Systems Handbook," 2002, pp. I, II, and 1.20, 2002.

International Preliminary Report on Patentability in PCT/GB2009/001675 issued Feb. 1, 2011.

Office Action issued in Canadian Application No. 2, 731, 840 on Jul. 25, 2012.

Office Action issued in U.S. Appl. No. 12/235,270, Mar. 4, 2011.

International Search Report in PCT/GB2010/001717, May 10, 2011.

Office Action in U.S. Appl. No. 12/182,297, Apr. 21, 2011.

\* cited by examiner

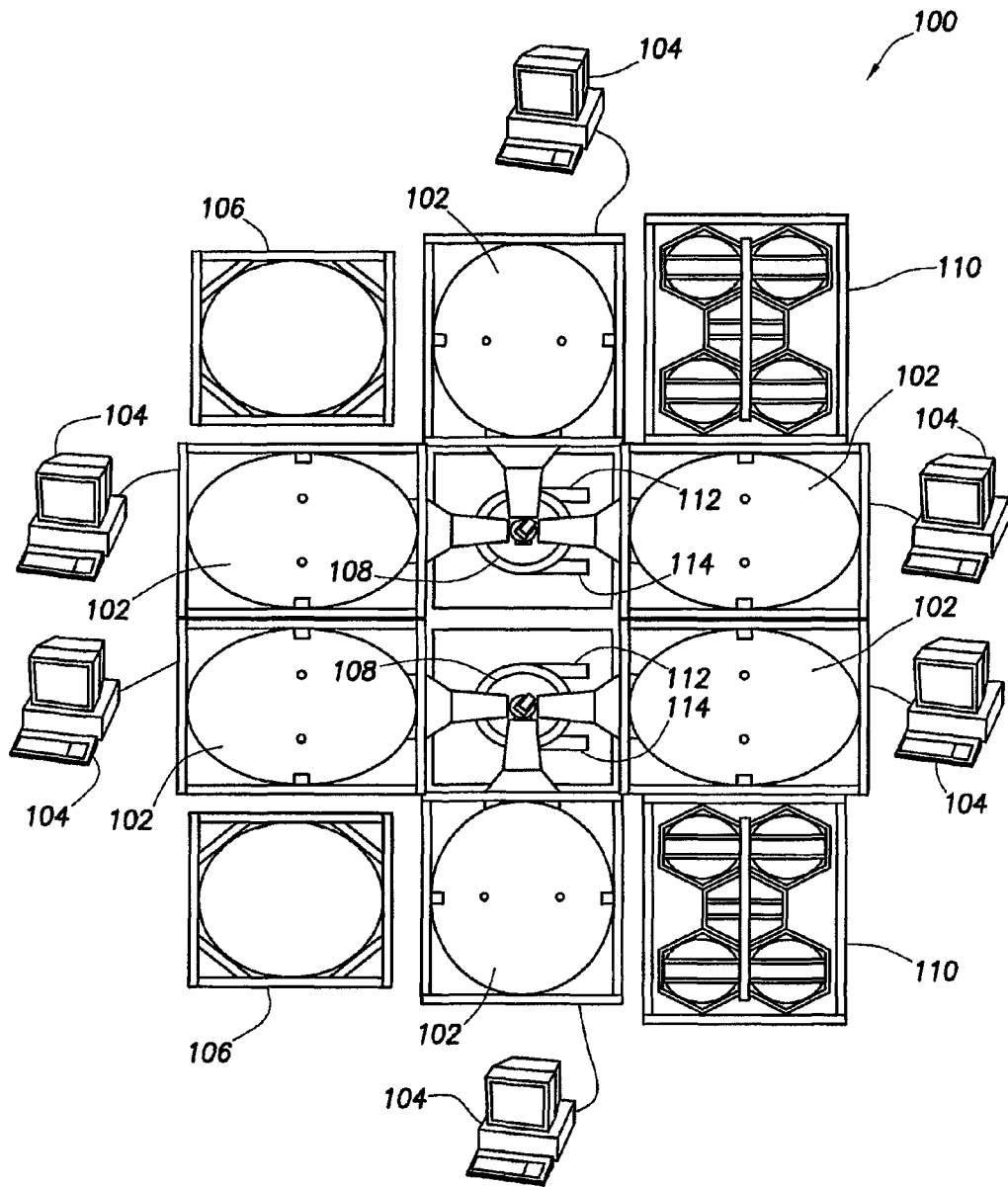

FIG. 1

FIG.2

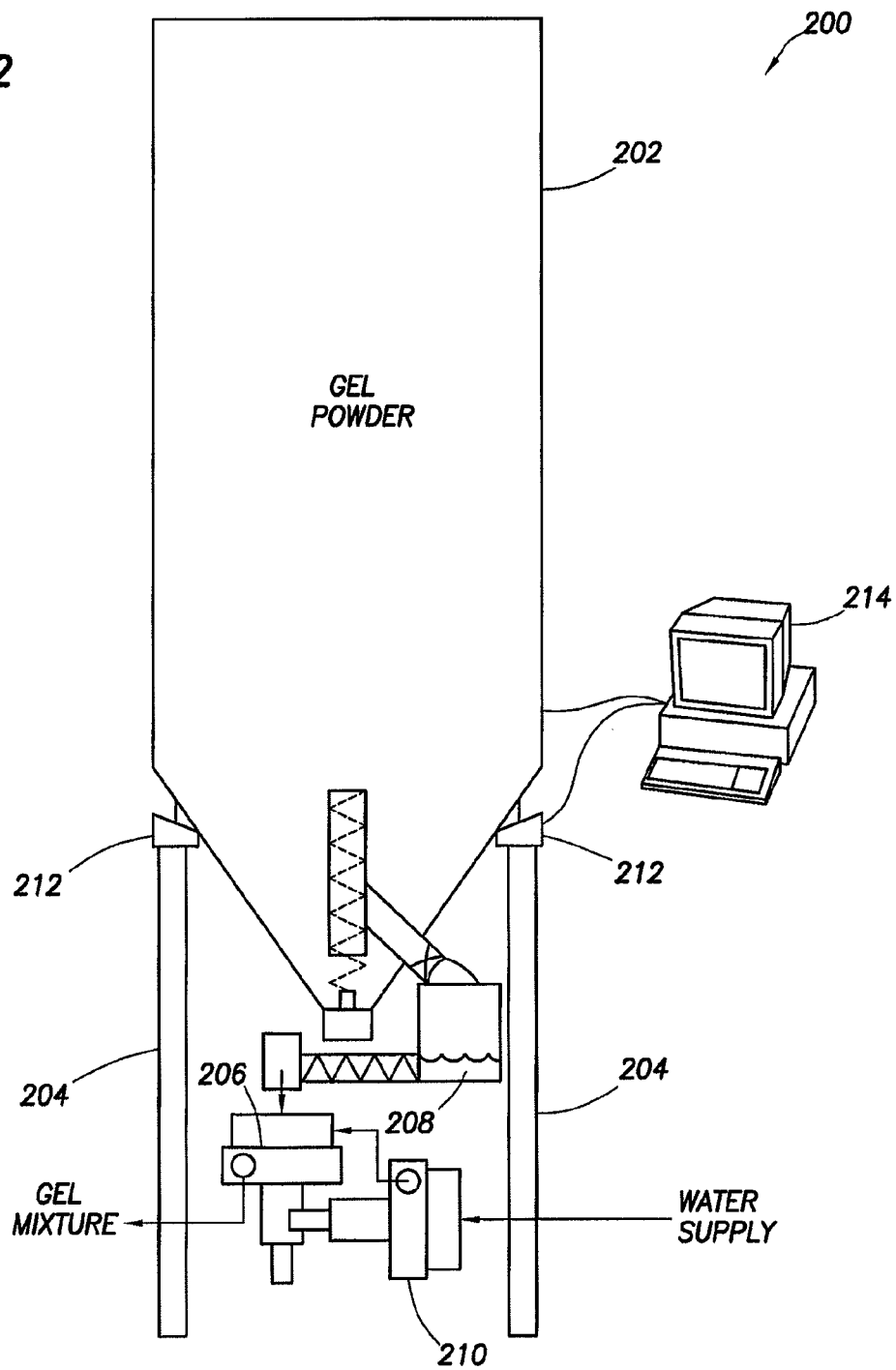

FIG. 3

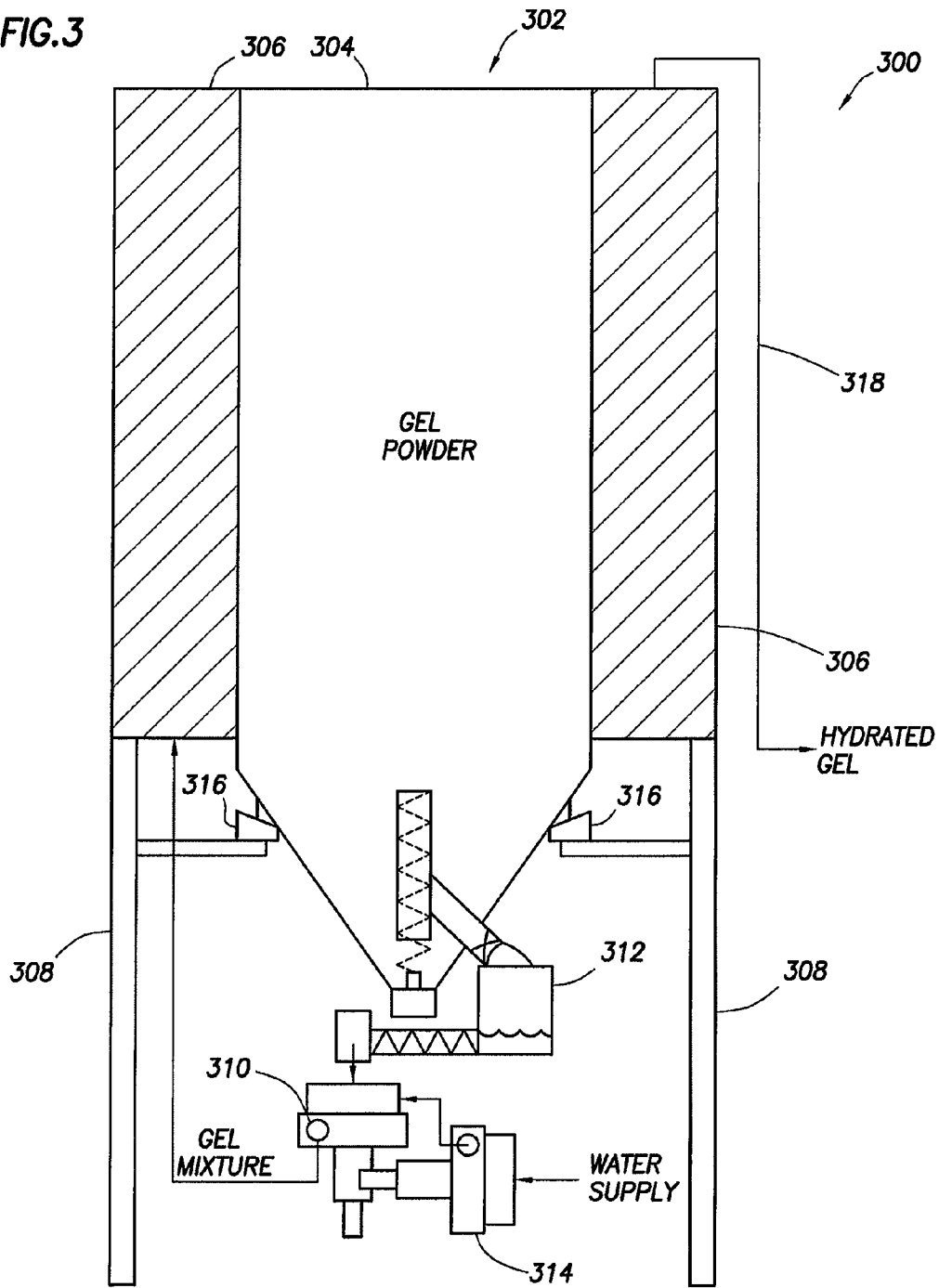
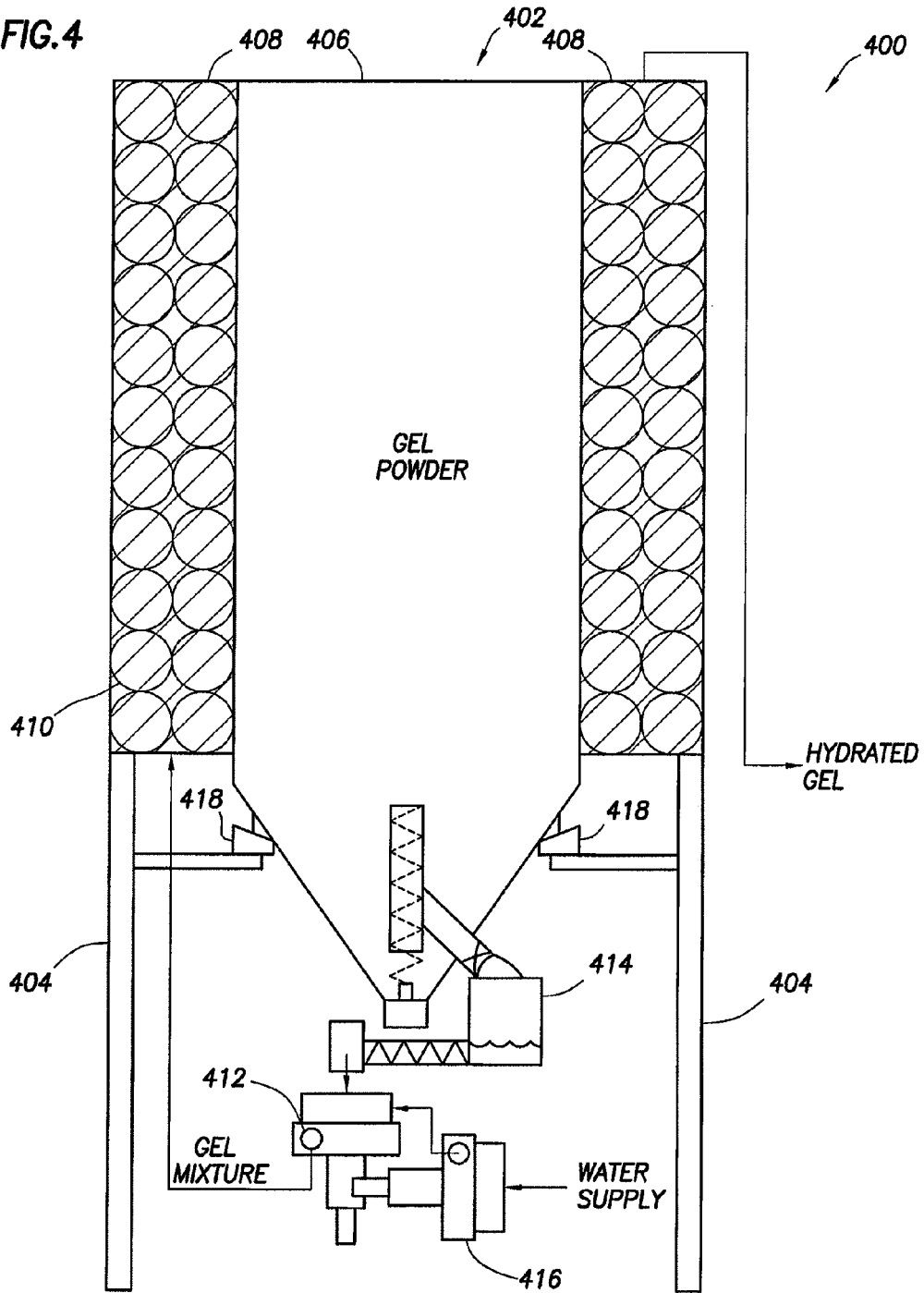

FIG. 4



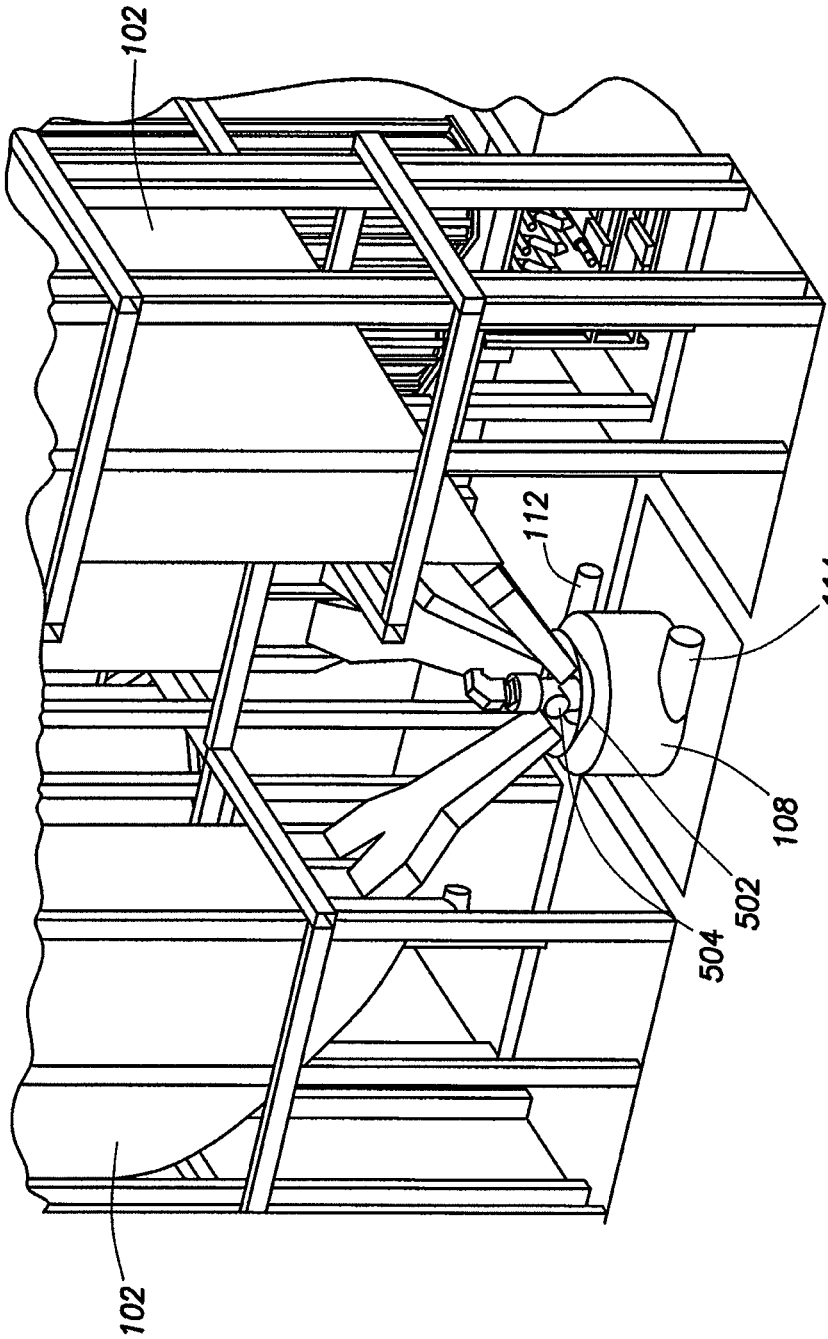

FIG. 5



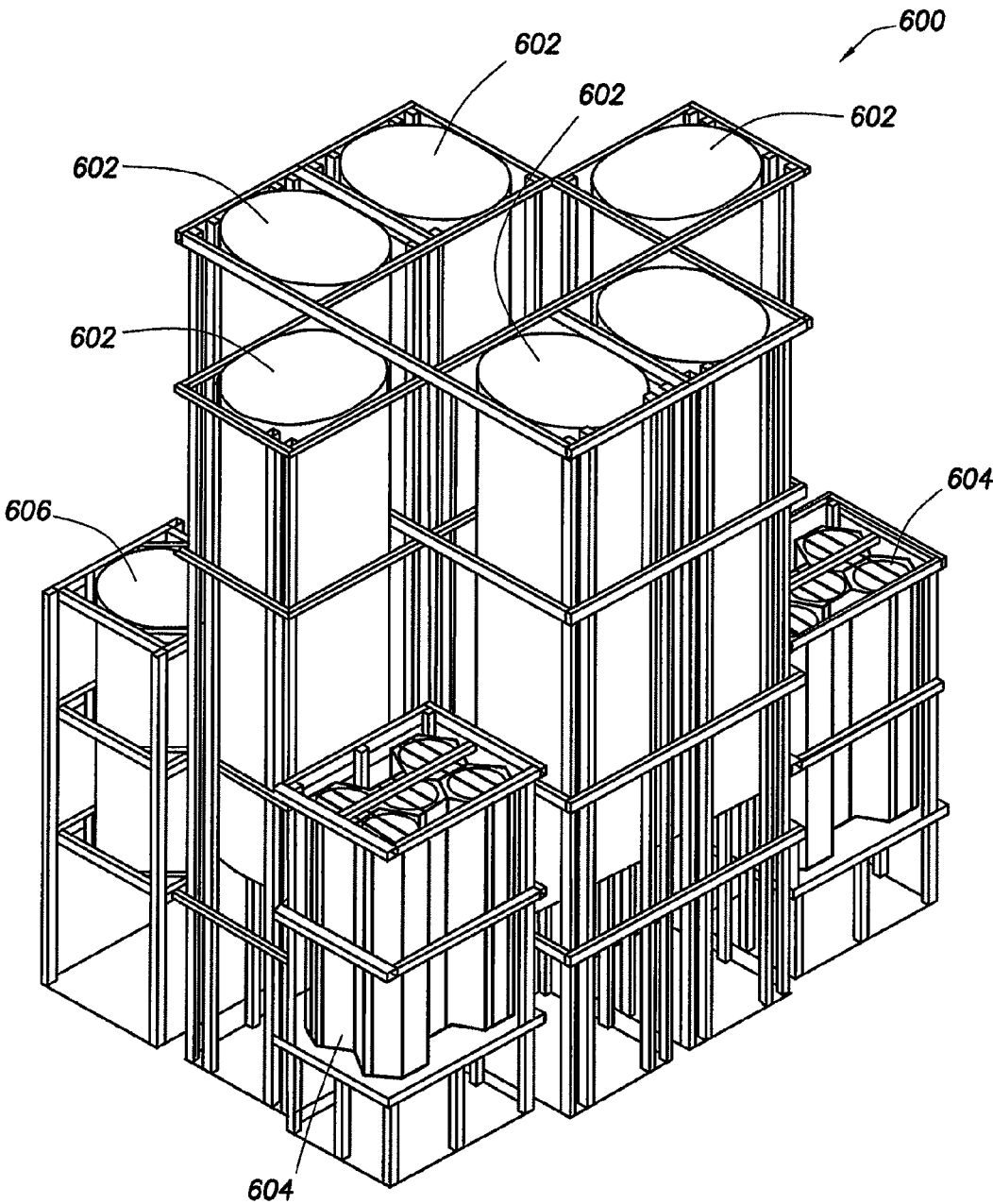
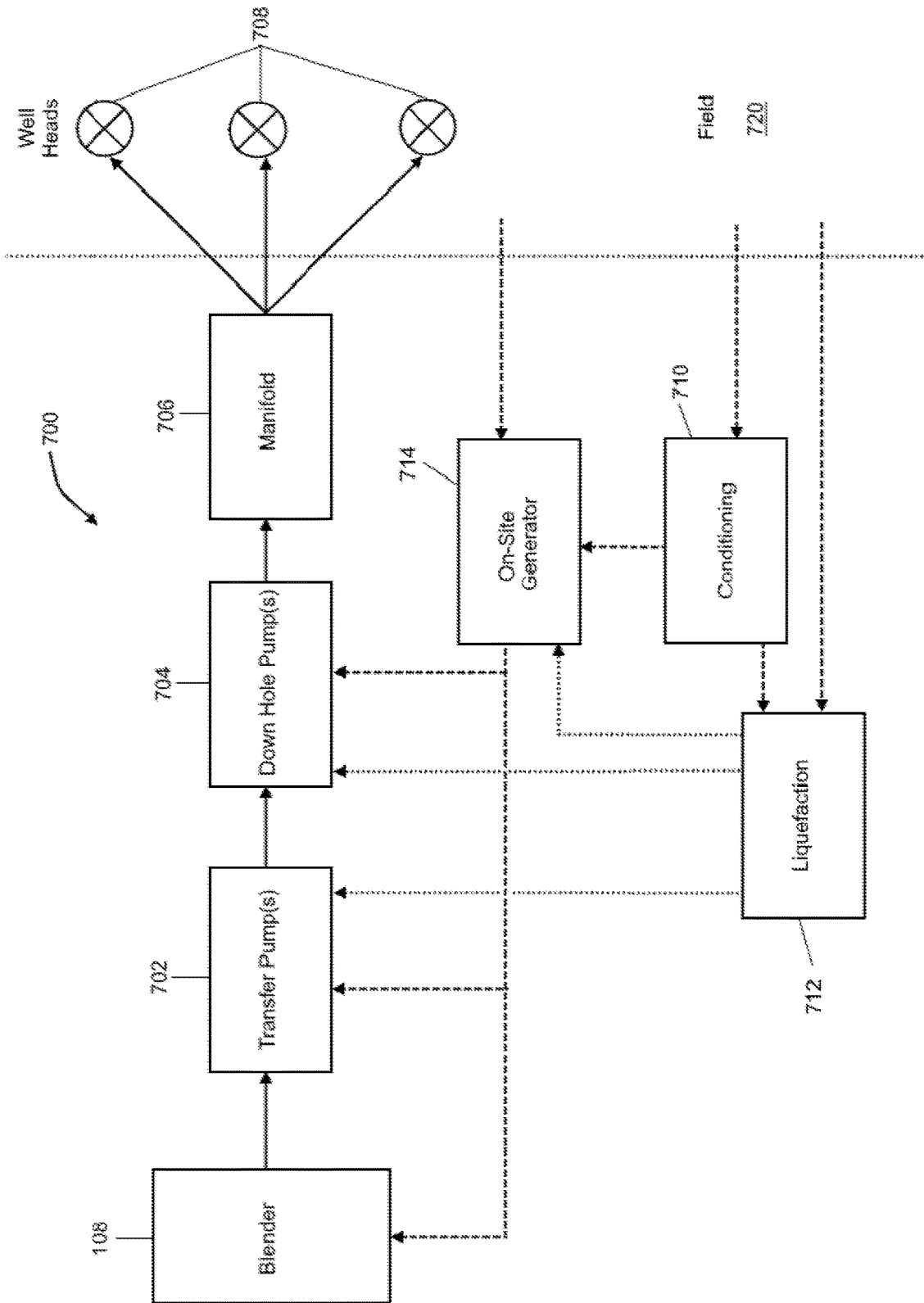

FIG. 6



(NEW) FIG. 7

## METHODS OF PROVIDING ELECTRICITY USED IN A FRACTURING OPERATION

**Matter enclosed in heavy brackets [ ] appears in the original patent but forms no part of this reissue specification; matter printed in italics indicates the additions made by reissue; a claim printed with strikethrough indicates that the claim was canceled, disclaimed, or held invalid by a prior post-patent action or proceeding.**

*Notice: More than one reissue application has been filed for the reissue of U.S. Pat. No. 8,834,012. The reissue applications are U.S. patent application Ser. No. 15/079,027, now U.S. Pat. No. RE46,725, which is a reissue application of U.S. Pat. No. 8,834,012; U.S. patent application Ser. No. 15/853,076, now U.S. Pat. No. RE47,695, which is a divisional reissue application of U.S. patent application Ser. No. 15/079,027, now U.S. Pat. No. RE46,725; U.S. patent application Ser. No. 16/537,070, which is a continuation reissue application of U.S. patent application Ser. No. 15/853,076, now U.S. Pat. No. RE47,695; U.S. patent application Ser. No. 16/537,124, which is a continuation reissue application of U.S. patent application Ser. No. 15/853,076 now U.S. Pat. No. RE47,695; the present U.S. patent application Ser. No. 17/221,242, which is a continuation reissue application of U.S. patent application Ser. No. 16/537,070 and the following co-pending U.S. patent applications Ser. Nos. 17/221,152, 17/221,176, 17/221,186, 17/221,204, 17/221,221, 17/221,267, 17/221,281, 17/221,317, 17/352,956, and 17/353,091, each of which is a continuation reissue application of U.S. patent application Ser. Nos. 16/537,070 and 16/537,124 and a reissue of U.S. Pat. No. 8,843,012.*

### CROSS REFERENCE TO RELATED APPLICATIONS

[This application is a continuation-in-part of U.S. patent application Ser. No. 12/557,730, filed Sep. 11, 2009, now U.S. Pat. No. 8,444,312 entitled "Improved Methods and Systems for Integral Blending and Storage of Materials," the entire disclosure of which is incorporated herein by reference.]*This application is a continuation reissue of U.S. patent application Ser. No. 16/537,070 and U.S. patent application Ser. No. 16/537,124, both filed on Aug. 9, 2019, which are reissue applications of U.S. Pat. No. 8,834,012 and continuation reissue applications of U.S. patent application Ser. No. 15/853,076, filed on Dec. 22, 2017, now U.S. Pat. No. RE47,695, which is a reissue of U.S. Pat. No. 8,834,012 and a divisional reissue application of U.S. patent application Ser. No. 15/079,027, filed on Mar. 23, 2016, now U.S. Pat. No. RE46,725, which is a reissue of U.S. patent application Ser. No. 12/744,959, filed on May 6, 2010, now U.S. Pat. No. 8,834,012, issued on Sep. 16, 2014, entitled "Electric or Natural Gas Fired Small Footprint Fracturing Fluid Blending and Pumping Equipment," which is a continuation-in-part of U.S. patent application Ser. No. 12/557,730, filed Sep. 11, 2009, now U.S. Patent No. 8,444,312, issued on May 21, 2013, entitled "Improved Methods and Systems for Integral Blending and Storage of Materials," the entire disclosures of which are incorporated herein by reference.*

### BACKGROUND

The present invention relates generally to oilfield operations, and more particularly, to methods and systems for integral storage and blending of the materials used in oilfield operations.

Oilfield operations are conducted in a variety of different locations and involve a number of equipments, depending on the operations at hand. The requisite materials for the different operations are often hauled to and stored at the well site where the operations are to be performed.

Considering the number of equipments necessary for performing oilfield operations and ground conditions at different oilfield locations, space availability is often a constraint. For instance, in well treatment operations such as fracturing operations, several wells may be serviced from a common jobsite pad. In such operations, the necessary equipment is not moved from well site to well site. Instead, the equipment may be located at a central work pad and the required treating fluids may be pumped to the different well sites from this central location. Accordingly, the bulk of materials required at a centralized work pad may be enormous, further limiting space availability.

Typically, in modern well treatment operations, equipment is mounted on a truck or a trailer and brought to location and set up. The storage units used are filled with the material required to prepare the well treatment fluid and perform the well treatment. In order to prepare the well treatment fluid, the material used is then transferred from the storage units to one or more blenders to prepare the desired well treatment fluid which may then be pumped down hole.

For instance, in conventional fracturing operations a blender and a pre-gel blender are set between the high pressure pumping units and the storage units which contain the dry materials and chemicals used. The dry materials and the chemicals used in the fracturing operations are then transferred, often over a long distance, from the storage units to the mixing and blending equipments. Once the treating process is initiated, the solid materials and chemicals are typically conveyed to the blender by a combination of conveyer belts, screw type conveyers and a series of hoses and pumps.

The equipment used for transferring the dry materials and chemicals from the storage units to the blender occupy valuable space at the job site. Additionally, the transfer of dry materials and chemicals to the blender consumes a significant amount of energy as well as other system resources and contributes to the carbon foot print of the job site. Moreover, in typical "on land" operations the entire equipment spread including the high horsepower pumping units are powered by diesel fired engines and the bulk material metering, conveying and pumping is done with diesel fired hydraulic systems. Emissions from the equipment that is powered by diesel fuel contributes to the overall carbon footprint and adversely affects the environment.

### FIGURES

Some specific example embodiments of the disclosure may be understood by referring, in part, to the following description and the accompanying drawings.

FIG. 1 is a top view of an Integrated Material Storage and Blending System in accordance with an exemplary embodiment of the present invention.

FIG. 2 is a cross sectional view of an Integrated Pre-gel Blender in accordance with a first exemplary embodiment of the present invention.

FIG. 3 is a cross sectional view of an Integrated Pre-gel Blender in accordance with a second exemplary embodiment of the present invention.

FIG. 4 is a cross sectional view of an Integrated Pre-gel Blender in accordance with a third exemplary embodiment of the present invention.

FIG. 5 depicts a close up view of the interface between the storage units and a blender in an Integrated Material Storage and Blending System in accordance with an exemplary embodiment of the present invention.

FIG. 6 is an isometric view of an Integrated Material Storage and Blending System in accordance with an exemplary embodiment of the present invention.

FIG. 7 is a diagram illustrating a pumping system in accordance with an exemplary embodiment of the present invention.

While embodiments of this disclosure have been depicted and described and are defined by reference to example embodiments of the disclosure, such references do not imply a limitation on the disclosure, and no such limitation is to be inferred. The subject matter disclosed is capable of considerable modification, alteration, and equivalents in form and function, as will occur to those skilled in the pertinent art and having the benefit of this disclosure. The depicted and described embodiments of this disclosure are examples only, and not exhaustive of the scope of the disclosure.

### SUMMARY

The present invention relates generally to oilfield operations, and more particularly, to methods and systems for integral storage and blending of the materials used in oilfield operations.

In one embodiment, the present invention is directed to an integrated material blending and storage system comprising: a storage unit; a blender located under the storage unit; wherein the blender is operable to receive a first input from the storage unit; a liquid additive storage module having a pump to maintain constant pressure at an outlet of the liquid additive storage module; wherein the blender is operable to receive a second input from the liquid additive storage module; and a pre-gel blender; wherein the blender is operable to receive a third input from the pre-gel blender; wherein gravity directs the contents of the storage unit, the liquid additive storage module and the pre-gel blender to the blender; a first pump; and a second pump; wherein the first pump directs the contents of the blender to the second pump; and wherein the second pump directs the contents of the blender down hole; wherein at least one of the first pump and the second pump is powered by one of natural gas and electricity.

In another exemplary embodiment, the present invention is directed to a modular integrated material blending and storage system comprising: a first module comprising a storage unit; a second module comprising a liquid additive storage unit and a pump for maintaining pressure at an outlet of the liquid additive storage unit; and a third module comprising a pre-gel blender; wherein an output of each of the first module, the second module and the third module is located above a blender; and wherein gravity directs the contents of the first module, the second module and the third module to the blender; a pump; wherein the pump directs the output of the blender to a desired down hole location; and wherein the pump is powered by one of natural gas and electricity.

The features and advantages of the present disclosure will be readily apparent to those skilled in the art upon a reading of the description of exemplary embodiments, which follows.

### DESCRIPTION

The present invention relates generally to oilfield operations, and more particularly, to methods and systems for integral storage and blending of the materials used in oilfield operations.

Turning now to FIG. 1, an Integrated Material Storage and Blending System (IMSBS) in accordance with an exemplary embodiment of the present invention is depicted generally with reference numeral 100. The IMSBS 100 includes a number of storage units 102. The storage units 102 may contain sand, proppants or other solid materials used to prepare a desired well treatment fluid.

In one exemplary embodiment, the storage units 102 may be connected to load sensors (not shown) to monitor the reaction forces at the legs of the storage units 102. The load sensor readings may then be used to monitor the change in weight, mass and/or volume of materials in the storage units 102. The change in weight, mass or volume can be used to control the metering of material from the storage units 102 during well treatment operations. As a result, the load sensors may be used to ensure the availability of materials during oilfield operations. In one exemplary embodiment, load cells may be used as load sensors. Electronic load cells are preferred for their accuracy and are well known in the art, but other types of force-measuring devices may be used. As will be apparent to one skilled in the art, however, any type of load-sensing device can be used in place of or in conjunction with a load cell. Examples of suitable load-measuring devices include weight-, mass-, pressure- or force-measuring devices such as hydraulic load cells, scales, load pins, dual shear beam load cells, strain gauges and pressure transducers. Standard load cells are available in various ranges such as 0-5000 pounds, 0-10000 pounds, etc.

In one exemplary embodiment the load sensors may be communicatively coupled to an information handling system 104 which may process the load sensor readings. While FIG. 1 depicts a separate information handling system 104 for each storage unit 102, as would be appreciated by those of ordinary skill in the art, with the benefit of this disclosure, a single information handling system may be used for all or any combination of the storage units 102. Although FIG. 1 depicts a personal computer as the information handling system 104, as would be apparent to those of ordinary skill in the art, with the benefit of this disclosure, the information handling system 104 may include any instrumentality or aggregate of instrumentalities operable to compute, classify, process, transmit, receive, retrieve, originate, switch, store, display, manifest, detect, record, reproduce, handle, or utilize any form of information, intelligence, or data for business, scientific, control, or other purposes. For example, the information handling system 104 may be a network storage device, or any other suitable device and may vary in size, shape, performance, functionality, and price. For instance, in one exemplary embodiment, the information handling system 104 may be used to monitor the amount of materials in the storage units 102 over time and/or alert a user when the contents of a storage unit 102 reaches a threshold level. The user may designate a desired sampling interval at which the information handling system 104 may take a reading of the load sensors.

The information handling system 104 may then compare the load sensor readings to the threshold value to determine if the threshold value is reached. If the threshold value is reached, the information handling system 104 may alert the user. In one embodiment, the information handling system 104 may provide a real-time visual depiction of the amount of materials contained in the storage units 102. Moreover, as would be appreciated by those of ordinary skill in the art, with the benefit of this disclosure, the load sensors may be coupled to the information handling system 104 through a wired or wireless (not shown) connection.

5

As depicted in FIG. 1, the IMSBS 100 may also include one or more Integrated Pre-gel Blenders (IPB) 106. The IPB 106 may be used for preparing any desirable well treatment fluids such as a fracturing fluid, a sand control fluid or any other fluid requiring hydration time.

FIG. 2 depicts an IPB 200 in accordance with an exemplary embodiment of the present invention. The IPB 200 comprises a pre-gel storage unit 202 resting on legs 204. As would be appreciated by those of ordinary skill in the art, the pre-gel storage unit 202 may be a storage bin, a tank, or any other desirable storage unit. The pre-gel storage unit 202 may contain the gel powder used for preparing the gelled fracturing fluid. As would be appreciated by those of ordinary skill in the art, with the benefit of this disclosure, the gel powder may comprise a dry polymer. Specifically, the dry polymer may be any agent used to enhance fluid properties, including, but not limited to, wg18, wg35, wg36 (available from Halliburton Energy Services of Duncan, Okla.) or any other guar or modified guar gelling agents. The materials from the pre-gel storage unit 202 may be directed to a mixer 206 as a first input through a feeder 208. As would be appreciated by those of ordinary skill in the art, with the benefit of this disclosure, in one embodiment, the mixer 206 may be a growler mixer and the feeder 208 may be a screw feeder which may be used to provide a volumetric metering of the materials directed to the mixer 206. A water pump 210 may be used to supply water to the mixer 206 as a second input. A variety of different pumps may be used as the water pump 210 depending on the user preferences. For instance, the water pump 210 may be a centrifugal pump, a progressive cavity pump, a gear pump or a peristaltic pump. The mixer 206 mixes the gel powder from the pre-gel storage unit 202 with the water from the water pump 210 at the desired concentration and the finished gel is discharged from the mixer 206 and may be directed to a storage unit, such as an external frac tank (not shown), for hydration. The finished gel may then be directed to a blender 108 in the IMSBS 100.

In one exemplary embodiment, the legs 204 of the pre-gel storage unit 202 are attached to load sensors 212 to monitor the reaction forces at the legs 204. The load sensor 212 readings may then be used to monitor the change in weight, mass and/or volume of materials in the pre-gel storage unit 202. The change in weight, mass or volume can be used to control the metering of material from the pre-gel storage unit 202 at a given set point. As a result, the load sensors 212 may be used to ensure the availability of materials during oilfield operations. In one exemplary embodiment, load cells may be used as load sensors 212. Electronic load cells are preferred for their accuracy and are well known in the art, but other types of force-measuring devices may be used. As will be apparent to one skilled in the art, however, any type of load-sensing device can be used in place of or in conjunction with a load cell. Examples of suitable load-measuring devices include weight-, mass-, pressure- or force-measuring devices such as hydraulic load cells, scales, load pins, dual shear beam load cells, strain gauges and pressure transducers. Standard load cells are available in various ranges such as 0-5000 pounds, 0-10000 pounds, etc.

In one exemplary embodiment the load sensors 212 may be communicatively coupled to an information handling system 214 which may process the load sensor readings. Although FIG. 2 depicts a personal computer as the information handling system 214, as would be apparent to those of ordinary skill in the art, with the benefit of this disclosure, the information handling system 214 may include any instrumentality or aggregate of instrumentalities operable to compute, classify, process, transmit, receive, retrieve, origi-

6

nate, switch, store, display, manifest, detect, record, reproduce, handle, or utilize any form of information, intelligence, or data for business, scientific, control, or other purposes. For example, the information handling system 214 may be a network storage device, or any other suitable device and may vary in size, shape, performance, functionality, and price. For instance, in one exemplary embodiment, the information handling system 214 may be used to monitor the amount of materials in the pre-gel storage unit 202 over time and/or alert a user when the contents of the pre-gel storage unit 202 reaches a threshold level. The user may designate a desired sampling interval at which the information handling system 214 may take a reading of the load sensors 212. The information handling system 214 may then compare the load sensor readings to the threshold value to determine if the threshold value is reached. If the threshold value is reached, the information handling system 214 may alert the user. In one embodiment, the information handling system 214 may provide a real-time visual depiction of the amount of materials contained in the pre-gel storage unit 202.

Moreover, as would be appreciated by those of ordinary skill in the art, with the benefit of this disclosure, the load sensors 212 may be coupled to the information handling system 214 through a wired or wireless (not shown) connection. As would be appreciated by those of ordinary skill in the art, with the benefit of this disclosure, in one exemplary embodiment, the dry polymer material may be replaced with a Liquid Gel Concentrate ("LGC") material that consists of the dry polymer mixed in a carrier fluid. In this exemplary embodiment, the feeder and mixer mechanisms would be replaced with a metering pump of suitable construction to inject the LGC into the water stream, thus initiating the hydration process.

FIG. 3 depicts an IPB in accordance with a second exemplary embodiment of the present invention, denoted generally by reference numeral 300. The IPB 300 comprises a pre-gel storage unit 302 resting on legs 308. The pre-gel storage unit 302 in this embodiment may include a central core 304 for storage and handling of materials. In one embodiment, the central core 304 may be used to store a dry gel powder for making gelled fracturing fluids. The pre-gel storage unit 302 may further comprise an annular space 306 for hydration volume. As would be appreciated by those of ordinary skill in the art, with the benefit of this disclosure, the gel powder may comprise a dry polymer. Specifically, the dry polymer may comprise a number of different materials, including, but not limited to, wg18, wg35, wg36 (available from Halliburton Energy Services of Duncan, Okla.) or any other guar or modified guar gelling agents.

The materials from the central core 304 of the pre-gel storage unit 302 may be directed to a mixer 310 as a first input through a feeder 312. As would be appreciated by those of ordinary skill in the art, with the benefit of this disclosure, in one embodiment, the mixer 310 may be a growler mixer and the feeder 312 may be a screw feeder which may be used to provide a volumetric metering of the materials directed to the mixer 310. A water pump 314 may be used to supply water to the mixer 310 as a second input. A variety of different pumps may be used as the water pump 314 depending on the user preferences. For instance, the water pump 314 may be a centrifugal pump, a progressive cavity pump, a gear pump or a peristaltic pump. The mixer 310 mixes the gel powder from the pre-gel storage unit 302 with the water from the water pump 314 at the desired concentration and the finished gel is discharged from the mixer 310. As discussed above with reference to the storage

units **102**, the pre-gel storage unit **302** may rest on load sensors **316** which may be used for monitoring the amount of materials in the pre-gel storage unit **302**. The change in weight, mass or volume can be used to control the metering of material from the pre-gel storage unit **302** at a given set point.

In this embodiment, once the gel having the desired concentration is discharged from the mixer **310**, it is directed to the annular space **306**. The gel mixture is maintained in the annular space **306** for hydration. Once sufficient time has passed and the gel is hydrated, it is discharged from the annular space **306** through the discharge line **318**.

FIG. 4 depicts a cross sectional view of a storage unit in an IPB **400** in accordance with a third exemplary embodiment of the present invention. The IPB **400** comprises a pre-gel storage unit **402** resting on legs **404**. The pre-gel storage unit **402** in this embodiment may include a central core **406** for storage and handling of materials. In one embodiment, the central core **406** may be used to store a dry gel powder for making gelled fracturing fluids. As would be appreciated by those of ordinary skill in the art, with the benefit of this disclosure, the gel powder may comprise a dry polymer. Specifically, the dry polymer may be any agent used to enhance fluid properties, including, but not limited to, wg18, wg35, wg36 (available from Halliburton Energy Services of Duncan, Okla.) or any other guar or modified guar gelling agents. The pre-gel storage unit **402** may further comprise an annular space **408** which may be used as a hydration volume. In this embodiment, the annular space **408** contains a tubular hydration loop **410**.

The materials from the central core **406** of the pre-gel storage unit **402** may be directed to a mixer **412** as a first input through a feeder **414**. As would be appreciated by those of ordinary skill in the art, with the benefit of this disclosure, in one embodiment, the mixer **412** may be a growler mixer and the feeder **414** may be a screw feeder which may be used to provide a volumetric metering of the materials directed to the mixer **412**. A water pump **416** may be used to supply water to the mixer **412** as a second input. A variety of different pumps may be used as the water pump **416** depending on the user preferences. For instance, the water pump **416** may be a centrifugal pump, a progressive cavity pump, a gear pump or a peristaltic pump. The mixer **412** mixes the gel powder from the pre-gel storage unit **402** with the water from the water pump **416** at the desired concentration and the finished gel is discharged from the mixer **412**. As discussed above with reference to FIG. 1, the pre-gel storage unit **402** may rest on load sensors **418** which may be used for monitoring the amount of materials in the pre-gel storage unit **402**. The change in weight, mass or volume can be used to control the metering of material from the pre-gel storage unit **402** at a given set point.

In this embodiment, once the gel having the desired concentration is discharged from the mixer **412**, it is directed to the annular space **408** where it enters the tubular hydration loop **410**. As would be appreciated by those of ordinary skill in the art, with the benefit of this disclosure, the portions of the gel mixture are discharged from the mixer **412** at different points in time, and accordingly, will be hydrated at different times. Specifically, a portion of the gel mixture discharged from the mixer **412** into the annular space **408** at a first point in time,  $t_1$ , will be sufficiently hydrated before a portion of the gel mixture which is discharged into the annular space **408** at a second point in time,  $t_2$ . Accordingly, it is desirable to ensure that the gel mixture is transferred through the annular space **408** in a First-In-First-Out (FIFO) mode. To that end, in the third exemplary embodiment, a

tubular hydration loop **410** is inserted in the annular space **408** to direct the flow of the gel as it is being hydrated.

As would be appreciated by those of ordinary skill in the art, with the benefit of this disclosure, in order to achieve optimal performance, the tubular hydration loop **410** may need to be cleaned during a job or between jobs. In one embodiment, the tubular hydration loop **410** may be cleaned by passing a fluid such as water through it. In another exemplary embodiment, a pigging device may be used to clean the tubular hydration loop **410**.

Returning to FIG. 1, the IMSBS **100** may include one or more blenders **108** located at the bottom of the storage units **102**. In one embodiment, multiple storage units **102** may be positioned above a blender **108** and be operable to deliver solid materials to the blender **108**. FIG. 5 depicts a close up view of the interface between the storage units **102** and the blender **108**. As depicted in FIG. 5, gravity directs the solid materials from the storage units **102** to the blender **108** through the hopper **502**, obviating the need for a conveyor system.

Returning to FIG. 1, the IMSBS **100** may also include one or more liquid additive storage modules **110**. The liquid additive storage modules **110** may contain a fluid used in preparing the desired well treatment fluid. As would be appreciated by those of ordinary skill in the art, with the benefit of this disclosure, depending on the well treatment fluid being prepared, a number of different fluids may be stored in the liquid additive storage modules **110**. Such fluids may include, but are not limited to, surfactants, acids, cross-linkers, breakers, or any other desirable chemical additives. As discussed in detail with respect to storage units **102**, load sensors (not shown) may be used to monitor the amount of fluid in the liquid additive storage modules **110** in real time and meter the amount of fluids delivered to the blender **108**. As would be appreciated by those of ordinary skill in the art, with the benefit of this disclosure, a pump may be used to circulate the contents and maintain constant pressure at the head of the liquid additive storage modules **110**. Because the pressure of the fluid at the outlet of the liquid additive storage modules **110** is kept constant and the blender **108** is located beneath the liquid additive storage modules **110**, gravity assists in directing the fluid from the liquid additive storage modules **110** to the blender **108**, thereby obviating the need for a pump or other conveyor systems to transfer the fluid.

As depicted in more detail in FIG. 5, the blender **108** includes a fluid inlet **112** and an optional water inlet **504**. Once the desired materials are mixed in the blender **108**, the materials exit the blender **108** through the outlet **114**.

In one embodiment, when preparing a well treatment fluid, a base gel is prepared in the IPB **106**. In one embodiment, the gel prepared in the IPB may be directed to an annular space **406** for hydration. In another exemplary embodiment, the annular space may further include a hydration loop **410**. In one exemplary embodiment, the resulting gel from the IPB **106** may be pumped to the centrally located blender **108**. Each of the base gel, the fluid modifying agents and the solid components used in preparing a desired well treatment fluid may be metered out from the IPB **106**, the liquid additive storage module **110** and the storage unit **102**, respectively. The blender **108** mixes the base gel with other fluid modifying agents from the liquid additive storage modules **110** and the solid component(s) from the storage units **102**. As would be appreciated by those of ordinary skill in the art, with the benefit of this disclosure, when preparing a fracturing fluid the solid component may be a dry proppant. In one exemplary embodiment, the dry proppant may

be gravity fed into the blending tub through metering gates. Once the blender **108** mixes the base gel, the fluid modifying agent and the solid component(s), the resulting well treatment fluid may be directed to a down hole pump (not shown) through the outlet **114**. A variety of different pumps may be used to pump the output of the IMSBS down hole. For instance, the pump used may be a centrifugal pump, a progressive cavity pump, a gear pump or a peristaltic pump. In one exemplary embodiment, chemicals from the liquid additive storage modules **110** may be injected in the manifolds leading to and exiting the blender **108** in order to bring them closer to the centrifugal pumps and away from other chemicals when there are compatibility or reaction issues.

As would be appreciated by those of ordinary skill in the art, with the benefit of this disclosure, the mixing and blending process may be accomplished at the required rate dictated by the job parameters. As a result, pumps that transfer the final slurry to the down hole pumps typically have a high horsepower requirement. *FIG. 7 depicts a pumping system in accordance with an exemplary embodiment of the present invention, denoted generally with reference numeral 700.* In one exemplary embodiment, shown in *FIG. 7*, the transfer pump **702** may be powered by a natural gas fired engine or a natural gas fired generator set **714**. In another exemplary embodiment, the transfer pump may be powered by electricity from a power grid. Once the fluid system is mixed and blended with proppant and other fluid modifiers it is boosted to the high horsepower down hole pumps **704**. The down hole pumps pump the slurry through the high pressure ground manifold **706** to the well head **708** and down hole. In one embodiment, the down hole pumps **704** may be powered by a natural gas fired engine, a natural gas fired generator set **714** or electricity from a power grid. The down hole pumps typically account for over two third of the horsepower on location, thereby reducing the carbon footprint of the overall operations.

In one exemplary embodiment, the natural gas used to power the transfer pumps, the down hole pumps or the other system components may be obtained from the field on which the subterranean operations are being performed **720**. In one embodiment, the natural gas may be converted to liquefied natural gas **712** and used to power pumps and other equipment that would typically be powered by diesel fuel. In another embodiment, the natural gas may be used to provide power through generator sets **714**. The natural gas from the field may undergo conditioning **710** before being used to provide power to the pumps and other equipment. The conditioning process may include cleaning the natural gas, compressing the natural gas in compressor stations and if necessary, removing any water contained therein.

As would be appreciated by those of ordinary skill in the art, with the benefit of this disclosure, the IMSBS may include a different number of storage units **102**, IPBs **106** and/or liquid additive storage modules **110**, depending on the system requirements. For instance, in another exemplary embodiment (not shown), the IMSBS may include three storage units, one IPB and one liquid additive storage module.

*FIG. 6* depicts an isometric view of IMSBS in accordance with an exemplary embodiment of the present invention, denoted generally with reference numeral **600**. As depicted in *FIG. 6*, each of the storage units **602**, each of the liquid additive storage modules **604** and each of the IPBs **606** may be arranged as an individual module. In one embodiment, one or more of the storage units **602**, the liquid additive storage modules **604** and the IPBs **606** may include a latch system which is couplable to a truck or trailer which may be

used for transporting the module. In one embodiment, the storage units **602** may be a self-erecting storage unit as disclosed in U.S. patent application Ser. No. 12/235,270, assigned to Halliburton Energy Services, Inc., which is incorporated by reference herein in its entirety. Accordingly, the storage units **602** may be specially adapted to connect to a vehicle which may be used to lower, raise and transport the storage unit **602**. Once at a jobsite, the storage unit **602** may be erected and filled with a predetermined amount of a desired material. A similar design may be used in conjunction with each of the modules of the IMSBS **600** disclosed herein in order to transport the modules to and from a job site. Once the desired number of storage units **602**, the liquid additive storage modules **604** and the IPBs **606** are delivered to a job site, they are erected in their vertical position. Dry materials such as proppants or gel powder may then be filled pneumatically to the desired level and liquid chemicals may be pumped into the various storage tanks. Load sensors (not shown) may be used to monitor the amount of materials added to the storage units **602**, the liquid additive storage modules **604** and the IPBs **606** in real time.

As would be appreciated by those of ordinary skill in the art, with the benefit of this disclosure, an IMSBS **600** in accordance with an exemplary embodiment of the present invention which permits accurate, real-time monitoring of the contents of the storage units **602**, the liquid additive storage modules **604** and/or the IPBs **606** provides several advantages. For instance, an operator may use the amount of materials remaining in the storage units **602**, the liquid additive storage modules **604** and/or the IPBs **606** as a quality control mechanism to ensure that material consumption is in line with the job requirements. Additionally, the accurate, real-time monitoring of material consumption expedites the operator's ability to determine the expenses associated with a job.

As would be appreciated by those of ordinary skill in the art, with the benefit of this disclosure, the different equipment used in an IMSBS in accordance with the present invention may be powered by any suitable power source. For instance, the equipment may be powered by a combustion engine, electric power supply which may be provided by an on-site generator or by a hydraulic power supply.

Therefore, the present invention is well-adapted to carry out the objects and attain the ends and advantages mentioned as well as those which are inherent therein. While the invention has been depicted and described by reference to exemplary embodiments of the invention, such a reference does not imply a limitation on the invention, and no such limitation is to be inferred. The invention is capable of considerable modification, alteration, and equivalents in form and function, as will occur to those ordinarily skilled in the pertinent arts and having the benefit of this disclosure. The depicted and described embodiments of the invention are exemplary only, and are not exhaustive of the scope of the invention. Consequently, the invention is intended to be limited only by the spirit and scope of the appended claims, giving full cognizance to equivalents in all respects. The terms in the claims have their plain, ordinary meaning unless otherwise explicitly and clearly defined by the patentee.

What is claimed is:

- [1.** An integrated material blending and storage system comprising:
  - a storage unit;
  - a blender located under the storage unit;
  - wherein the blender is operable to receive a first input from the storage unit through a hopper;

11

a liquid additive storage module having a first pump to maintain constant pressure at an outlet of the liquid additive storage module;  
 wherein the blender is operable to receive a second input from the liquid additive storage module; and  
 a pre-gel blender, wherein the pre-gel blender comprises at least a pre-gel storage unit resting on a leg, further wherein the pre-gel storage unit comprises a central core and an annular space, wherein the annular space hydrates the contents of the pre-gel blender;  
 wherein the blender is operable to receive a third input from the pre-gel blender;  
 wherein gravity directs the contents of the storage unit, the liquid additive storage module and the pre-gel blender to the blender;  
 a second pump; and  
 a third pump;  
 wherein the second pump directs the contents of the blender to the third pump; and  
 wherein the third pump directs the contents of the blender down hole;  
 wherein at least one of the second pump and the third pump is powered by one of natural gas and electricity.]

[2. The system of claim 1, wherein the storage unit comprises a load sensor.]

[3. The system of claim 1, wherein the pre-gel blender comprises:  
 a feeder coupling the pre-gel storage unit to a first input of a mixer;  
 a fourth pump coupled to a second input of the mixer;  
 wherein the pre-gel storage unit contains a solid component of a well treatment fluid;  
 wherein the feeder supplies the solid component of the well treatment fluid to the mixer;  
 wherein the fourth pump supplies a fluid component of the well treatment fluid to the mixer; and  
 wherein the mixer outputs a well treatment fluid.]

[4. The system of claim 3, wherein the well treatment fluid is a gelled fracturing fluid.]

[5. The system of claim 4, wherein the solid component is a gel powder.]

[6. The system of claim 4, wherein the fluid component is water.]

[7. The system of claim 3, wherein the central core contains the solid component of the well treatment fluid.]

[8. The system of claim 3, wherein the well treatment fluid is directed to the annular space.]

[9. The system of claim 3, wherein the annular space comprises a tubular hydration loop.]

[10. The system of claim 9, wherein the well treatment fluid is directed from the mixer to the tubular hydration loop.]

[11. The system of claim 3, wherein the well treatment fluid is selected from the group consisting of a fracturing fluid and a sand control fluid.]

[12. The system of claim 3, further comprising a power source to power at least one of the feeder, the mixer and the pump.]

[13. The system of claim 12, wherein the power source is selected from the group consisting of a combustion engine, an electric power supply and a hydraulic power supply.]

[14. The system of claim 13, wherein one of the combustion engine, the electric power supply and the hydraulic power supply is powered by natural gas.]

[15. The system of claim 1, further comprising a load sensor coupled to one of the storage unit, the liquid additive storage module or the pre-gel blender.]

12

[16. The system of claim 15, further comprising an information handling system communicatively coupled to the load sensor.]

[17. The system of claim 15, wherein the load sensor is a load cell.]

[18. The system of claim 15, wherein a reading of the load sensor is used for quality control.]

[19. The system of claim 1, wherein the electricity is derived from one of a power grid and a natural gas generator set.]

[20. A modular integrated material blending and storage system comprising:  
 a first module comprising a storage unit;  
 a second module comprising a liquid additive storage unit and a first pump for maintaining pressure at an outlet of the liquid additive storage unit; and  
 a third module comprising a pre-gel blender, wherein the pre-gel blender comprises at least a pre-gel storage unit resting on a leg, further wherein the pre-gel storage unit comprises a central core and an annular space, wherein the annular space hydrates the contents of the pre-gel blender;  
 wherein an output of each of the first module, the second module and the third module is located above a blender; and  
 wherein gravity directs the contents of the first module through a hopper, the second module and the third module to the blender;  
 a second pump;  
 wherein the second pump directs the output of the blender to a desired down hole location; and  
 wherein the second pump is powered by one of natural gas and electricity.]

[21. The system of claim 20, wherein each of the first module, the second module and the third module is a self erecting module.]

[22. The system of claim 20, wherein the third module comprises:  
 a feeder coupling the pre-gel storage unit to a first input of a mixer;  
 a third pump coupled to a second input of the mixer;  
 wherein the pre-gel storage unit contains a solid component of a well treatment fluid;  
 wherein the feeder supplies the solid component of the well treatment fluid to the mixer;  
 wherein the third pump supplies a fluid component of the well treatment fluid to the mixer; and  
 wherein the mixer outputs a well treatment fluid.]

[23. The system of claim 22, wherein the well treatment fluid is directed to the blender.]

[24. The system of claim 20, wherein the blender mixes the output of the first module, the second module and the third module.]

[25. The system of claim 20, further comprising a fourth pump for pumping an output of the blender down hole.]

[26. The system of claim 25, wherein the fourth pump is selected from the group consisting of a centrifugal pump, a progressive cavity pump, a gear pump and a peristaltic pump.]

27. *A method of providing electric power used in a fracturing operation comprising:  
 generating electricity used in the fracturing operation using at least one on-site generator powered by one or more of conditioned field gas, compressed natural gas, or liquefied natural gas; and  
 providing the electricity powering a plurality of pumps pumping a fracturing fluid down hole during the frac-*



## 13

- turing operation, wherein only the electricity powers the plurality of pumps during the fracturing operation.
28. The method of claim 27, wherein the fracturing fluid is prepared using a blender, and wherein sand or proppant is delivered to the blender from a storage unit using at least gravity and without the use of a powered conveyer.
29. The method of claim 28, wherein the blender is powered using the electricity.
30. The method of claim 27, wherein the conditioned field gas is derived from natural gas obtained from a field on which the fracturing operation is performed.
31. The method of claim 27, wherein an amount of a material used in the fracturing operation is monitored using an information handling system.
32. The method of claim 27, wherein at least a portion of the fracturing fluid is pre-hydrated.
33. The method of claim 27, further comprising providing the electricity powering at least one blender during the fracturing operation.
34. A method of providing electric power used in a fracturing operation comprising:  
generating electricity used in the fracturing operation using at least one on-site generator powered by one or more of conditioned field gas, compressed natural gas, or liquefied natural gas; and  
providing the electricity powering a plurality of pumps pumping a fracturing fluid down hole during the fracturing operation, wherein the plurality of pumps is powered without using diesel during the fracturing operation.
35. The method of claim 34, wherein the fracturing fluid is prepared using a blender, and wherein sand or proppant is delivered to the blender from a storage unit using at least gravity and without the use of a powered conveyer.
36. The method of claim 35, wherein the blender is powered using the electricity.
37. The method of claim 34, wherein the conditioned field gas is derived from natural gas obtained from a field on which the fracturing operation is performed.
38. The method of claim 34, wherein an amount of a material used in the fracturing operation is monitored using an information handling system.

## 14

39. The method of claim 34, wherein at least a portion of the fracturing fluid is pre-hydrated.
40. The method of claim 34, further comprising providing the electricity powering at least one blender during the fracturing operation.
41. A method of providing electric power used in a fracturing operation comprising:  
generating electricity used in the fracturing operation using at least one on-site generator powered by one or more of conditioned field gas, compressed natural gas, or liquefied natural gas; and  
providing the electricity powering equipment preparing and pumping a fracturing fluid during the fracturing operation,  
wherein the equipment pumping the fracturing fluid comprises a plurality of pumps pumping the fracturing fluid down hole, and  
wherein only the electricity powers the plurality of pumps.
42. The method of claim 41, wherein the equipment comprises a blender, and wherein sand or proppant is delivered to the blender from a storage unit using at least gravity and without the use of a powered conveyer.
43. The method of claim 41, wherein the conditioned field gas is derived from natural gas obtained from a field on which the fracturing operation is performed.
44. The method of claim 41, wherein an amount of a material used in the fracturing operation is monitored using an information handling system.
45. The method of claim 41, wherein at least a portion of the fracturing fluid is pre-hydrated.
46. The method of claim 41, wherein the equipment preparing the fracturing fluid comprises a blender.
47. The method of claim 27 wherein the liquefied natural gas is derived from natural gas obtained from a field on which the fracturing operation is performed.
48. The method of claim 27 wherein the compressed natural gas is derived from natural gas obtained from a field on which the fracturing operation is performed.

\* \* \* \* \*