

**(12) STANDARD PATENT**  
**(19) AUSTRALIAN PATENT OFFICE**

(11) Application No. **AU 2012206575 B2**

(54) Title  
**Method and device for laying down and tensioning an impermeable cover for hydraulic works in loose material**

(51) International Patent Classification(s)  
**E02B 3/16 (2006.01)**

(21) Application No: **2012206575** (22) Date of Filing: **2012.01.12**

(87) WIPO No: **WO12/095483**

(30) Priority Data

|                      |                   |              |
|----------------------|-------------------|--------------|
| (31) Number          | (32) Date         | (33) Country |
| <b>MI2011A000028</b> | <b>2011.01.14</b> | <b>IT</b>    |

(43) Publication Date: **2012.07.19**

(44) Accepted Journal Date: **2015.07.09**

(71) Applicant(s)  
**GSI Geosyntec Investment B.V.**

(72) Inventor(s)  
**Scuero, Alberto**

(74) Agent / Attorney  
**Spruson & Ferguson, GPO Box 3898, SYDNEY, NSW, 2001**

(56) Related Art  
**US 5082397**



- (51) International Patent Classification:  
E02B 3/16 (2006.01)
- (21) International Application Number:  
PCT/EP2012/050423
- (22) International Filing Date:  
12 January 2012 (12.01.2012)
- (25) Filing Language: English
- (26) Publication Language: English
- (30) Priority Data:  
MI2011A000028 14 January 2011 (14.01.2011) IT
- (71) Applicant (for all designated States except US): GSI  
GEOSYNTEC INVESTMENT B.V. [NL/NL]; c/o Sorato  
Trust B.V., Spoorhaven 88, NL-2651 AV Berkel en  
Rodenrijs (NL).
- (72) Inventor; and  
(75) Inventor/Applicant (for US only): SCUERO, Alberto  
[IT/CH]; CH-6874 Castel San Pietro (CH).
- (74) Agent: COLOBERTI & LUPPI SRL; Via E. De Amicis  
25, I-20123 Milan (IT).

- (81) Designated States (unless otherwise indicated, for every  
kind of national protection available): AE, AG, AL, AM,  
AO, AT, AU, AZ, BA, BB, BG, BH, BR, BW, BY, BZ,  
CA, CH, CL, CN, CO, CR, CU, CZ, DE, DK, DM, DO,  
DZ, EC, EE, EG, ES, FI, GB, GD, GE, GH, GM, GT, HN,  
HR, HU, ID, IL, IN, IS, JP, KE, KG, KM, KN, KP, KR,  
KZ, LA, LC, LK, LR, LS, LT, LU, LY, MA, MD, ME,  
MG, MK, MN, MW, MX, MY, MZ, NA, NG, NI, NO, NZ,  
OM, PE, PG, PH, PL, PT, QA, RO, RS, RU, RW, SC, SD,  
SE, SG, SK, SL, SM, ST, SV, SY, TH, TJ, TM, TN, TR,  
TT, TZ, UA, UG, US, UZ, VC, VN, ZA, ZM, ZW.
- (84) Designated States (unless otherwise indicated, for every  
kind of regional protection available): ARIPO (BW, GH,  
GM, KE, LR, LS, MW, MZ, NA, RW, SD, SL, SZ, TZ,  
UG, ZM, ZW), Eurasian (AM, AZ, BY, KG, KZ, MD, RU,  
TJ, TM), European (AL, AT, BE, BG, CH, CY, CZ, DE,  
DK, EE, ES, FI, FR, GB, GR, HR, HU, IE, IS, IT, LT, LU,  
LV, MC, MK, MT, NL, NO, PL, PT, RO, RS, SE, SI, SK,  
SM, TR), OAPI (BF, BJ, CF, CG, CI, CM, GA, GN, GQ,  
GW, ML, MR, NE, SN, TD, TG).

Published:

— with international search report (Art. 21(3))

(54) Title: METHOD AND DEVICE FOR LAYING DOWN AND TENSIONING AN IMPERMEABLE COVER FOR HYDRAULIC WORKS IN LOOSE MATERIAL

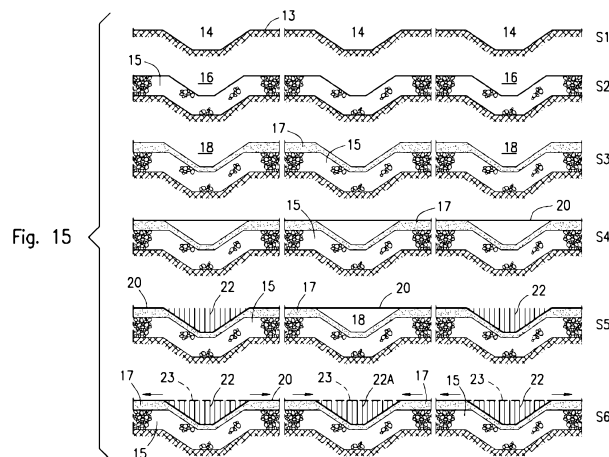

(57) Abstract: A method and a device suitable for laying down and tensioning an impermeable cover comprising a plurality of geostrips (20) for protection of hydraulic structures (10) consisting of loose material, such as a dam, canal, and/or water basin. A plurality of trenches or grooves (14) are excavated into the soil (12, 13) of the hydraulic structure (10), all running in a predetermined direction; each trench (14) is shaped to have a finished inner surface suitable to come in contact with the geostrips (20) provided by a compactable, inert loose material having a fine particle size, for example less than 0.6-0.5 mm. In the case of soils containing inert rocky materials or materials with high granulometry, each trench (14) can optionally include a layer of drainage material (15). The laying down of the impermeable cover consisting of said plurality of geostrips (20), is then carried out resting the geostrips (20) in contact with the soil surface, bridging the trenches (14); the geostrips (20), are sealed along overlapped edges, pushed into a first set of alternate trenches (14A), and locked by a first ballast material (22), leaving the geostrips (20) bridging a second set of alternate trenches (14B) adjacent to the previous ones. The geostrips (20) are then tensioned by pushing and locking them into the second set of trenches (14B) by a second ballast material (22).

## METHOD AND DEVICE FOR LAYING DOWN AND TENSIONING AN IMPERMEABLE COVER FOR HYDRAULIC WORKS IN LOOSE MATERIAL

### BACKGROUND OF THE INVENTION

5

This invention refers to a method and a device, or system, for laying down and tensioning an impermeable cover comprising sheet material consisting of a plurality of side by side arranged strips of a geomembrane, referred to also as "geostrips", for the protection of hydraulic structures consisting of loose natural material such as, for example, clay, earth, gravel, rocky material and/or their combination, in particular dams, canals, and/or natural and/or artificial water basins, or similar hydraulic structures, by which a blocking and a contemporary controlled stretching of the impermeable cover is achieved during its installation and laying down operations.

15

For the purposes of this description, "geomembrane" means an impermeable cover consisting of a plurality of geostrips and/or sheet material sealingly connected to each other along their longitudinal edges, in which each geostrip or sheet includes at least one or more layers of any geosynthetic material as defined below, suitable to be used in contact with the ground; for example, the geostrips sheets could consist of a single layer of a natural or synthetic polymeric resin, or a bituminous material as defined below, or by multiple layers of any geotechnical material, such as a geocomposite consisting for example of an assembled structure comprising an impermeable layer as defined above, coupled with a layer of a geotextile suitable for the intended use.

20

25

### STATE OF THE ART

30

As it is known, the bottom and/or side surfaces of hydraulic structures, in particular hydraulic works consisting of loose material, such as dams, canals and/or water basins to come in contact with water, must be suitably

protected and waterproofed by an impermeable cover consisting of a plurality of side by side arranged sheets, having overlapped and sealed edges, both to prevent water loss through the loose material of the body of the hydraulic structure, preventing any water seepage, and the possibility of subsidence and/or erosion of the same body in loose material of the hydraulic structure, and/or of the surface in contact with water.

Over the time various methods and systems have been developed for covering and protecting by a geomembrane, hydraulic works or structure in concrete material, in particular hydraulic works consisting of loose material, according to which special metal profiles were used to lock and tensioning a number of the geostrips, which had to be previously anchored to the surfaces of the hydraulic works.

For fastening a covering to hydraulic works consisting of loose material, the use of short length of fastening strips in PVC or other polymeric material suitable for a geotechnical use, namely suitable to come in contact with a soil has also been suggested, by partially embedding said strips into the same soil, then thermally welding an impermeable cover of geostrips to the protruding portion of said fastening strips.

The use of a geomembrane has proved to be extremely beneficial, especially for covering systems in which use is made of geomembranes exposed to water and air, both due to the quality and efficiency of the waterproofing, as well as for its comparatively low cost and durability over the time.

A suitable system of canalization obtained by the same anchoring profiles for the geomembrane, also allowed for a drainage and evacuation of water that had seeped into the loose material of the body of the hydraulic structure or work, and any water leakages caused by breakages and/or perforation of the protective geomembrane; this prevented the membrane from being subject to

bulging and/or high stresses that might have compromised its structural integrity.

Anchoring systems for geomembrane covers are described for example in EP-A-0 459 015, EP-A-0 722 016 and EP-A-1 137 850.

In the case of geomembranes exposed to the environment, in addition to any stresses caused by water seeping into the soil, it's also necessary to take into account the possibility of wave motions in the water, or the strong action of the wind, caused by cyclones for example, which tend to suck up the geomembrane when it is not covered by the water, pulling it away from its anchorage points.

Lastly US-A-5082397 discloses a method and a device for laying down an impermeable cover comprising a plurality of side by side arranged plastic sheets for protecting hydraulic works, in which the operations of excavating a trench by removing the soil, unrolling and laying down of an unfolded plastic sheet, and immediately ballasting the plastic sheet laid down into the trench by merely covering the same plastic sheet with the previously removed soil, are conjointly made during the excavation, and repeatedly performed during successive passes up to complete an entire region to be protected. Therefore in laying down the plastic sheet, no tensioning is provided, and the formation of folds and/or bags is made possible leading to failure of the sheet material and water infiltration.

Covering systems of this kind have therefore proved to be extremely complex and expensive, and not always suitable for a proper application to hydraulic works.

Therefore a need exists to find an alternative solution that is easy to install,

comparatively less expensive, and which at the same time allows a firm anchorage and a controlled tensioning of the geostrips during laying-down and installation, while also providing suitable water drainage.

A correct tensioning of the geostrips during the construction and laying down of the impermeable cover, is important because it prevents the formation of folds and/or pockets, which, if accidentally perforated, would constitute large, preferential passageways through which water would seep, thus generating all the problems that should be avoided by the use of the impermeable cover; the use of a correctly tensioned geostrips during the construction of the cover can therefore prevent the loss of water through the body of a hydraulic work in loose material, as well as any water seepage and possible subsidence and/or erosion of the same body, and/or of the surface of the hydraulic work in contact with water.

Therefore, there is a further need to provide a method and a device suitable for providing an impermeable cover for hydraulic works, in which the impermeable cover comprises a plurality of side by side arranged geostrips in an elastically yieldable synthetic material, and in which the excavation of the trenches, the laying down of the geostrips and the ballasting may be performed by separate steps, allowing an appropriate tensioning of the geostrips to avoid formations of folds and/or bags and water infiltration into the soil.

#### OBJECT OF THE INVENTION

It is an object of the present invention to at least substantially satisfy the above needs or to at least provide a useful alternative.

#### SHORT DESCRIPTION OF THE INVENTION

According to a first aspect of the invention, a method has been provided for

laying down and tensioning an impermeable cover comprising a number of geostrips of an elastically yielding synthetic material, on a surface of a hydraulic work in loose material, comprising the steps of:

excavating a plurality of spaced-apart trenches, comprising first and second sets of alternate trenches, which extend in one direction on the surface and into the soil of the hydraulic work;

shaping the individual trenches with a regularly finished surface suitable to come in contact with the geostrips;

laying down and sealingly connecting overlapped edges of a plurality of geostrips, in an unfolded and in a contact condition with the surface of the hydraulic work, maintaining a bridging disposition of the geostrips on the trenches;

pushing the geostrips to penetrate into the cavities of the first set of trenches, locking them by a first ballasting material; and

subsequently tensioning the geostrips pushing them into the cavities of the second set of trenches locking them in a taut condition by a second ballast material.

According to an embodiment, a system has been provided suitable for laying down and tensioning an impermeable cover for the soil surface of a hydraulic work in loose material, according to the above method, in which the impermeable cover comprises a plurality of side by side arranged geostrips of anelastically yieldable synthetic material, having overlapped side edges, and in which the geostrips are held by a ballasting material in a plurality of parallel trenches extending on the hydraulic work surface, the system comprising:

a plurality of anchoring trenches each provided with a cavity shaped with a finished regular contact surface with the geostrips;

said plurality of trenches comprising a first set of alternate trenches, and a second set of alternate trenches, in which each trench of the first set is extending between trenches of the second set of trenches;

a plurality of geostrips transversely and/or longitudinally unfolded to

bridge said first and second set of trenches; and

in which said geostrips are held in a tensioned condition by a first and a second ballast material, into said first and second set of trenches.

5 If the surface of the hydraulic work comprises a clay soil or an inert material with fine particle size, for example less than 0.4 to 0.6 mm, the individual trenches can be directly shaped with a regularly, finished surface to come in contact with the geostrips, consisting of the same inert material of the soil; otherwise if the soil surface where the trenches are excavated or dug  
10 includes rocky material, gravel and/or aggregates of larger dimensions, it is possible to provide the trenches with a first bottom layer consisting of inert material of suitable granulometry and consistency, for example gravel and overlaying the bottom layer with a second layer of fine-grained filtering material such as sand, clay and/or slime that is then shaped to provide  
15 trenches having a longitudinal cavity with a regularly, finished surface suitable to come in contact with the geostrips.

The filling of the trenches with fine-grained material and the shaping of the contact surface, are required in soils having a granulometry higher than the  
20 sand which, during digging or excavation would not allow smooth and regular shaping of the trenches. Any improper shaping of the trenches will result in an improper positioning and tensioning of the geostrips which would lie on the edges of the trenches along irregular lines, thus giving rise to a cover being lain with wavy edges, which would make it difficult, if not  
25 impossible, to weld the overlapped edges of the geostrips, causing folds and/or bags that would reduce the tensioning effect. The filling of the trenches with a loose ballasting material also allows a secondary drainage and filtration function. The presence of layers of drainage and filtering material can be limited to the trenches alone, or extend over the entire  
30 surface of the hydraulic work to be covered by the geostrips.

The presence of a filtering and drainage layer thus allows any water leakage

through the covering geostrips to be collected, and to relieve any negative pressures acting on the cover, arising from the presence of water, such as ground water, on the back side.

The geostrips can be transversely laid over the trenches and then sealingly connected to each other along their overlapped edges, or they can be pre-welded and longitudinally laid down on the trenches, provided that the total width of the geostrips or sheets of pre-welded geostrips is higher than the width between the extreme edges of three or more adjacent trenches.

### SHORT DESCRIPTION OF THE DRAWINGS

Preferred embodiments of the invention will be described hereinafter, by way of examples only, with reference to the accompanying drawings.

Fig. 1 is a perspective view of a water basin comprising an impermeable cover consisting of a geostrips laid down and tensioned according to the invention;

Fig. 2 is an enlarged view of a part of the bottom surface of the water basin of Figure 1, to show the excavation of the anchoring trenches;

Fig. 3 is a sectional view according to line 3-3 of Figure 2;

Fig. 4 is an enlarged sectional view of a trench, according to line 4-4 of Figure 2;

Fig. 5 is a sectional view similar to the one in Figure 4, to show the formation of a drainage layer;

Fig. 6 is a sectional view similar to the one in the previous figures, to show the formation of a filtering or transition layer, subsequently to a drainage layer;

Fig. 7 is a view similar to the one in Figure 2, to show the laying down of a number of geostrips, transversely extending across the trenches;

Fig. 8 is a sectional view according to line 8-8 of Figure 7;

Fig. 9 is a view similar to the one in Figure 7, to show a first penetration of the geostrips into a first set of alternate trenches;

Fig. 10 is a sectional view according to line 10-10 of Figure 9;

5 Fig. 11 is an enlarged sectional view of a trench according to line 11-11 of Figure 9;

Fig. 12 is an enlarged sectional view of a trench, according to line 12-12 of Figure 9;

10 Fig. 13 is a view similar to the one in Figure 9, to show a subsequent penetration and final tensioning of the geostrips into a second set of alternate trenches arranged between the first set of trenches;

Fig. 14 is a sectional view according to line 14-14 of Figure 13;

Fig. 15 is a schematic view, summarizing the main steps of the method according to the invention.

15

#### DETAILED DESCRIPTION OF THE INVENTION

Figure 1 shows, for example, a generic hydraulic work consisting of loose material, comprising a water basin 10 including an embankment 11 having a sloped inner surface 12, and a bottom surface 13 for holding a certain quantity of water.

20

To prevent water loss by seepage into the soil, both the inner surface 12 and the bottom surface 13 of the water basin are usually protected by an impermeable cover consisting of a geomembrane comprising a plurality of geostrips of a synthetic elastically yielding elastomeric material, which must be properly sealed together along their overlapped edges, tensioned and anchored to the ground.

25

30 Any material can be used for the geostrips of the impermeable cover, provided that it is suitable for its intended purpose; in particular it can be chosen from among the synthetic materials listed in the following table, taken

individually or in combination.

| <b>TYPE</b>           | <b>BASIC MATERIAL</b>  | <b>ABBREVIATION</b>  |
|-----------------------|--|--|
| THERMOPLASTIC         | <ul style="list-style-type: none"> <li>- High-density polyethylene</li> <li>- Low and/or high-density polyethylene</li> <li>- Polyethylene</li> <li>- Chlorinated polyethylene</li> <li>- Ethylene-vinyl acetate copolymer</li> <li>- Polypropylene</li> <li>- Polyvinyl chloride</li> </ul> | HDPE<br><br>LLDPE<br><br>PE<br><br>CPE<br><br>EVA/C<br><br>PP<br><br>PVC |
| THERMOPLASTIC RUBBERS | <ul style="list-style-type: none"> <li>- Chlorine-sulfonate polyethylene</li> <li>- Ethylene-propylene copolymer</li> </ul>  | CSPE<br><br>E/P  |
| THERMOSTABLE          | <ul style="list-style-type: none"> <li>- Polyisobutylene</li> <li>- Chloroprene rubber</li> <li>- Ethylene propylene diene monomer</li> <li>- Butyl rubber</li> <li>- Nitrile rubber</li> </ul>  | PIB<br><br>CR<br><br>EPDM<br><br>IIR<br><br>NBR                          |
| BITUMINOUS            | <ul style="list-style-type: none"> <li>- Oxidised bitumen</li> <li>- Polymeric bitumen</li> </ul>  | Prefabricated GM<br><br>-----  |

5 The above list is not exhaustive and also comprises materials that are technically and commercially ascribable to the elastomer and bituminous family.

The geostrips can vary in thickness between 0.2 and 40 mm, with an elastic modulus between 10 and 5,000 MPa, possibly coupled with a geotextile.

According to this invention, to install and anchoring the geostrips to the surfaces 12 and 13 of the water basin 10, as shown in Figures 1 to 4, a plurality of trenches 14 are initially excavated into the soil, parallel to one another and all oriented in a given direction; the trenches 14 must be large enough to accommodate, if necessary, a preset quantity of drainage material and/or filtering material, as explained below. The trenches 14 can be of any suitable shape, for example they can have a rectangular, trapezoidal or semicircular cross section. As shown in the detail in Figure 4, the trenches 14 can be of any width L at the upper edges, and a depth S depending on the nature of the soil and the amount of drainage and/or filtering material in the trenches, while the pitch P between adjacent trenches 14 must be much larger than the width L, for example, between four and ten times L, or higher, so that between adjacent trenches 14 there will be a length of geostrips sufficient to allow for an required elongation by the elastic yielding, needed for tensioning by a suitable ballasting material.

By way of example only, it should be noted that during some experimental tests, trenches having a maximum width L between 600 and 1000 mm, and a depth D between 400 and 700 mm were excavated, maintaining a pitch P between 4 and 10 m.

As previously reported, in cases the soil is composed of inert material of fine size particles, equal to or less than 0.5 to 0.6 mm, such as sand or clay, once the trenches 14 have been excavated, the soil must be adequately compacted, shaping the individual trenches with a longitudinal cavity having a regular, finished contact surface, suitable to come in contact with the geostrips 14.

Optionally, if the characteristics of the soil in which the trenches 14 are excavated are such to include larger aggregates, once the trenches 14 have been excavated, after having properly compacted the soil, the individual trenches are partially filled 14 with a first layer 15 of drainage material,

consisting for example of large-sized gravel; in this way a sort of drainage canal is provided, suitably slanted toward a peripheral manifold.

5 The layer 15 of drainage material can be distributed in the trenches 14 on the bottom surface 13 of the hydraulic work, or water basin 10 alone, while in the case of a sloped surface 12, facing towards the water in the basin 10, it is suggested that the drainage layer 15 be laid over the entire surface, as schematically shown in Figure 5.

10 In all cases, the layer 15 of drainage material in the trenches 14, will be distributed so as to form a longitudinal cavity 16 large enough to hold a second layer 17 of filtering material, as shown in Figure 6, in particular loose, shapeable material, such as earth, fine sand or small-sized gravel, rounded and sharp edges, which thus becomes a transition layer between  
15 the underlying drainage layer 15 and the protective geostrips subsequently laid down.

Once the filtering layer 17 has been distributed in the trenches 14, using an appropriate tooling, such as the bucket of an excavator, a longitudinal canal  
20 18 is provided as shown in Figure 6.

The thicknesses of the drainage layer 15, the filtering layer 17, and consequently the shape and size of the longitudinal canal 18, must be calculated so that the canals 18 can accommodate geostrips large enough to  
25 cause a desired tensioning, as well as to ensure the necessary blocking to withstand external forces such as wind, wave motion and ice.

After the preparation of the trenches 14, or part of them, and their filling with the drainage layer 15 and the filtering layer 17 when necessary to create a  
30 finished contact surface to come in contact with the geostrips, and after having possibly overlapped it with a layer of a protective geotextile, not shown, according to the example in consideration the cover is built by laying

down a number of geostrips 20 transversely or orthogonally across the trenches 14, as shown in Figure 7, unwinding them from rolls; as an alternative to laying down the geostrips transversely 20, as shown in Figure 7 multiple pre-welded geostrips 20 can be laid down, parallel to the trenches 14, provided that the total width of the pre-welded geostrips is greater than the space between the extreme edges of at least three adjacent trenches 14.

The geostrips 20 are initially laid down and unfolded in a flat condition adhering to the soil or a surface of the hydraulic work to be protected, a bridging across the individual trenches 14, as shown in Figure 8; providing for a suitable overlap 21 between the opposite edges of adjacent geostrips, it's possible to achieve a sealing connection between them, for example by thermal welding, vulcanization or a suitable adhesive.

After having laid down and sealingly connected a number of geostrips 20, their anchoring and tensioning should proceed; this is done gradually in successive steps, as shown in Figures 9 to 14 of the attached drawings.

In particular, as shown in Figures 9 and 10 and in detail in Figure 11, the geostrips 20 are first sequentially pushed into the cavities 18 of a first set of alternate trenches 14A, for example the odd-numbered trenches as indicated by the reference numbers 1 and 3 in Figure 9, by a first appropriate ballasting material 22.

More precisely, in ballasting the geostrips 20 into the first set of alternate trenches 14A, the geostrips 20 remain adherent to the soil with an arrangement bridging the remaining second set of even-numbered trenches 14B, adjacent to and interposed between the previous set of trenches 14A, as indicated in Figures 9, 10 and in detail in Figure 12. Having completed the first ballasting step of the geostrips 20 into the cavities of the odd-numbered trenches 14A, the geostrips are then tensioned and ballasted into the cavities of the even-numbered trenches 14B, as shown and indicated by

22A in Figures 13 and 14.

By ballasting in the sequence as previously indicated, a final tensioning is performed of the geostrips 20 that makes them perfectly adhere to the surfaces 12 and 13 of the hydraulic work to be protected. Obviously, care must be taken to ballast the geostrips 20 with appropriate weights to create the desired elongation and the desired tensioning by an elastic yielding ranging, for example, between 2% and 4% in the area of the geostrips 20 between adjacent trenches 14A and 14B, as shown by the arrows W1 and W2 in Figures 13 and 14.

Any type of ballasting material 22 and 22A can be used; for example, it can be selected from among the following: gravel, sand, earth, concrete, or a combination thereof.

Optionally, as shown by 23 in Figure 14, at each trench 14 the ballasting material 22, 22A can be covered with an auxiliary geostrip 23, longitudinally extending over the individual trenches, heat-sealed along the edges to the geostrips 20.

The geostrips 20 and 23 can be of any type, for example, they may be in the form of simple strips of geosynthetic material, or a geocomposite consisting of a combination of geosynthetic and geotextile materials.

In some cases, in the area between adjacent trenches, the transition layer may include a geotextile, a geocomposite, a geonet or other anti-perforation material suitable for the protection of the geostrips; likewise the drainage layer may consist of any geodrainage material such as gravel, geonet, geogrid, geomat or combination thereof.

Figure 15 gives an explanatory summary of the main steps from S1 to S5 of the method for laying down and tensioning the geostrips according to this

invention, in particular:

S1 shows the trench excavation step 14;

S2 shows the step of filling the trenches with an optional drainage layer 15;

5 S3 shows the step of filling the trenches 14 with an optional filtering layer 17, shaped with a longitudinal cavity 18 suitable to provide a regular, finished surface to come in contact with the geostrips.

S4 shows the laying down of the geostrips 20 bridging across the trenches 14;

10 S5 shows the pushing and blocking step of the geostrips by a first ballasting material, in the cavities of a first set of trenches such as the odd-numbered trenches 14A;

finally, S6 shows the final step tensioning and anchoring the geostrips, pushing and blocking them into the cavities of the remaining second set of  
15 trenches such as even-numbered trenches 14B by a second ballasting material.

It is to be understood, however, that what has been said and shown in the attached drawings, has been given purely by way of an example of the  
20 general features of the method and system according to this invention; therefore, other modifications or variations may be applied to the shape, size, arrangement and distance between the trenches 14, to the type of material for the drainage and/or filtration layers and the ballasting material, achieving the same effects and the same results without departing from the  
25 claims.

**CLAIMS**

1. A method for laying down and tensioning an impermeable cover comprising a number of geostrips of an elastically yielding synthetic material, on a surface of a hydraulic work in loose material, comprising the steps of:

excavating a plurality of spaced apart trenches, comprising first and second sets of alternate trenches which extend in one direction on the surface and into the soil of the hydraulic work;

shaping the individual trenches with a regularly finished surface suitable to come in contact with the geostrips;

laying down and sealingly connecting overlapped edges of a plurality of geostrips, in an unfolded and in a contact condition with the surface of the hydraulic work, maintaining a bridging disposition of the geostrips on the trenches;

pushing the geostrips to penetrate into the cavities of the first set of trenches, locking them by a first ballasting material; and

subsequently tensioning the geostrips, pushing them into the cavities of the second set of trenches, locking them in a taut condition by a second ballasting material.

2. The method according to claim 1, in which the shaped surface of the trenches in contact with the geostrips, consists of a fine, inert material, with dimensions equal to or less than 0.5 mm.

3. The method according to claim 1, comprising the additional steps of:

partially filling each trench with a first layer of drainage material, and subsequently filling the trench with a second layer of a compactable, filtering inert material; and

configuring the second filtering layer with a longitudinal channel, shaping it with a regular finished contact surface with the geostrips.

4. The method according to claim 1, in which the geostrips are laid down in a transvers direction to the trenches.

5. The method according to claim 1, in which a plurality of pre-welded geostrips is laid down longitudinally to the trenches.

6. The method according to claim 3, in which the layer of drainage material comprises a geodrain.
7. The method according to claim 6, in which the layer of drainage material is chosen from: gravel, geomesh, geogrid, geomat or their combination.
8. The method according to any one of claims 3, 6 or 7, in which the layer of filtering material is chosen from: lime, sand, fine rounded gravel, geomesh, geotextile or their combination.
9. A system suitable for laying down and tensioning an impermeable cover for the soil surface of a hydraulic work in loose material, according to the method of claim 1, in which the impermeable cover comprises a plurality of side by side arranged geostrips of an elastically yieldable synthetic material, having overlapped side edges, and in which the geostrips are held by a ballasting material in a plurality of parallel trenches extending on the hydraulic work surface, the system comprising:
  - a plurality of anchoring trenches each provided with a cavity shaped with a finished regular contact surface with the geostrips, said plurality of trenches comprising a first set of alternate trenches, and a second set of alternate trenches, in which each trench of the first set is extending between trenches of the second set of trenches; and
  - a plurality of geostrips transversely and/or longitudinally unfolded to bridge said first and second set of trenches;
  - wherein said geostrips are held in a tensioned condition by a first and a second ballast material, into said first and second set of trenches.
10. The system according to claim 9, in which a drainage material comprises: gravel, geomesh, geogrid, geomat, singly or in combination.
11. The system according to claim 9, in which a layer of filtering material comprises: sand, earth, clay, lime, used singly or in combination.
12. The system according to claim 11, in which the layer of filtering material further comprises a geotextile, a geomesh, a geocomposite or their combination.

13. The system according to claim 9, in which the first and second ballast material includes: sand, gravel, earth, concrete or their combination.

14. The system according to claim 9, in which the synthetic material of the geostrips is chosen from the materials listed in the following table:

| <b>TYPE</b>           | <b>BASIC MATERIAL</b>  | <b>ABBREVIATION</b>  |
|-----------------------|--|--|
| THERMOPLASTIC         | <ul style="list-style-type: none"> <li>- High-density polyethylene</li> <li>- Low and/or high-density polyethylene</li> <li>- Polyethylene</li> <li>- Chlorinated polyethylene</li> <li>- Ethylene-vinyl acetate copolymer</li> <li>- Polypropylene</li> <li>- Polyvinyl chloride</li> </ul> | HDPE<br><br>LLDPE<br><br>PE<br><br>CPE<br><br>EVA/C<br><br>PP<br><br>PVC |
| THERMOPLASTIC RUBBERS | <ul style="list-style-type: none"> <li>- Chlorine-sulfonate Polyethylene</li> <li>- Ethylene-propylene copolymer</li> </ul>  | CSPE<br><br>E/P  |
| THERMOSTABLE          | <ul style="list-style-type: none"> <li>- Polyisobutylene</li> <li>- Chloroprene rubber</li> <li>- Ethylene propylene diene monomer</li> <li>- Butyl rubber</li> <li>- Nitrile rubber</li> </ul>  | PIB<br><br>CR<br><br>EPDM<br><br>IIR<br><br>NBR                          |
| BITUMINOUS            | <ul style="list-style-type: none"> <li>- Oxidised bitumen</li> <li>- Polymeric bitumen</li> </ul>  | Prefabricated GM   |

15. The system according to claim 13, in which the geostrips have a thickness between 0.2 and 40 mm, and elasticity module between 10 and 5000 MPa.

16. The system according to claim 9, in which the pitch step between the trenches is between four and ten times the maximum width of the trenches.

17. The system according to claim 9, comprising an additional geostrip to cover the first and second ballast material, sealed to the geostrips.

**GSI Geosyntec Investment B.V.**  
Patent Attorneys for the Applicant  
SPRUSON & FERGUSON

2012206575 17 Jun 2015

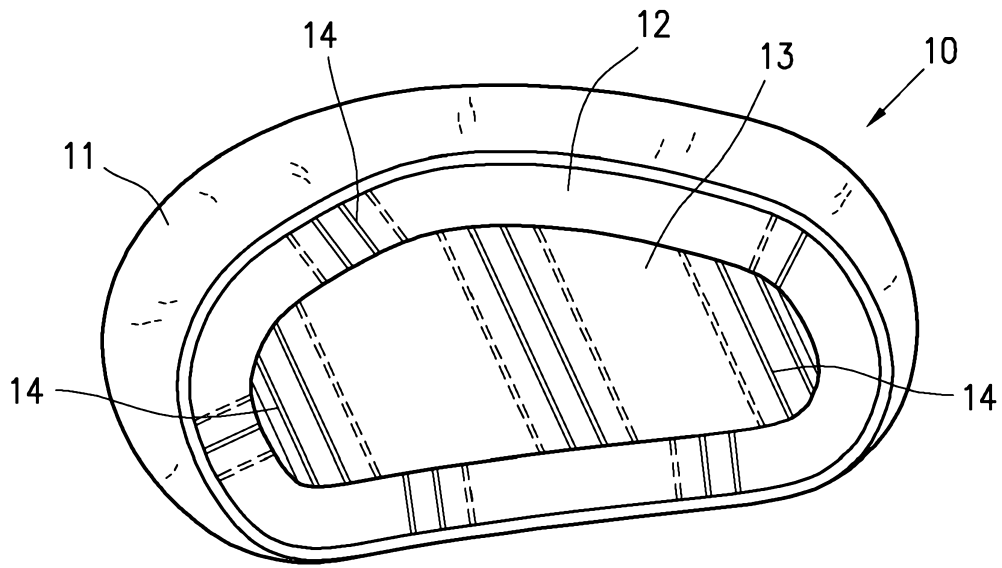

Fig. 1

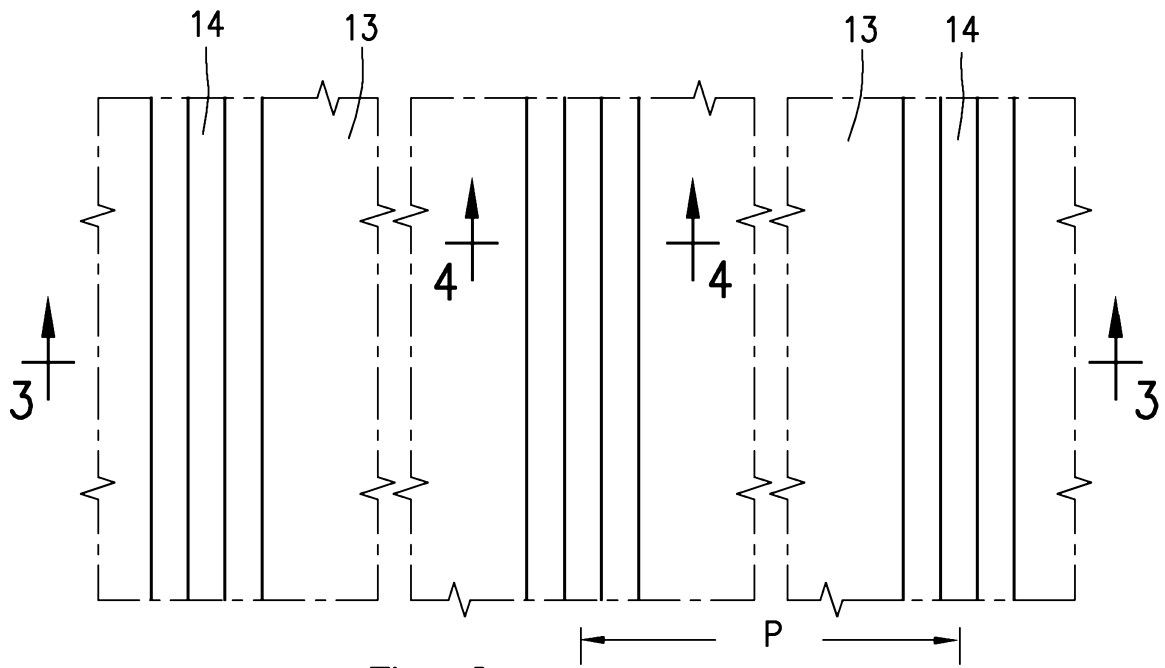

Fig. 2

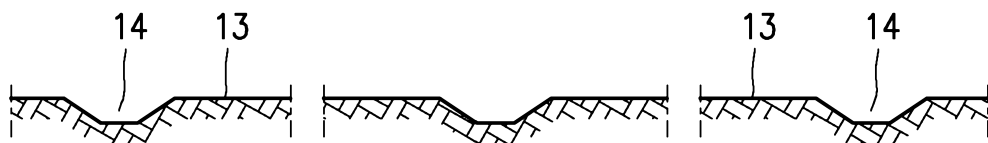

Fig. 3

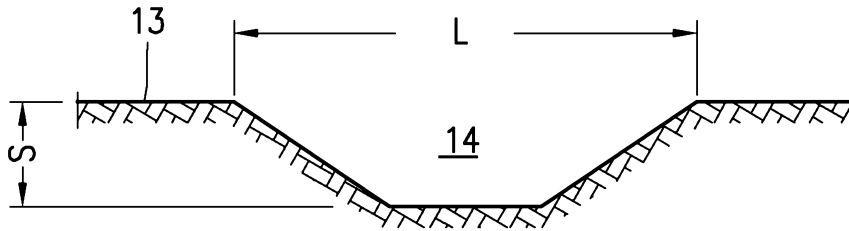

Fig. 4

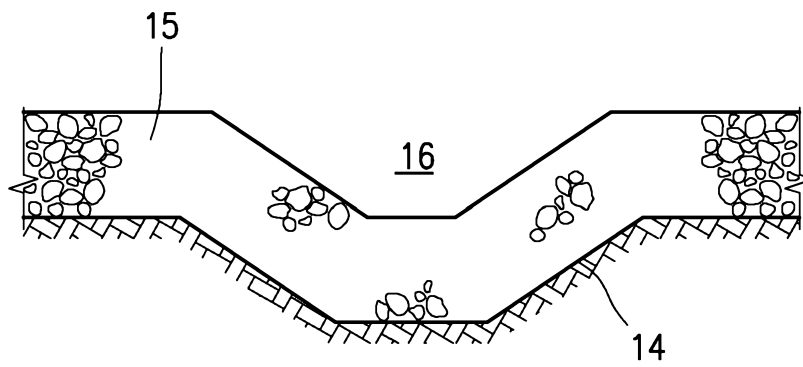

Fig. 5

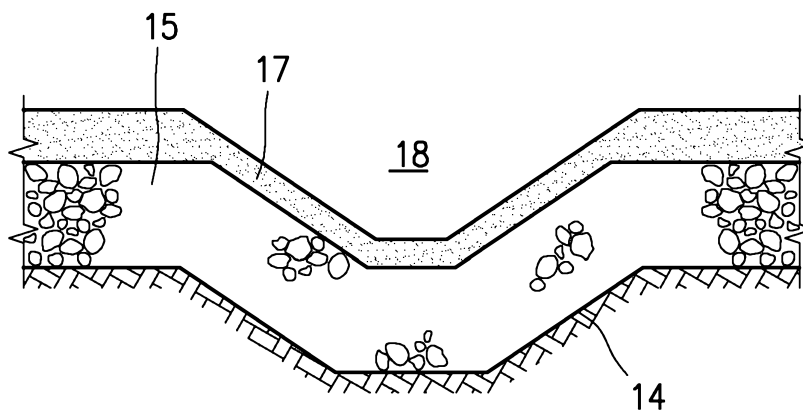

Fig. 6

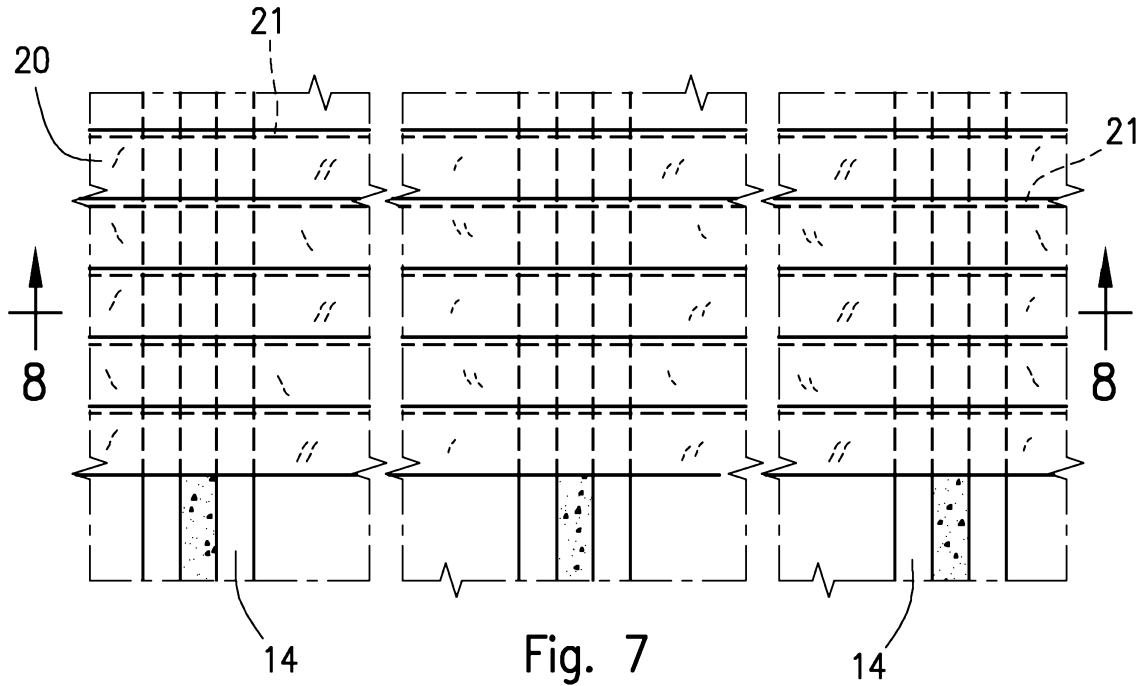

Fig. 7

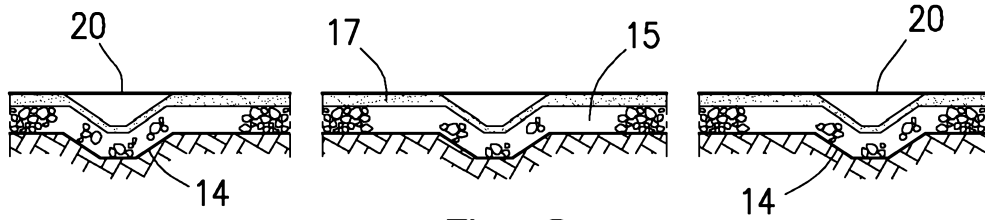

Fig. 8

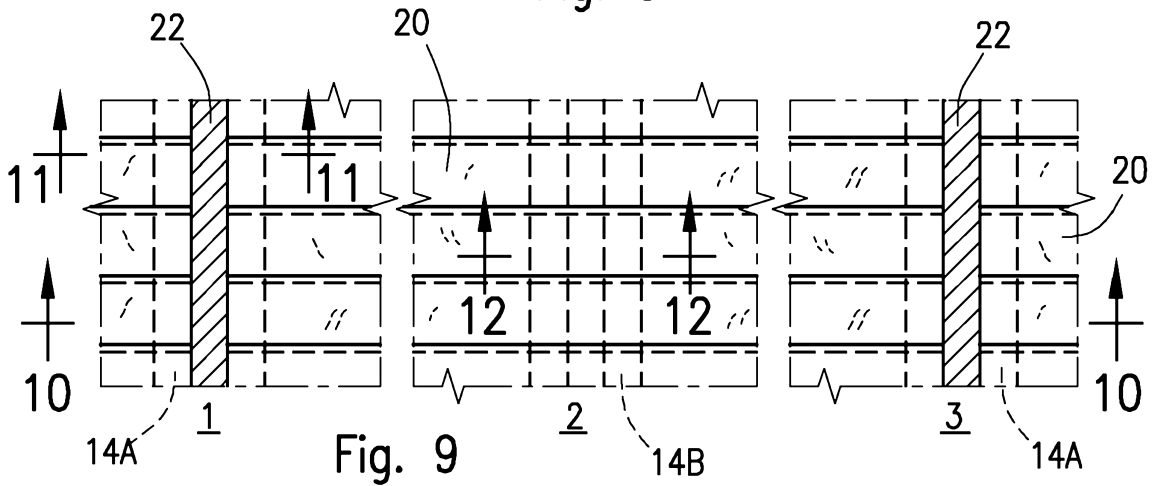

Fig. 9

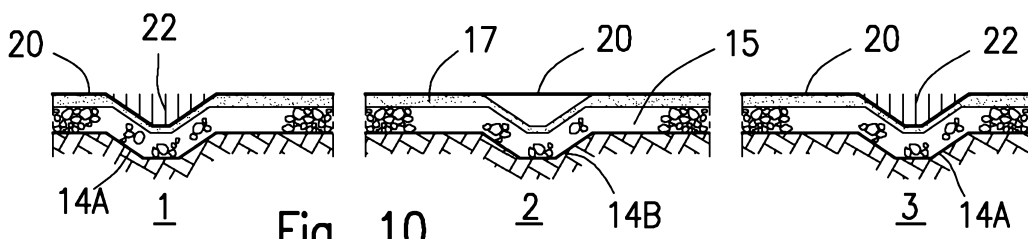

Fig. 10

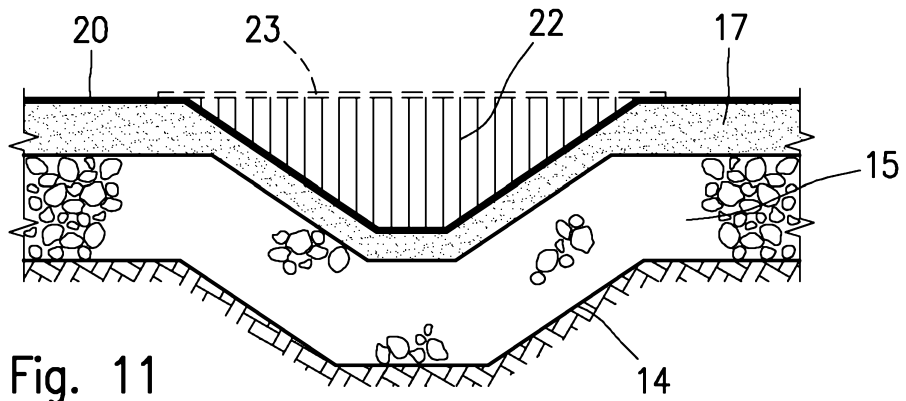

Fig. 11

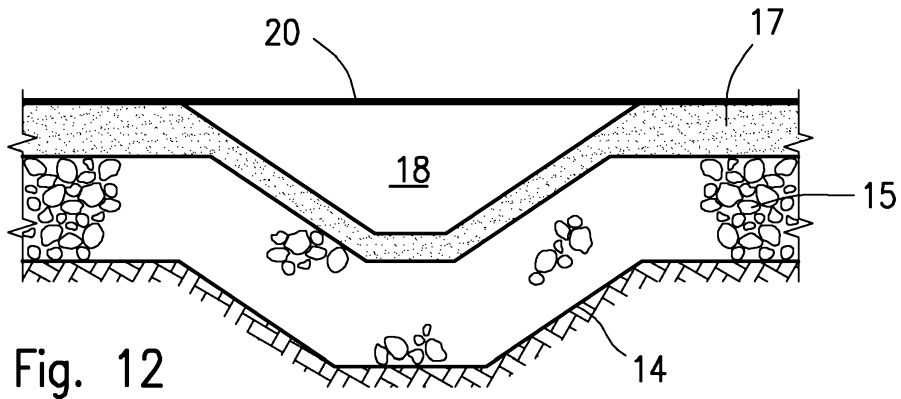

Fig. 12

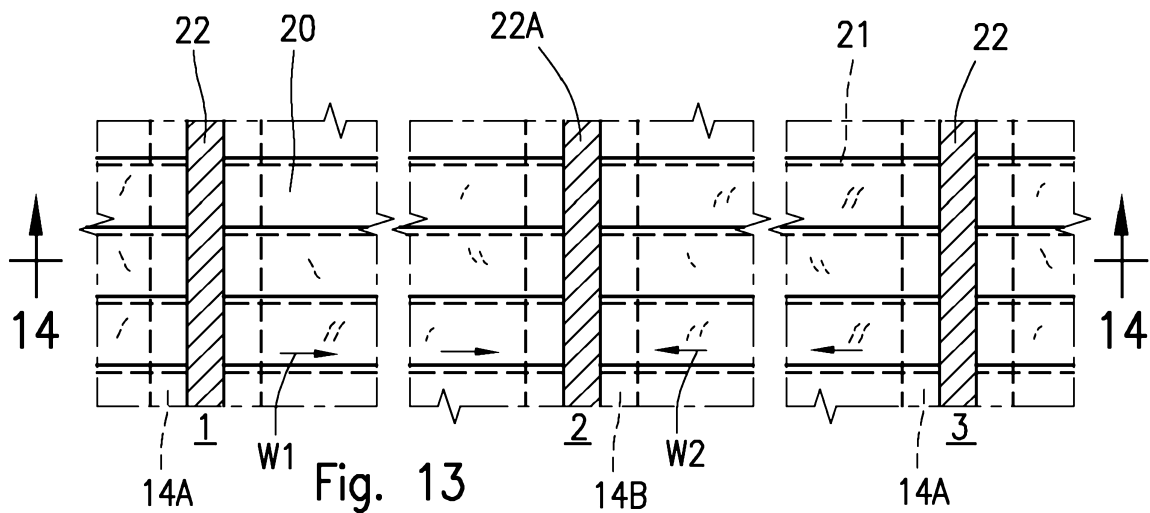

Fig. 13

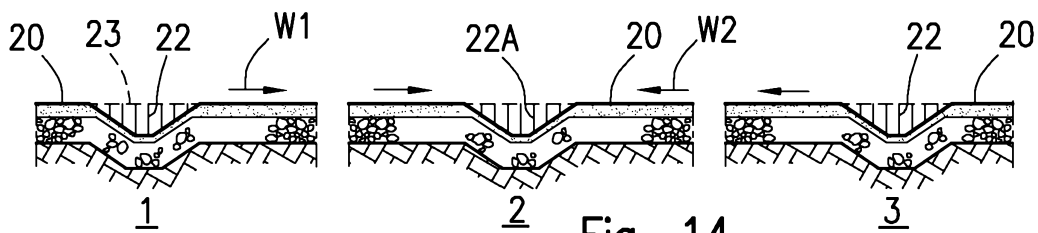

Fig. 14

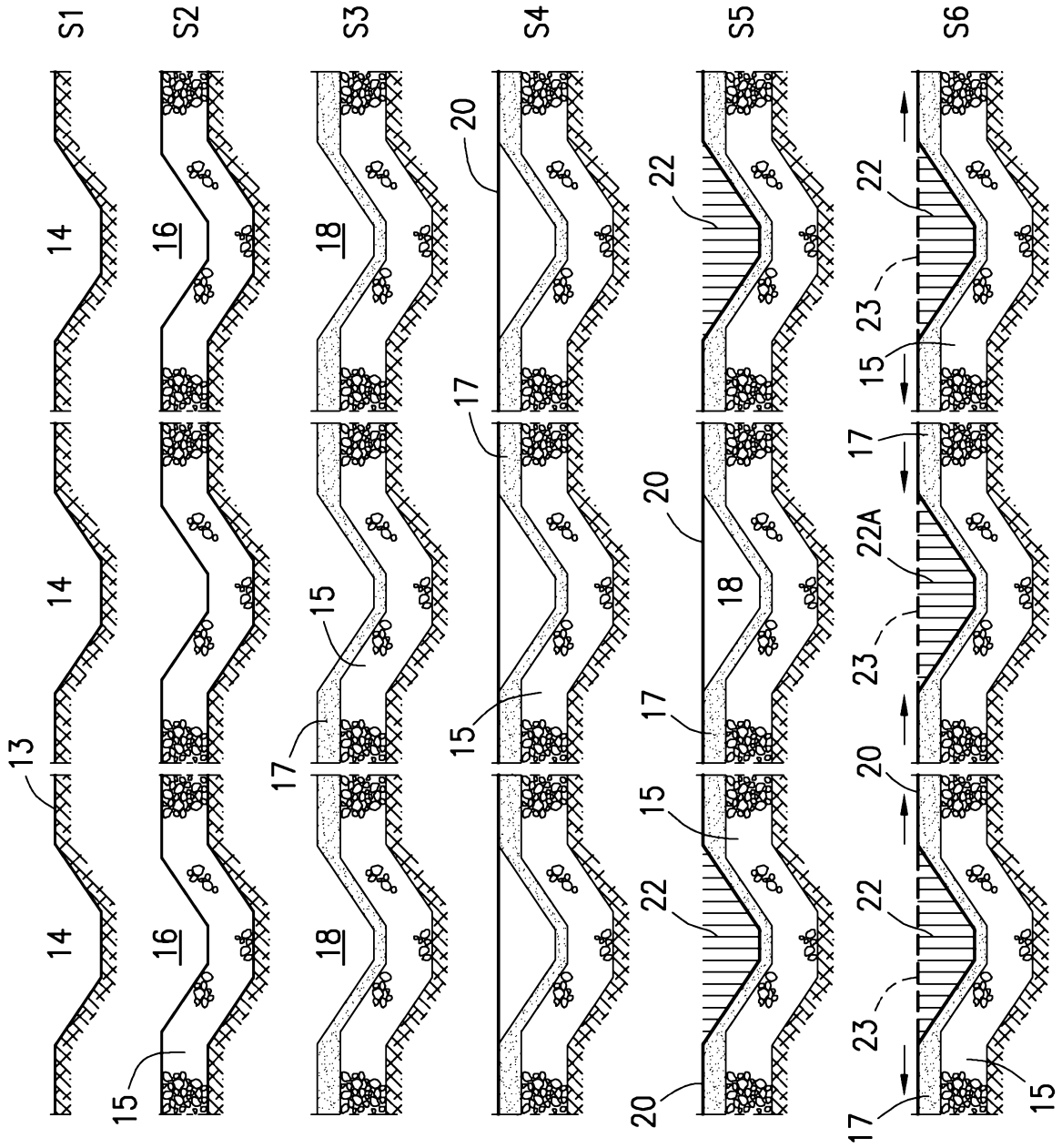

Fig. 15