

HUNTLEY & CAVEN.

Cooking Stove.

No. 30,733.

Patented Nov. 27, 1860.

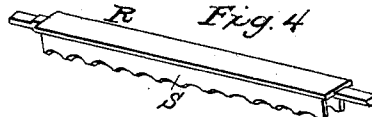
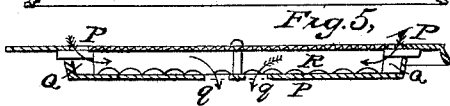
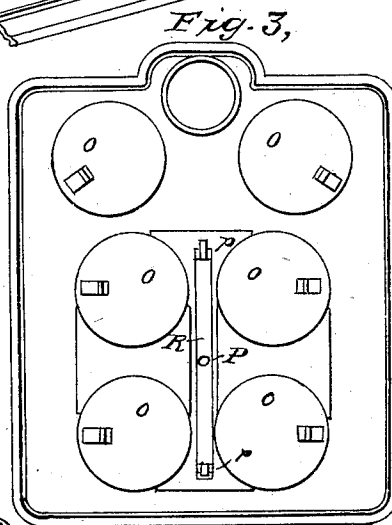
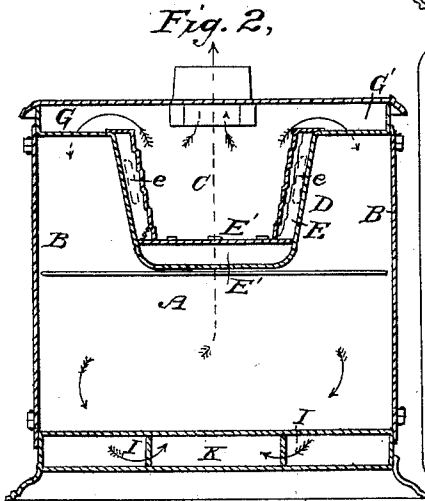
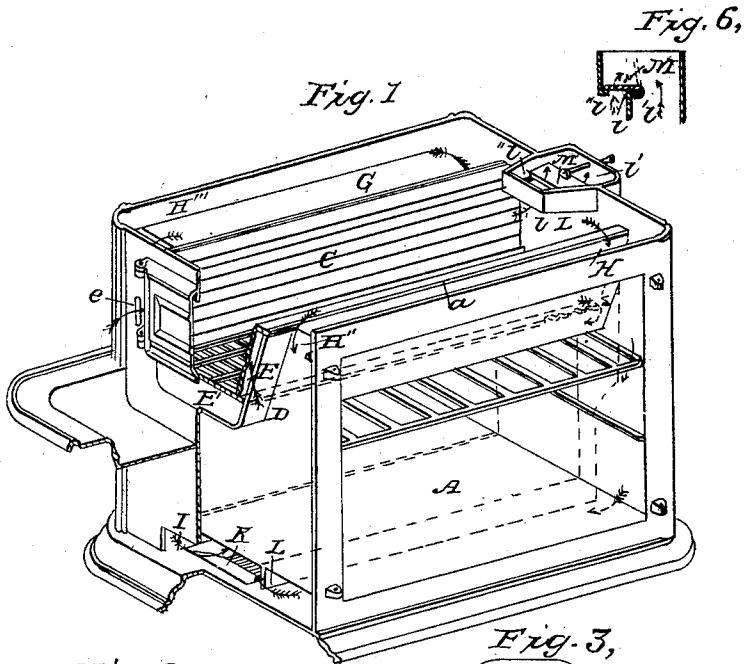

WITNESSES

Staines Knight
Robt. W. Hewrick

INVENTORS;

Huntley & Caven
per Augustus Bolton

UNITED STATES PATENT OFFICE.

HOSEA H. HUNTLEY AND WILLIAM CAVEN, OF CINCINNATI, OHIO.

COOKING-STOVE.

Specification of Letters Patent No. 30,733, dated November 27, 1860.

To all whom it may concern:

Be it known that we, HOSEA H. HUNTLEY and WILLIAM CAVEN, both of Cincinnati, in the county of Hamilton and State of Ohio, have invented certain new and useful Improvements in Cooking-Stoves; and we hereby declare the following to be a full, clear, and exact description of the same, reference being had to the accompanying drawings, making part of this specification.

The said invention relates to a peculiar combination and arrangement of fire chamber, air passages, flues, &c., with respect to the oven and boiling places, having for its object the most effective and uniform disposition of heat for the purposes of cooking.

In the accompanying drawings: Figure 1 is a sectional perspective view of a stove embodying our improvements. Fig. 2 is a cross section, and Fig. 3 a plan of the same. Fig. 4 represents a detached part of center piece. Fig. 5 is a longitudinal section of center piece. Fig. 6 is a vertical section of damper and guard.

A is an oven of great capacity, its bottom and sides occupying respectively the entire horizontal and vertical areas of the stove between the flues. This oven is accessible at either side by doors B, which are, singly or collectively of the full size of the oven.

A fire box C extends entirely from front to back of the stove and equidistant or centrally between the sides thereof.

A shell D incloses the sides and bottom of the fire box, so as to form air passages E and an ash pit E'. Apertures *e* in the stove front admit air to passages E. This air, after cooling the hottest portion of the fire box, passes in a highly heated condition through apertures *e'* into the rear end of the ash pit, whence it enters the back portion of the fire chamber, and by stimulating combustion at this part, acts to still further equalize the heat throughout the fire chamber.

From the fire box C and boiling flues G' the products of combustion descend a pair of rear corner flues H, H', and being com-

pelled to pass forward by partitions I, I', in the bottom, meet the gases which have descended a pair of front corner flues H'', H''', and thence pass under the center of the oven in single volume through the exit flue K.

A guard box L projects forward over the rear portion of the fire chamber with which it communicates by an aperture *l*, and with the exit flue by an aperture *l'*. A ledge *l''* around the aperture *l* supports a damper M by means of which a direct communication with the exit may be opened. This guard box L enables the exit nozzle N, and damper M to be brought within the general rectangular limits of the stove, enabling the use of long firewood in a comparatively short stove, and guarding the damper from dislodgment or injury by the fuel.

O are the boiler holes—the entire series of which, is, by this arrangement brought directly and equally over the fire so as to avail the first contact of the flames to each and every boiling place in the most effective and uniform manner possible.

The center piece of the stove top, as customarily constructed, has often to be replaced, in consequence of its sagging from the great heat. This liability we effectually remove by the following mode of construction.

We form our center piece P with a deep longitudinal recess Q to receive a bridge piece R whose ends are securely confined in apertures in the part P and whose middle portion is riveted or bolted to said part P. Flanges S on the under side of the part R enter the recess Q, and, being notched or serrated on their lower edges permit a free circulation of air, and preserve the piece R, of which they form a part, from heat and sagging, the part R by its mode of connection with the part P preventing any sinking of the latter under the effect of heat.

Apertures *p* and *q* through the upper and lower portions of the center piece permit the entrance and passage of cold air through the center piece into the stove. It will be seen that the described disposition of supply passages in connection with a fire box, ar-

55

60

65

70

75

80

85

90

95

100

ranged longitudinally of the stove and mid-way between the sides, and extending from the front to the back of both oven and boiling surface, insures a uniform baking and
5 boiling action at every part.

We claim as new and of our invention herein—

The combination with the central longitudinal fire box C of supply passages *e E e'*
10 arranged to receive external air in front

and admit it to the fire at the rear in the manner and for the purposes set forth.

In testimony of which invention, we hereunto set our hands.

HOSEA H. HUNTLEY.
WM. CAVEN.

Witnesses:

GEO. H. KNIGHT,
FRANCIS MILLWARD.