

July 12, 1966

W. E. REYNOLDS ETAL  
HAIR CUTTING APARATUS WITH ROTARY HAIR CUTTERS HAVING  
OVERLAPPING PATHS OF MOVEMENT

3,260,268

Filed Nov. 28, 1962

3 Sheets-Sheet 1

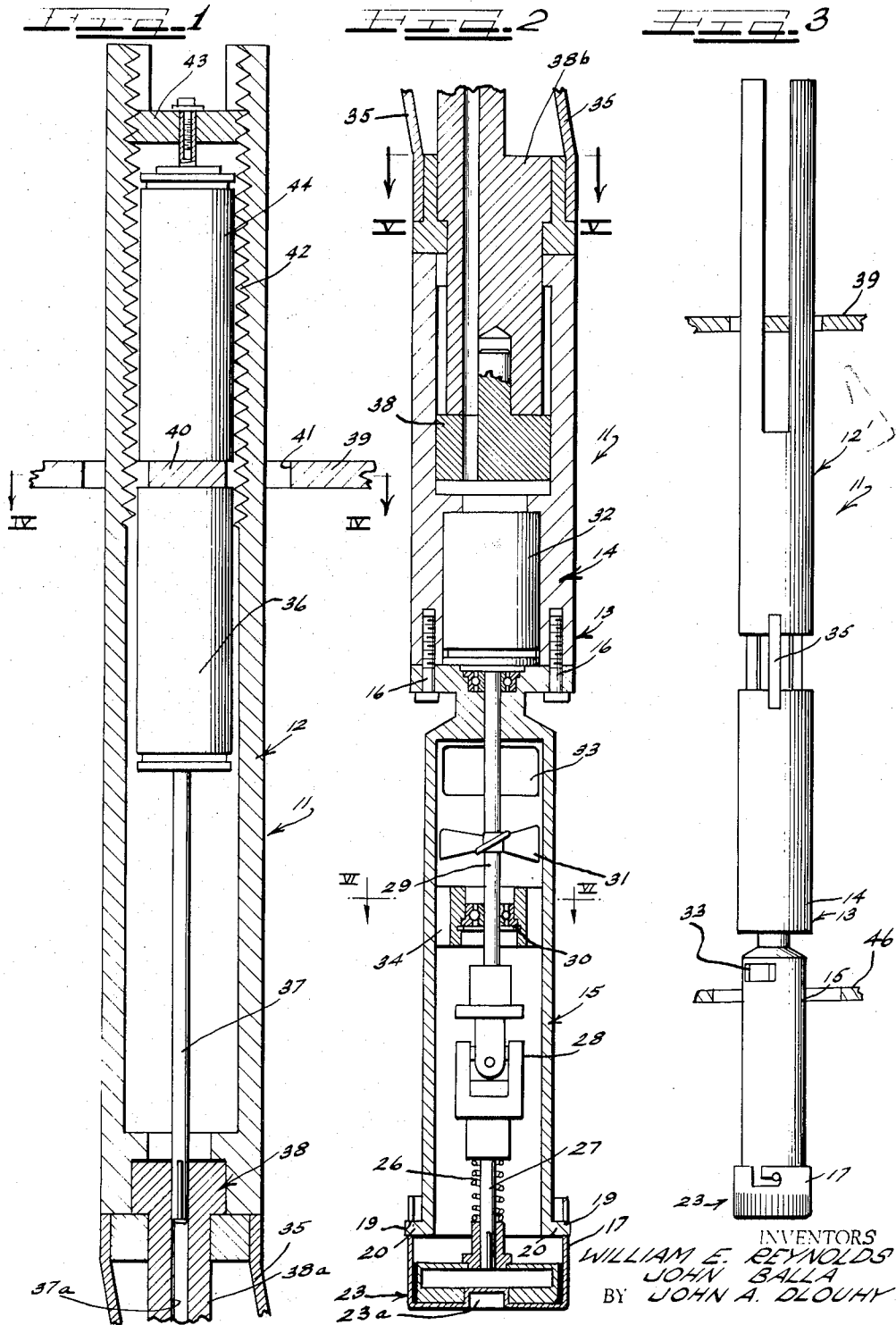

Hill, Sherman, Meroni, Cross & Sampson ATTORNEYS

July 12, 1966

W. E. REYNOLDS ETAL  
HAIR CUTTING APPARATUS WITH ROTARY HAIR CUTTERS HAVING  
OVERLAPPING PATHS OF MOVEMENT

3,260,268

Filed Nov. 28, 1962

3 Sheets-Sheet 2

FIG. 4

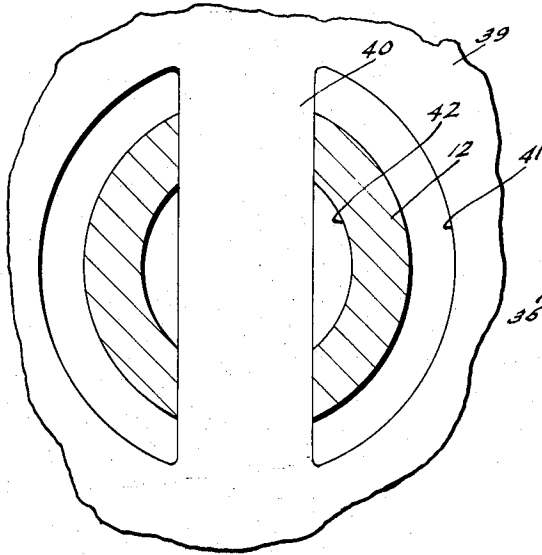

FIG. 5

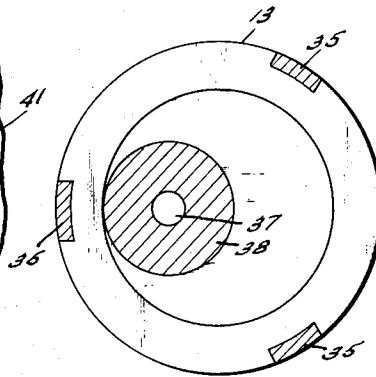

FIG. 6

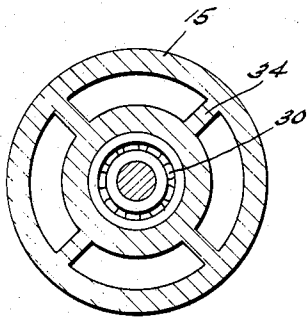

FIG. 7

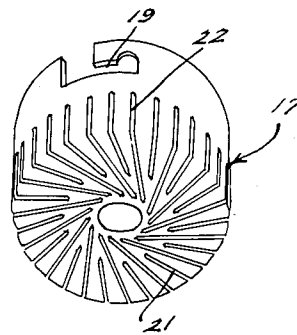
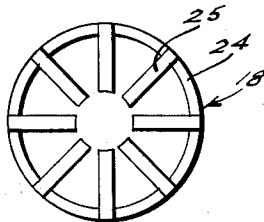

FIG. 8



INVENTORS  
WILLIAM E. REYNOLDS  
JOHN BALLA  
BY JOHN A. DLOUHY  
Att. Sherman, Meroni, Gross & Simpson  
ATTORNEYS

July 12, 1966

W. E. REYNOLDS ET AL  
HAIR CUTTING APPARATUS WITH ROTARY HAIR CUTTERS HAVING  
OVERLAPPING PATHS OF MOVEMENT

3,260,268

Filed Nov. 28, 1962

3 Sheets-Sheet 3

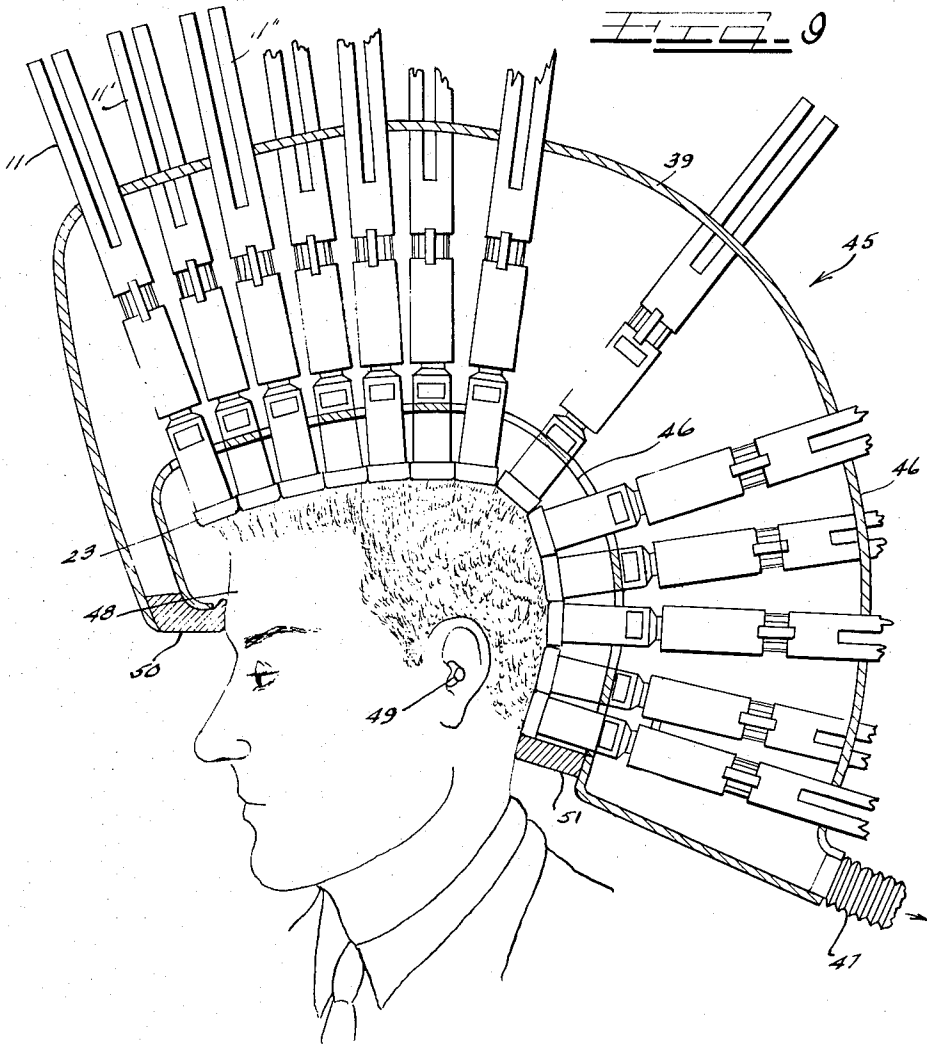

Fig. 9

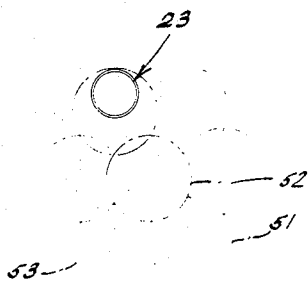

Fig. 10

INVENTORS  
WILLIAM E. REYNOLDS  
JOHN BALLA  
BY JOHN A. DLOUHY

*Still, Sherman, Meroni, Gross & Simpson*  
ATTORNEYS

1

3,260,268

## HAIR CUTTING APPARATUS WITH ROTARY HAIR CUTTERS HAVING OVERLAPPING PATHS OF MOVEMENT

William E. Reynolds, Riverside, John Balla, Argo, and John A. Dlouhy, Oak Park, Ill.; said Reynolds and said Balla assignors to IIT Research Institute, a corporation of Illinois

Filed Nov. 28, 1962, Ser. No. 240,580

4 Claims. (Cl. 132-45)

The present invention relates to improvements in mechanisms for cutting hair and particularly to an improved power driven rotary hair cutter and to a mechanism incorporating a plurality of cutters for simultaneously cutting an entire head of hair.

In providing a cutter which mechanically will cut an entire head of hair it is essential that cutting means be provided which can operate reliably and continuously without attention by the operator. It is also necessary to provide a cutter which will not pull the hair but accomplish a clean smooth cutting operation. The cutter also should be of a construction which is safe so that if it is inadvertently brought into contact with the skin of the individual injury will not result, and the cutter must be free from shock hazard. These and various other requirements are essential in providing a mechanical cutter which is capable of being operated automatically for accomplishing a haircut.

It is accordingly an object of the present invention to provide an individual cutter which is capable of being used in a mechanical assembly containing a plurality of cutters and which requires a minimum of space and yet which can be mechanically driven for intermittent continuous operation without endangering the individual and without creating operational difficulties such as becoming fouled with hair.

A further object of the invention is to provide an improved hair cutter which cuts a small area and which is driven in a repeating path of movement to move its cutting surface over a larger area, such as by a rotary or orbital oscillating movement.

A still further object of the invention is to provide an individual hair cutter which operates to continuously remove the hair ends which have been cut so that it can operate continuously without cleaning and so that the hair ends do not foul the operating mechanism.

A further object of the invention is to provide a hair cutting mechanism or system wherein individual cutters are controllably positionable relative to the surface of a head of hair and operate to move in paths which overlap so as to substantially simultaneously cut an entire head of hair with one operation.

A still further object of the invention is to provide a very compact hair cutter which is capable of being driven in rotation for cutting hair, capable of being controllably positioned relative to a support to be moved in relation to the surface of a head of hair, and capable of being relatively slowly continuously moved in a repeating path of movement to cover an area to be cut.

Other objects, advantages, and features will become more apparent with the teaching of the principles of the invention in connection with the disclosure of the preferred embodiment thereof in the specification, claims and drawings, in which:

FIGURE 1 and FIGURE 2 are respectively upper and lower portions of a cutter with the views being in vertical section taken through the central axis of the cutter and with portions being shown in full view;

FIGURE 3 is a side elevational view of the cutter;

FIGURE 4 is an enlarged horizontal sectional view taken substantially along line IV—IV of FIGURE 1;

FIGURE 5 is an enlarged horizontal sectional view taken substantially along line V—V of FIGURE 2;

2

FIGURE 6 is a horizontal sectional view taken substantially along line VI—VI of FIGURE 2;

FIGURE 7 is a perspective view of the stationary blade of the cutter head;

FIGURE 8 is a bottom plan view of the rotary blade of the cutter head;

FIGURE 9 is a vertical sectional view shown in somewhat schematic form of a cutter assembly for cutting a full head of hair; and

FIGURE 10 is a diagrammatic view showing the paths of travel of a plurality of cutters to overlap and cut an area larger than the individual cutter.

On the drawings:

FIGURES 1-3 show an assembly for cutter 11 adapted for cutting hair and the cutter incorporates an elongated frame or support housing 11 having an upper portion 12 and a lower portion 13, with the upper portion shown in FIGURE 1 and the lower portion in FIGURE 2.

The lower portion 13 has an upper part 14 and a lower part 15. The lower part has an outwardly extending flange at its upper end which receives attaching pins 16 to secure it to the part 14. The upper portion 12 is mounted for vertical reciprocation to adjust the position of the cutter assembly with respect to an individual's head, and the lower portion 13 is moved in an oscillatory path of movement to cover an area larger than the cutting head.

The cutting head includes an outer stationary cup-shaped blade 17, FIGURES 2 and 7, and an inner rotatable blade 18, FIGURES 2 and 8.

The stationary blade 17 has bayonet slots 19 for receiving bayonet pins 20, FIGURE 2, on the lower housing part 15 to support the cutter head. The rotary blade 18 seats within the stationary blade 17 and has a cylindrical body portion 24 with lower radially extending knives or cutting elements 25 that sweep by radial slots 21 in the stationary blade 17. The radial slots also extend upwardly in vertical slots 22, and the blades 25 extend upwardly a distance so that hair entering the slots 21 or 22 is cut and the cut ends are received inside the cutting head. A flow of air is induced upwardly through the head and through the slots so that the cut ends of the hair will be immediately removed from the rotating blade 18 and from the driving portions to permit continuous operation without fouling. A socket 23a is provided in the center of the stationary blade 17 for mounting a miniature sized detector to generate a position signal for positioning the cutter relative to an individual's head.

The rotatable cutting blade 18 is driven by a lower shaft 27 which drivingly connects to the blade 18, and a coil compression spring 26 surrounds the shaft 27 to lightly urge the rotary blade 18 into cutting contact with the stationary blade 17. The shaft 27 slides relatively axially with respect to the blade 18.

The drive shaft 27 is driven through a universal joint 28 which is driven by an upper drive shaft 29 connecting to a drive motor 32.

Because of the small size which must be maintained for the cutter assembly 11, a small drive motor 32 is used and, for example, a 28 volt 400 cycle motor may be employed. This permits the use of a standard component and the low voltage eliminates danger to the individual from accidental shorts in the electrical supply circuit. For purposes of convenience the wires supplying electricity to the motors have been omitted from the drawings but the connection for these and their position will be readily understood and appreciated by those skilled in the art.

The upper drive shaft 28 leading from the motor 32 is supported in a bearing 30 within the tubular housing part 15 on a spider 34, FIGURES 2 and 6, to provide passages for the upward flow of air for removing hair ends.

3

The drive shaft 29 carries a fan blade 31 which causes the upward flow of air. The tubular housing part 15 has one or more lateral hair outlet openings 33, FIGURES 2 and 3, which discharge hair from the cutter 11. This discharge will usually be into a space between shells of the helmet 45 as will be explained in further detail in connection with FIGURE 9.

The cutter runs at a relatively high speed such as on the order of 6,500 revolutions per minute which provides rapid sure cutting and provides an adequate flow of air with a relatively small fan, to carry away the cut hair.

The cutting head 23 is moved in a path of movement to cover an area larger than the cutting head, and this path is continually repeated during normal operation so that the cutter repeatedly sweeps over the area being cut, although the movement is relatively slow. This movement is preferably in an oscillatory rotary path and the head carried on the lower housing part 15 supported on the housing part 14 is moved relative to the upper housing part 12. In other words, the entire lower housing part 13 moves in an orbital path while remaining parallel to the axis of the cutter 11. The lower portion 13 of the housing is stabilized on the upper portion by flexible spring connectors 35, FIGURES 1-3 and 5. These spring connectors are suitably secured such as by brazing or welding at their ends to the upper housing part 12 and lower housing part 13. The lower part 13 is driven in oscillation by drive shaft 37 driven by a motor 36 secured within the tubular upper housing part 12. The shaft 37 is concentric with the upper housing part and connects to a drive shaft member 38, FIGURE 5, which has a lower portion 38b journaled in and eccentric with respect to the lower housing part 13. The shaft 37 is keyed to an upper portion 38a of the drive shaft member 38 and vertically slides therein. The motor 36 has a slow rate of rotation and may drive through a gear reduction. The motor 36 must be capable of being synchronized with other motors so that adjacent cutters can oscillate in unison to provide the cutting pattern of FIGURE 10.

The vertical positioning of the cutter relative to its support wall 39 is accomplished by a motor 44. The support wall 39 has an opening 41 therein and the upper end of the housing part 12 is bifurcated to extend through the sides of the opening 41 which is separated by a bridging portion 40. The bridging portion 40 supports the motor 44 which rotatably drives a nut 43 in threaded engagement with internal threads 42 within the tubular housing part 12. The motor 44 is controllably driven in slow rotation by a suitable control circuit and is reversible to operate in either direction to raise or lower the cutter assembly 11.

FIGURE 9 illustrates a plurality of cutter assemblies 11, 11', and 11'' supported on the helmet 45. The helmet is adapted to be located in a pre-determined position relative to the head 48 of an individual. For this purpose side first positioners 49 are provided which are radially retractable relative to the helmet and are movable inwardly to engage within the ear of the individual. Separate retractable inwardly spring biased positioners 49 are on each side of the helmet to engage in the ears. A second positioner 50 is positioned on the front of the helmet to be engaged by the forehead of an individual. This positively positions the helmet relative to the individual's head and will permit locating the helmet in the exact position for successive haircuts. A flexible shield 51 is at the rear of the helmet.

When the helmet is in position each of the cutters is moved to a pre-determined radial position relative to the surface of the head of the individual. Such distance can be determined by the distance the cutter is moved inwardly from the helmet inasmuch as the helmet is in a known position, having been located by the positioning members 49 and 50.

When the cutters are in their pre-determined position to cut the hair over the complete head 48, to a pre-

4

determined pattern or style, they each move in an oscillating path as illustrated by the paths 51, 52 and 53 in FIGURE 10. The paths are overlapping so that the complete head area is cut. The cutters are synchronized in their oscillating movement so that they will not interfere and this may be readily accomplished by electrically synchronizing the oscillating motors 36. These motors may be servo motors such as 28 volt 400 cycle.

The hair withdrawn from each individual cutter passes into the space between the outer support shell 39 and an inner shell 46, which has holes to accommodate oscillating movement of the lower portions of the cutters. A further flow of air is induced through an exhaust passage 47 which is connected to an exhaust fan and draws air through the space between the helmet shells.

Thus each individual cutter independently drives the rotating cutter blade 18 by operation of the motor 32. The cutter head 23 is oscillated in a rotary path by the servo motor 36 with each of the servo motors for the different cutters being synchronized. The housing for the cutter is positioned axially with respect to the helmet so as to achieve the proper location relative to the head for a pre-determined hair style by operation of the motor 44. The motors 44 may be operated through individual controls or through an automatic control system which positions each cutter in accordance with an input signal determining the hair style desired.

Thus it will be seen that we have provided an improved hair cutting mechanism for mechanically cutting hair and individual cutters which perform in combination to achieve the objectives, advantages and features above set forth. The mechanism is capable of reliably and quickly accomplishing a complete hair cut and is capable of duplicating the performance with complete accuracy.

The drawings and specification present a detailed disclosure of the preferred embodiments of the invention and it is to be understood that the invention is not limited to the specific forms disclosed, but covers all modifications, changes and alternative constructions and methods falling within the scope of the principles taught by the invention.

We claim as our invention:

1. In a mechanism for cutting hair comprising: cutters adapted for cutting hair including cutting heads,

helmet means supporting said cutters and adapted to be positioned at a predetermined location on an individual's head,

first motor means for moving said cutting heads in or out relative to the inside of the helmet in movements toward or away from said individual's head, and

second motor means for repeatedly and continuously moving said cutting heads in an oscillating closed path of movement during normal operation.

2. A mechanism for cutting hair comprising, a plurality of cutters each adapted for cutting hair, a support carrying said cutters in spaced positions so that they will be spaced over the surface of an individual's head, and

drive means on said support simultaneously moving each of said cutters synchronized with respect to each other so that they do not collide in a predetermined orbital path of movement with said paths causing each cutter to cut an area of hair larger than the cutter and with said paths overlapping to cut the area between said cutters so that an overall combined area will be cut by said plurality of cutters to simultaneously effect a complete haircut.

3. A mechanism for cutting hair comprising, a plurality of cutters each having an upper housing and a lower cutting head, helmet means for supporting each of said cutters in spaced positions and adapted to be positioned in a

5

6

predetermined location relative to an individual's head having hair to be cut,  
 each of said cutters including first motor means for moving said cutting heads in or out relative to the inside of the helmet and toward or away from the individual's head, and including second motor means for moving said cutting head in an oscillating closed path to cut an area of hair larger than the cutting head and means for synchronizing each of said first and second motor means to cause each of said cutters to simultaneously move in a predetermined cutting path of noncolliding movement and with said cut areas overlapping so that an entire head of hair will be cut by said cutters.  
 4. A mechanism for cutting hair comprising, a plurality of cutters each having an upper housing and a lower cutting head,  
 helmet means for supporting each of said cutters in spaced positions and adapted to be positioned in a predetermined location relative to an individual's head having hair to be cut,  
 each of said cutters including first motor means for moving said cutting heads in or out relative to the inside of the helmet and toward or away from the individual's head, and including second motor means for moving said cutting heads in an oscillating closed path to cut an area of hair larger than the

cutting head, means for synchronously operating each of said second motor means to move each of said cutting heads in non-colliding cutting paths and with said paths overlapping so that the entire head of hair will be cut by said cutters, and means controlling said first motor means to position each of said cutters relative to the surface of the head so that the hair may be cut at different lengths by each cutter.

**References Cited by the Examiner**

**UNITED STATES PATENTS**

1,238,061	8/1917	Bourdelat	-----	30-133
2,134,609	10/1938	Hay	-----	30-46.4 X
2,598,212	5/1952	Blair	-----	30-133
2,765,796	10/1956	Guenther	-----	132-45
2,972,351	2/1961	Morgan	-----	132-45

**FOREIGN PATENTS**

1,257,104	2/1961	France.
909,065	10/1962	Great Britain.

RICHARD A. GAUDET, *Primary Examiner*.  
 M. S. MEHR, *Examiner*.  
 R. L. FRINKS, J. C. PETERS, *Assistant Examiners*.