

(19) World Intellectual Property Organization
International Bureau



(43) International Publication Date
21 January 2010 (21.01.2010)

PCT

(10) International Publication Number
WO 2010/007565 A2

(51) International Patent Classification:

A61K 9/70 (2006.01) A61B 1/00 (2006.01)
A61M 5/145 (2006.01) A61D 1/00 (2006.01)

(21) International Application Number:

PCT/IB2009/053005

(22) International Filing Date:

10 July 2009 (10.07.2009)

(25) Filing Language:

English

(26) Publication Language:

English

(30) Priority Data:

08160679.0 18 July 2008 (18.07.2008) EP

(71) Applicant (for all designated States except US): **KONINKLIJKE PHILIPS ELECTRONICS N.V.** [NL/NL]; Groenewoudseweg 1, NL-5621 BA Eindhoven (NL).

(72) Inventors; and

(75) Inventors/Applicants (for US only): **KASSIES, Roelf** [NL/NL]; c/o High Tech Campus Building 44, NL-5656 AE Eindhoven (NL). **NISATO, Giovanni** [IT/CH]; c/o High Tech Campus Building 44, NL-5656 AE Eindhoven (NL). **VAN MENSVOORT, Wilhelmus, H., N., M.** [NL/NL]; c/o High Tech Campus Building 44, NL-5656 AE Eindhoven (NL).

(74) Agents: **VAN VELZEN, Maaïke, M.** et al.; High Tech Campus Building 44, NL-5656 AE Eindhoven (NL).

(81) Designated States (unless otherwise indicated, for every kind of national protection available): AE, AG, AL, AM, AO, AT, AU, AZ, BA, BB, BG, BH, BR, BW, BY, BZ, CA, CH, CL, CN, CO, CR, CU, CZ, DE, DK, DM, DO, DZ, EC, EE, EG, ES, FI, GB, GD, GE, GH, GM, GT, HN, HR, HU, ID, IL, IN, IS, JP, KE, KG, KM, KN, KP, KR, KZ, LA, LC, LK, LR, LS, LT, LU, LY, MA, MD, ME, MG, MK, MN, MW, MX, MY, MZ, NA, NG, NI, NO, NZ, OM, PE, PG, PH, PL, PT, RO, RS, RU, SC, SD, SE, SG, SK, SL, SM, ST, SV, SY, TJ, TM, TN, TR, TT, TZ, UA, UG, US, UZ, VC, VN, ZA, ZM, ZW.

(84) Designated States (unless otherwise indicated, for every kind of regional protection available): ARIPO (BW, GH, GM, KE, LS, MW, MZ, NA, SD, SL, SZ, TZ, UG, ZM, ZW), Eurasian (AM, AZ, BY, KG, KZ, MD, RU, TJ, TM), European (AT, BE, BG, CH, CY, CZ, DE, DK, EE, ES, FI, FR, GB, GR, HR, HU, IE, IS, IT, LT, LU, LV, MC, MK, MT, NL, NO, PL, PT, RO, SE, SI, SK, SM, TR), OAPI (BF, BJ, CF, CG, CI, CM, GA, GN, GQ, GW, ML, MR, NE, SN, TD, TG).

Published:

— without international search report and to be republished upon receipt of that report (Rule 48.2(g))

(54) Title: DRUG DELIVERY GARMENT

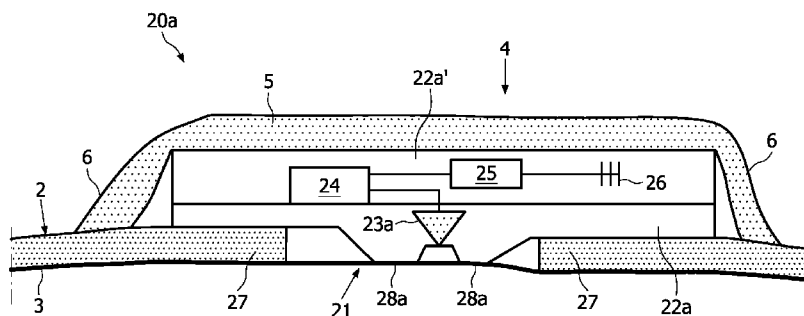

FIG. 2A

(57) Abstract: Drug delivery device (1, 11, 31, 41, 51) comprising a garment (2, 12, 32, 42, 52), such as a sock, T-shirt, or under-pants, comprising at least one pocket (4, 14) encasing at least one drug dispenser (20a, 20b, 20c) with an outlet (23a, 23b, 23c), such as a jet nozzle, in line with an opening (21) in the pocket. The garment (2, 12) is at least partly made of a stretchable fabric. When worn, the outlet can face the skin of a patient and drug delivery can take place.

WO 2010/007565 A2

Drug delivery garment

FIELD OF THE INVENTION

The present invention relates to a drug delivery device comprising a garment carrying a drug dispenser.

5 BACKGROUND OF THE INVENTION

While most drugs are delivered orally, a substantial number of drugs cannot be administered in such a way. For example, the treatments of diabetes, genetic disorders, and novel cancer treatments drugs are typically based on (poly)peptides, which are destroyed in the gastro-intestinal tract. For these drugs the preferred delivery route is usually injection,
10 and appropriate formulations need to be developed or tuned to optimize therapeutic effect, which can be highly dependent on the patient and can vary during time.

One of the methods for realizing a continuous delivery of medication is transdermal drug delivery. To this end, passive patches are often used for delivering medication through the skin by passive diffusion. These patches often use adhesives to
15 adhere to the skin. This can cause skin irritation. Active transdermal systems also exist, using various kinds of physical principles to enhance the drug transport through the skin.

Instead of patches, garments are also used for transdermal drug delivery. DE 198 10 951 discloses the use of a T-shirt to deliver a drug which is absorbed in the fabric of the garment. The problem with this system is that the delivery is not controllable and only
20 part of the drug compound is actually used. Absorption by the fabric may slow down absorption by the patient's skin.

SUMMARY OF THE INVENTION

It is an object of the invention to provide a drug delivery system that enables
25 controlled and adjustable drug delivery via a patient's skin.

The object of the invention is achieved with a drug delivery device comprising a garment comprising at least one pocket encasing at least one drug dispenser with an outlet in line with an opening in the pocket. This way, the patient can carry the drug delivery device continuously with him in a comfortable way, without the need of using patches. Via the

opening in the garment, the dispenser directly faces or contacts the patient's skin, so the drug can be delivered directly and effectively, without being hindered by absorption of the drug by the fabric of the garment.

To obtain good contact between the drug dispenser and the patient's skin, the garment can for example wholly or partly be made of a stretchable fabric. Suitable fabrics or textiles are cotton, polyester or polyamide textile, linen, wool or mixtures thereof.

The drug dispenser can for example comprise one or more jet dispensers, for instance thermal droplet jet dispensers, which are particularly suitable for low speed jetting, or piezoelectric droplet dispensers, which can also be used for high speed jetting (above 30 m/s). High speed jet dispensers are particularly suitable for intradermal or subcutaneous administration, requiring the medicament to be shot through the skin barrier. Low speed injectors can be used for topical or transdermal administration, when the medicament passes the skin by diffusion. Optionally a combination of high speed and low speed jet dispensers can be used. With jet dispensers, a wide range of drug molecules can be dispensed.

The use of such inkjet-related technology jet dispensers, allows careful and accurate control of distribution of the medicament to the target. Exact dosing of the medicament can be achieved. In piezoelectric jet dispensers, an activating pulse induces movement of a piezoelectric transducer changing the volume of a chamber containing liquid to be jetted. The volume change of the chamber generates pressure for propelling a drop out of a nozzle. By adjusting the chamber configuration the velocity of the jetted drops can be increased. Passing the nozzles, the medicament can be accelerated to a velocity which is sufficient to penetrate the patient skin. To this end, the velocity can be increased to more than 30 m/s, e.g., to a velocity of 50 – 150 m/s.

The jets can be generated by actuators located at each individual nozzle, e.g., by piezo actuators, or by a central pressure generating system in combination with electronically controlled valves.

The nozzles of the jet dispenser can have any suitably sized opening, e.g., having a diameter of 30 – 200 μm , for instance about 50 μm .

Alternatively or additionally, the drug dispenser can comprise one or more iontophoretic dispensers and / or micro-needles coupled to a reservoir and a pump. In case of micro-needles, a stretchable fabric can be used to apply a pressure on the drug delivery device to maintain the micro-needles inserted in the stratum corneum. Using micro-needles, a wide range of drug molecules can be dispensed.

For hygienic reasons, the drug delivery device can have a replaceable part comprising a skin contacting section with the one or more nozzles, and a permanent part comprising a connection section for connection of the replaceable part, e.g. by insertion. The replaceable part can for example be a replaceable cartridge encasing the drug reservoir. The power module and control unit can be located in the permanent part. Optionally, the cartridges are refillable.

To secure the drug dispenser to the garment, the opening in the pocket can be defined by a rim or edge attached to the drug dispenser.

Optionally, the garment can be designed to enclose a body part, and for instance be a sock, an underpants, a legging, a panty, a shirt, a T-shirt, a pullover, a cap, etc. Alternatively, the garment can be designed to lay or hang over a body part, like a scarf or waistcoat, e.g., being carried by a strap or belt.

To allow remote control and/or remote monitoring of the drug delivery device, the drug delivery device can be provided with a wireless communication module and a signal emitter / receiver, such as an antenna. The wireless module can for example be a Bluetooth®, infrared, near-field communication, ultra wide band, or IEEE 802.11 module.

The drug delivery device according to the present invention can for instance be used for parenteral drug administration, such as transdermal or needle-free subcutaneous application. The device can for instance be used with the treatment of diabetes for delivery of insulin or GLP-1 analogues. It can also be used with the treatment of neurodegenerative diseases, such as Parkinson's disease for the delivery of dopamine receptor agonists; with the treatment of multiple sclerosis for the delivery of interferone; with pain management as a patient controlled analgesia (PCA) device; or with the treatment of cancer, e.g., for the delivery of therapeutic agents based on monoclonal antibodies.

BRIEF DESCRIPTION OF THE DRAWINGS

The present invention will be elucidated with reference to the figures wherein:

Fig. 1 shows two embodiments of a drug delivery device according to the present invention;

Fig. 2a shows in cross section a pocket with a drug dispenser as used in the drug delivery devices of Fig. 1;

Fig. 2b shows a further embodiment of a drug delivery devices according to the invention;

Fig. 2c shows a further alternative embodiment of a drug delivery devices according to the invention;

Fig 3 shows a further alternative embodiment of a drug delivery device according to the present invention;

5 Fig. 4 shows a further alternative embodiment of a drug delivery device according to the present invention;

Fig. 5 shows a further alternative embodiment of a drug delivery device according to the present invention.

10 DETAILED DESCRIPTION OF EMBODIMENTS

Figure 1 shows a first drug delivery device 1 comprising a sock 2 worn by a user 3. The sock comprises a pocket 4 encasing a drug dispenser (see Figure 2A). A second drug delivery device 11 comprising an underpants 12 worn by a user 13 is also shown in the Figure 1 and is also provided with a pocket 14 comprising a drug dispenser (see Figure 2A).
15 The pockets 4, 14 comprise a fabric cover 5, 15 sewed along its edges 6, 16 to the sock 2 or the underpants 12 respectively. The upper edge 7, 17 of the pocket 4, 14 is left open, so the contents of the pocket 4, 14 can be taken out or put back in if and when so desired.

Figure 2a shows in cross section the drug dispenser 20a contained within the pocket 4 of sock 2 of Figure 1. An identical dispenser 20a can be used within pocket 14 of
20 underpants 12 of Figure 1. The fabric cover 5 covers an opening 21 in the sock 2. The drug dispenser 20a comprises a replaceable drug reservoir 22a, shaped as a cartridge which can be clicked onto a permanent part 22a' encasing a jet injection control unit 24, a wireless communication module 25 and an antenna 26 for receiving remote control commands and for exchanging information with a remote receiver. On its side facing the skin of user 3, the
25 replaceable drug reservoir 22a is provided with a jet nozzle 23a, operatively connected to the jet injection control unit 24 within the permanent part 22a'. The jet nozzle 23a is located within the scope of opening 21 in sock 2. The injection control unit 24 can be programmed to activate the nozzle 23a to jet a dose of the contained drug according to a predetermined time pattern. Edge 27 of the opening 21 in the sock 2 is attached to the wall of the reservoir 22a,
30 for instance by gluing. A circular rim 28a surrounds the nozzle 23a to maintain a distance between the nozzle 23a and the patient's skin 3.

Figures 2b and 2c show alternative embodiments which differ from the embodiment of Figure 2a in that a different dispenser type is used. Parts of these

embodiments which are the same as corresponding parts of the embodiment in Figure 2A are indicated with the same reference numbers.

Figure 2b shows an embodiment 20b having a bulge 28b contacting the patients skin 3. The bulge 28b is provided with an array of micro-needles 23b for dispensing the drug from drug reservoir 22b. The stretchable fabric of cover 5 gently presses the micro-needles 23b into the stratum corneum of the patients skin 3.

The embodiment of Figure 2c comprises a drug reservoir 22c with iontophoretic electrodes 23c for dispensing the drug. The iontophoretic electrodes 23c are linked to a power source 29 under the control of control unit 24.

Figures 3, 4 and 5 shows further possible embodiments 31, 41, 51 of drug delivery devices according to the invention. In these embodiments, the devices 31, 41, 51 hang over the skin of a patient 3 and are in contact with the skin of the patient 3 by the effect of gravity and by outer garment worn over the devices 31, 41, 51. The drug delivery device 31 in Figure 3 comprises a fabric section 32 having a pocket stitched on its side contacting the patient 3. The fabric section 32 is carried by a chain or band 33 hanging around the neck of patient 3.

In Figure 4, drug delivery device 41 is shaped as a scarf 42 hanging over the shoulders of the patient 3.

In Figure 5, drug delivery device 51 is designed as a waistcoat, with a fabric section 52 hanging over the lower back of a patient 3, carried by a belt 53 hanging around the neck and over the shoulders of the patient 3. On its surface contacting the skin of the patient 3, the fabric section 52 comprises a pocket cover with an opening through which a jet nozzle of a drug dispenser is directed to the patient 3.

While the invention has been illustrated and described in detail in the drawings and foregoing description, such illustration and description are to be considered illustrative or exemplary and not restrictive. The invention is not limited to the disclosed embodiments. Other variations to the disclosed embodiments can be understood and effected by those skilled in the art in practicing the claimed invention, from a study of the drawings, the disclosure, and the appended claims. In the claims, the word "comprising" does not exclude other elements or steps, and the indefinite article "a" or "an" does not exclude a plurality. A single processor or other unit may fulfill the functions of several items recited in the claims. The mere fact that certain measures are recited in mutually different dependent claims does not indicate that a combination of these measures cannot be used to advantage. Any reference signs in the claims should not be construed as limiting the scope.

CLAIMS:

1. Drug delivery device (1, 11, 31, 41, 51) comprising a garment (2, 12, 32, 42, 52) comprising at least one pocket (4, 14) encasing at least one drug dispenser (20a, 20b, 20c) with an outlet (23a, 23b, 23c) in line with an opening (21) in the pocket.
- 5 2. Drug delivery device according to claim 1 wherein the garment (2, 12) is at least partly made of a stretchable fabric.
3. Drug delivery device according to claim 1 or 2 wherein at least one drug dispenser (23a) is a jet dispenser.
- 10 4. Drug delivery device according to claim 3 wherein the at least one jet dispenser is a piezoelectric jet dispenser.
5. Drug delivery device according to claim 1 wherein the at least one drug dispenser comprises an array of micro-needles (23b).
- 15 6. Drug delivery device according to claim 1 wherein the at least one drug dispenser comprises an iontophoretic dispenser (23c).
- 20 7. Drug delivery device according to claim 1 wherein the opening (21) in the pocket (4, 14) is defined by a rim attached to the drug dispenser.
8. Drug delivery device according to claim 1 wherein the garment (2, 12) is designed to enclose a body part.
- 25 9. Drug delivery device according to claim 1 wherein the garment (32, 42, 52) is designed to hang over a body part.

10. Drug delivery device according to claim 1 wherein the drug delivery device comprises a replaceable part (22a) comprising a skin contacting section with the one or more nozzles (23a), and a permanent part (22a') comprising a connection section for connection of the replaceable part (22a).

5

11. Drug delivery device according to claim 10 wherein the replaceable part (22a) comprises a refillable drug reservoir.

1/5

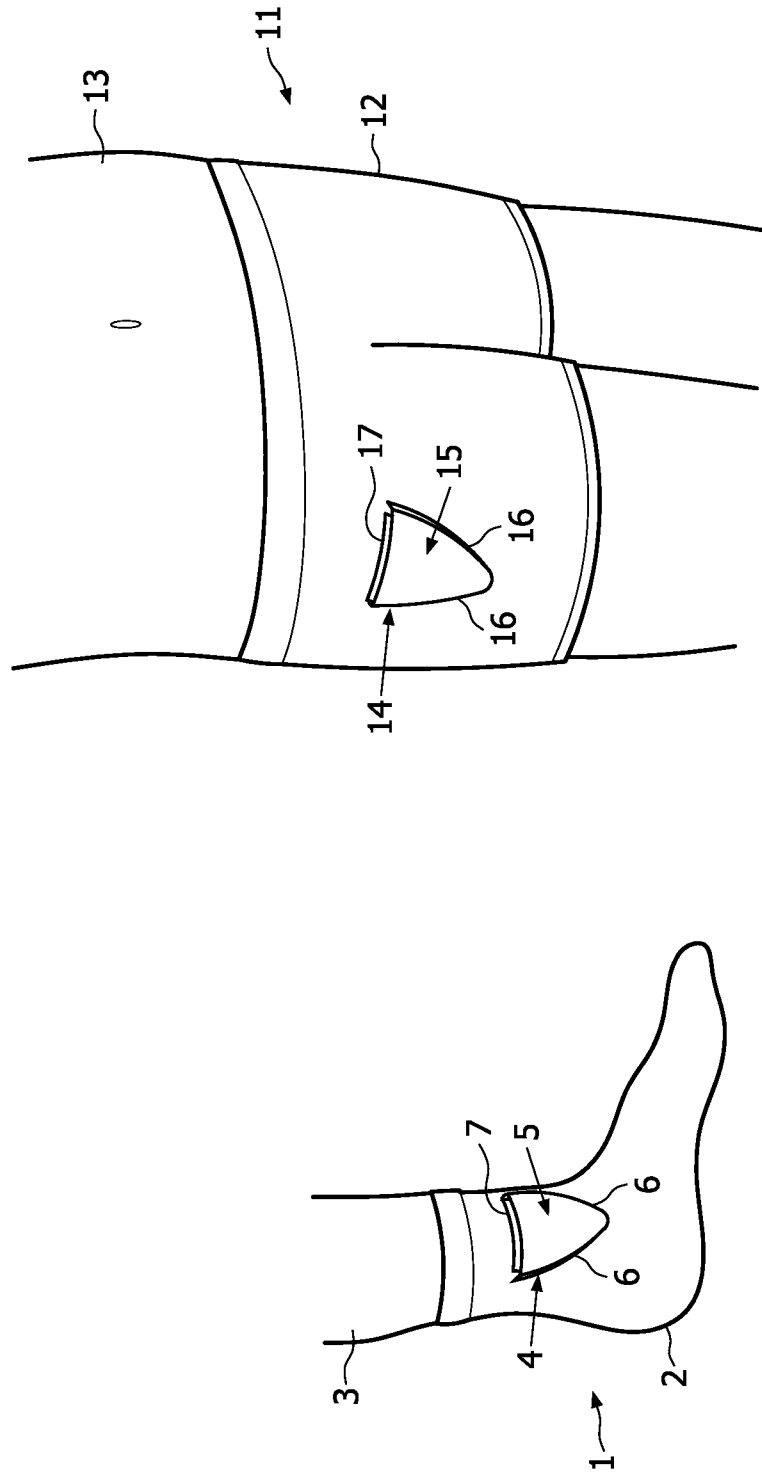

FIG. 1

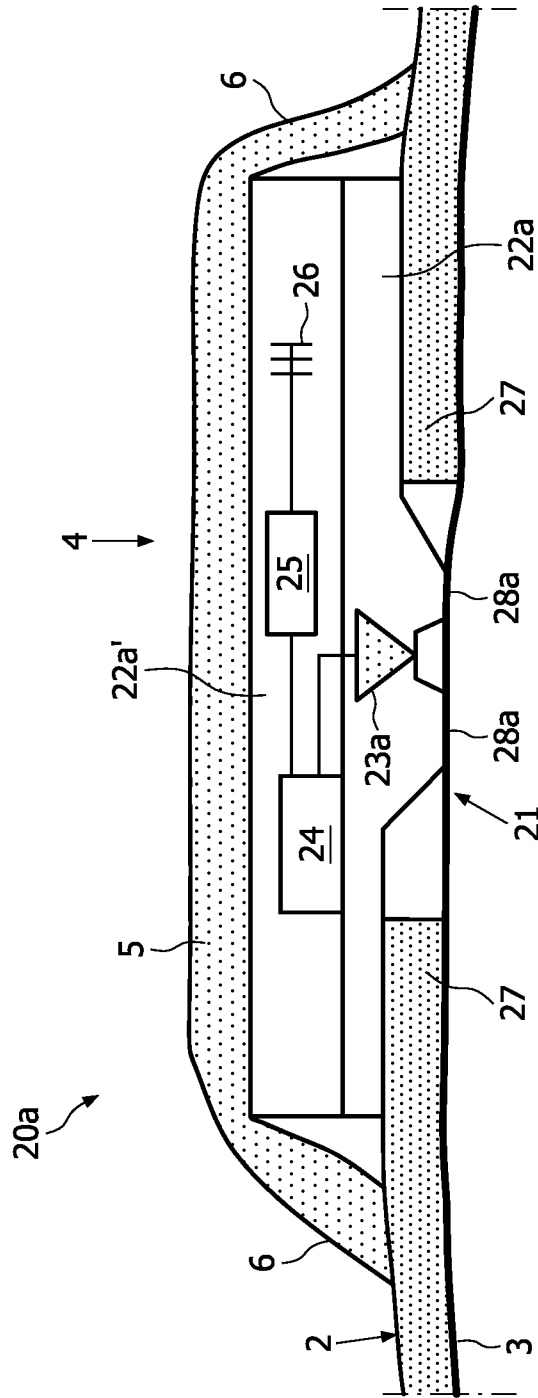

FIG. 2A

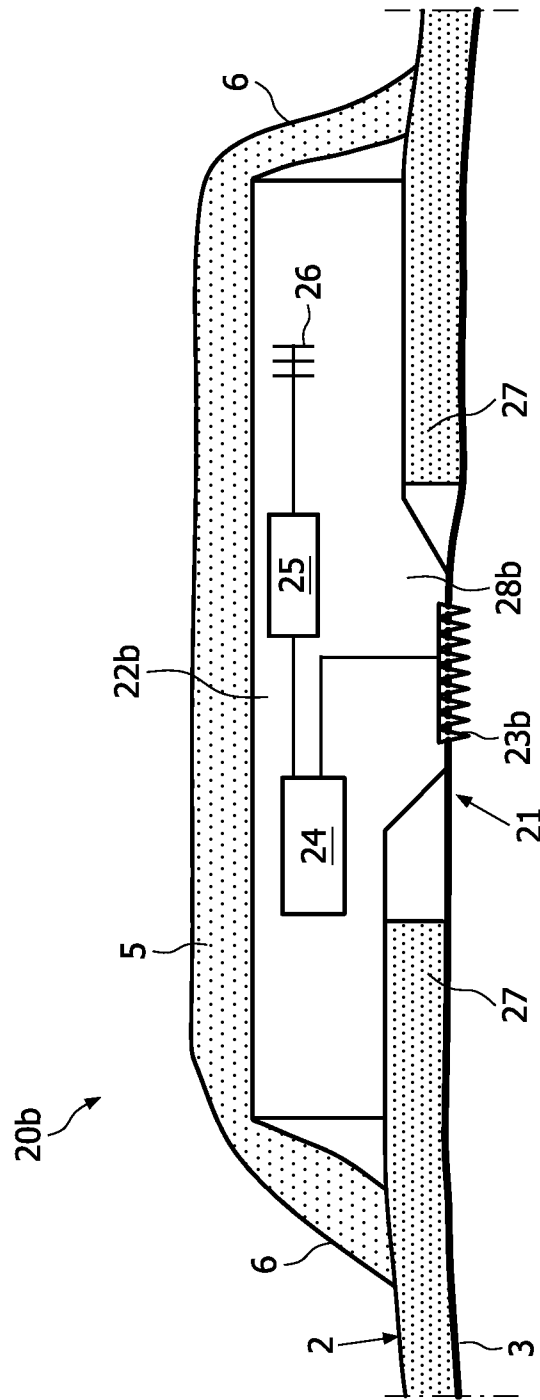

FIG. 2B

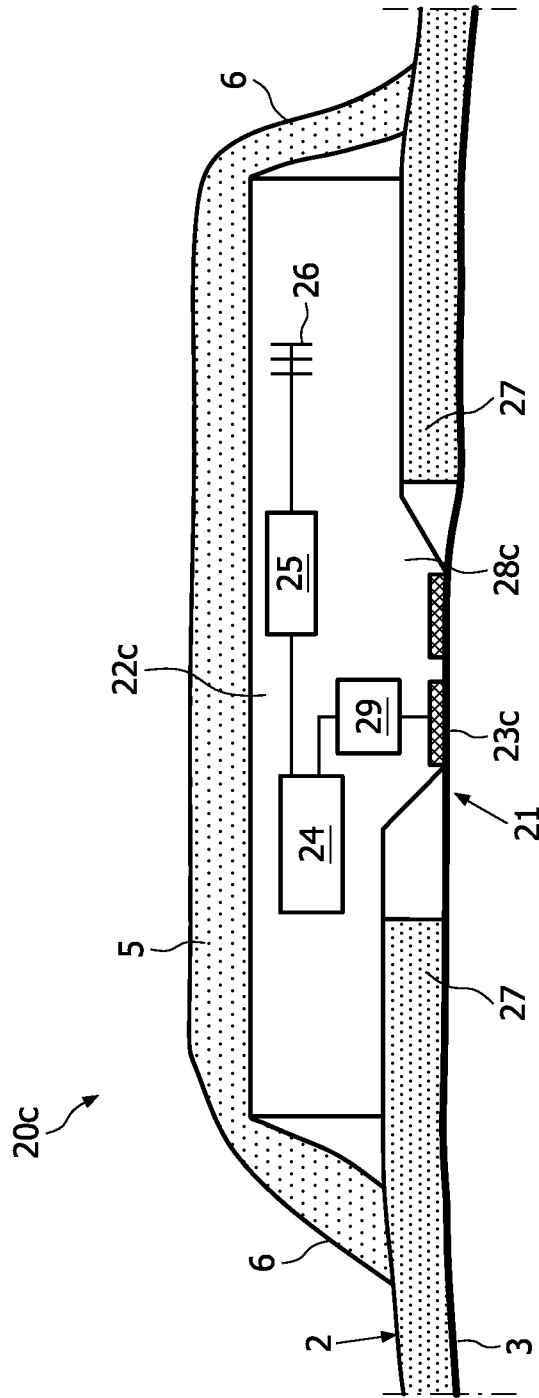

FIG. 2C

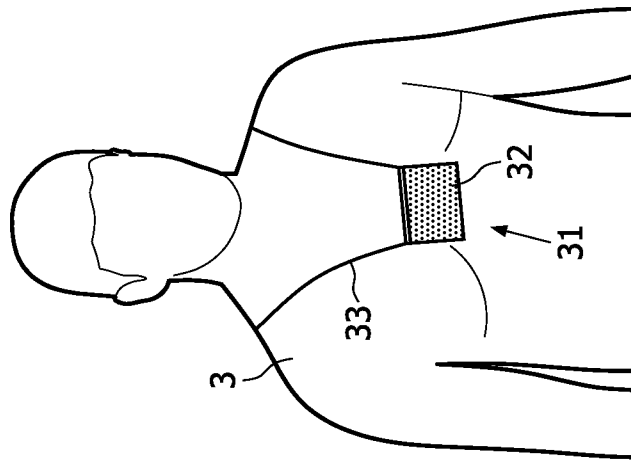

FIG. 3

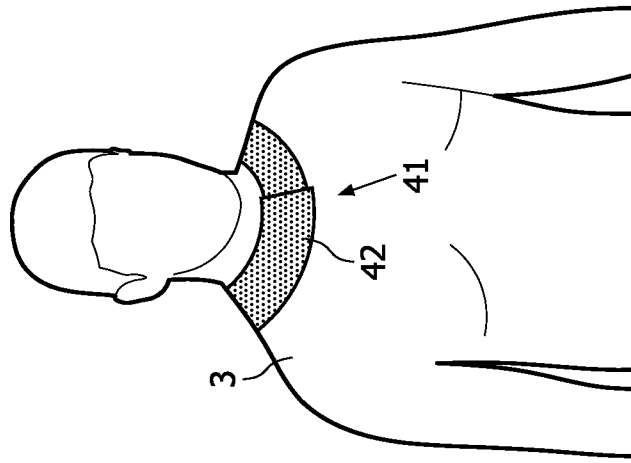

FIG. 4

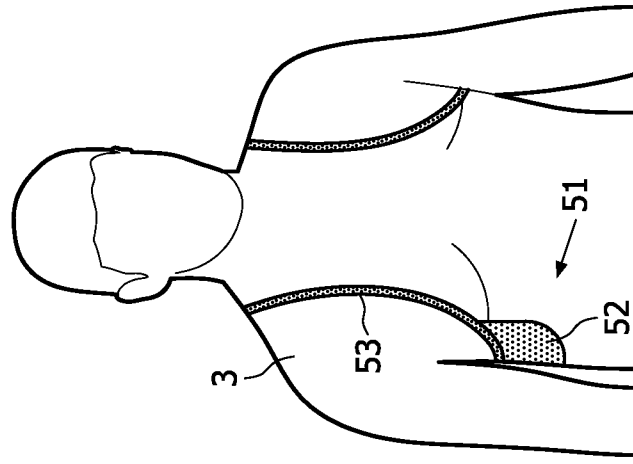

FIG. 5