

(No Model.)

O. H. ROBERTSON.
WAGON JACK.

No. 455,357.

Patented July 7, 1891.

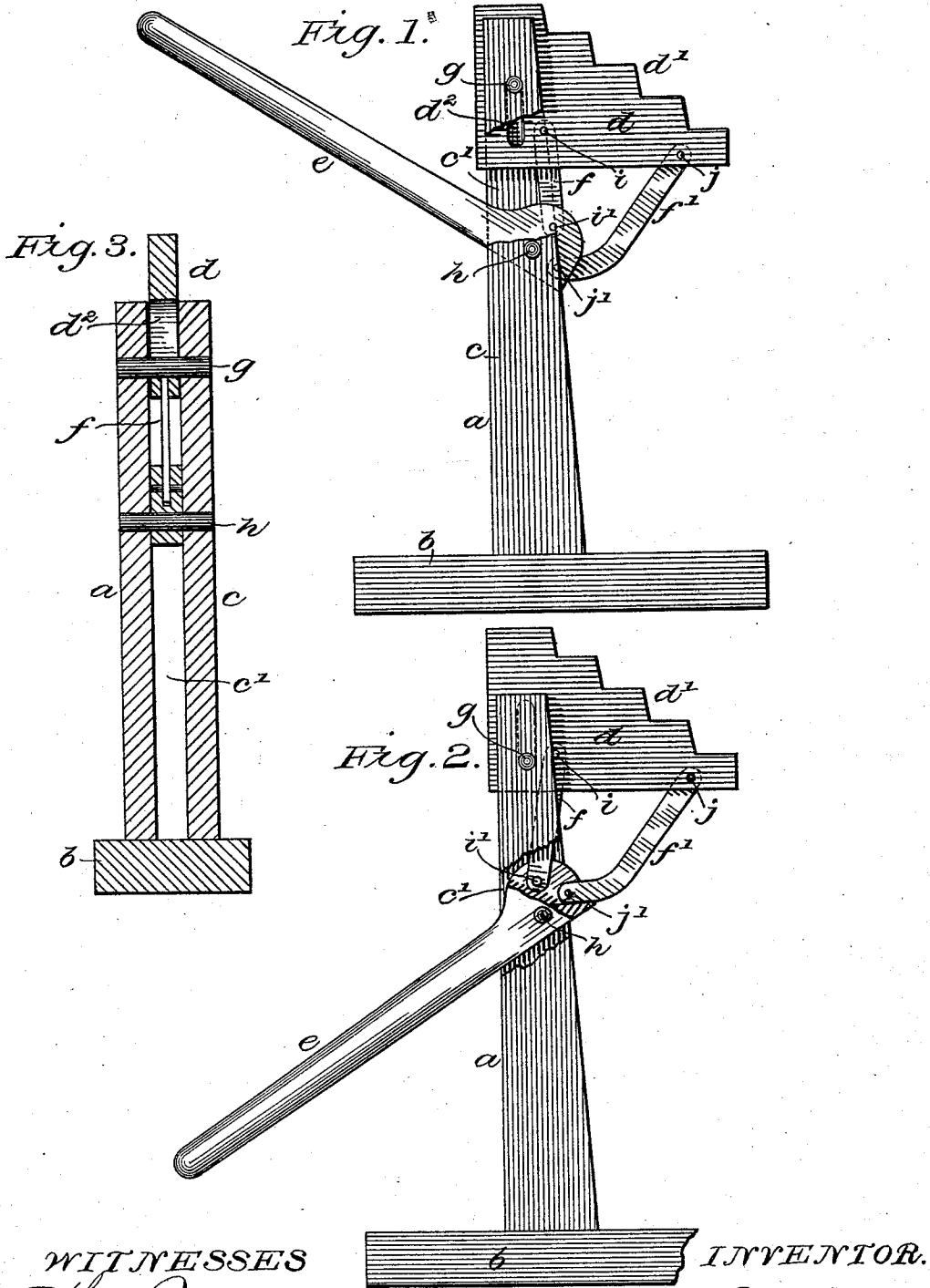

WITNESSES
Wm. Messer,
W. S. Jenkins,

INVENTOR.
Oliver H. Robertson.
By *Simonds & Burdett,*
attys

UNITED STATES PATENT OFFICE.

OLIVER H. ROBERTSON, OF FORESTVILLE, CONNECTICUT.

WAGON-JACK.

SPECIFICATION forming part of Letters Patent No. 455,357, dated July 7, 1891.

Application filed May 11, 1891. Serial No. 392,310. (No model.)

To all whom it may concern:

Be it known that I, OLIVER H. ROBERTSON, of Forestville, in the county of Hartford and State of Connecticut, have invented certain new and useful Improvements in Wagon-Jacks, of which the following is a full, clear, and exact description, whereby any one skilled in the art can make and use the same.

The object of the invention is to provide a device for lifting the wheel of a wagon from the ground, so as to allow it to be removed from the axle for cleaning, oiling, or other purpose, the parts of the device being comparatively few, simple in construction, and positive in action.

To this end my invention consists in the details of the several parts making up the lifting-jack as a whole, and in their combination, as more particularly hereinafter described, and pointed out in the claims.

Referring to the drawings, Figure 1 is a detail side view of the wagon-jack embodying my invention, showing the lever raised, and with parts of the standard broken away to show construction. Fig. 2 is a detail side view of the same, with the lever depressed and the lifting-block raised to the upper limit of its play. Fig. 3 is a detail view in cross-section through the upper part of the lifting-jack.

In the accompanying drawings, the letter *a* denotes the frame of the device, composed of a suitable foot *b* and standard *c*, the latter supporting the lifting-block *d* and the parts, as lever *e* and links *f f'*, that compose the block-operating mechanism.

The base and standard may be of any convenient and suitable material, as metal cast to shape, or of wood, with the upper surface of an irregular outline, forming a series of shoulders at different levels. This block is connected with the standard by a pin *g*, that passes through a slot *d²* in the lifting-block, so as to guide the latter in its up-and-down movements. At a point below the lifting-block the lever *e* is pivoted to the standard by a fulcrum-pin *h*, the shorter end of this lever underlying the block. There extends between the end of the lever and the lifting-block two links *f f'*, connecting the lever and the lifting-block, one being pivoted aside or separate from the other to the lever and

block. The pivot-pins *i i'* that connect these links to the block and to the lever, respectively, are so arranged that when the block is at the upper limit of its play the pin *i'* will be thrown over beyond a line drawn from the fulcrum-pin *h* to the pin *i*, thus tending to lock the parts in that position. The link *f'* is also so connected by pins *j j'* to the block and the lever that the latter pin *j'* is also thrown beyond the line drawn between the pin *j* and the fulcrum-pin *h* when the block is lifted. By this means the lever and the block are locked when the latter is at the upper limit of its play, and any load within the limit of the strength of the device is firmly supported on the lifting-jack without any danger that the load will be accidentally dropped from pressure of the weight. These links are located in slots or sockets formed in the respective parts, and the link *f'* may be curved at the lower end, so as to lock the lever in line beneath the pin *i'*, and back of the pin *i'* is arranged to make contact with the bottom of the socket in the end of the lever, so as to form a stop that limits the further movement of the lever when the latter has lifted the block to its desired position.

I claim as my invention—

1. In combination, in a lifting-jack, a supporting-standard, a vertically-movable lifting-block pivoted to the standard below the limit of movement of the lifting-block, and the links pivotally connected to the end of the lever and to the lifting-block, one of said links being pivotally connected near the inner end of the lifting-block and the other near the outer end thereof, all substantially as described.

2. In combination, in a lifting-jack, a supporting-standard, a lifting-block located in a slot in the standard and having a slot through which a pin passes, the supporting-pin extending through the standard and through the block, a lever pivoted to the standard below the lifting-block, and links extending between the lifting-block and the end of the lever and arranged with the pivot-pins adapted to throw past a line drawn between the other pivot of each link and the fulcrum-pin of the lever when the lifting-block is at the upper limit of its play, all substantially as described.

3. In a wagon-jack, in combination with a

standard, a vertically-movable lifting-block
having an irregular upper surface cut to differ-
ent levels, a lever pivoted to the standard be-
low the lifting-block, the links connecting the
5 lever and the lifting-block with the pivot-pins
of the links connecting them to the lever end,
arranged to be thrown past the center when
the block is at the upper limit of its play, and

the stop whereby the swinging movement of
the lever is limited, all substantially as de-
scribed.

OLIVER H. ROBERTSON.

Witnesses:

CHAS. L. BURDETT,
ARTHUR B. JENKINS.