



US00D768992S

(12) **United States Design Patent** (10) **Patent No.:** **US D768,992 S**  
**Garyga** (45) **Date of Patent:** **\*\* Oct. 18, 2016**

(54) **LUGGAGE IDENTIFICATION STRAP**  
(71) Applicant: **Margaret Garyga**, Concord, NC (US)  
(72) Inventor: **Margaret Garyga**, Concord, NC (US)  
(\*\*) Term: **14 Years**  
(21) Appl. No.: **29/523,602**  
(22) Filed: **Apr. 10, 2015**  
(51) **LOC (10) Cl.** ..... **03-01**  
(52) **U.S. Cl.**  
USPC ..... **D3/327**  
(58) **Field of Classification Search**  
USPC ..... **D3/327**  
CPC ..... **A45F 3/02; A45F 3/14**  
See application file for complete search history.

294/152  
D564,761 S \* 3/2008 McGlenn ..... D3/327  
D581,162 S \* 11/2008 Walker ..... D3/202  
D675,023 S \* 1/2013 Colgan ..... D3/327  
D704,937 S \* 5/2014 Cutler ..... D3/327

\* cited by examiner

*Primary Examiner* — Holly Baynham  
(74) *Attorney, Agent, or Firm* — Dunlap Bennett & Ludwig PLLC

(57) **CLAIM**  
The ornamental design for a luggage identification strap, as shown and described.

**DESCRIPTION**

FIG. 1 is a front perspective view of a luggage identification strap, shown in use;  
FIG. 2 is a front perspective view thereof;  
FIG. 3 is a front elevation view thereof; the rear elevation view being an identical image thereof;  
FIG. 4 is a left side elevation view thereof; the right side elevation view being an identical image thereof; and,  
FIG. 5 is a top plan view thereof; the bottom plan view being a mirror image thereof.

The broken lines shown in the drawings illustrate portions of the luggage identification strap that form no part of the claimed design.

The cutaway symbols illustrated in break lines in the drawings indicate a symbolic break in the length of the design for the luggage identification strap indicating an indeterminate length. The appearance of any portion of the article between the break lines forms no part of the claimed design.

**1 Claim, 3 Drawing Sheets**

(56) **References Cited**  
U.S. PATENT DOCUMENTS  
4,862,563 A \* 9/1989 Flynn ..... A44B 18/00  
24/306  
4,978,044 A \* 12/1990 Silver ..... A45F 3/02  
150/108  
5,333,768 A \* 8/1994 Krentz ..... A45F 3/14  
224/623  
5,460,126 A \* 10/1995 Szelewski ..... A45F 3/14  
119/859  
5,660,309 A \* 8/1997 Belanger ..... A45B 11/02  
224/250  
6,049,953 A \* 4/2000 McCay ..... A44B 18/00  
24/302  
D451,282 S \* 12/2001 Konkle ..... D3/318  
6,953,214 B2 \* 10/2005 Paz ..... A45F 3/14

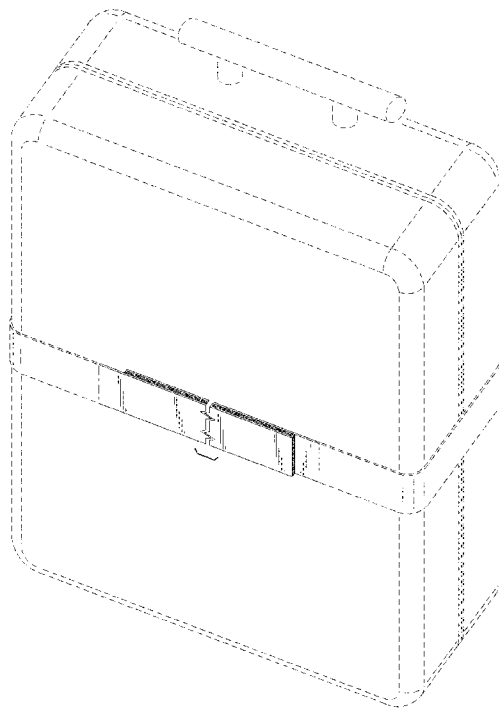

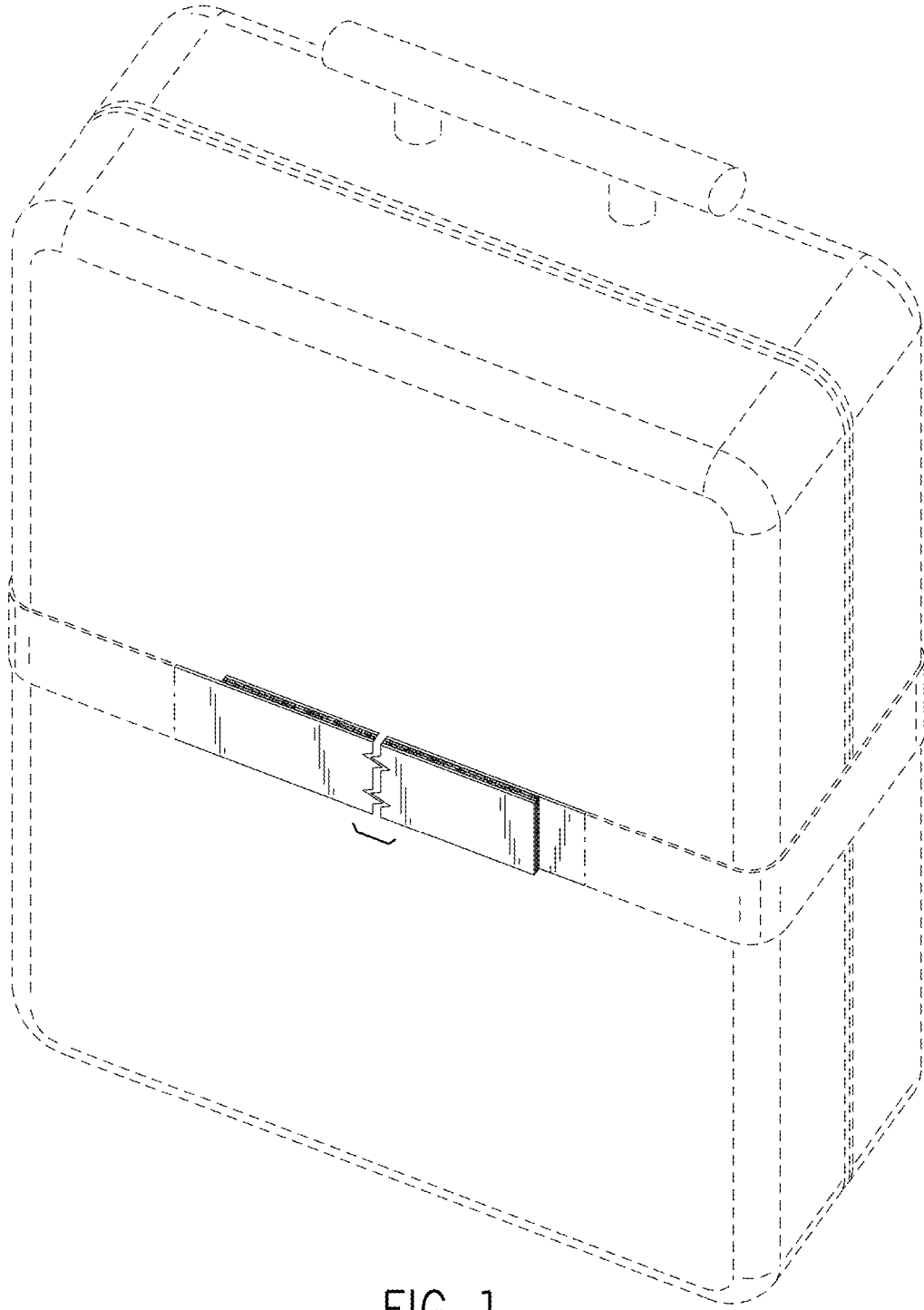

FIG. 1

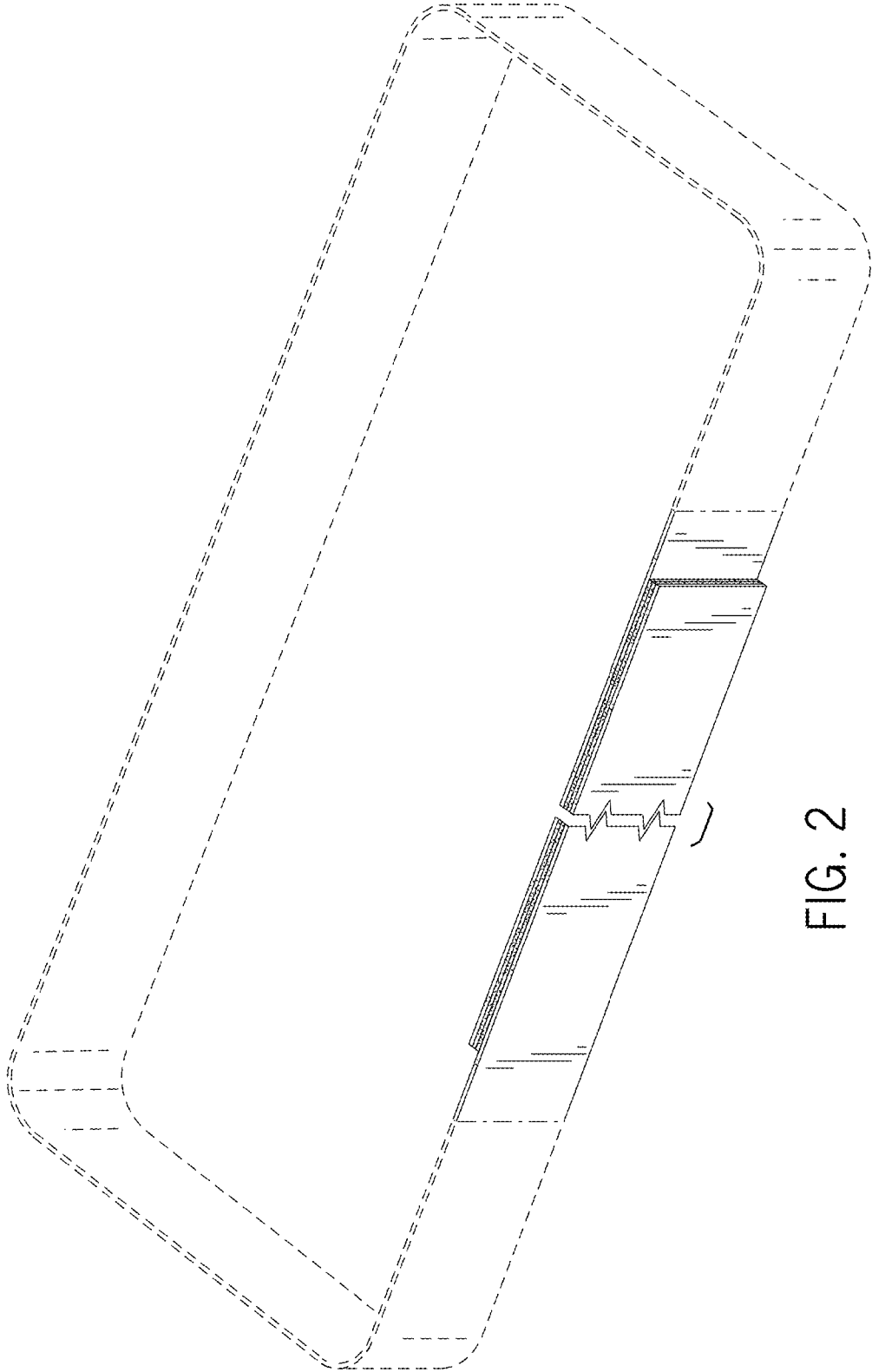

FIG. 2



FIG. 4

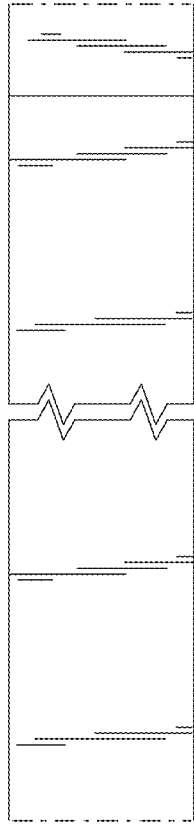

FIG. 3

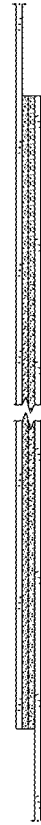

FIG. 5