

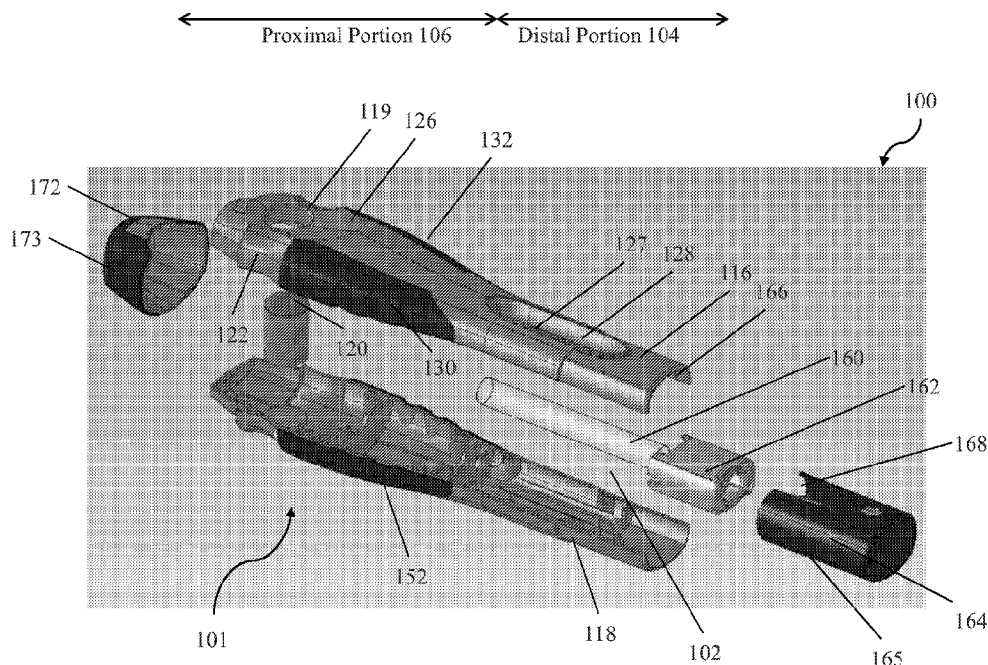

(86) Date de dépôt PCT/PCT Filing Date: 2012/01/24
 (87) Date publication PCT/PCT Publication Date: 2012/08/02
 (45) Date de délivrance/Issue Date: 2020/05/05
 (85) Entrée phase nationale/National Entry: 2013/07/18
 (86) N° demande PCT/PCT Application No.: US 2012/022433
 (87) N° publication PCT/PCT Publication No.: 2012/103141
 (30) Priorité/Priority: 2011/01/24 (US61/435,465)

(51) Cl.Int./Int.Cl. *A61M 5/31* (2006.01),
A61B 5/15 (2006.01)
 (72) Inventeurs/Inventors:
 JULIAN, JOSEPH F., US;
 LI, CHUAN, US;
 EIGER, AARON B., US;
 KURTH, MARK, US;
 KATZ, SABRINA, US;
 CALLIF, ADAM, US;
 STANGO, JAMES C., US
 (73) Propriétaire/Owner:
 ABBVIE BIOTECHNOLOGY LTD., BM
 (74) Agent: TORYS LLP

(54) Titre : DISPOSITIFS D'INJECTION AUTOMATIQUE DOTES DE SURFACES DE PREHENSION SURMOULEES
 (54) Title: AUTOMATIC INJECTION DEVICES HAVING OVERMOLDED GRIPPING SURFACES



(57) **Abrégé/Abstract:**

Exemplary embodiments provide automatic injection devices, housing components for automatic injection devices and methods for fabricating the same. An exemplary housing of an automatic injection device may be overmolded with one or more gripping surfaces to facilitate gripping and manipulation of the automatic injection device by a user when performing an injection. In an exemplary embodiment, an overmolded left gripping surface may extend along a left side of the housing and an overmolded right gripping surface may extend along a right side of the housing opposite to the left side.

(12) INTERNATIONAL APPLICATION PUBLISHED UNDER THE PATENT COOPERATION TREATY (PCT)

(19) World Intellectual Property
Organization
International Bureau(10) International Publication Number
WO 2012/103141 A1(43) International Publication Date
2 August 2012 (02.08.2012)

- (51) International Patent Classification:
A61M 5/31 (2006.01) *A61B 5/15* (2006.01)
- (21) International Application Number:
PCT/US2012/022433
- (22) International Filing Date:
24 January 2012 (24.01.2012)
- (25) Filing Language: English
- (26) Publication Language: English
- (30) Priority Data:
61/435,465 24 January 2011 (24.01.2011) US
- (71) Applicant (for all designated States except US): **ABBOTT BIOTECHNOLOGY LTD.**; Clarendon House, 2 Church Street, Hamilton, HM11 (BM).
- (72) Inventors; and
(75) Inventors/Applicants (for US only): **JULIAN, Joseph, F.** [US/US]; 629 Dawes Street, Libertyville, IL 60048 (US). **LI, Chuan** [US/US]; 555 Longfellow Avenue, Deerfield, IL 60015 (US). **EIGER, Aaron, B.** [US/US]; 3704 N. Bosworth Avenue, Chicago, IL 60613 (US). **KURTH, Mark** [US/US]; 20 W. Fairwater Avenue, Beverly Shores, IN 46301 (US). **KATZ, Sabrina** [US/US]; 4441 North Beacon Street, #1B, Chicago, IL 60640 (US). **CALIF, Adam** [US/US]; 627 W. Barry Avenue, 3d, Chicago, IL 60657 (US). **STANGO, James, C.** [US/US]; 1795 Unity Loop, Cummings, GA 30040 (US).
- (74) Agents: **BURNS, David R.** et al.; Mccarter & English, LLP, 265 Franklin Street, Boston, MA 02110 (US).
- (81) Designated States (unless otherwise indicated, for every kind of national protection available): AE, AG, AL, AM, AO, AT, AU, AZ, BA, BB, BG, BH, BR, BW, BY, BZ, CA, CH, CL, CN, CO, CR, CU, CZ, DE, DK, DM, DO, DZ, EC, EE, EG, ES, FI, GB, GD, GE, GH, GM, GT, HN, HR, HU, ID, IL, IN, IS, JP, KE, KG, KM, KN, KP, KR, KZ, LA, LC, LK, LR, LS, LT, LU, LY, MA, MD, ME, MG, MK, MN, MW, MX, MY, MZ, NA, NG, NI, NO, NZ, OM, PE, PG, PH, PL, PT, QA, RO, RS, RU, RW, SC, SD, SE, SG, SK, SL, SM, ST, SV, SY, TH, TJ, TM, TN, TR, TT, TZ, UA, UG, US, UZ, VC, VN, ZA, ZM, ZW.

[Continued on next page]

(54) Title: AUTOMATIC INJECTION DEVICES HAVING OVERMOLDED GRIPPING SURFACES

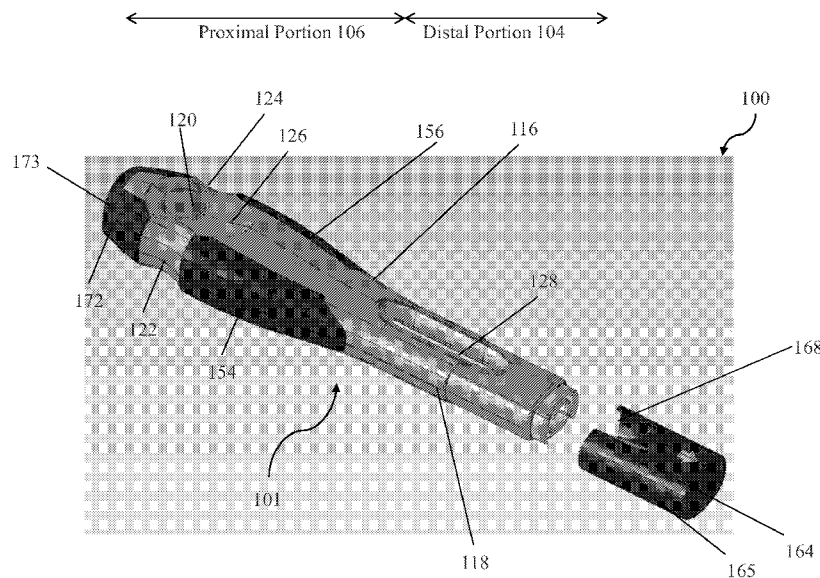

Figure 1

(57) Abstract: Exemplary embodiments provide automatic injection devices, housing components for automatic injection devices and methods for fabricating the same. An exemplary housing of an automatic injection device may be overmolded with one or more gripping surfaces to facilitate gripping and manipulation of the automatic injection device by a user when performing an injection. In an exemplary embodiment, an overmolded left gripping surface may extend along a left side of the housing and an overmolded right gripping surface may extend along a right side of the housing opposite to the left side.

WO 2012/103141 A1

WO 2012/103141 A1 

- (84) Designated States** (*unless otherwise indicated, for every kind of regional protection available*): ARIPO (BW, GH, GM, KE, LR, LS, MW, MZ, NA, RW, SD, SL, SZ, TZ, UG, ZM, ZW), Eurasian (AM, AZ, BY, KG, KZ, MD, RU, TJ, TM), European (AL, AT, BE, BG, CH, CY, CZ, DE, DK, EE, ES, FI, FR, GB, GR, HR, HU, IE, IS, IT, LT, LU, LV, MC, MK, MT, NL, NO, PL, PT, RO, RS, SE, SI, SK, SM, TR), OAPI (BF, BJ, CF, CG, CI, CM, GA, GN, GQ, GW, ML, MR, NE, SN, TD, TG).
- Published:**
- *with international search report (Art. 21(3))*
 - *before the expiration of the time limit for amending the claims and to be republished in the event of receipt of amendments (Rule 48.2(h))*

**AUTOMATIC INJECTION DEVICES HAVING
OVERMOLDED GRIPPING SURFACES**

Related Applications

This application is a non-provisional of and claims priority to U.S. Provisional
5 Patent Application No. 61/435,465, filed January 24, 2011.

Background

Automatic injection devices offer an alternative to manually-operated syringes
for administering therapeutic agents into patients' bodies and allowing patients to self-
10 administer therapeutic agents. Automatic injection devices may be used to administer
medications under emergency conditions, for example, to administer epinephrine to
counteract the effects of a severe allergic reaction. Automatic injection devices have
also been described for use in administering anti-arrhythmic medications and selective
thrombolytic agents during a heart attack. *See*, for example, U.S. Patent Nos. 3,910,260;
15 4,004,577; 4,689,042; 4,755,169; and 4,795,433.

Various types of automatic injection
devices are also described in, for example, U.S. Patent Nos. 3,941,130; 4,261,358;
5,085,642; 5,092,843; 5,102,393; 5,267,963; 6,149,626; 6,270,479; and 6,371,939; and
International Patent Publication No. WO/2008/005315.

20

Conventionally, an automatic injection device houses a syringe and, when
operated, causes the syringe to move forwardly and a needle to project from the housing
so that a therapeutic agent contained in the syringe is ejected into a patient's body.

Summary

Exemplary embodiments provide automatic injection devices, housing components for automatic injection devices and methods for fabricating the same. An exemplary housing of an automatic injection device may be overmolded with one or
5 more gripping surfaces to facilitate gripping and manipulation of the automatic injection device by a user when performing an injection. In an exemplary embodiment, an overmolded left gripping surface may extend along a left side of the housing and an overmolded right gripping surface may extend along a right side of the housing opposite to the left side.

10 In accordance with an exemplary embodiment, an automatic injection device is provided with a housing enclosing a cavity for accommodating a container. A first overmolded gripping surface is provided to extend longitudinally along a portion of the housing on a first exterior surface of the housing. A second overmolded gripping surface is provided to extend longitudinally along a portion of the housing on a second exterior
15 surface of the housing opposite to the first exterior surface.

In an exemplary embodiment, the first and second overmolded gripping surfaces on the housing are formed of a first material having a first touch perception, and non-gripping surfaces on the housing are formed of a second material having a second touch perception. In an exemplary embodiment, the first and second overmolded gripping
20 surfaces on the housing are formed of a first material having a first hardness, and non-gripping surfaces on the housing are formed of a second material having a second higher hardness.

In an exemplary embodiment, the automatic injection device includes a removable distal cap for protectively covering an injection needle couplable to the container, an exterior surface of the distal cap including an overmolded gripping surface for facilitating gripping and removal of the distal cap. In an exemplary embodiment, the automatic injection device includes a firing button protruding from an aperture in the housing and including an overmolded contact surface for facilitating actuation of the firing button by a user. In an exemplary embodiment, the automatic injection device includes a proximal terminal end for covering a proximal end of the automatic injection device, the proximal terminal end having an overmolded exterior surface. In an exemplary embodiment, a top surface of the proximal terminal end includes a recessed surface for directing and facilitating accommodation of a user's hand or finger for gripping the automatic injection device.

In accordance with another exemplary embodiment, a method is provided for assembling an automatic injection device. The method includes providing a housing enclosing a cavity for accommodating a container. The method includes overmolding, on the housing, a first gripping surface extending longitudinally along a portion of the housing on a first exterior surface of the housing. The method also includes overmolding, on the housing, a second gripping surface extending longitudinally along a portion of the housing on a second exterior surface of the housing opposite to the first exterior surface.

In an exemplary embodiment, the first and second gripping surfaces on the housing are formed of a first material having a first touch perception, and non-gripping surfaces on the housing are formed of a second material having a second touch perception. In an exemplary embodiment, the first and second gripping surfaces on the

housing are formed of a first material having a first hardness, and non-gripping surfaces on the housing are formed of a second material having a second higher hardness.

In an exemplary embodiment, the method includes overmolding a gripping surface on an exterior surface of a distal cap to facilitate gripping and removal of the distal cap, and coupling the distal cap to a distal end of the housing for protectively covering an injection needle. In an exemplary embodiment, the method includes overmolding a gripping surface on a firing button to facilitate activation of the firing button, and providing the firing button within the cavity so that part of the firing button protrudes from an aperture in the housing.

In an exemplary embodiment, the method includes overmolding a gripping surface on an exterior surface of a proximal terminal end, and coupling the proximal terminal end to a proximal end of the housing. In an exemplary embodiment, a top surface of the proximal terminal end includes a recessed surface for directing a user's hand or finger for gripping the automatic injection device.

In accordance with another exemplary embodiment, an automatic injection device is provided including a housing enclosing a cavity for accommodating a container. The housing includes a first overmolded gripping region, a second overmolded gripping region, and a recessed region abutting the first and second overmolded gripping regions.

In an exemplary embodiment, the recessed region is disposed between the first and second overmolded gripping regions. In an exemplary embodiment, a width of the housing at the recessed region is smaller than a width of the housing at the first overmolded gripping region and a width of the housing at the second overmolded

gripping region. In an exemplary embodiment, the recessed region lacks a gripping surface.

In an exemplary embodiment, the first overmolded gripping region is formed by a proximal terminal end of the housing having an exterior surface that is overmolded
5 with a gripping surface. In an exemplary embodiment, the second overmolded gripping region of the housing has a tapered tubular structure.

Brief Description of the Drawings

The foregoing and other objects, aspects, features, and advantages of exemplary embodiments will become more apparent and may be better understood by referring to
10 the following description taken in conjunction with the accompanying drawings, in which:

Figure 1 is a left side perspective view illustrating an exemplary automatic injection device in which a removable distal cap is removed and pictured separately from the housing of the device.

15 Figure 2 is a right side perspective view illustrating the exemplary automatic injection device of Figure 1.

Figure 3 is a left side exploded perspective view of the exemplary automatic injection device of Figures 1 and 2.

Figure 4 is a front view of the exemplary automatic injection device of Figures 1-
20 3.

Figure 5 is a left side view of the exemplary automatic injection device of Figures 1-3, the right side view being a mirror image of the left side view.

Figure 6A is a front close-up view of an exemplary left gripping surface provided on a first body portion of the device of Figures 1-3.

Figure 6B is a left side close-up view of the exemplary left gripping surface of Figure 6A.

5 Figure 7 is a bottom view of an exemplary removable distal cap of the exemplary automatic injection device of Figures 1-3.

Figure 8 is a top view of an exemplary proximal terminal end of the exemplary automatic injection device of Figures 1-3.

Figure 9 is a flowchart of an exemplary method for forming an exemplary
10 automatic injection device.

Detailed Description

Exemplary embodiments provide automatic injection devices having housings that are particularly designed and configured for reliable, safe, ergonomic and comfortable handling by users. Exemplary embodiments also provide housing
15 components for automatic injection devices that are particularly designed and configured for reliable, safe, ergonomic and comfortable handling by users. Exemplary embodiments also provide methods for fabricating exemplary housings for automatic injection devices and automatic injection devices including exemplary housings.

In one exemplary embodiment, one or more overmolded gripping surfaces may
20 be provided on an exterior surface of an exemplary automatic injection device housing in order to allow the device to be easily, comfortably and reliably gripped and manipulated by a user. The exemplary overmolded gripping surfaces are particularly

configured and positioned on the housing to prevent slippage from the hands of the user, and thereby to avoid injury to the user and others in the vicinity. Furthermore, the exemplary overmolded gripping surfaces are particularly configured and positioned to be ergonomic and comfortable to use, particularly by physically weak users, for
5 example, older users, users who suffer from rheumatoid arthritis, and the like.

In user tests performed using exemplary automatic injection devices, test participants appreciated exemplary overmolded gripping surfaces on the sides of the devices and the relatively large size and ergonomic shape of the device. The test participants provided high ratings for handling and grip of exemplary devices, in which
10 the overmolded gripping surfaces were the primary factor in test participants' high ratings of exemplary device configurations for handling and grip, compared to devices without overmolded gripping surfaces. For several usability factors, there was a significant positive correlation between Cochin scores and exemplary device configurations, which indicates that exemplary devices are well-suited for use by users
15 with hand dysfunction.

An exemplary automatic injections device may contain and may be used to administer a dose of a TNF α inhibitor. In an exemplary embodiment, the TNF α inhibitor may be a human TNF α antibody or antigen-binding portion thereof. In an exemplary embodiment, the human TNF α antibody or antigen-binding portion thereof
20 may be adalimumab (HUMIRA[®]) or golimumab.

I. Definitions

Certain terms are defined in this section to facilitate understanding of exemplary embodiments.

The terms “automatic injection device” and “autoinjector,” as used herein, refer to a device that enables a patient to self-administer a therapeutically effective dose of a therapeutic agent, wherein the device differs from a conventional syringe by the inclusion of a mechanism for automatically delivering the therapeutic agent to the
5 patient by injection when the mechanism is engaged.

The terms “vessel” and “container,” as used herein, refer to a syringe or cartridge that may be used in an exemplary automatic injection device for holding a dose of a therapeutic agent.

The terms “syringe” and “cartridge,” as used herein, refer to a sterile barrel
10 portion of an automatic injection device that is filled with a dose of a therapeutic agent prior to distribution or sale of the device to a patient or other non-medical professional for administration of the therapeutic agent to a patient. In an exemplary embodiment, a distal end of the barrel portion of a syringe may be coupled to a sterile hypodermic injection needle. In an exemplary embodiment, a distal end of the barrel portion of a
15 cartridge may not be coupled to an injection needle. That is, in exemplary embodiments, a syringe may be a cartridge with a pre-attached injection needle coupled to its barrel portion.

Exemplary embodiments described herein with reference to a syringe assembly may also be implemented using a cartridge assembly. Similarly, exemplary
20 embodiments described herein with reference to a cartridge assembly may also be implemented using a syringe assembly.

The term “pre-filled syringe,” as used herein, refers to a syringe that is filled with a therapeutic agent immediately prior to administration of the therapeutic agent to a

patient, and a syringe that is filled with a therapeutic agent and stored in this pre-filled form for a period of time before administration of the therapeutic agent to a patient.

The terms “injection needle” and “needle,” as used herein, refer to a needle in an automatic injection device that is inserted into a patient’s body to deliver a dose of a therapeutic agent into the patient’s body. In an exemplary embodiment, the injection needle may be directly coupled to or may otherwise be in contact with a syringe assembly or a cartridge assembly that holds a dose of the therapeutic agent. In another exemplary embodiment, the injection needle may be indirectly coupled to the syringe or cartridge assembly, for example, via a syringe needle and/or a transfer mechanism that provides fluid communication between the syringe or cartridge assembly and the injection needle.

The term “pre-injection state,” as used herein, refers to a state of an automatic injection device prior to activation of the device, i.e., prior to the start of delivery of a therapeutic agent contained in the device.

The term “injection state,” as used herein, refers to one or more states of an automatic injection device during the delivery of a therapeutic agent contained in the device.

The term “post-injection state,” as used herein, refers to completion of delivery of a therapeutically effective dose of a therapeutic agent contained in the device, or removal of the device from the patient prior to completion of delivery of a therapeutically effective dose of the therapeutic agent.

An automatic injection device provided in accordance with exemplary embodiments may include a “therapeutically effective amount” or a “prophylactically effective amount” of an antibody or antibody portion of the invention. A

“therapeutically effective amount,” as used herein, refers to an amount effective, at dosages and for periods of time necessary, to achieve the desired therapeutic result. A therapeutically effective amount of the antibody, antibody portion, or other TNF α inhibitor may vary according to factors such as the disease state, age, sex, and weight of the patient, and the ability of the antibody, antibody portion, or other TNF α inhibitor to elicit a desired response in the patient. A therapeutically effective amount is also one in which any toxic or detrimental effects of the antibody, antibody portion, or other TNF α inhibitor are outweighed by the therapeutically beneficial effects. A “prophylactically effective amount,” as used herein, refers to an amount effective, at dosages and for periods of time necessary, to achieve the desired prophylactic result. Typically, since a prophylactic dose is used in patients prior to or at an earlier stage of disease, the prophylactically effective amount will be less than the therapeutically effective amount.

The terms “substance” and “therapeutic agent,” as used herein, refer to any type of drug, biologically active agent, biological substance, chemical substance or biochemical substance that is capable of being administered in a therapeutically effective amount to a patient employing exemplary automatic injection devices. Exemplary therapeutic agents usable in exemplary automatic injection devices may include, but are not limited to, agents in a liquid state. Such agents may include, but are not limited to, adalimumab (HUMIRA®) and proteins that are in a liquid solution, e.g., fusion proteins and enzymes. Examples of proteins in solution include, but are not limited to, Pulmozyme (Dornase alfa), Regranex (Becaplermin), Activase (Alteplase), Aldurazyme (Laronidase), Amevive (Alefacept), Aranesp (Darbepoetin alfa), Becaplermin Concentrate, Betaseron (Interferon beta-1b), BOTOX (Botulinum Toxin Type A), Elitek (Rasburicase), Elspar (Asparaginase), Epogen (Epoetin alfa), Enbrel (Etanercept), Fabrazyme (Agalsidase beta), Infergen (Interferon alfacon-1), Intron A (Interferon alfa-

2a), Kineret (Anakinra), MYOBLOC (Botulinum Toxin Type B), Neulasta (Pegfilgrastim), Neumega (Oprelvekin), Neupogen (Filgrastim), Ontak (Denileukin diftitox), PEGASYS (Peginterferon alfa-2a), Proleukin (Aldesleukin), Pulmozyme (Dornase alfa), Rebif (Interferon beta-1a), Regranex (Becaplermin), Retavase (Reteplase), Roferon-A (Interferon alfa-2), TNKase (Tenecteplase), and Xigris (Drotrecogin alfa), Arcalyst (Rilonacept), NPlate (Romiplostim), Mircera (methoxypolyethylene glycol-epoetin beta), Cinryze (C1 esterase inhibitor), Elaprase (idursulfase), Myozyme (alglucosidase alfa), Orenicia (abatacept), Naglazyme (galsulfase), Kepivance (palifermin) and Actimmune (interferon gamma-1b).

10 The term “dose” or “dosage,” as used herein, refers to an amount of a therapeutic agent, such as a TNF α inhibitor, which is administered to a patient preferably using the wearable automatic injection device of the invention. In one embodiment, the dose comprises an effective amount, for example, including, but not limited to, 20 mg, 30 mg, 40 mg, 50 mg, 60 mg, 70 mg, 80 mg, 90 mg, 100 mg, 110 mg, 120 mg, 130 mg, 140 mg, 150 mg, and 160 mg, of the TNF α inhibitor adalimumab.

 The term “dosing,” as used herein, refers to the administration of a therapeutic agent (e.g., an anti-TNF α antibody) to achieve a therapeutic objective (e.g., treatment of rheumatoid arthritis).

20 The term “dosing regimen,” as used herein, refers to a treatment schedule for a therapeutic agent, such as a TNF α inhibitor, e.g., a treatment schedule over a prolonged period of time and/or throughout the course of treatment, e.g. administering a first dose of a TNF α inhibitor at week 0 followed by a second dose of a TNF α inhibitor on a biweekly dosing regimen.

The term “treatment,” as used herein, refers to therapeutic treatment, as well as prophylactic or suppressive measures, for the treatment of a disorder, such as a disorder in which TNF α is detrimental, e.g., rheumatoid arthritis.

5 The term “patient” or “user,” as used herein, refers to any type of animal, human or non-human, that may be administered a therapeutic agent using exemplary automatic injection devices.

The term “proximal” refers to a portion or end or component of an exemplary automatic injection device that is farthest from an injection site on a patient’s body when the device is held against the patient for an injection or for mimicking an injection.

10 The term “distal” refers to a portion or end or component of an exemplary automatic injection device that is closest to an injection site on a patient’s body when the device is held against the patient for an injection or for mimicking an injection.

The term “planar” is used herein, in a broad lay sense, to mean exactly planar or approximately planar within some tolerance from the exactly planar.

15 The term “concave” is used herein, in a broad lay sense, to mean exactly concave or approximately concave within some tolerance from the exactly concave.

The term “convex” is used herein, in a broad lay sense, to mean exactly convex or approximately convex within some tolerance from the exactly convex.

20 The term “elliptical” is used herein, in a broad lay sense, to mean exactly elliptical or approximately elliptical within some tolerance from the exactly elliptical.

The term “oval” is used herein, in a broad lay sense, to mean exactly oval or approximately oval within some tolerance from the exactly oval.

The term “rectangular” is used herein, in a broad lay sense, to mean exactly rectangular or approximately rectangular within some tolerance from the exactly rectangular.

The term “parallel” is used herein, in a broad lay sense, to mean exactly parallel
5 or approximately parallel within some tolerance from the exactly parallel.

The term “straight” is used herein, in a broad lay sense, to mean exactly straight or approximately straight within some tolerance from the exactly straight.

The term “equal” is used herein, in a broad lay sense, to mean exactly equal or approximately equal within some tolerance.

10 The term “adjacent” is used herein, in a broad lay sense, to mean immediately adjacent or approximately adjacent within some tolerance.

The term “abut” is used herein, in a broad lay sense, to mean immediately abutting or approximately abutting within some tolerance.

The term “transverse axis” is used herein to refer to an axis that is substantially
15 perpendicular to a longitudinal axis.

II. Exemplary Embodiments

Exemplary embodiments are described below with reference to certain illustrative embodiments. While exemplary embodiments are described with respect to using an automatic injection device to provide an injection of a dose of a therapeutic
20 agent, one of ordinary skill in the art will recognize that exemplary embodiments are not limited to the illustrative embodiments and that exemplary automatic injection devices may be used to inject any suitable therapeutic agent into a patient. In addition,

components of exemplary automatic injection devices and methods of making and using exemplary automatic injection devices are not limited to the illustrative embodiments described below.

Figures 1-8 illustrate an exemplary automatic injection device 100 having one or
5 more overmolded gripping surfaces for facilitating gripping and manipulation of the device. The figures indicate a longitudinal axis L that runs substantially along the length of the device 100, a first transverse axis H that runs substantially perpendicular to the longitudinal axis L of the device, and a second transverse axis V that runs substantially perpendicular to both longitudinal axis L and first transverse axis H.

10 In some exemplary embodiments, an exemplary length of the device 100 may be about 4, 4.5, 4.8, 5, 5.5, 6, 6.5, 6.6, 6.7, 6.8, 6.9, 7, 7.5, 8, 8.5, 9, 9.5, 10 inches, but is not limited to these exemplary lengths. In some exemplary embodiments, an exemplary width of the device 100 (at its widest location) may be about 0.5, 0.6, 0.7, 0.8, 0.9, 1.0, 1.1, 1.2, 1.3, 1.4, 1.5, 1.6, 1.7, 1.8, 1.9, 2, 2.1, 2.2, 2.3, 2.4, 2.5, 2.6, 2.7, 2.8, 2.9, 3.0
15 inches, but is not limited to these exemplary widths. In some exemplary embodiments, an exemplary thickness of the device 100 (at its thickest location) may be about 0.1, 0.2, 0.3, 0.4, 0.5, 0.6, 0.7, 0.8, 0.9, 1.0, 1.1, 1.11, 1.12, 1.13, 1.14, 1.15, 1.16, 1.17, 1.18, 1.19, 1.2, 1.3, 1.4, 1.5, 1.6, 1.7, 1.8, 1.9, 2, 2.1, 2.2, 2.3, 2.4, 2.5, 2.6, 2.7, 2.8, 2.9, 3.0 inches, but is not limited to these exemplary thicknesses. In an exemplary embodiment,
20 the device 100 may have an exemplary length of about 6.69 inches, an exemplary width of about 1.46 inches at the widest portion, and an exemplary thickness of about 1.15 inches at the thickest portion. In another exemplary embodiment, the device 100 may have an exemplary length of about 4.8 inches, an exemplary width of about 0.8 inches at the widest portion, and an exemplary thickness of about 0.6 inches at the thickest

portion. The exemplary dimensions of the recited exemplary devices allow the device to be conformably and ergonomically held in the grip of a user's hand. This allows a user to reliably and comfortably grip and manipulate the device in order to perform an injection.

5 Exemplary automatic injection device 100 may include an outer housing 101 for housing a container, such as a syringe or cartridge. The container may be pre-filled with a dose of a therapeutic agent to be injected into a patient's body. The housing 101 of the device, in its assembled form, may have any suitable size and shape for storing and dispensing the dose of the therapeutic agent. The assembled housing 101 may have a

10 shape that is designed and configured to be conformable to a user's hand and so that the user can comfortably and reliably hold the device 100 during an injection. In an exemplary embodiment, the assembled housing 101 may have an elongated structure so that its length taken along the longitudinal axis L is much greater than its width taken along the first transverse axis H and its thickness taken along a second transverse axis V .

15 An exemplary ratio of the length to the width (at the widest location) of the device may be, but is not limited to, 2:1, 3:1, 4:1, 5:1, 6:1, 7:1, 8:1, 9:1, 10:1, all intermediate ratios, and the like. An exemplary ratio of the length to the thickness (at the thickest location) of the device may be, but is not limited to, 2:1, 3:1, 4:1, 5:1, 6:1, 7:1, 8:1, 9:1, 10:1, all intermediate ratios, and the like.

20 Figure 1 is a left side perspective view illustrating an exemplary automatic injection device 100 having an outer housing 101. Figure 2 is a right side perspective view of the exemplary automatic injection device 100 of Figure 1. In an exemplary embodiment, the housing 101 of the device 100 may have a tapered tubular structure with a substantially elliptical or oval cross-section. In the tapered tubular structure, the

width of the housing 101 may be larger at a proximal portion 106 of the housing 101 than at a distal portion 104 of the housing 101. The tapered tubular shape of the exemplary housing allows the device to be streamlined and to be conformably and ergonomically held in and manipulated by a user's hand.

5 The housing 101 of the device 100 may be formed of a plurality of body components that are assembled together. In an exemplary embodiment, the housing 101 may be formed from a first body portion 116 and a second body portion 118 that, when cooperatively engaged to each other along their peripheral edges, enclose and provide a cavity therebetween. The first and second body portions may be cooperatively engaged
10 to each other using any suitable technique including, but not limited to, bonding, gluing, ultrasonic welding, friction fit, snap fit, interference fit, screws, attachment between corresponding protrusions and recesses, and the like. One of ordinary skill in the art will recognize that, in other exemplary embodiments, the cavity of the device may be enclosed in a single body component or in three or more body components when
15 assembled together.

A firing button 120 may extend from a surface of the first body portion 116. The firing button 120, when activated by a user, may cause an injection to be performed by the device 100. In an exemplary embodiment, a recessed or concave portion 126 may be provided on the first body portion 116 abutting the firing button 120 to facilitate
20 activation of the firing button 120. The recessed portion 126 may surround the firing button 120 in an exemplary embodiment to accommodate a user's finger as the user presses on the firing button 120.

A transparent inspection window 128 may be provided in a surface of the first body portion 116 to allow a user to view the contents of the device 100. The transparent

inspection window 128 may allow the user to view a therapeutic agent contained in the device 100, for example, to ensure clarity of the agent, and to view an end-of-injection indicator that materializes at the end of a successful injection. An exemplary inspection window 128 may be substantially elongated in shape, for example, an elongated
5 rectangle (with sharp or rounded edges), an elongated elliptical shape, and the like, although other shapes are possible. In the elongated inspection window 128, the length extending along the longitudinal axis L may be substantially greater than the width extending along the first transverse axis H. In exemplary embodiments, a ratio between the length and the width of the inspection window may include, but is not limited to,
10 1.5:1, 2.0:1, 2.5:1, 3.0:1, 3.5:1, 4.0:1, 4.5:1, 5:1, all intermediate ratios, and the like.

A proximal terminal end 172 of the device housing may be provided to cover the proximal end of the device 100. In an exemplary embodiment, the proximal terminal end 172 may be coupled to the proximal end of the assembled first and second body portions. The proximal terminal end 172 may take any suitable size and shape. In an
15 exemplary embodiment, the proximal terminal end 172 may have a substantially tubular configuration with a substantially oval or elliptical shape. In an exemplary embodiment, at least part of the exterior surface of the proximal terminal end 172 may be overmolded with one or more gripping surfaces 173 to facilitate gripping of the proximal portion of the device. In an exemplary embodiment, the entire exterior surface of the proximal
20 terminal end 172 may be covered by an overmolded gripping surface 173. Corresponding recesses may be provided on the exterior surface of the proximal terminal end 172 to accommodate the gripping surfaces.

A removable distal cap 164 may be coupled to the distal end of the assembled first and second body portions to cover the distal end of the device 100 in order to

prevent exposure of the injection needle prior to an injection. The distal cap 164 protects against accidental and/or unwanted contact of a user with the injection needle. The distal cap 164 also protects against damage to and contamination of the injection needle when the device is not in use. The distal cap 164 may take any suitable size and shape. In an exemplary embodiment, the distal cap 164 may have a substantially tubular configuration with a substantially oval or elliptical shape. In an exemplary embodiment, a front surface of the distal cap 164 may have a concave cutout portion 168 for accommodating part of the inspection window 128.

In an exemplary embodiment, the exterior surface of the distal cap 164 may lack overmolded gripping surfaces. In other exemplary embodiments, the exterior surface of the distal cap 164 may be overmolded with one or more gripping surfaces 165 for facilitating gripping and removal of the distal cap 164 from the device. In an exemplary embodiment, the entire exterior surface of the distal cap 164 may be covered by an overmolded gripping surface 165. Corresponding recesses may be provided on the exterior surface of the distal cap 164 to accommodate the gripping surfaces.

In an exemplary embodiment, one or more ridges (that protrude from the exterior surface) and/or one or more grooves or divots (that are depressed into the exterior surface) may be provided at the gripping surfaces 165 on the distal cap 164 to further facilitate gripping and manipulation of the device. The shapes and locations of the ridges and/or grooves may be altered as desired, and any desired number of ridges and/or grooves may be provided. In an exemplary embodiment, the ridges and/or grooves may extend substantially perpendicularly to the longitudinal axis L of the device. In an exemplary embodiment, the gripping surfaces 165 may include textured surfaces to improve the tactile feel and further facilitate firm gripping of the device. In

an exemplary embodiment, the distal cap 164 may include one or more protrusions 170a, 170b (shown in Figure 5) that extend outwardly from the front surface and the back surface of the distal cap 164 to further facilitate gripping of the cap 164.

In an exemplary embodiment, the distal cap 164 may frictionally engage a
5 recessed or stepped portion of the housing in order to be retained in position on the housing when the device is not in use. In an exemplary embodiment, the distal cap 164 may include a boss for locking and/or joining the cap to the housing until the user is ready to perform an injection. Any suitable mating mechanism may be used in accordance with the teachings of exemplary embodiments.

10 When the proximal terminal end 172, the first body portion 116 and the second body portion 118 are assembled together, they form a tapered tubular structure. Side surfaces of the body portions 116, 118 abutting the gripping surfaces 173 on the proximal terminal end 172 may include one or more recessed or concave portions 122, 124. In an exemplary embodiment, two recessed portions 122, 124 may be provided at
15 opposite sides of the device abutting the firing button 120. The recessed portions allow the hand of the user to be accommodated in a comfortable position when pressing the firing button 120.

A portion of the body portions 116, 118 abutting the recessed portions 122, 124 may be overmolded with one or more gripping surfaces 154, 156 to facilitate holding
20 and manipulation of the device. In an exemplary embodiment, two gripping surfaces 154, 156 may be provided at opposite side surfaces of the device. A first gripping surface 154 may abut a first recessed portion 122, and a second gripping surfaces 156 may abut a second recessed portion 124. Corresponding recesses may be provided on the exterior surface of the first body portion 116 to accommodate the gripping surfaces.

In an exemplary housing for an automatic injection device, a first overmolded gripping region, a second overmolded gripping region and a recessed region abutting the first and second overmolded gripping regions may be provided. The first overmolded gripping region, the second overmolded gripping region and the recessed region may cooperatively provide an ergonomic and comfortable gripping area at which a user may grip the automatic injection device in order to perform an injection.

In this exemplary embodiment, the first overmolded gripping region may be formed by the proximal terminal end 172 having an overmolded outer surface or covering. The second overmolded gripping region may be formed part of the assembly of the first body portion 116 and the second body portion 118 having one or more overmolded gripping surfaces (for example, gripping surfaces 154, 156). In an exemplary embodiment, the second overmolded gripping region may have a substantially tapered tubular structure for providing an ergonomic fit with a user's hand. The recessed region abutting the first and second overmolded gripping regions may be formed by a portion of the assembly of the first body portion 116 and the second body portion 118 that is narrower in width than the first overmolded gripping region and the second overmolded gripping region. In an exemplary embodiment, the recessed region may be provided between the first and second overmolded gripping regions. In an exemplary embodiment, the recessed region may lack any overmolded gripping surfaces.

Figure 3 illustrates an exploded view of the exemplary automatic injection device 100 of Figures 1 and 2. In an exemplary embodiment, the first body portion 116 may include a substantially planar front surface (extending substantially along the L-H plane) and left and right side surfaces (extending substantially along the L-V plane). The front

surface of the first body portion 116 may contiguously and integrally transition to left and right side surfaces of the first body portion 116. The edges at which the front surface transitions to the side surfaces may be sharp, or smooth and rounded in order to maintain a streamlined shape of the device and for ergonomic handling of the device.

5 The front and/or side surfaces of the first body portion 116 may be substantially flat or slightly convex so that the assembled housing ergonomically fits within a user's hand. The front surface may be wider at the proximal portion 106 of the device than at the distal portion 104. One of ordinary skill in the art will recognize that other exemplary shapes are possible for the first body portion 116 of the device.

10 In an exemplary embodiment, the second body portion 118 may include a substantially planar front surface (extending substantially along the L-H plane) and left and right side surfaces (extending substantially along the L-V plane). The front surface of the second body portion 118 may contiguously and integrally transition to left and right side surfaces of the second body portion 118. The edges at which the front surface transitions to the side surfaces may be sharp, or smooth and rounded in order to maintain a streamlined shape of the device and for ergonomic handling of the device. The front and/or side surfaces of the second body portion 118 may be substantially flat or slightly convex so that the assembled housing ergonomically fits within a user's hand. The front surface may be wider at the proximal portion 106 of the device than at the distal portion 15 104. One of ordinary skill in the art will recognize that other exemplary shapes are possible for the second body portion 118 of the device.

As illustrated in Figure 3, the first body portion 116 and the second body portion 118 may be cooperatively engaged to each other along their peripheral edges to enclose and provide a cavity 102 therebetween. The upper and second body portions may be

cooperatively engaged to each other using any suitable technique including, but not limited to, bonding, gluing, ultrasonic welding, friction fit, snap fit, interference fit, screws, attachment between corresponding protrusions and recesses, and the like. One of ordinary skill in the art will recognize that, in other exemplary embodiments, the cavity 102 of the device may be enclosed in a single body component or in three or more body components when assembled together.

An exemplary container 160 is preferably slidably positioned in the cavity 102 and is coupled to an injection needle (not shown) at a distal end. The injection needle may be covered by a needle shield 162, for example, a soft needle shield and/or a rigid needle shield. A container advancement mechanism may be provided within the housing to mechanically advance the container 160 within and relative to the housing and to eject the therapeutic agent from the container 160 for performing an injection. The container advancement mechanism may include one or more actuators (e.g., one or more biasing members) that move the container from a sheathed position to a projecting position. When the device is in a pre-injection state, the container 160 may be in a sheathed position, i.e., retracted within the housing. When the device is actuated, the container advancement mechanism may advance the container 160 to a projecting position so that the injection needle projects from a distal end of the housing to allow ejection of the therapeutic agent into a patient's body. The distal end of the housing may include an aperture through which the needle may project.

The cavity 102 within the housing may also accommodate a firing engagement mechanism, for example, the firing button 120. The firing button 120, when actuated by depressing, activates the container advancement mechanism that, in turn, advances the container 160 toward the injection site, drives the injection needle into the injection site

and delivers the therapeutic agent into the injection site. In an exemplary embodiment, at least a portion of the exterior surface of the firing button 120 may be overmolded with one or more rubberized gripping surfaces to facilitate pressing of the firing button by a user's finger or hand. In an exemplary embodiment, the entire exterior surface of the firing button may be covered by an overmolded gripping surface. In an exemplary
5 embodiment, the gripping surfaces on the firing button 120 may be colored differently from the non-gripping surfaces to provide a visual affordance to indicate which area of the device should be gripped. For example, the one or more gripping surfaces on the firing button 120 may be green, while all other surfaces on the device may be one or
10 more colors that are not green.

Figure 3 shows that a front surface of the first body portion 116 may include a first aperture 119 through which the firing button 120 may protrude outside the front surface. An exemplary aperture 119 may be circular to accommodate the firing button 120 with a circular cross-section, although other shapes are possible. The front surface
15 of the first body portion 116 may include a second aperture 127 for accommodating the transparent inspection window 128.

As illustrated in Figure 3, in an exemplary embodiment, the removable distal cap 164 may frictionally engage a recessed or stepped portion 166 of the housing in order to be retained in position on the housing when the device is not in use.

20 Figure 4 illustrates a front surface of the first body portion 116 of the exemplary automatic injection device 100. Figure 5 illustrates a left side view of the first body portion 116 and the second body portion 118 as assembled in the device 100.

As illustrated in Figure 4, an exemplary automatic injection device 100 may have a tapered tubular shape with a substantially elongated, elliptical cross-section. The proximal terminal end 172 of the device may have a narrower proximal end (width w1) that broadens slightly and gradually to a larger width (width w2) at the distal end of the proximal terminal end 172. The proximal end of the first body portion 116 abutting the proximal terminal end 172 may include one or more recessed portions 122, 124 at the sides. The recessed portions 122, 124 may create a narrow necked portion (width w3) that is narrower than the adjacent width (width w2) of the proximal terminal end 172. At the distal end of the recessed portions 122, 124, the first body portion 116 may widen to the largest width of the device (width W) and may gradually taper to a narrower width (width w4) near the mid-portion of the device. At the distal portion 104 of the device, the first body portion 116 may have a substantially uniform narrow width (width w4). The second body portion 118 may have a substantially similar shape and configuration as the first body portion 116. As illustrated in Figure 5, in an exemplary embodiment, the removable distal cap 164 may include one or more protrusions 170a, 170b (shown in Figure 5) that extend outwardly from the front surface and the back surface of the distal cap 164 to further facilitate gripping of the distal cap.

One of ordinary skill in the art will recognize that other shapes are possible in exemplary automatic injection device 100.

As illustrated in Figures 4 and 5, in an exemplary embodiment, a left gripping surface 130 may be provided to partly cover and extend across the left side surface of the first body portion 116, and a right gripping surface 132 may be provided to partly cover and extend across the right side surface of the first body portion 116. In an exemplary embodiment, each gripping surface 130, 132 may be disposed between the

firing button 120 and the inspection window 128. One of ordinary skill will recognize that other placements of the gripping surfaces 130, 132 are possible. Similarly, in an exemplary embodiment, a left gripping surface 152 may be provided to partly cover and extend across the left side surface of the second body portion 118, and a right gripping surface 153 may be provided to partly cover and extend across the right side surface of the second body portion 118. When the first and second body portions are assembled, the left gripping surfaces 130, 152 may form a contiguous left gripping surface 154 on the housing, and the right gripping surfaces 132, 153 may form a contiguous right gripping surface 156 on the housing. The left and right contiguous gripping surfaces 154, 156 facilitate reliable and comfortable gripping and manipulation of the device by a user's hand, which markedly and surprisingly improves the user experience of physically weak users, for example, older users and users suffering from rheumatoid arthritis.

In user tests performed using exemplary automatic injection devices, test participants liked the overmolded gripping surfaces on the sides of the device, the ridges on the overmolded gripping surfaces, and the relatively large size and ergonomic shape of the device. Most test participants (58%) strongly preferred the handling and grip of an example automatic injection device of the present invention. Overall, the example device configuration received a high average rating of 8.1 out of 10.0. The overmolded gripping surfaces were the primary factor in the participants' high ratings of the example device for handling and grip. For several usability factors, there was a significant positive correlation between Cochin scores and the example device of the present invention with the overmolded gripping surfaces, which indicates that the example device of the present invention is well-suited for those with hand dysfunction.

One of ordinary skill in the art will recognize that the left and right gripping surfaces may have different sizes, shapes and configurations than the exemplary sizes, shapes and configurations shown in Figures 1-8. One of ordinary skill in the art will recognize that more or fewer gripping surfaces may be provided on exemplary automatic injection devices that the exemplary left and right gripping surfaces shown in Figures 1-8. One of ordinary skill in the art will also recognize that one or more gripping surfaces may be positioned on exemplary automatic injection devices in positions other than the exemplary positions shown in Figures 1-8. Further, one of ordinary skill in the art will recognize that the outline of each gripping surface may have a smooth, rounded, streamlined configuration in some exemplary embodiments.

The overmolded gripping surfaces provided in exemplary embodiments may be formed of any suitable material that provides a first soft and high-friction touch perception to a user, as compared to the portions of the device that lack an overmolded gripping surface which provide a second hard and low-friction touch perception to a user. The difference in the sensory perceptions provides a touch affordance to a user, indicating that the device is to be gripped at regions provided with the overmolded gripping surfaces.

In an exemplary embodiment, the overmolded gripping surfaces may be formed of a first type of material having a soft, high-friction touch perception to a user, while the portions of the device lacking overmolded gripping surfaces may be formed of a second type of material having a harder, lower-friction touch perception to a user. In an exemplary embodiment, the overmolded gripping surfaces may be formed of a first material with a lower hardness, while the non-gripping surfaces may be formed of a second material with a higher hardness.

For example, the non-gripping surfaces may be formed of any rigid thermoplastic material or rigid substrate suitable for use in a medical device application and suitable for providing a hard, low-friction touch perception to the user. Rigid thermoplastics can include materials such as polypropylene (PP), polyethylene (PE),
5 polystyrene (PS), high impact polystyrene (HIPS), polycarbonate (PC), acrylonitrile-butadiene-styrene (ABS), poly(ethylene terephthalate) (PET), polyamide (PA), PC/ABS blend and PPO/PS blends.

Exemplary overmolded gripping surfaces may be formed of materials having any suitable material grade and hardness for providing a soft, high-friction touch perception
10 to the user. Exemplary overmolded gripping surface materials may include, but are not limited to, rubber (for example, having a durometer of 50A in one embodiment), thermoplastic elastomers (TPEs), thermoplastic vulcanizate (TPV), and the like. Exemplary thermoplastic elastomers that may be used to form exemplary overmolded gripping surfaces include, but are not limited to, TPEs from KRAIBURG, the
15 Dynaflex™ TPE from PolyOne, the Versaflex™ TPE from PolyOne, the Versollan™ TPE from PolyOne, the OnFlex™ TPE from Polyone, and the like. Exemplary thermoplastic vulcanizates that may be used to form exemplary overmolded gripping surfaces include, but are not limited to, the Santoprene™ thermoplastic from ExxonMobil and the like.

20 In an exemplary embodiment, the overmolded gripping surfaces may be colored differently from the non-gripping surfaces to provide a visual affordance to indicate which area of the device should be gripped. For example, the left and right overmolded gripping surfaces may be maroon in color while the non-gripping surfaces on the housing may be grey in color.

As illustrated in Figure 5, in an exemplary embodiment, one or more ridges (that protrude from the exterior surface) and/or one or more grooves or divots (that are depressed into the exterior surface) 158a, 158b, 158c (as illustrated in Figures 5 and 6B) may be provided at the left overmolded gripping surface 154 and/or the right

5 overmolded gripping surface 156 to further facilitate gripping and manipulation of the device. The shapes and locations of the ridges and/or grooves may be altered as desired, and any desired number of ridges and/or grooves may be provided. In an exemplary embodiment, the ridges and/or grooves may extend substantially perpendicularly to the longitudinal axis L of the device. In an exemplary embodiment, the overmolded

10 gripping surfaces may include textured surfaces to improve the tactile feel and further facilitate firm gripping of the device.

Figure 6A is a front close-up view of an exemplary left overmolded gripping surface 130 provided on a first body portion 116 of the device 100 of Figure 1. Figure 6B is a left side close-up view of the exemplary left overmolded gripping surface 130 of

15 Figure 6A. The right overmolded gripping surface 132 of the first body portion 116, the left overmolded gripping surface 152 of the second body portion 118, and the right overmolded gripping surface 153 of the second body portion 118 may be similar in structure and configuration.

Referring to Figures 6A and 6B, the left overmolded gripping surface 130 may

20 have a first longitudinal side 134 that extends on the front surface of the first body portion 116 substantially along the longitudinal axis L. In an exemplary embodiment, the first longitudinal side 134 of the left overmolded gripping surface 130 may be substantially linear, while in another exemplary embodiment, the first longitudinal side 134 may be slightly concave or convex. A proximal end 136 of the first longitudinal

side 134 may extend toward and connect with an end 138 of a first horizontal side 140 of the left overmolded gripping surface 130. The first horizontal side 140 may extend across the left side surface of the first body portion 116 substantially along the second transverse axis V, ending at the peripheral edge of the first body portion 116.

5 In an exemplary embodiment, a connecting side 142 extending between ends 136, 138 may connect the first longitudinal side 134 to the first horizontal side 140. In an exemplary embodiment, the first horizontal side 140 may include a beveled edge extending to the first longitudinal side 134 at an angle to both longitudinal axis L and the first transverse axis H.

10 In an exemplary embodiment, the first longitudinal side 134 of the left overmolded gripping surface 130 may be substantially longer than the first horizontal side 140. An exemplary ratio of the length of the first longitudinal side 134 to the length of the first horizontal side 140 may include, but is not limited to, about 2:1, 2.5:1, 3:1, 3.5:1, 4:1, 4.5:1, 5:1, all intermediate ratios, and the like.

15 A distal end 144 of the first longitudinal side 134 may extend toward and connect with an end 146 of a second horizontal side 148 of the left overmolded gripping surface 130. In an exemplary embodiment, a connecting side 150 extending between the ends 144, 146 may connect the first longitudinal side 134 to the second horizontal side 148. In an exemplary embodiment, the connecting side 150 may have a length greater
20 than that of the connecting side 142. In exemplary embodiments, a ratio of the length of the connecting side 150 to the length of the connecting side 142 may include, but is not limited to, 1.5:1, 1.75:1, 2:1, 2.25:1, 2.5:1, 2.75:1, 3:1, 3.25:1, 3.5:1, 3.75:1, 4:1, all intermediate ratios, and the like, but is not limited to these exemplary ratios. The second horizontal side 148 may extend across the left side surface of the first body portion 116

substantially along the second transverse axis V, ending at the peripheral edge of the first body portion 116.

In an exemplary embodiment, the first longitudinal side 134 may be substantially longer than either the first horizontal side 140 or the second horizontal side 148. An
5 exemplary ratio of the length of the first longitudinal side 134 to the length of either horizontal side may include, but is not limited to, about 2:1, 2.5:1, 3:1, 3.5:1, 4:1, 4.5:1, 5:1, 5.5:1, 6:1, 6.5:1, 7:1, all intermediate ratios, and the like.

Figure 7 is a bottom view of an exemplary removable distal cap 164 showing the overmolded gripping surface 165. The overmolded gripping surfaces 165 may be
10 formed of any suitable material that provides first a soft and high-friction touch perception to a user, as compared to the portions of the device that lack an overmolded gripping surface which provide a hard and low-friction touch perception to a user. The difference in the sensory perceptions provides a touch affordance to a user, indicating that the device is to be gripped at regions provided with the overmolded gripping
15 surfaces.

In an exemplary embodiment, the overmolded gripping surfaces may be formed of a first type of material having a soft, high-friction touch perception, while the non-gripping surfaces are formed of a second type of material having a harder, lower-friction touch perception. Exemplary overmolded gripping surfaces 165 may be formed of
20 materials having any suitable material grade and hardness for providing a soft, high-friction touch perception to the user. Exemplary overmolded gripping surface materials may include, but are not limited to, rubber (for example, having a durometer of 50A in one embodiment), thermoplastic elastomers (TPEs), thermoplastic vulcanizate (TPV), and the like. Exemplary thermoplastic elastomers that may be used to form exemplary

overmolded gripping surfaces include, but are not limited to, TPEs from KRAIBURG, the Dynaflex™ TPE from PolyOne, the Versaflex™ TPE from PolyOne, the Versollan™ TPE from PolyOne, the OnFlex™ TPE from Polyone, and the like. Exemplary thermoplastic vulcanizates that may be used to form exemplary overmolded gripping surfaces include, but are not limited to, the Santoprene™ thermoplastic from ExxonMobil and the like. In an exemplary embodiment, the overmolded gripping surfaces 165 may be colored differently from the non-gripping surfaces to provide a visual affordance to indicate which area of the device should be gripped. For example, the one or more overmolded gripping surfaces 165 on the distal cap 164 may be maroon in color while the non-gripping surfaces on the housing may be grey in color.

Figure 8 is a top view of an exemplary proximal terminal end 172 for covering the proximal end of the housing. In an exemplary embodiment, the exterior surface of the proximal terminal end 172 may lack any overmolded gripping surfaces. In other exemplary embodiments, at least part of the exterior surface of the proximal terminal end 172 may be overmolded with one or more gripping surfaces 173 to facilitate gripping of the proximal portion of the device. In an exemplary embodiment, the entire exterior surface of the proximal terminal end 172 may be covered by an overmolded gripping surface 173.

The overmolded gripping surfaces 173 may be formed of any suitable material that provides a first soft and high-friction touch perception to a user, as compared to the portions of the device that lack an overmolded gripping surface which provide a second soft and low-friction touch perception to a user. The difference in the sensory perceptions provides a touch affordance to a user, indicating that the device is to be gripped at regions provided with the overmolded gripping surfaces.

In an exemplary embodiment, the overmolded gripping surfaces 173 may be formed of a first type of material having a soft, high-friction touch perception, while the non-gripping surfaces are formed of a second type of material having a harder, lower-friction touch perception. Exemplary overmolded gripping surfaces 173 may be formed of materials having any suitable material grade and hardness for providing a soft, high-friction touch perception to the user. Exemplary overmolded gripping surface materials may include, but are not limited to, rubber (for example, having a durometer of 50A in one embodiment), thermoplastic elastomers (TPEs), thermoplastic vulcanizate (TPV), and the like. Exemplary thermoplastic elastomers that may be used to form exemplary overmolded gripping surfaces include, but are not limited to, TPEs from KRAIBURG, the Dynaflex™ TPE from PolyOne, the Versaflex™ TPE from PolyOne, the Versollan™ TPE from PolyOne, the OnFlex™ TPE from Polyone, and the like. Exemplary thermoplastic vulcanizates that may be used to form exemplary overmolded gripping surfaces include, but are not limited to, the Santoprene™ thermoplastic from ExxonMobil and the like. In an exemplary embodiment, the overmolded gripping surfaces 173 may be colored differently from the non-gripping surfaces to provide a visual affordance to indicate which area of the device should be gripped. For example, the one or more overmolded gripping surfaces 173 on the proximal terminal end 172 may be maroon in color while the non-gripping surfaces on the housing may be grey in color.

In an exemplary embodiment, one or more ridges (that protrude from the exterior surface) and/or one or more grooves or divots (that are depressed into the exterior surface) may be provided on the exterior surface of the proximal terminal end 172 to further facilitate gripping of the proximal portion of the device. The shapes and locations of the ridges and/or grooves may be altered as desired, and any desired number

of ridges and/or grooves may be provided. In an exemplary embodiment, the overmolded gripping surfaces 173 may include textured surfaces to improve the tactile feel and further facilitate firm gripping of the device. In an exemplary embodiment, a wrap-around groove 174 may be provided around the circumference of the proximal terminal end 172 and a concave or recessed surface 176 may be provided at the top of the proximal terminal end 172 in order to orient and guide a user's hand and fingers to the device. For example, the concave or recessed surface 176 may accommodate a finger on the surface 176 while the user is performing an injection using the device.

In some exemplary embodiments, the housing 101, the removable distal cap 164 and/or the proximal terminal end 172 of the device 100 may further include graphics, symbols and/or numbers to facilitate use of the automatic injection device. For example, the distal cap 164 may include a depiction of an arrow on an outer surface pointing towards the distal end of the device to indicate how the device should be held relative to the patient (i.e., with the distal end adjacent to the injection site). One of ordinary skill in the art will recognize that the automatic injection device may have any suitable graphics, symbols and/or numbers to facilitate patient instruction, or the automatic injection device may omit such graphics, symbols and/or numbers.

Figure 9 is a flowchart of an exemplary method of assembling an exemplary automatic injection device. In an exemplary embodiment, a housing of an exemplary automatic injection device may be provided in two or more separate housing components (for example, first and second body portion) that may be coupled together during assembly of the device.

In step 902, a first body portion of the housing is provided or formed. In step 904, one or more gripping surfaces are overmolded on corresponding recesses on the

exterior surface of the first body portion to facilitate gripping and manipulation of the device during an injection.

In step 906, a second body portion of the housing is provided or formed. In step 908, one or more gripping surfaces are overmolded on corresponding recesses on the exterior surface of the second body portion to facilitate gripping and manipulation of the device during an injection.

In step 910, a proximal terminal end of the housing is provided or formed. In step 912, one or more gripping surfaces are overmolded on corresponding recesses on the exterior surface of the proximal terminal end to facilitate gripping and manipulation of the device.

In step 914, a removable distal cap of the housing is provided or formed. In step 916, one or more gripping surfaces are overmolded on corresponding recesses on the exterior surface of the distal cap to facilitate removal of the distal cap before performing an injection.

In step 918, a firing button of the housing is provided or formed. In step 920, one or more gripping surfaces are overmolded on the exterior surface of the firing button to facilitate activation of the firing button to perform an injection.

In step 922, one or more internal components of the automatic injection device may be positioned in a cavity defined between the upper and second body portions. Exemplary device components may include, but are not limited to, a container (e.g., a syringe) pre-filled with a therapeutic agent for injecting into a patient, an injection needle coupled to a distal end of the container, a container advancement mechanism for advancing the container within and relative to the housing toward the injection site and

for ejecting the therapeutic agent from the container during an injection, a firing button for activating the container advancement mechanism, and the like.

In step 924, the upper and second body portions may be cooperatively engaged to form a body assembly that encloses and holds the internal components within the cavity. In an exemplary embodiment, the body portions may be coupled at their
5 peripheral edges. Any suitable coupling or joining may be used in step 924 including, but not limited to, bonding, gluing, ultrasonic welding, friction fit, snap fit, interference fit, screws, corresponding protrusions and recesses, and the like.

In step 926, the removable distal cap may be removably coupled at a distal end
10 of the body assembly to cover an injection needle or a needle shield that, in turn, covers the injection needle.

In step 928, the proximal terminal end may be coupled at a proximal end of the body assembly.

Any suitable fabrication technique may be used to form any of the device
15 components including, but not limited to, injection molding. The device components may be formed of any suitable material including, but not limited to, plastics, thermoplastics, polycarbonates, metals, and the like.

It is noted that the order of the steps discussed herein may be altered as desired and that other fabrication steps/techniques are possible and are considered within the
20 spirit and scope of the present invention.

Automatic Injection Device User Tests

Forty-four test participants were recruited to test both the exemplary automatic injection devices having overmolded gripping surfaces of the present invention and four alternate automatic injection devices without such gripping surfaces. A majority of the participants were suffering from rheumatoid arthritis (RA) at the time of the test. The participants were diagnosed with RA from 1 to 40 years ago, with an average age of diagnosis of 9 years ago. Four participants were suffering from Crohn's disease at the time of the test.

Test Procedure

Each test participant tested the different exemplary automatic injection device configurations. In particular, in an example device use phase, each test participant performed a simulated injection (i.e., an injection with clipped needles and no medicament) using the devices. After he/she performed a simulated injection, each test participant was asked a series of follow-up questions designed to assess the participant's approval of the form and function of the devices. These questions included questions on, for example, the size, shape, ease of handling, comfort of holding, overall user experience, and the like.

Device Handling and Gripping

Upon performing simulated injections using the different device configurations, test participants were asked to provide feedback and comparative ratings on handling and grip, overall ease of use, and comfort in performing the injection steps. All device configurations were rated on a scale of 1 (very negative) to 10 (very positive).

Most test participants (58%) strongly preferred the handling and grip of the example device configuration of the present invention, compared to four alternate device configurations that did not include overmolded gripping surfaces. Test participants particularly liked the rubberized overmolded grips on the side of the example device and
5 its relatively large size, which made the example device easy and comfortable to hold. The rubberized overmolded grips were the primary factor in participants' high ratings of the example device configuration for handling and grip as taught herein.

Furthermore, a correlation analysis was performed on hand dysfunction using the Cochin hand disability scale with the ratings provided for certain usability factors:
10 handling and gripping, ease of use, ease of starting and performing an injection, comfort of performing injection, acceptability and overall preference. For several usability factors, there was a significant positive correlation between Cochin scores and the example device configuration of the present invention, which indicates that this example device configuration is well-suited for those with hand dysfunction.

15 **Comfort of Device Holding and Use**

Upon performing simulated injections in the example device use phase, test participants were asked to rate the comfort of holding the example device configuration of the present invention and four alternate device configurations that did not include any overmolded gripping surfaces. Test participants rated each device configuration on a
20 scale from 1 (very low confidence) to 7 (very high confidence). Most test participants favored the example device configuration of the present invention for comfort in performing injection steps, with 45% rating it the highest.

Ease of Device Use and Handling

Upon initial exposure to the example device and before receiving instructions or a demonstration on use, test participants were asked about the perceived ease of use of the example device configuration of the present invention and four alternate device configurations that did not include any overmolded gripping surfaces. Test participants
5 rated each device configuration on a scale from 1 (very difficult) to 7 (very easy). All of the device configurations received high ratings for their perceived ease of use.

Upon performing simulated injections in the actual device use phase, test participants were asked to rate the ease of handling each device configuration. Test
10 participants rated each device configuration on a scale from 1 (very low confidence) to 7 (very high confidence). Furthermore, upon performing simulated injections using the device configuration in the third actual device use phase, test participants were also asked to rate the configurations on their overall ease of use on a scale of 1 (very
difficult) to 10 (very easy).

15 Most test participants (42%) found the example device configuration of the present invention easiest to use compared to four alternate device configurations that did not include overmolded gripping surfaces. Overall, the example device configuration of the present invention received a high average rating of 7.97 out of 10.0.

Device Size

20 Upon performing simulated injections in the example device use phase, test participants were asked to rate the overall size of the example device configuration of the present invention and four alternate device configurations that did not include any overmolded gripping surfaces on a scale of 1 (very low confidence) to 7 (very high

confidence). All of the device configurations generally received positive ratings for their overall shape. In general, test participants who struggled to form a tight fist preferred larger devices. The example device configuration of the present invention generally received the highest ratings.

5 Device Shape

Upon performing simulated injections in the actual device use phase, test participants were asked to rate the overall shape of the example device configuration of the present invention and four alternate device configurations that did not include any overmolded gripping surfaces on a scale of 1 (very low confidence) to 7 (very high confidence).

All of the device configurations generally received positive ratings for their overall size. In general, test participants who struggled to form a tight fist preferred larger devices. With respect to the example device configuration of the present invention, many participants found that the shape fit nicely in their hand.

15

The appropriate components and methods of all cited references may be selected for the invention and embodiments thereof. Still further, the components and methods identified in the Background section are integral to this disclosure and can be used in conjunction with or substituted for components and methods described elsewhere in the disclosure within the scope of the invention.

IV. Equivalents

In describing exemplary embodiments, specific terminology is used for the sake of clarity. For purposes of description, each specific term is intended to, at least, include all technical and functional equivalents that operate in a similar manner to accomplish a similar purpose. Additionally, in some instances where a particular exemplary embodiment includes a plurality of system elements or method steps, those elements or steps may be replaced with a single element or step. Likewise, a single element or step may be replaced with a plurality of elements or steps that serve the same purpose. Further, where parameters for various properties are specified herein for exemplary embodiments, those parameters may be adjusted up or down by 1/20th, 1/10th, 1/5th, 1/3rd, 1/2nd, and the like, or by rounded-off approximations thereof, unless otherwise specified. Moreover, while exemplary embodiments have been shown and described with references to particular embodiments thereof, those of ordinary skill in the art will understand that various substitutions and alterations in form and details may be made therein without departing from the scope of the invention. Further still, other aspects, functions and advantages are also within the scope of the invention.

Exemplary flowcharts are provided herein for illustrative purposes and are non-limiting examples of methods. One of ordinary skill in the art will recognize that exemplary methods may include more or fewer steps than those illustrated in the exemplary flowcharts, and that the steps in the exemplary flowcharts may be performed in a different order than shown.

What is claimed is:

1. An injection device, comprising:

a housing enclosing a cavity for accommodating a container, a proximal portion of the housing having a tapered tubular structure with a substantially oval cross-section;

a first overmolded gripping surface extending longitudinally along a portion of the housing on a first exterior surface of the housing;

a second overmolded gripping surface extending longitudinally along a portion of the housing on a second exterior surface of the housing, the first exterior surface and the second exterior surface located on opposing sides of the housing;

a first concave portion disposed in the first exterior surface of the housing between the first overmolded gripping surface and a proximal terminal end of the housing; and

a second concave portion disposed in the second exterior surface of the housing between the second overmolded gripping surface and the proximal terminal end of the housing.

2. The injection device of claim 1, wherein the first and second overmolded gripping surfaces on the housing include one or more grooves or ridges for facilitating gripping and manipulation of the injection device.

3. The injection device of claim 1, wherein the first and second overmolded gripping surfaces on the housing are formed of a first material having a first touch perception, and non-gripping surfaces on the housing are formed of a second material having a second touch perception.

4. The injection device of claim 1, wherein the first and second overmolded gripping surfaces on the housing are formed of a first material having a first hardness, and non-gripping surfaces on the housing are formed of a second material having a second, higher hardness.

5. The injection device of claim 1, wherein the first and second overmolded gripping surfaces on the housing have a different color than non-gripping surfaces on the housing.

6. The injection device of claim 1, further comprising:

a removable distal cap for protectively covering an injection needle couplable to the container, an exterior surface of the distal cap including an overmolded gripping surface for facilitating gripping and removal of the distal cap.

7. The injection device of claim 6, wherein the exterior surface of the distal cap includes one or more grooves or ridges for facilitating gripping and removal of the distal cap.

8. The injection device of claim 1, further comprising:

a firing button protruding from an aperture in the housing and including an overmolded contact surface for facilitating actuation of the firing button by a user.

9. The injection device of claim 8, wherein the firing button is positioned along a transverse axis perpendicular to a longitudinal axis of the device.

10. The injection device of claim 9, further comprising:

a recessed surface provided adjacent to the firing button.

11. The injection device of claim 10, wherein the recessed surface is provided surrounding the firing button.

12. The injection device of claim 1, further comprising:

a proximal terminal end for covering a proximal end of the injection device, the proximal terminal end having an overmolded exterior surface.
13. The injection device of claim 12, wherein a top surface of the proximal terminal end includes a recessed surface for directing and facilitating gripping of the injection device.
14. The injection device of claim 1, further comprising:

a transparent inspection window disposed in the housing to allow inspection of the contents of the container.
15. The injection device of claim 14, wherein, at the end of an injection, the inspection window is filled with a visual indicator.
16. The injection device of claim 1, wherein a proximal portion of the device configured for gripping by a user's hand has an irregular tubular shape in which a front face and an opposite back face are planar and in which first and second side faces are convex, for ergonomic and reliable gripping of the proximal portion by a user's hand.
17. The injection device of claim 16, wherein the first and second overmolded gripping surfaces are disposed at the proximal portion of the device and extend across portions of the first and second side faces.
18. The injection device of claim 1, wherein the housing comprises a plurality of housing components cooperatively engaged to define the cavity therein.
19. A method for manufacturing an injection device, the method comprising:

providing a housing enclosing a cavity for accommodating a container, the housing having a first concave portion disposed in a first exterior surface of the housing between a first gripping surface and a proximal terminal end of the housing, a second concave portion disposed

in a second exterior surface of the housing between a second gripping surface and the proximal terminal end of the housing, and a proximal portion of the housing having a tapered tubular structure with a substantially oval cross-section;

overmolding, on the housing, the first gripping surface extending longitudinally along a portion of the housing on the first exterior surface of the housing; and

overmolding, on the housing, the second gripping surface extending longitudinally along a portion of the housing on the second exterior surface of the housing opposite to the first exterior surface.

20. The method of claim 19, wherein the first and second gripping surfaces on the housing include one or more grooves or ridges for facilitating gripping and manipulation of the injection device.

21. The method of claim 19, wherein the first and second gripping surfaces on the housing are formed of a first material having a first touch perception, and non-gripping surfaces on the housing are formed of a second material having a second touch perception.

22. The method of claim 19, wherein the first and second gripping surfaces on the housing are formed of a first material having a first hardness, and non-gripping surfaces on the housing are formed of a second material having a second, higher hardness.

23. The method of claim 19, further comprising:

overmolding a gripping surface on an exterior surface of a distal cap to facilitate gripping and removal of the distal cap; and

coupling the distal cap to a distal end of the housing for protectively covering an injection needle.

24. The method of claim 23, wherein the exterior surface of the distal cap includes one or more grooves or ridges for facilitating gripping and removal of the distal cap.

25. The method of claim 19, further comprising:

overmolding a gripping surface on a firing button to facilitate activation of the firing button; and

providing the firing button within the cavity so that part of the firing button protrudes from an aperture in the housing.

26. The method of claim 25, wherein the firing button is positioned along a transverse axis perpendicular to a longitudinal axis of the device.

27. The method of claim 25, further comprising:

forming a recessed surface abutting the firing button.

28. The method of claim 27, wherein the recessed surface is provided surrounding the firing button.

29. The method of claim 19, further comprising:

overmolding a gripping surface on an exterior surface of a proximal terminal end; and

coupling the proximal terminal end to a proximal end of the housing.

30. The method of claim 29, wherein a top surface of the proximal terminal end includes a recessed surface for facilitating gripping of the injection device.

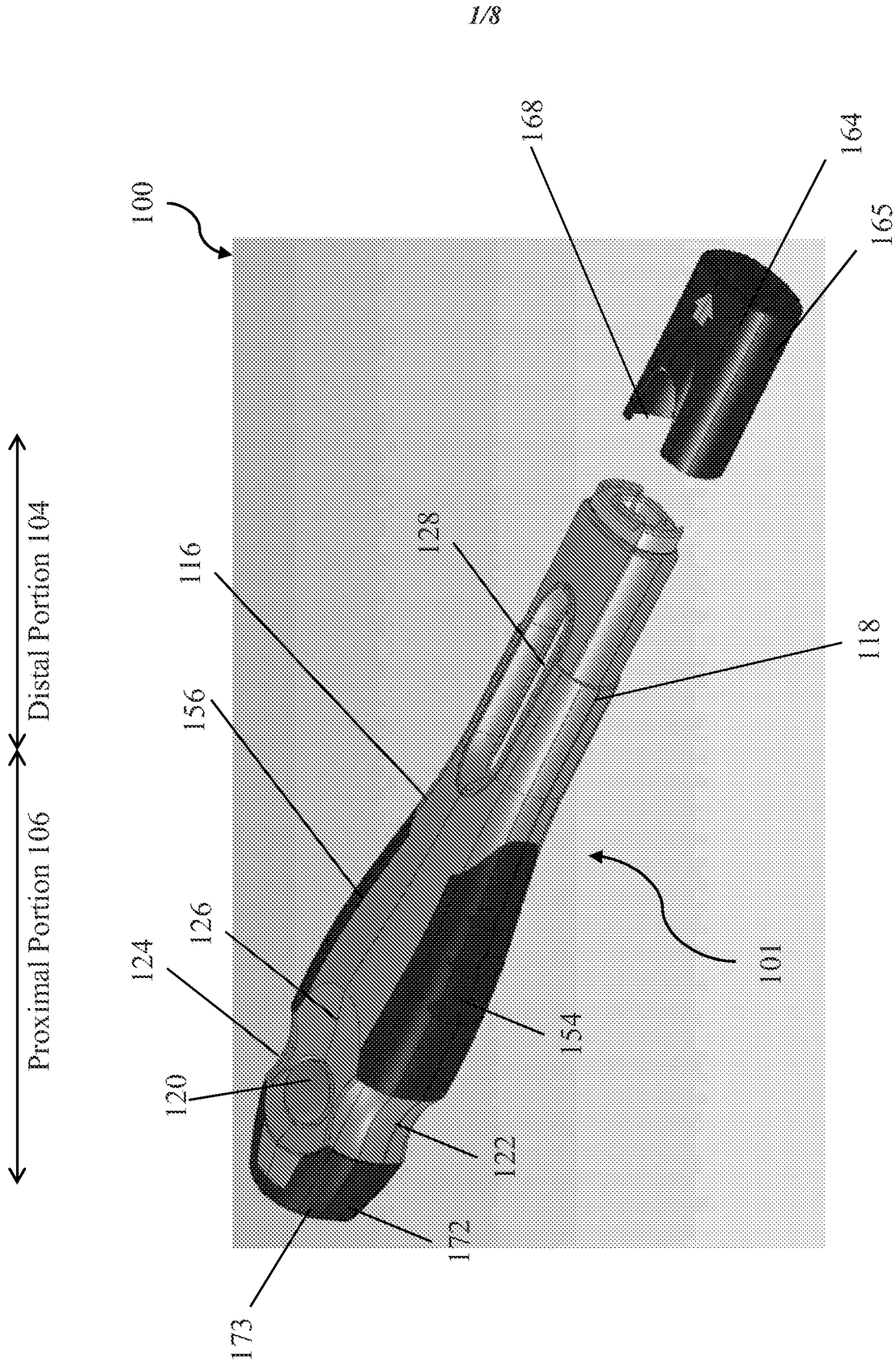

Figure 1

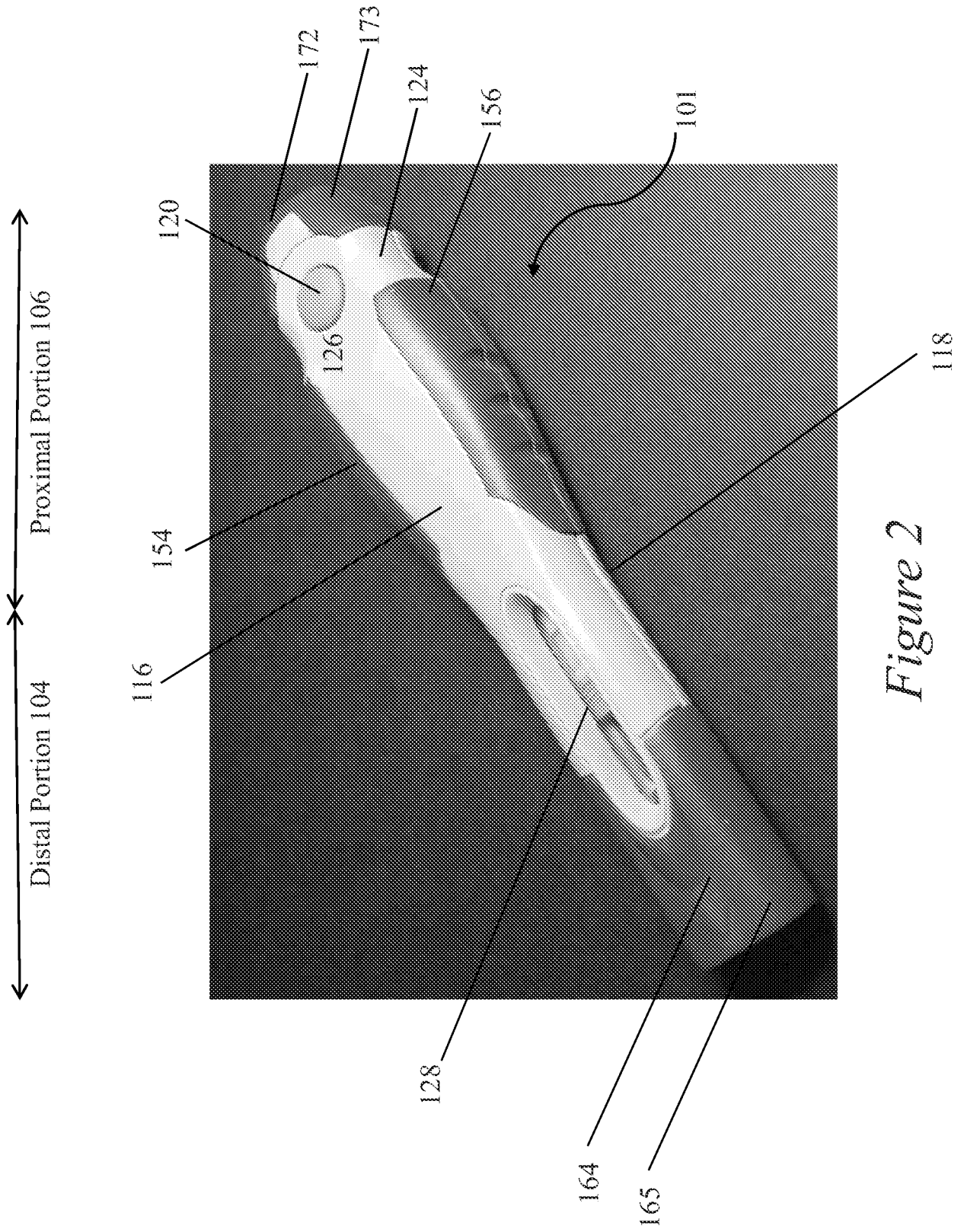
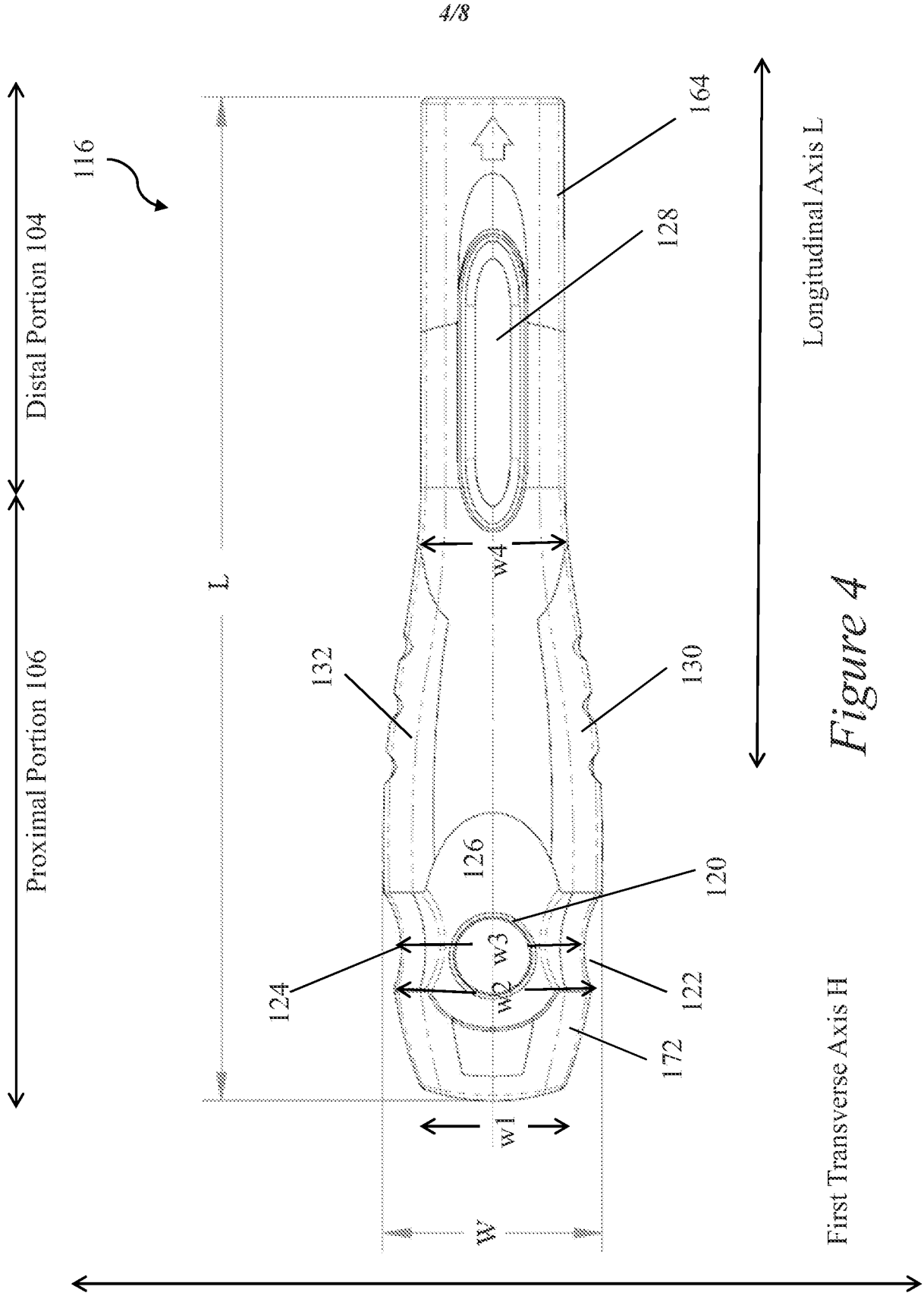
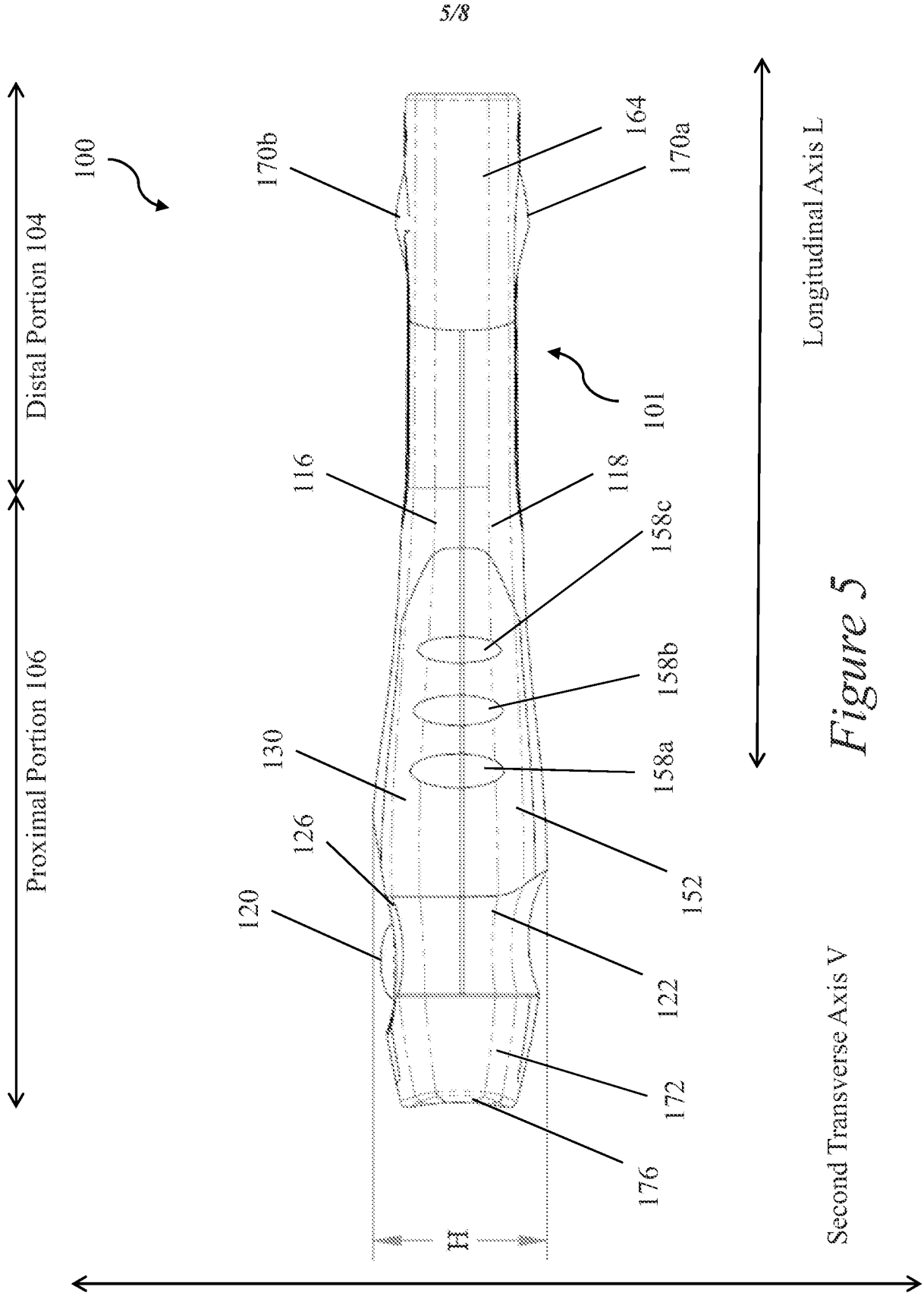
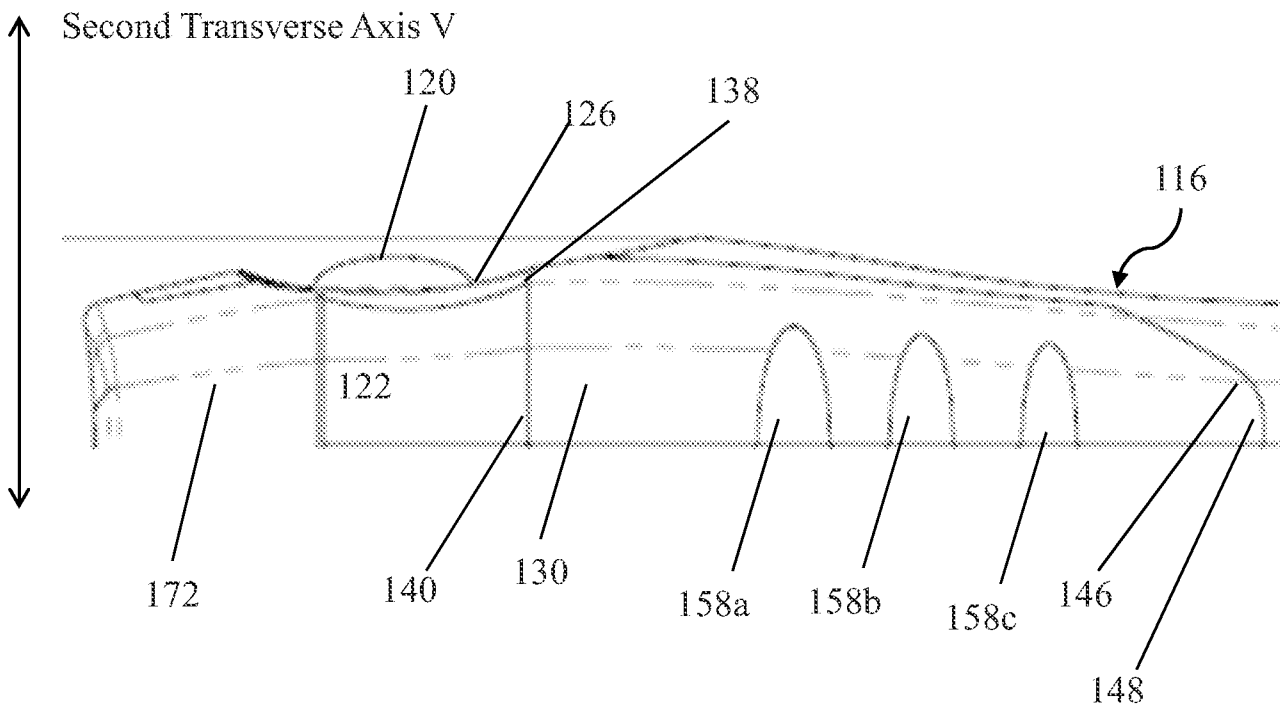
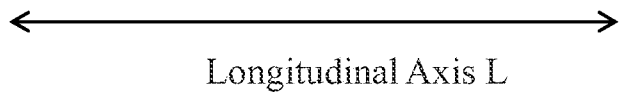
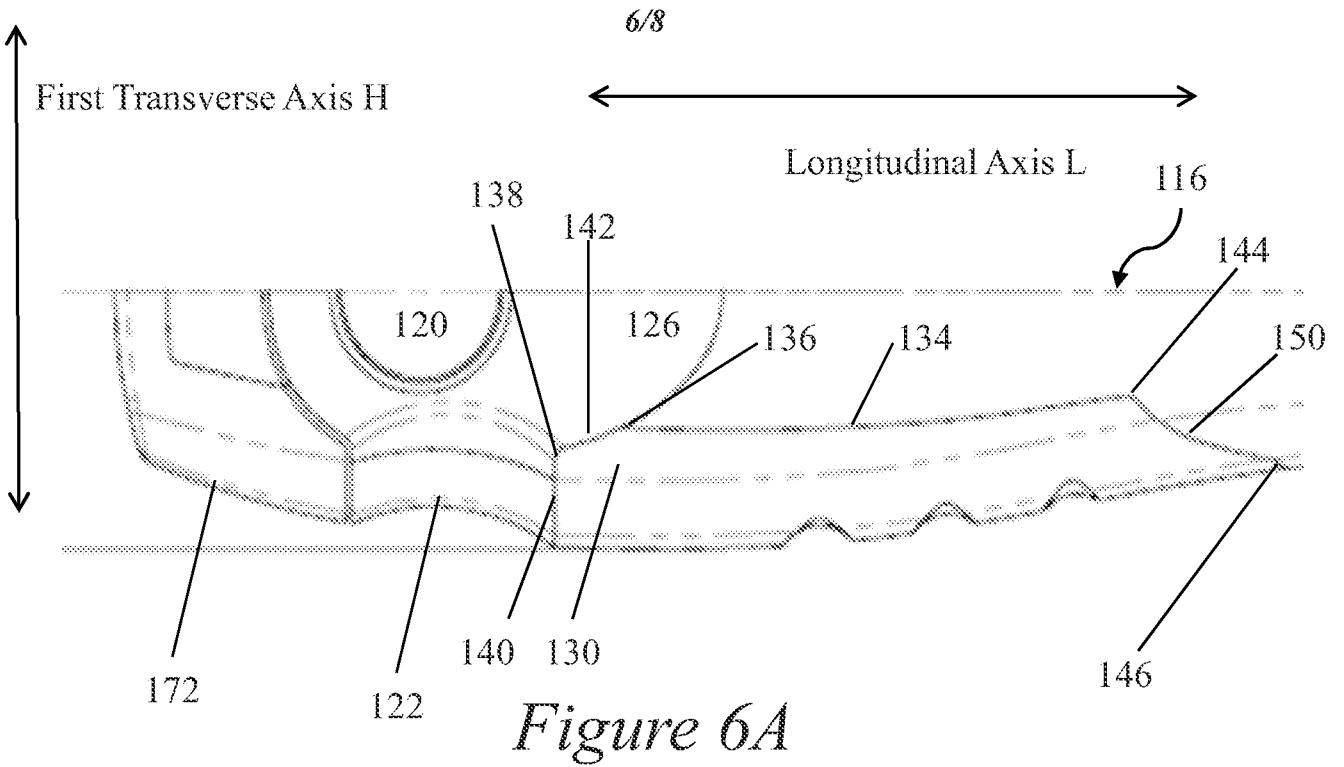

Figure 2







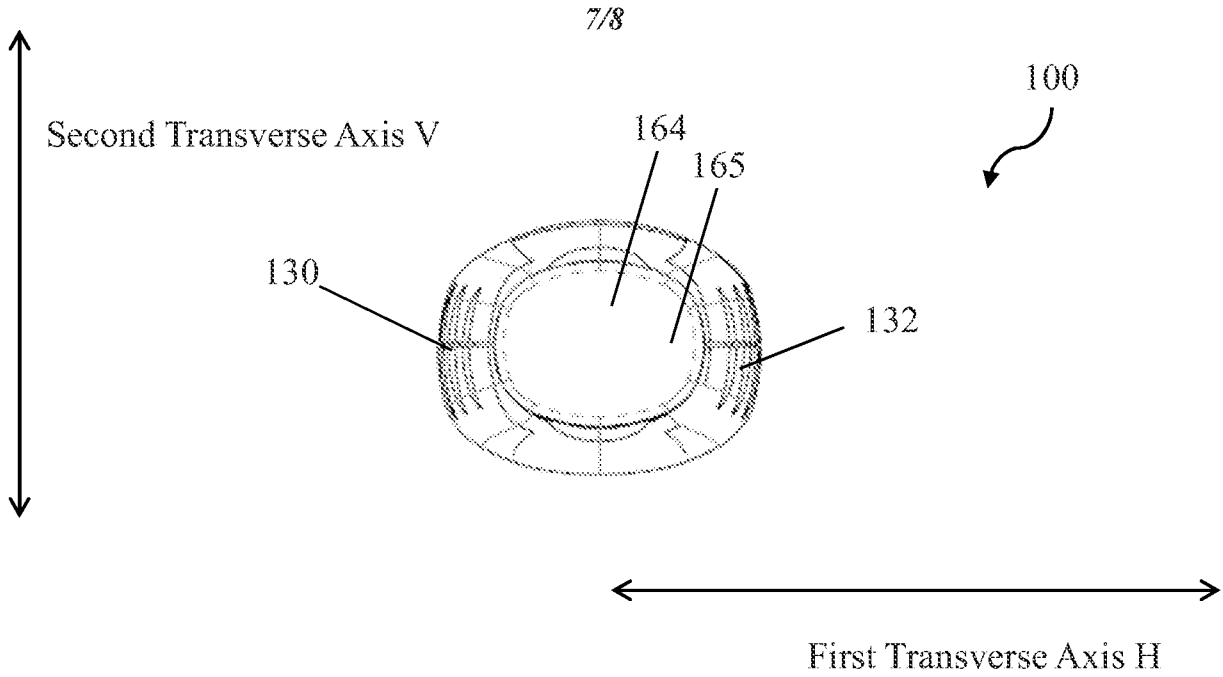

Figure 7

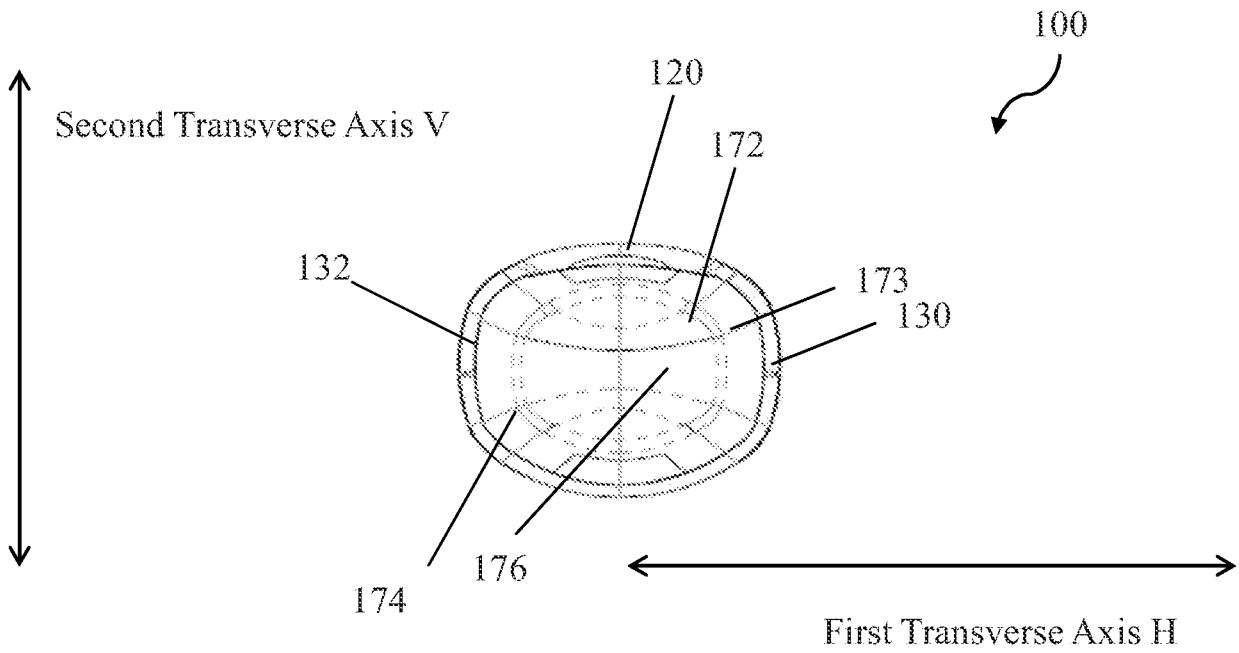

Figure 8

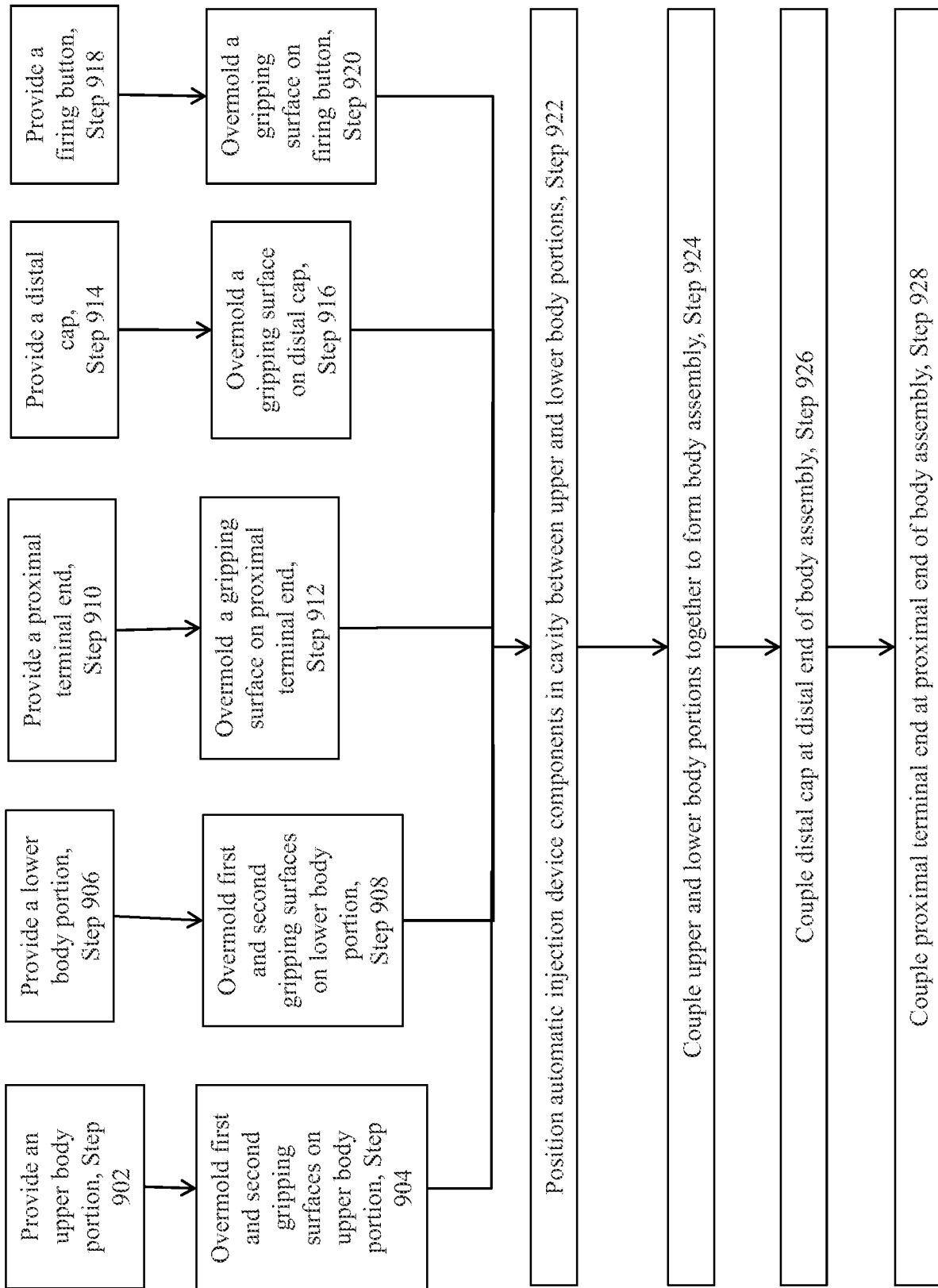

Figure 9

