

(19)
(12)

(KR)
(Y1)

(51) 。 Int. Cl.7
B26F 1/02

(45)
(11)
(24)

2004 11 10
20-0367261
2004 11 01

(21) 20-2004-0021391
(22) 2004 07 27

(73) 20 16

(72) , - 402 182 4

, - 508 8

(74)

:

(54)

, , . 4

가 .

1

1 ,

2 ,

3 ,

4 ,
 5 ,
 6 ,
 7 .
 * *

10 : 11 :
 12 : X 13 : Y
 14 : 15 :
 16 : 20 :
 21 : 211 :
 22 : 23 :
 24 : 25 :
 26 : 261 :
 27 : 28 :
 30 : 31 :
 32 : 33 :
 34 : 35 :
 36 : 37 :
 41 : 42 :
 43 : 44 :
 45 : 46 :

가

(921) 가 6 (922) (90) (91) (92)
 (926) (927) (923) (925) (924)
 (923) (928) (911) (91) (928)
 (929)

1) 가 (933) (934) (scanning device; 93) (931) (935) (936) (931) (933) (932)가 (912) (933) (934) (937) (91) (926) (938) (939) (939)

(912) (939) (933) (934) 가 (912) 가 (93) X Y

7 가 (939) (931) (93) (925), (928) (934) (935) (934) (934) (935) (932), (935) (932) (935) (934) (935) (934) (935) 가 4 가

가 가 가 가 가 가

가 가

1 4 (20) (11) X (14) (20) (30), (12) Y (10), (30) (10) (20), (40) (10) (13) (15) (10) (11) (2) (15) (window; 22)가 (21) (24)가 (30) (22) X (12) Y (13) (23) (25) (23, 24) 가 (27) (24) (15) (25) (26) (22) (30) (28) (28) (24) (1) (15) 가 (25) (28) (16) (24)

.
5 **6.** ,
가 ,

.
5 **7.** ,
 ,

.
1 **8.** 2 ,
 ,
가 ,

.
8 **9.** ,
가 가 ,

.
8 **10.** ,
가 ,

.
1 **11.** ,
가 ,
 ,

.
2 **12.** ,
가 ,
 ,

1

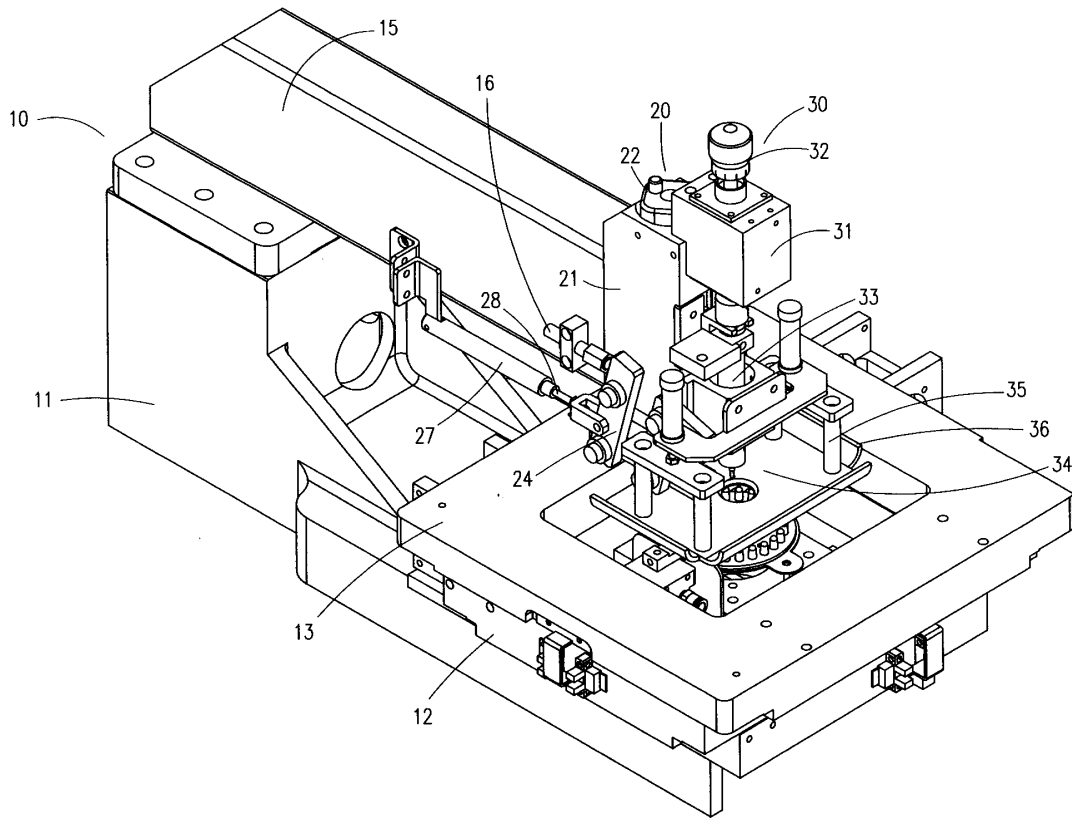

2

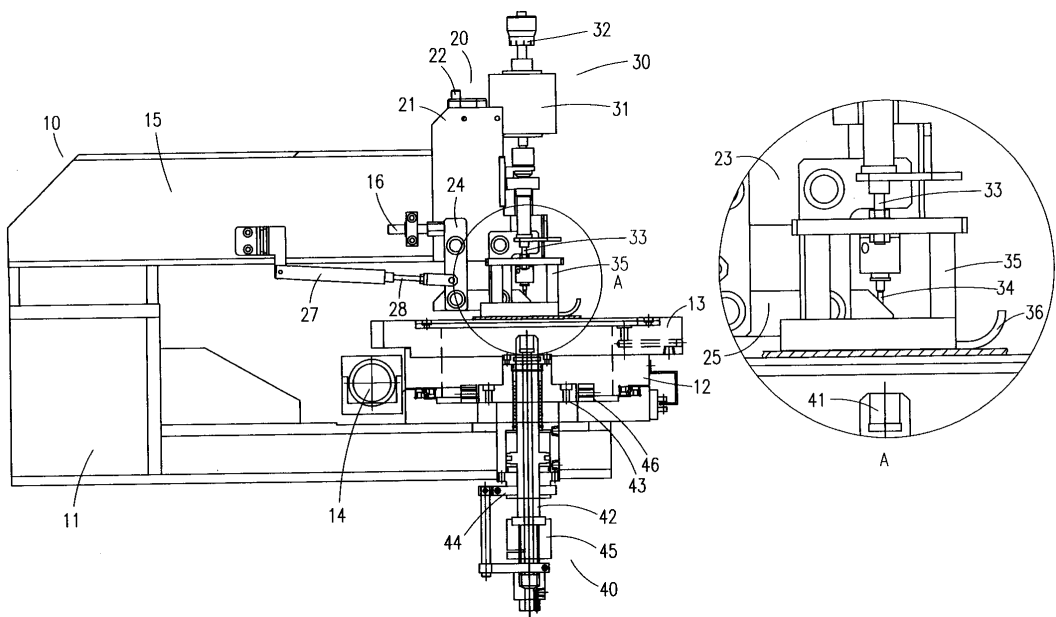

3

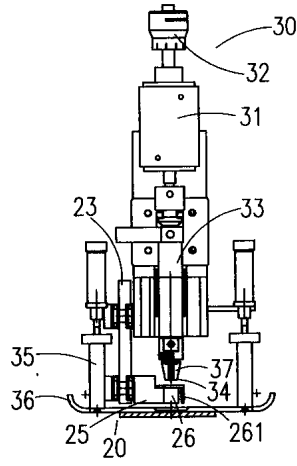

4

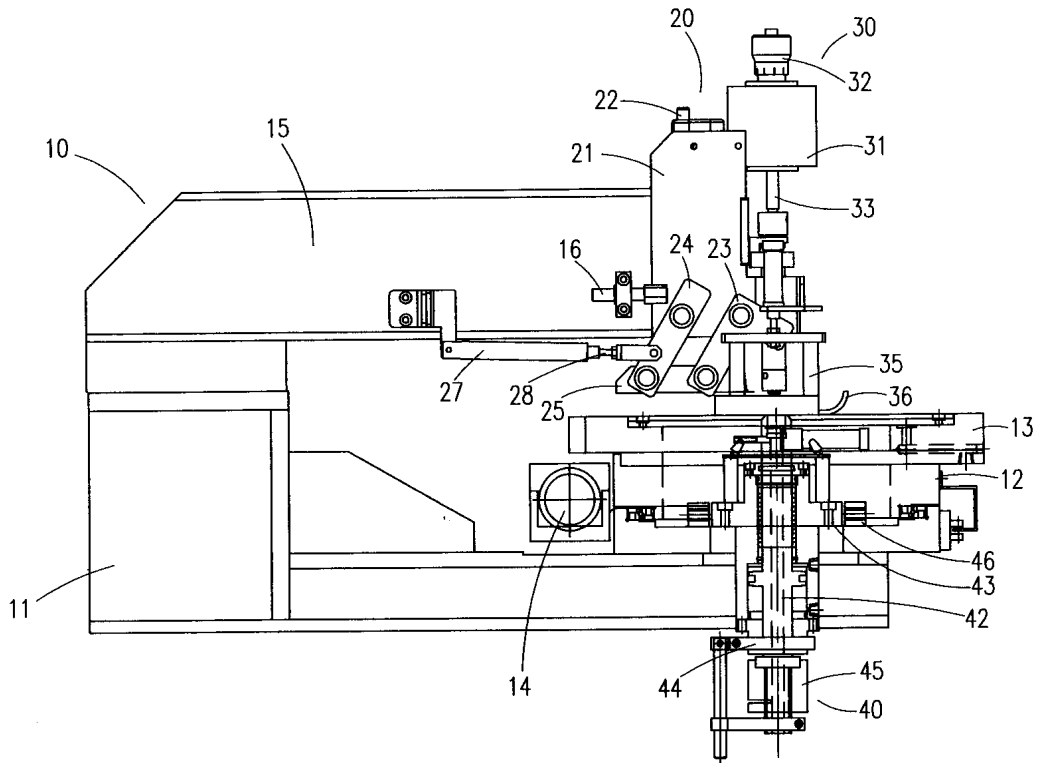

5

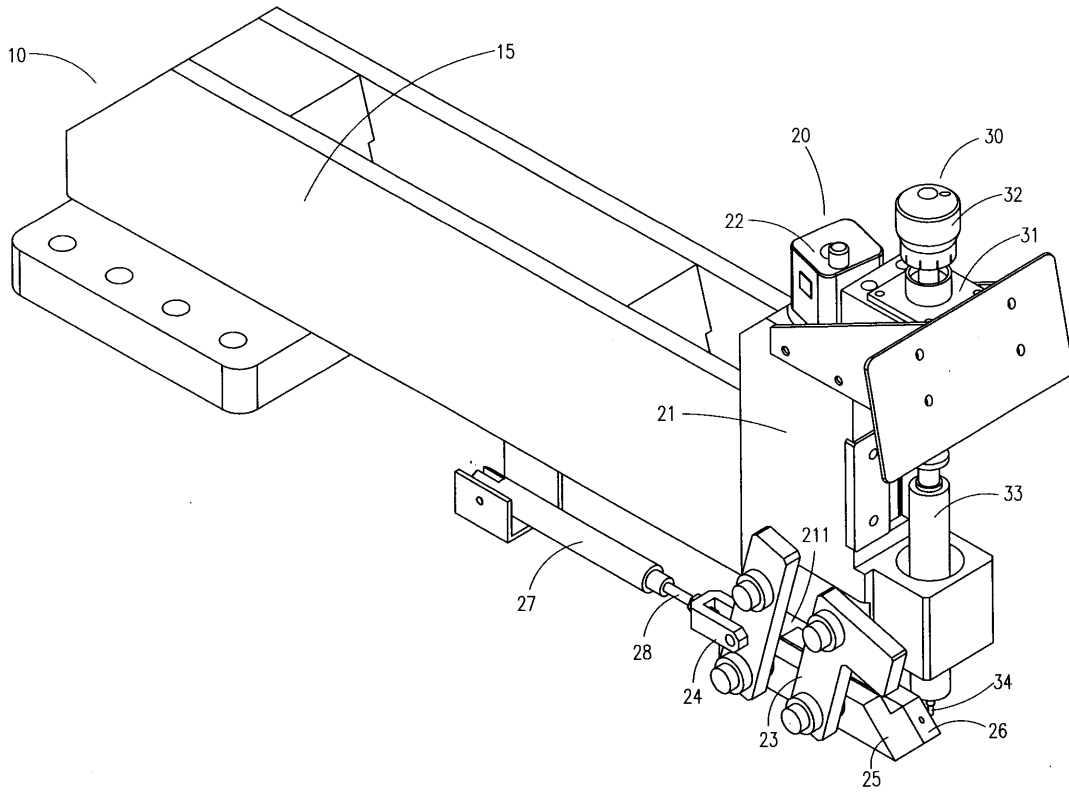

6

