

FIG 1

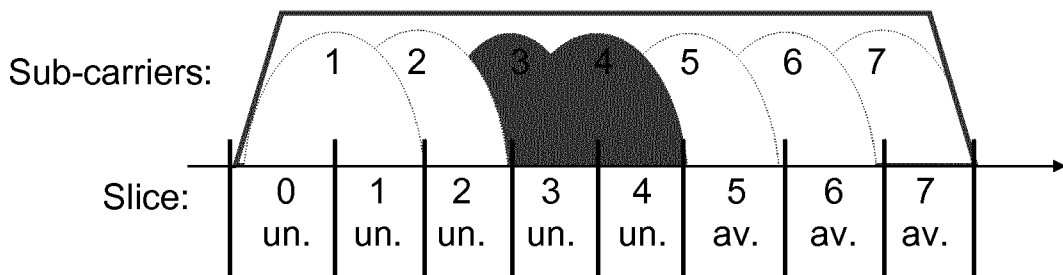
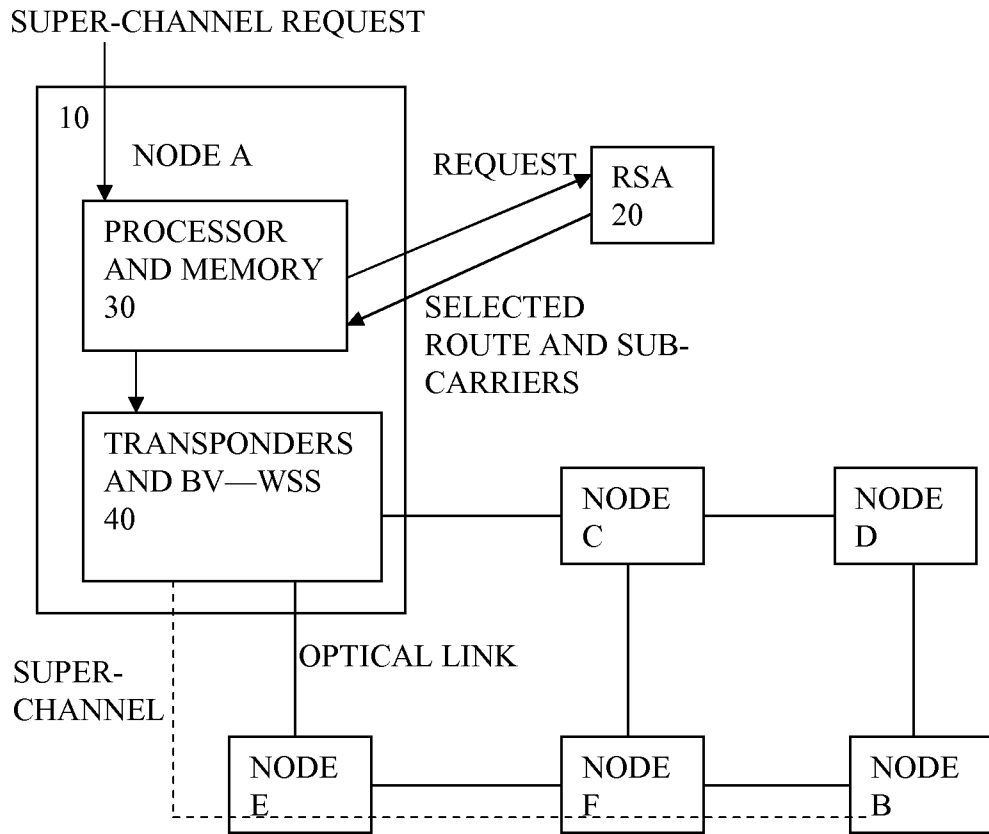

FIG 2

2 / 10

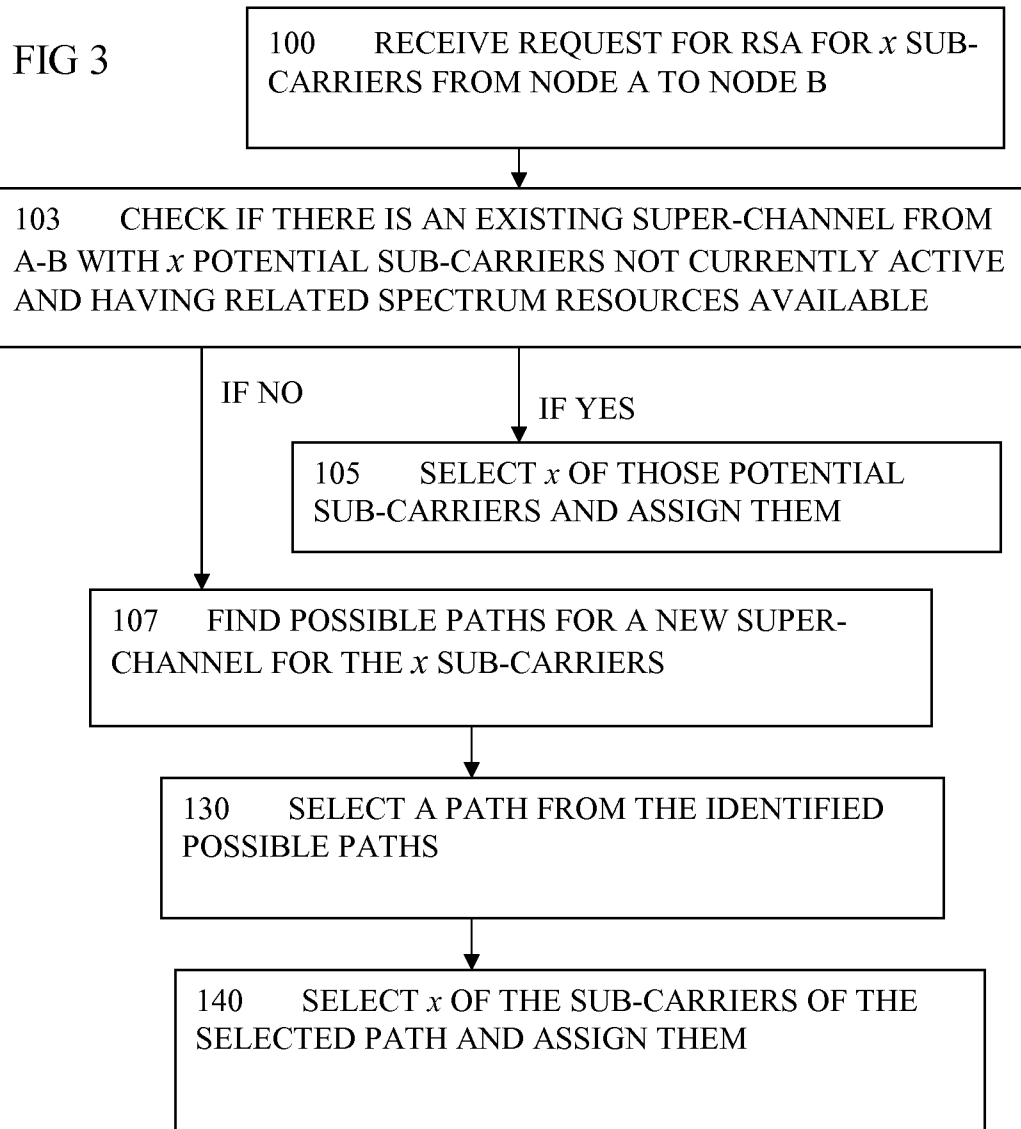

FIG 4

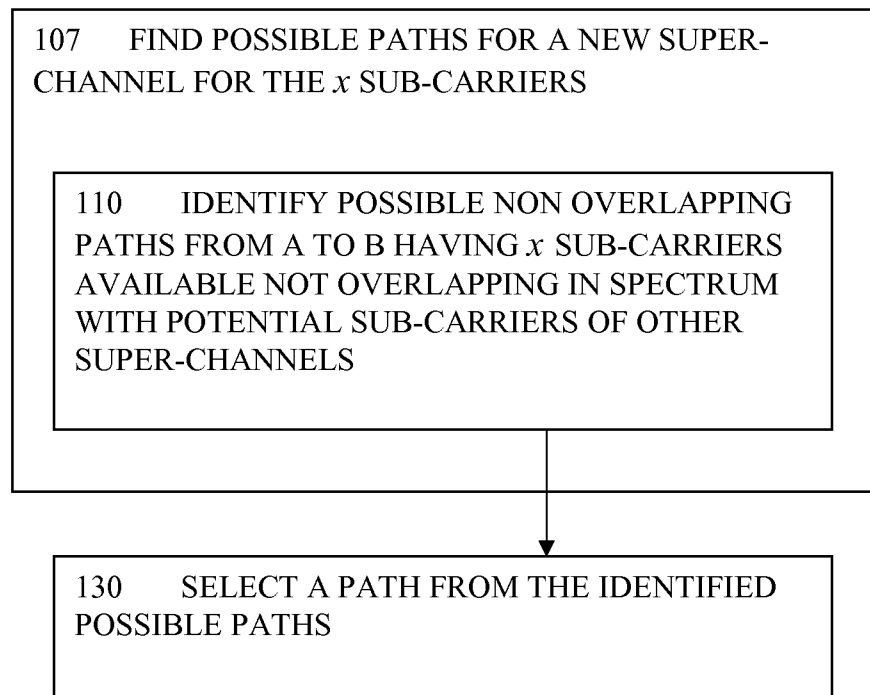

FIG 5

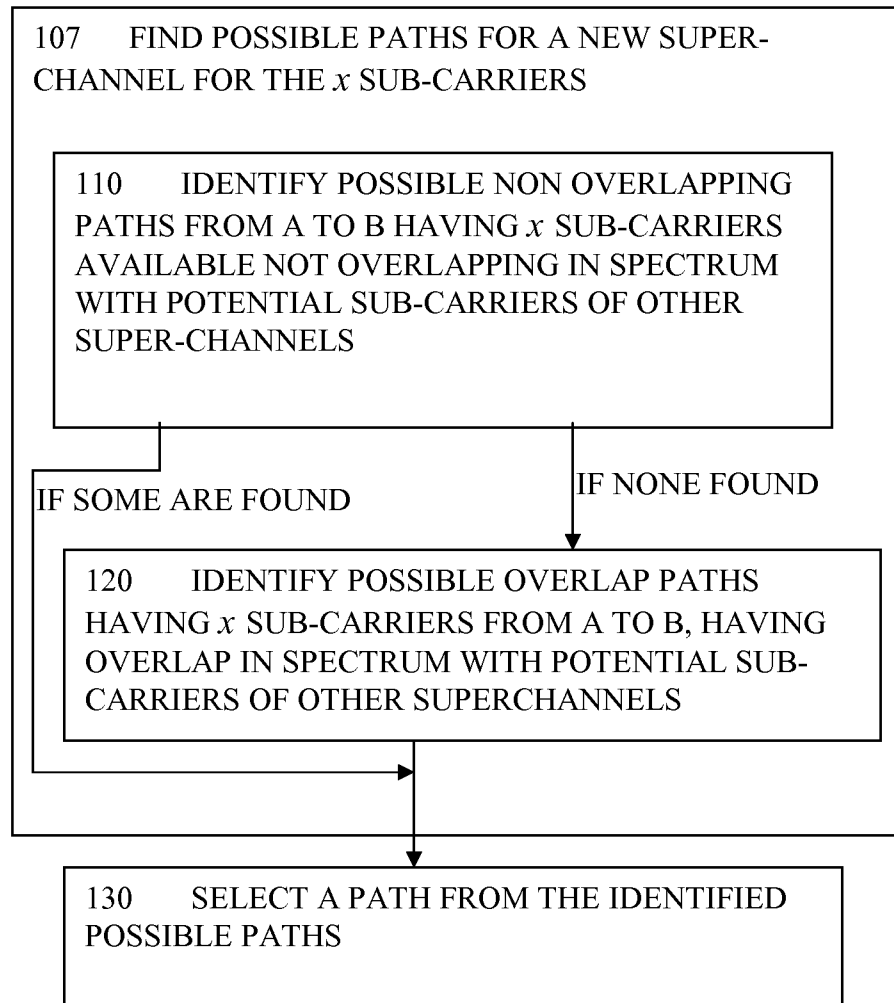

FIG 6

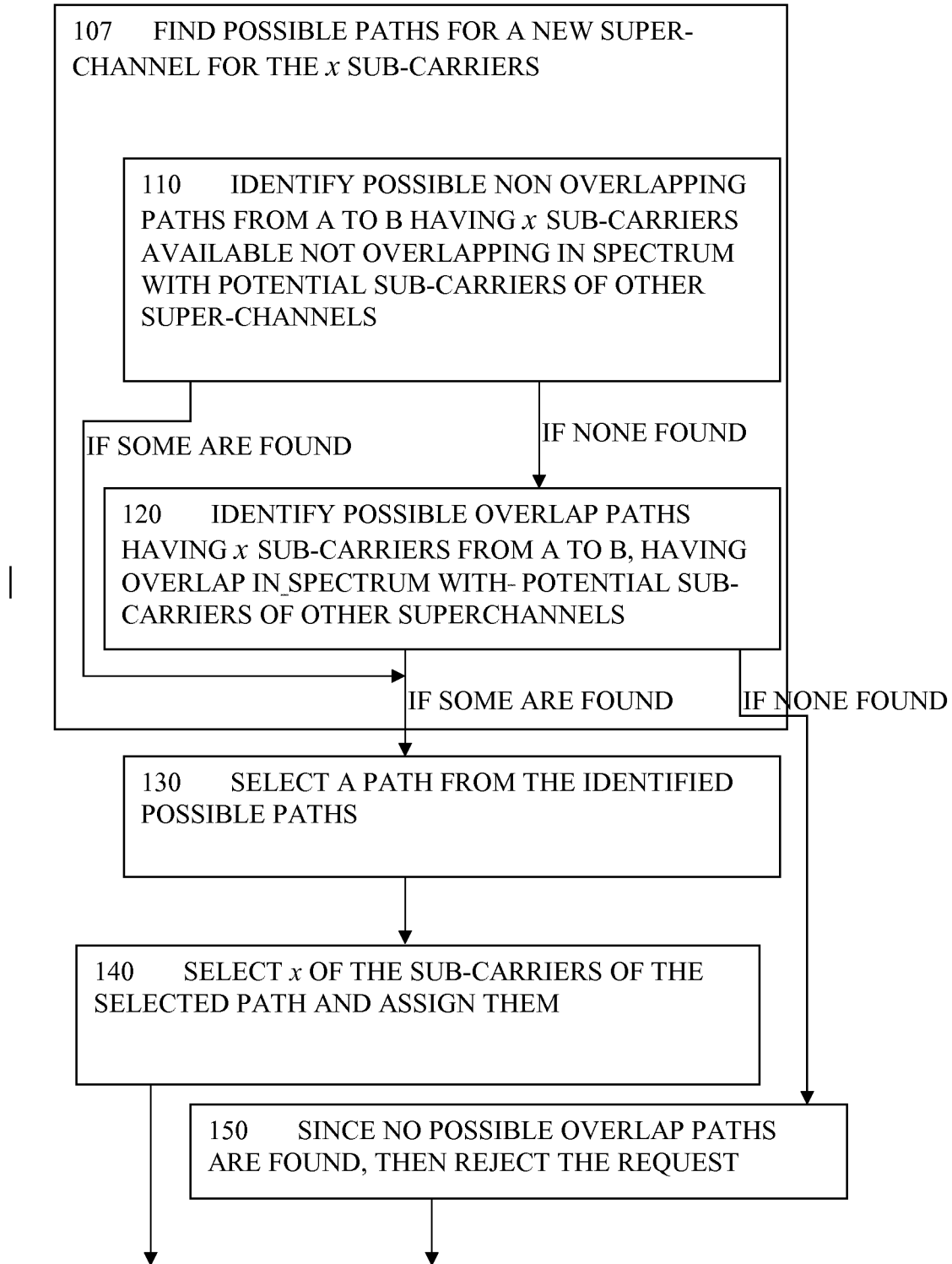

FIG 7

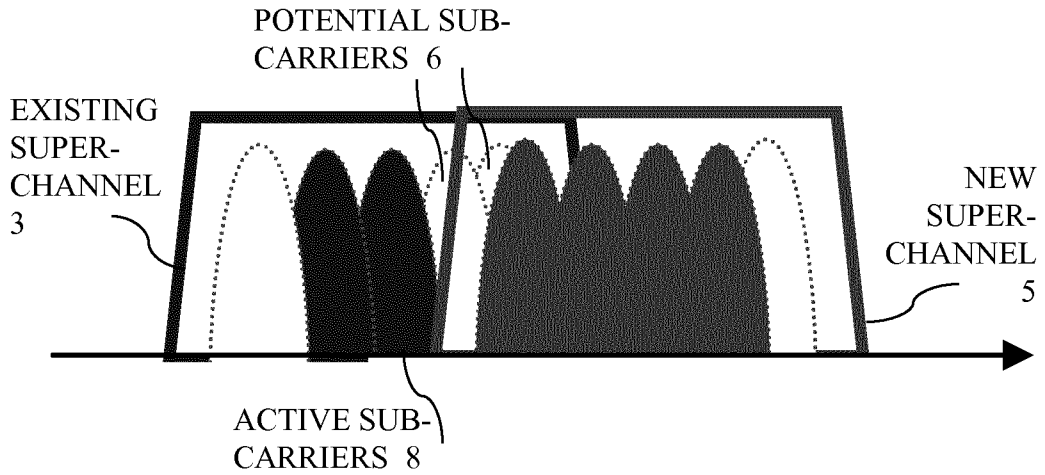
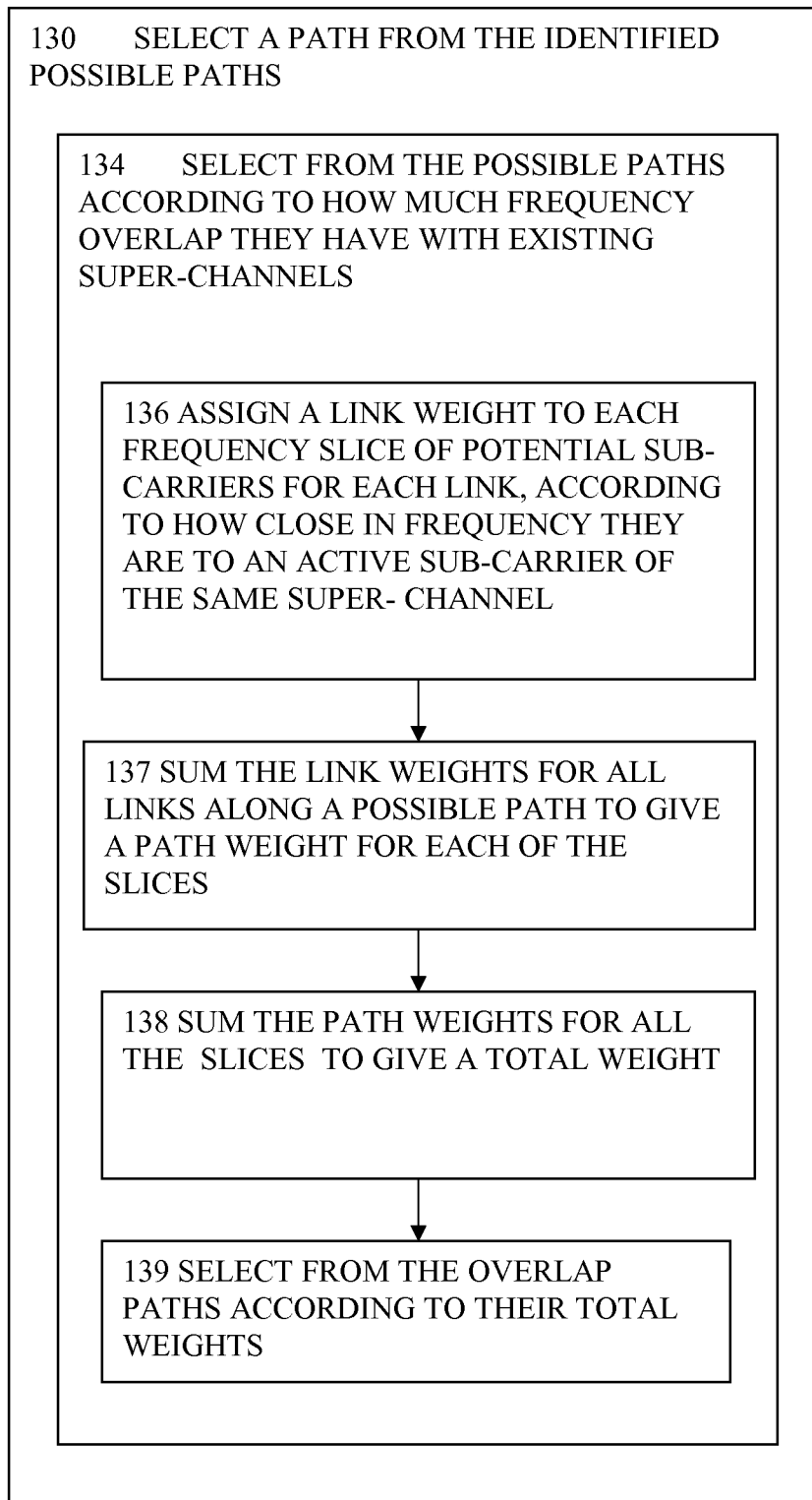

FIG 8

130 SELECT A PATH FROM THE IDENTIFIED POSSIBLE PATHS

134 SELECT FROM THE POSSIBLE PATHS ACCORDING TO HOW MUCH FREQUENCY OVERLAP THEY HAVE WITH EXISTING- SUPER-CHANNELS

FIG 9



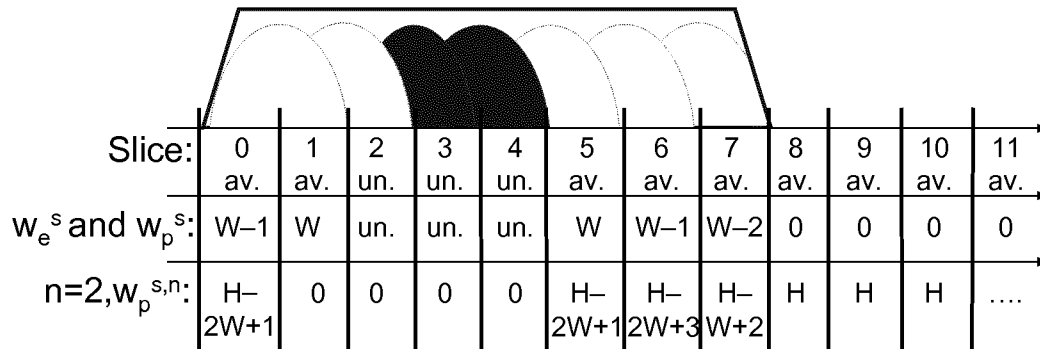

FIG 10

FIG 11

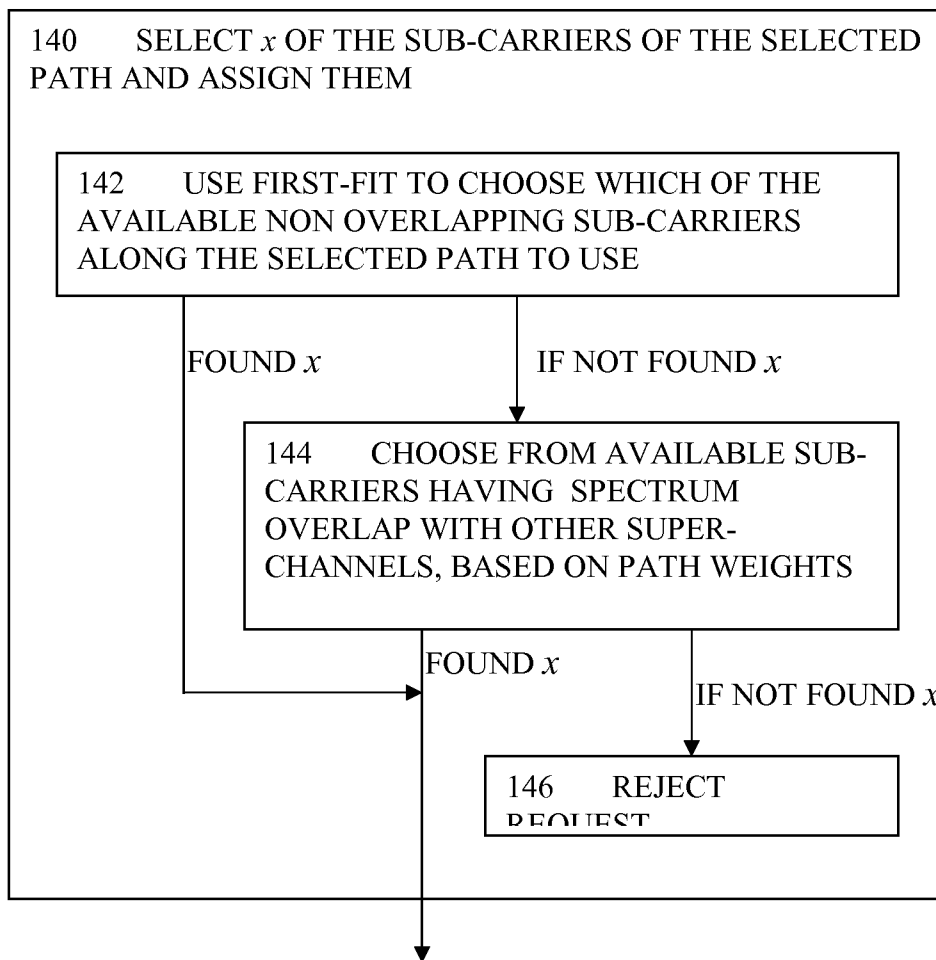

FIG 12

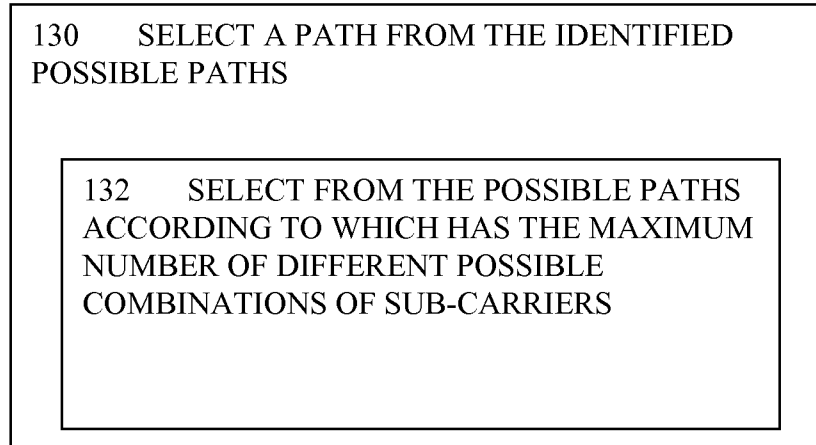

FIG 13

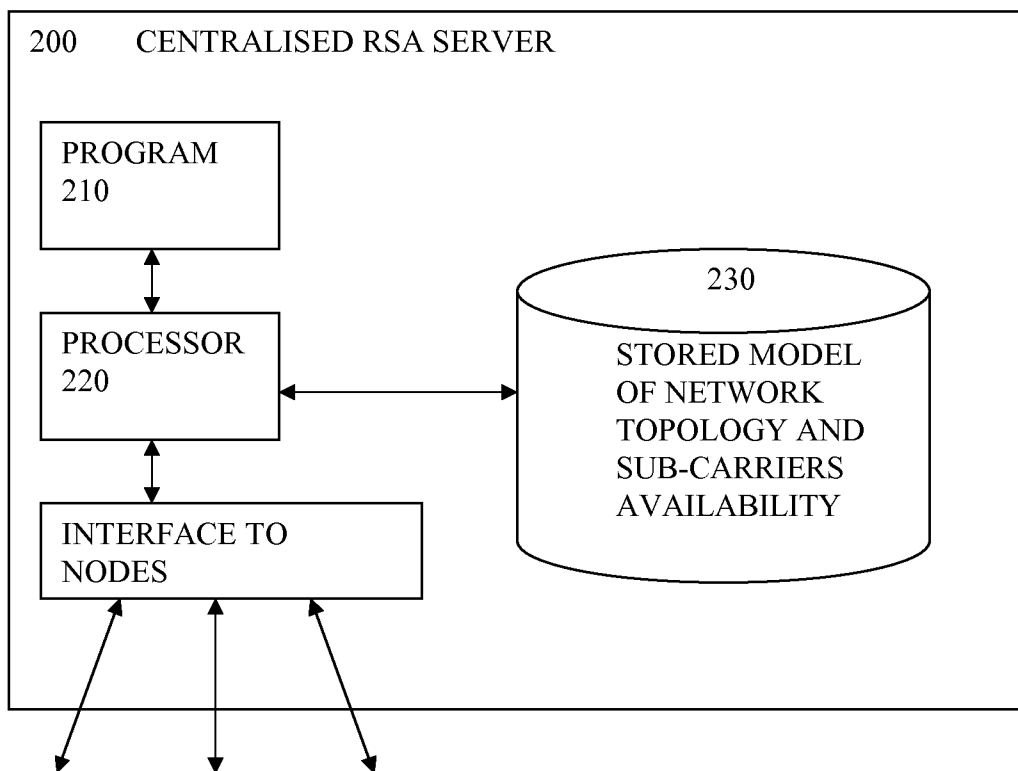

FIG 14

