

Aug. 8, 1961

B. D'ANKA  
TRAY SUPPORT

2,995,257

Filed Dec. 10, 1958

2 Sheets-Sheet 1

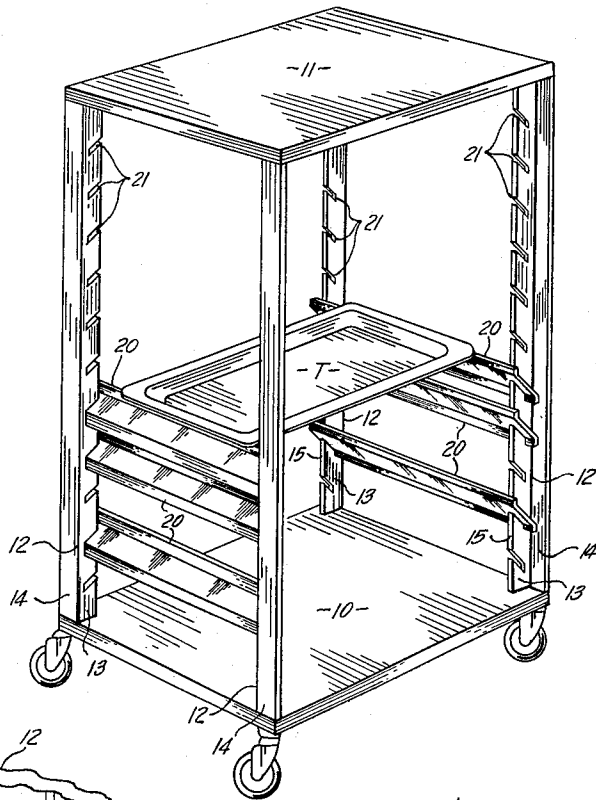

Fig 1

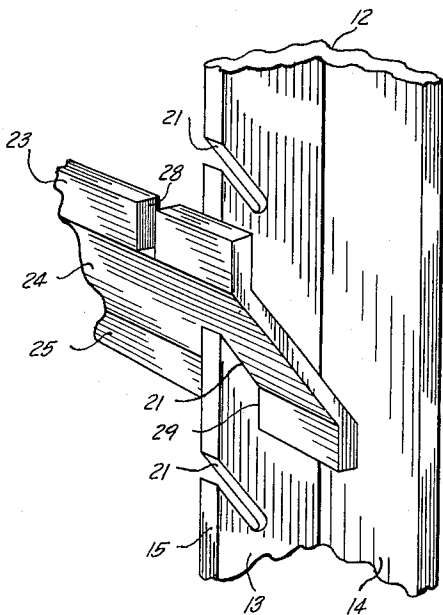

Fig 2

BLAISE D'ANKA INVENTOR.

BY BOSWORTH, SESSIONS,  
HERRSTORM & KNOWLES  
ATTORNEYS

Aug. 8, 1961

B. D'ANKA  
TRAY SUPPORT

2,995,257

Filed Dec. 10, 1958

2 Sheets-Sheet 2

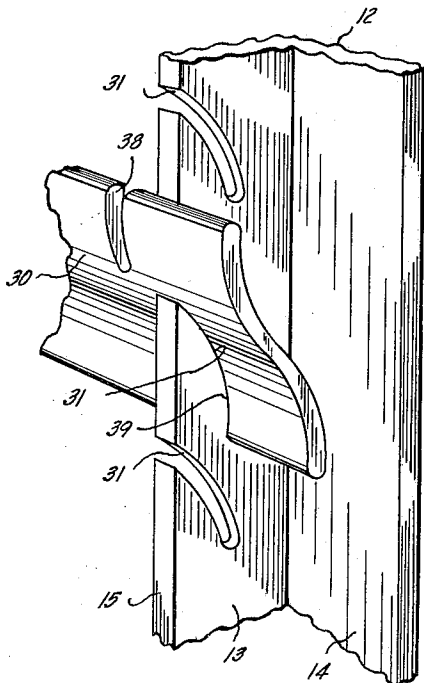

Fig 3

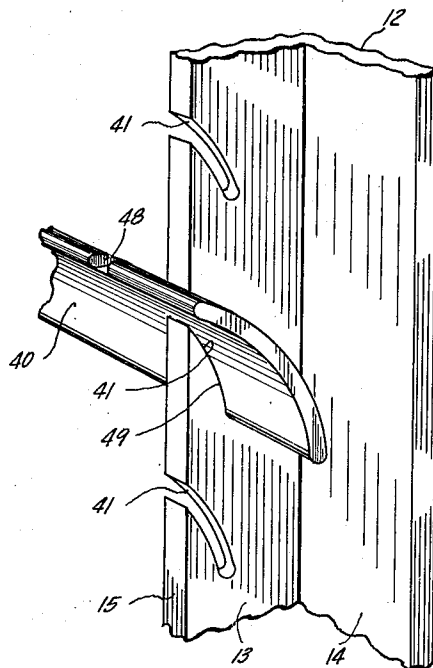

Fig 4

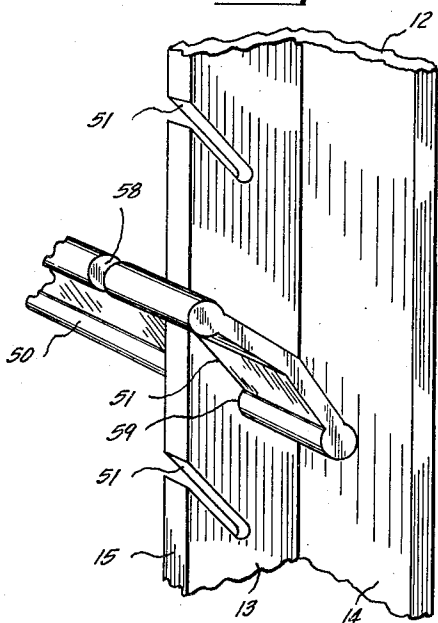

Fig 5

BLAISE D'ANKA INVENTOR.

BY BOSWORTH, SESSIONS,  
HERRSTROM & KNOWLES  
ATTORNEYS

1

2,995,257

TRAY SUPPORT

Blaise D'Anka, Cleveland, Ohio, assignor to Crescent Metal Products, Inc., Cleveland, Ohio, a corporation of Ohio

Filed Dec. 10, 1958, Ser. No. 779,434  
4 Claims. (Cl. 211-147)

My invention relates to racks for supporting and carrying a plurality of trays or the like in a horizontal position and a vertically spaced apart relation, and more particularly to a rack having improved adjustable tray supports or rails.

Racks such as those of my invention may be used for supporting and carrying trays, pans, boxes and baskets. The trays, pans, etc. may be made of plastic, wood, metal or other materials. The racks are useful in any application where trays, pans, etc. are to be held in a multiple method. Racks such as those of my invention are commonly employed, for example, in the baked goods industry for holding trays of baked goods in bakeries, on distribution trucks or at points of retail sale. Such racks may have wheels on the bottom for mobility, or they may be made without wheels as stationary racks.

The trays used in these racks are generally rectangular in plan outline and may have raised sides of varying heights ending in an outwardly extending flange or rolled edge. When in place in the rack, the trays are supported under the edge or flange of two opposite sides by rails or supports embodied in the rack. Such trays when loaded should be able to be easily placed in and removed from the rack through one or two of its faces.

Because the depth of the trays may vary between that of a relatively shallow cookie tray to a much deeper tote-type tray, and further because of the varying height of the articles that may be carried by these trays of varying depth, it is desirable to be able to space the trays apart at varying vertical distances within the rack so that no space is wasted and the total capacity of the rack can be utilized.

The tray supports or rails of the rack must provide a lip or edge projecting into the tray carrying space upon which the edges of the trays can rest. In addition, they must be able to adequately support the weight of a loaded tray while it is being placed into or removed from the rack as by sliding opposite edges of the tray along the rails or supports from one end to the other, as well as while the tray is resting in the rack in the carrying position.

A further important requirement of racks of this type is that the tray supports or rails have and maintain a relative alignment with the rack and each other so that the trays are supported in a parallel level attitude assuming the rack to be on a level surface. This is especially important if containers of liquid or semi-liquid material are carried on the trays.

It is also desirable that the rack be as simple and light as possible while affording adequate rigidity and strength for supporting its load.

Therefore, an object of my invention is to provide a rack for carrying and supporting trays as described above having tray supports or rails that can be placed at various levels on two opposite sides of the rack to achieve the various vertical spacing desired between the trays to be supported.

Another object of my invention is to provide a rack having a tray support or rail quickly and easily removable from and replaceable in such rack for convenient adjustment of the distance between the trays supported.

Still another object of my invention is to provide a rack having a tray support or rail that has sufficient beam

2

strength when supported at both ends to carry loaded trays.

Another object of my invention is to provide a rack of the type described that will support the trays in a parallel level attitude when the rack is on a level surface.

Yet another object of my invention is to provide rails or supports that are readily and easily removable from the rack while fitting snugly enough therein that an ordinary amount of jiggling and bumping encountered when wheeling or moving an empty rack about will not displace them from their parallel level alignment.

A further object of my invention is to provide a tray support or rail which adds to the rigidity and structural strength of the rack.

Still a further object of my invention is to provide a rack having a tray support or rail that will interchangeably fit any and all positions of vertical distance adjustment within the rack.

An additional object of my invention is to provide a serviceable lightweight rack having simple and sturdy removable tray supports or rails which will contribute to economies in manufacturing and operating the rack.

The way in which I accomplish the foregoing objects can be best illustrated by the following description together with the accompanying drawings of a preferred embodiment of my invention.

FIGURE 1 is a perspective view of a preferred form of a rack of my invention having improved removable tray supports showing a tray in place.

FIGURE 2 is a perspective view of a portion of the rail or support in interlocking engagement with the upright member of the rack in the preferred embodiment of my invention showing in an enlarged scale the details of said rail or support and receiving slots in the upright member.

FIGURE 3 is a perspective view of a portion of the rail or support in interlocking engagement with the upright member of the rack in a modified form of my invention in an enlarged scale in which the rail has a compound curve transverse cross section and the upright member has cooperatively shaped receiving slots.

FIGURE 4 is a perspective view of a portion of the rail or support in interlocking engagement with the upright member of the rack in another modified form of my invention in an enlarged scale in which the rail has a simple curve transverse cross section and the upright member has cooperatively shaped receiving slots.

FIGURE 5 is a perspective view of a portion of the rail or support in interlocking engagement with the upright member of the rack in still another modified form of my invention in an enlarged scale in which the rail has beaded longitudinal edges and an angled transverse cross section and the upright has suitable receiving slots.

A preferred form of the rack of my invention, as shown in FIGURE 1, consists simply of a base 10, a top 11, and four upright members 12. The base 10 and top 11 are rectangular in shape and slightly larger than the trays T to be placed within the rack. Upright members 12 are located at the corners of the base 10 and top 11 and hold them in a parallel and spaced apart relation. The base 10, top 11 and upright members 12 together form an integral self-supporting structure which constitutes the frame of the rack. Though I have shown the frame of the rack of my invention as an open structure, it is understood that the structure may have a closed side or sides, fixed or hinged to provide a door, for example. Uprights 12 are preferably members of uniform and L-shaped transverse cross section, though other shapes can be used.

Supports or rails 20 for trays are removably mounted, in a manner to be described, on two inside opposite faces of the rack. These removable supports or rails 20, sup-

ported at each end of an upright member 12, are used in pairs to support a single rectangular tray T or the like. In use, trays T are placed in the rack by placing the underside of the outwardly extending flange F along two opposite edges of the tray on two horizontally aligned parallel supports 20.

FIGURE 2 shows the manner of mounting removable supports 20 on uprights 12 in the form of the rack and supports I prefer. As seen in FIGURE 1, the upright members 12 of the angle cross section I prefer are arranged in cooperating pairs so that angle sides 14 of one cooperating pair of uprights 12 lie along one side of base 10 and corresponding side of top 11 while angle sides 14 of the other pair of uprights 12 lie along the opposite side of base 10 and top 11. In addition, the upright members 12 are preferably so arranged that the angles 14 extend toward their adjacent corners of base 10 and top 11. Thus, the angle sides 13 of each cooperating pair of upright members 12 will be parallel to each other, be located inwardly from their adjacent front or back side of bottom 10 and top 11, as the case may be, and also project inwardly from and normal to their adjacent side edge of bottom 10 and top 11. This arrangement results in an advantage that will be explained below.

The angle side 13 of each of the upright members 12 is provided with a plurality of receiving slots 21 spaced apart along its length from one end to the other. Each receiving slot 21 has an open end at the free edge 15 of angle 13 and from there is inclined downwardly and outwardly with respect to the tray carrying space of the rack. The receiving slots 21 are spaced so that a slot 21 at a particular level in one upright member 12 is in horizontal alignment with other slots 21 in the other upright members 12. Thus, a support or rail 20 such as will be described below can be horizontally supported between two cooperating upright members 12 by engagement of its two ends in a pair of horizontally aligned receiving slots 21. Another support or rail 20 similar to the first can be horizontally supported between the other two cooperating upright members 12 in the same manner and at the same level as the first. The result is two parallel rails 20 adapted to support in a horizontal plane a rectangular tray placed thereon by a pair of its opposite parallel edges.

The form of support or rail 20 I prefer in order to accomplish the objects of my invention is that shown in FIGURE 2. The rail 20, formed of a transversely angled length of extruded aluminum or the like, has what may be called a "modified Z" transverse cross section comprised of two parallel edge portions 23 and 25 and a central portion 24. Edge portions 23 and 25 meet center portion 24 at an angle which is substantially the same as the angle at which receiving slots 21 are inclined to vertical uprights 12. This can be clearly seen in FIGURE 2. Otherwise the support or rail 20 is a longitudinal member of uniform transverse cross section, long enough to horizontally bridge the distance between its two supporting uprights 12 and extend a small distance beyond each of them.

At a point near each end of rail 20 in edge portions 23 and 25, respectively, and spaced apart a distance equal to the horizontal spacing of the angles 13 of each cooperating pair of upright members 12, there are provided two open-ended slots 28 and 29. Each of slots 28 and 29 are open at a free edge of the rail 20 and extend perpendicularly inwardly therefrom to the central portion 24 of the rail 20. The slots 28 and 29 have parallel side walls spaced apart a sufficient distance to snugly engage angles 13 of uprights 12.

The rails 20, with slots 28 and 29 and upright members 12 with receiving slots 21, all as have been described above, can thus be engaged in an interlocking relationship thusly: central portion 24 adjacent slot 29 of rail 20, for example, slides within a receiving slot 21 of an upright member 12 while a portion of angle 13 of upright 12 adjacent slot 21 slides within slot 29, for example.

In connection with this interlocking relationship, I prefer that the slots 28 and 29 of rails 20 snugly receive angle sides 13 of upright members 12 and that slots 21 of upright members 12 snugly receive central portions 24 of rails 20. Such a snug interlocking fit will act to keep unloaded rails 20 in place in their prescribed horizontal parallel alignment when a mobile rack, for instance, is wheeled over bumpy surfaces. Such a fit prevents undesirable jiggling and rattling and insures that the rack 20 will be solidly and firmly seated for ready and safe receipt of trays.

The above advantages of a snug fit can be obtained without detracting from the easy and ready removability of the rails 20 by appropriate dimensioning of the interlocking parts. One method I prefer to provide this snugly fitting relationship in the preferred embodiment of my invention is to knurl or ridge one or both of the surfaces of that part of central portion 24 engaged by receiving slot 21. Such ridging is parallel to the longitude of rail 20 to increase the friction between the interlocked rails 20 and upright members 12. The rails 20 can be removed from the rack by a slight blow or tug and replaced as easily while remaining snugly seated and undisturbed by ordinary vibrations and bumping.

Further in connection with the interlocking relationship of the rails 20, upright members 12 and receiving slots 21, it will be noted that the preferred orientation of the upright members 12 with respect to base 10 as described above prevents the ends of rails 20 outward of slots 28 and 29 from projecting beyond the main body or outline of the rack. As I prefer to arrange the upright members 12, angle sides 14 provide a continuous vertical facing piece on all corners of the rack beyond which the rail ends do not project. This arrangement effectively prevents troublesome engagements by the ends of rails 20 with clothing or other adjacent racks.

Rail 20 in place between and its ends interlocked with a pair of cooperating uprights 12 has beam strength or stiffness to resist deflection under load in a vertical downward direction by virtue of the vertically aligned edge portions 23 and 25 of its transverse cross section. Further advantage is obtained from a rail or support 20 when in place in the rack of my invention as shown in FIGURE 2 because the vertical sides of slots 29 in end portion 25 bear against opposite sides of angles 13 of upright members 12 constraining them to remain parallel to each other and normal to the support. This interaction, together with the beam strength or stiffness of such rails 20, progressively contributes to the rigidity of the rack frame as each rail 20 is placed in interlocking engagement therein. Thus, as the number of trays to be supported increases, more rails are added to the frame making it increasingly rigid. This feature of my invention is important because it makes possible an efficient and functional structure which has a strength commensurate with its burden.

It will be noted that the preferred form of rail 20 has a transverse cross-sectional configuration that makes it universal in use in any particular rack. Thus, any rail, so formed, will fit any pair of horizontally aligned slots 21 in either cooperating pair of vertical uprights 12 in the rack. This universal character of the rails 20 contributes to the utility of the rack of my invention and to the ease and economy of its operation because the user of the rack need not waste time selecting a left-handed or right-handed rail for use in a particular side of the rack, nor determining any particular endedness of the rail before inserting it into a cooperating pair of slots 21 of uprights 12.

In operation, a pair of rails or supports 20 are placed in cooperating horizontally aligned slots 21 in the upright members 12 at that level at which it is desired to support a tray. Any two supports 20 may be used from a group of identical supports because of the universal character of their form and use in the rack. The sup-

5

ports snugly interlock with the vertical members 12 and can be seated with a light blow of the hand if necessary. When the rails 20 are in place, the tray T is placed in the rack by resting the forward portion of two opposite edges of the tray T on one end of the rails or supports 20 and sliding the tray T along them into place within the rack. Though the tray rails or supports 20 are supported only at their ends, they have sufficient beam stiffness to vertically downwardly directed forces to allow the weight of the loaded tray T to be slidably transferred along the span of the support.

Additional pairs of rails or supports 20 can be likewise placed in the rack for carrying more trays spaced an optimum distance apart. Each additional pair of supports placed in the rack adds to its rigidity because of the interlocking relationship and form of the supports 20 and vertical members 12 so that the rigidity and strength of the rack increases with the load placed in it.

As the rack is unloaded and reloaded, the supports 20 are removed and replaced in the positions desired. Thus, only as many tray supporting rails as needed are used at a given time.

A modified form of the preferred embodiment of my invention is shown in FIGURE 3. Rail 30 has compound arcuate or concave-convex uniform transverse cross section and is of sufficient length to horizontally bridge the distance between two cooperating upright members 12. The radius of each of the compound curves of the transverse cross section is preferably the same in order to achieve the greatest universality in the use of the rails 30 in the rack. Two open-ended slots 38 and 39 are located near each end of rail 30 so that the distance between corresponding slots at either end of the rail 30 is equal to the horizontal spacing of the angles 13 of each cooperating pair of upright members 12. Each of slots 38 and 39 are open at a free longitudinal edge of rail 30 and extend inwardly therefrom approximately one-quarter the transverse dimension, for example, of rail 30. The side walls of slots 38 and 39 are parallel and spaced apart a sufficient distance to effect a snug fit with angles 13 of vertical uprights 12.

Cooperating slots 31 are formed in angles 13 of upright members 12 for engagement by and with rails 30. The slots 31 are disposed along the angles 13 of vertical uprights 12 in the same manner as described in connection with slots 21 illustrated in FIGURE 2. Open-ended and arcuate in shape, slots 31 extend downwardly and away from their open end at the free edge 15 of angle 13. I prefer the radius of the arc of slots 31 to be slightly greater than the radii of the transverse cross section of the rails 30 to be received by slots 31 in order to hold the rails removably and snugly in the slots. The side walls of slots 31 are uniformly spaced apart a sufficient distance to receive rails 30 in interlocking engagement in the same manner as rails 20 fit slots 21 of the preferred form. That portion of rail 30 received by the slots 31 may be knurled or ridged as described in connection with rails 20 of the preferred embodiment.

I prefer to orient the arcuate slots 31 used in this embodiment so that the upper and lower side walls formed by slots 31 in angles 13 are concave and convex, respectively. Such an arrangement of slots 31 tends to vertically align the transverse cross section of supports 30 to achieve the greatest stiffness of support 30 with respect to vertically directed forces; i.e., the weight to be supported. In addition, the side walls of slots 38 or 39 bear against angles 13 of upright member 12 in more or less vertical line of bearing with this arrangement of slots 31 which tends to increase the contribution of each rail or support 30 to the stiffness of the rack.

Another modified form of my improved tray support for racks is shown in FIGURE 4. The rail or support 40 in this form has a simple curve or arcuate uniform transverse cross section and is provided with open-ended transversely extending slots 48 and 49 near each end.

6

Slots 48 and 49, open at opposite longitudinal edges, respectively, of the support 40, each extend inwardly and transversely of the support 40 one-quarter of the transverse dimension, for example, of the support 40.

The distance between the two slots 48 opening on one longitudinal edge and the two slots 49 on the other edge is such that the slots 48 or 49 can be interlocked with a cooperating pair of slots 41 as described in connection with the other forms of my invention. Slots 41 in form and location are like slots 31 in the embodiment illustrated in FIGURE 3. I prefer that the radius of the arc of slots 41 be slightly greater than the radius of the arc of the transverse cross section of rails 40 to be received by slots 41 so that the rails are removably and snugly held in the slots.

The form of rail or support of my invention shown in FIGURE 4 also has a high beam stiffness to vertically directed forces while at the same time contributing to the rigidity of the rack in which it is used because of the substantially vertical line of bearing between the interlocked slots 48 or 49 of the rail 40 and angles 13 of vertical members 12.

The modified forms of the rack for tray supports or rails of my invention as illustrated in FIGURES 3 and 4 operate substantially the same way as does the preferred embodiment of my invention described above and provide similar structural and operational advantages.

FIGURE 5 shows still another modified form of the rack of my invention in which the supports or rails 50 have edge portions 53 and 55 of circular transverse cross section joined together by a central portion 54 having an angled transverse cross section. The entire transverse cross section of the rail 50 can be described as an "angled dog bone." Rail 50 is provided with transverse slots 58 and 59 near each of its ends which extend inwardly from their respectively associated longitudinal edge of rail 50 and are disposed along rail 50 in the same manner at the transversely extending slots 28 and 29 of rail 20 of the preferred embodiment of my invention.

Receiving slots 51, vertically spaced up and down the length of angled sides 13 of uprights 12 in the same manner as the receiving slots in the preferred embodiment of my invention, are inclined downwardly and outwardly with respect to the tray carrying space within the rack having an open end along the free edges 15 of angled sides 13.

Rails 50 are supported by and interlockingly engaged with a cooperating pair of upright members 12 in the same manner as the other forms of my invention described above. The circular cross section edge portions 53 and 55 of rail 50 provided the necessary beam stiffness to vertically downwardly directed forces along the span of the rail 50, as well as provide an enlarged area of engagement between the side walls of slots 58 or 59, as the case may be, and angled sides 13. In addition, the edge portions 53 and 55 of circular transverse cross section furnish a most satisfactory longitudinally extending and transversely rounded edge for sliding trays onto and from the rails or supports of the rack of my invention.

The form of my invention illustrated in FIGURE 5 operates and functions in a similar manner to the other forms of my invention herein described and possesses all of the structural and operational advantages embodied in those forms in addition to providing a rail having an edge easily and smoothly slidably engageable by trays used in the rack.

Changes, modifications and improvements may be made to the above-described preferred and modified forms of my invention without departing from the precepts and principles of the invention. Therefore, I do not wish my patent to be limited to any particular form of my invention specifically illustrated and described nor in any manner inconsistent with the extent to which my invention has promoted the art.

I claim:

1. A rack for supporting trays at adjustable levels com-

prising plural upright members, means for supporting said upright members in upright spaced generally parallel relation on opposite sides of the rack, there being at least two upright members on each of said sides, the respective upright members on each side of the rack having exposed longitudinally-extending edge portions facing upright members on the other side of the rack, the exposed edges of the upright members each being provided with rail-receiving slots extending downwardly into the body of the respective upright members at an angle and opening out through the respective exposed edges at points lying substantially in a common plane, elongated tray supporting rail members each having plural transverse slots along a longitudinally-extending edge thereof and opening out through the respective longitudinal edges at points spaced therealong a distance corresponding to the spacing between the upright members on the respective opposite sides of the rack, the slotted longitudinal edge portions of the respective rail members being dimensioned for reception within the slots of the upright members, with the walls which define the slots in the longitudinal edge portions of the rail members lying on opposite sides of and in snug contact with the slotted edges of the upright members, said rail members each having a cross section of substantially uniform configuration throughout the length thereof and having opposite longitudinally extending edge portions at least one of which is offset laterally from the general plane of the rail member in a direction such that when the rail members are mounted on the upright members with the respective slotted edge portions thereof engaged, the longitudinal edges of the respective rail members opposite that edge which is engaged with the upright members will lie in laterally spaced relation to the respective adjacent exposed edges of the associated upright members.

2. The rack described in claim 1 wherein the longitudinally-extending edge portions of the rail members are offset in opposite directions with respect to the general plane of the central portion of the rail members.

3. The rack described in claim 1 wherein the slots provided in the exposed edges of the upright members are arcuate in form and extend into the body of the upright members in a direction downwardly and away from the open end of the slot, and wherein the rail members have a curved transverse cross section which disposes the longitudinally-extending edge portions of the rail in planes offset laterally from the plane of the central portion thereof.

4. The rack described in claim 1 wherein the longitudinally-extending edge portions of the rail members are bent towards each other about a line extending longitudinally of the rail members to provide a transversely angled cross section, and wherein each longitudinally-extending edge of the rail is thickened to provide in cross section a generally circular embossment extending longitudinally throughout the length of the rail.

#### References Cited in the file of this patent

##### UNITED STATES PATENTS

450,289	Gottfried	Apr. 14, 1891
874,315	Eno	Dec. 17, 1907
1,273,397	Neill	July 23, 1918
2,820,552	Erisalau	Jan. 21, 1958

##### FOREIGN PATENTS

80,349	Norway	of 1952
130,177	Germany	of 1902
136,490	Sweden	of 1952
309,063	Sweden	of 1955
375,504	Great Britain	of 1932