



INTERNATIONAL APPLICATION PUBLISHED UNDER THE PATENT COOPERATION TREATY (PCT)

<p>(51) International Patent Classification ⁶ : H01R 13/629</p>	<p>A1</p>	<p>(11) International Publication Number: WO 96/32761 (43) International Publication Date: 17 October 1996 (17.10.96)</p>
<p>(21) International Application Number: PCT/IB96/00314 (22) International Filing Date: 10 April 1996 (10.04.96) (30) Priority Data: 9507627.9 12 April 1995 (12.04.95) GB 9507628.7 12 April 1995 (12.04.95) GB (71) Applicant (for all designated States except US): THE WHITAKER CORPORATION [US/US]; Suite 450, 4550 New Linden Hill Road, Wilmington, DE 19808 (US). (72) Inventors; and (75) Inventors/Applicants (for US only): CANUTO, Oscare [IT/IT]; Via Rossini, 62, I-10093 Collegno (IT). MASSOLA, Paolo [IT/IT]; C,so Dora, 15, I-10051 Avigliana (IT). (74) Agents: NINA, Driscoll, A. et al.; AMP International Enterprises Ltd., AMPèrestrasse 3, CH-9323 Steinach (CH).</p>		<p>(81) Designated States: BR, CN, JP, KR, PL, TR, US, European patent (AT, BE, CH, DE, DK, ES, FI, FR, GB, GR, IE, IT, LU, MC, NL, PT, SE). Published With international search report.</p>

(54) Title: MODULAR ELECTRICAL CONNECTING UNIT

(57) Abstract

The modular unit (2) comprises a frame (4), and a lever (6) for driving camming slides (8) to mate plug connectors (148) with socket connectors (150). The frame (4) is divided into a series of compartments (18) each for receiving one plug connector (148) and one socket connector (150) and each slide has camming slots (82) each associated with one of the compartments (18) to receive a trunnion (162) on a short end face (160) of a respective plug connector (148).

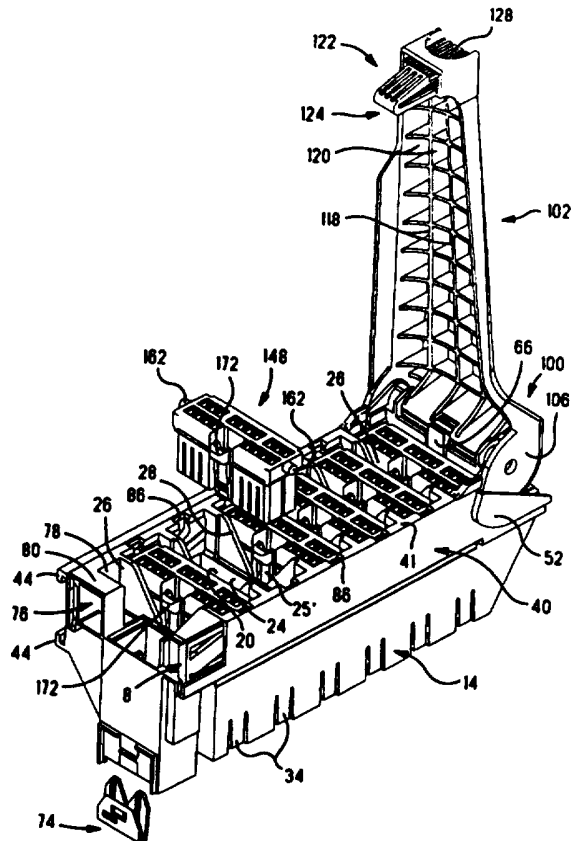

FOR THE PURPOSES OF INFORMATION ONLY

Codes used to identify States party to the PCT on the front pages of pamphlets publishing international applications under the PCT.

AM	Armenia	GB	United Kingdom	MW	Malawi
AT	Austria	GE	Georgia	MX	Mexico
AU	Australia	GN	Guinea	NE	Niger
BB	Barbados	GR	Greece	NL	Netherlands
BE	Belgium	HU	Hungary	NO	Norway
BF	Burkina Faso	IE	Ireland	NZ	New Zealand
BG	Bulgaria	IT	Italy	PL	Poland
BJ	Benin	JP	Japan	PT	Portugal
BR	Brazil	KE	Kenya	RO	Romania
BY	Belarus	KG	Kyrgyzstan	RU	Russian Federation
CA	Canada	KP	Democratic People's Republic of Korea	SD	Sudan
CF	Central African Republic	KR	Republic of Korea	SE	Sweden
CG	Congo	KZ	Kazakhstan	SG	Singapore
CH	Switzerland	LI	Liechtenstein	SI	Slovenia
CI	Côte d'Ivoire	LR	Liberia	SK	Slovakia
CM	Cameroon	LK	Sri Lanka	SN	Senegal
CN	China	LT	Lithuania	SZ	Swaziland
CS	Czechoslovakia	LU	Luxembourg	TD	Chad
CZ	Czech Republic	LV	Latvia	TG	Togo
DE	Germany	MC	Monaco	TJ	Tajikistan
DK	Denmark	MD	Republic of Moldova	TT	Trinidad and Tobago
EE	Estonia	MG	Madagascar	UA	Ukraine
ES	Spain	ML	Mali	UG	Uganda
FI	Finland	MN	Mongolia	US	United States of America
FR	France	MR	Mauritania	UZ	Uzbekistan
GA	Gabon			VN	Viet Nam

MODULAR ELECTRICAL CONNECTING UNIT

This invention relates to a modular electrical connecting unit, in particular for use as a central
5 connecting unit in the automotive industry.

There is disclosed in EP-A-O 363 804 an electrical connecting unit comprising an elongate frame for receiving
matable electrical connectors, a pair or slides slidable
lengthwise of the frame along opposed elongate side walls
10 of the frame, the slides having camming surfaces for
engagement by projections on a first connector, and an
actuating lever connected to the frame and the slides for
movement from an open to a closed position to drive the
slides in a first direction to mate the connectors and
15 from the closed to the open position to drive the slides
in a second and opposite direction to unmate the
connectors.

This known connecting unit contains only one pair of
mating connectors both of which extend for the full length
20 of the frame. Especially in the automotive industry the
end user of such a unit may from time to time alter from
one model to the next the number of lines, that is to say
connector positions, the end user requires the connecting
unit to provide with the result that the connecting unit
25 must be frequently redesigned.

According, therefore, to the present invention an
electrical connecting unit as defined in the second
paragraph of this specification is characterized in that
the frame is divided into a series of compartments by
30 partitions extending across the elongate frame, and in
that each slide has a series of camming surfaces each
associated with an individual one of the compartments, for
engagement by a respective projection on an individual
first connector, each compartment having means for
35 retaining an individual second connector therein, whereby
the connecting unit can be used for mating 1 to n pairs of
matable connectors where n is the number of the
compartments.

CONFIRMATION COPY

-2-

Thus the number of connector positions provided can be altered at will in order to meet the varying requirements of the end user. In the interest of versatility the number of compartments for a given frame length can be maximised by dimensioning the compartments so that they are elongate transversely of the frame, the projections being provided on short, rather than long, faces of the connectors. In one example each connector has eighteen positions.

10 Advantageously the frame may have a mounting device for securing it to a support, for example, an interconnection box, when the connection unit is in situ.

The lever may be dimensioned so that when it is in its closed position it acts as a partial cover for the compartments thereby allowing leads extending from the first connectors to extend outwardly from the connecting unit. To this end the lever may comprise a pivot portion connected to the frame and a free ended lever arm projecting from the pivot portion and being substantially narrower than the pivot portion. In this case the lever arm is preferably of honeycomb construction in the interest of strength with economy of material.

There is further disclosed in EP-A-0 363 804 the frame and lever assembly for an electrical connecting unit where the lever having a rear end pivoted to the frame for movement of the lever between an open position in which the lever is raised from the frame and a closed position in which the lever is adjacent to the frame, wherein the lever has at its forward end a latch arm having a rear portion connected to the lever and a forward portion connected to the rear portion by a bight, the forward portion having a forwardly projecting latching shoulder for engaging an abutment to latch the lever in its closed position, the latching shoulder being releasable from the abutment by pressing the forward portion of the latch arm rearwardly.

In this known assembly the frame has therein a first electrical connector and the lever is actuatable to cause a

-3-

second electrical connector to be cammed into mating relationship in the frame with the first electrical connector. The second electrical connector has a cover with a trunk for marshalling leads connected to terminals
5 of the second connector. Especially in the case of connecting units where no such cover is provided it is important that the forward portion of the latch arm should be protected against entanglement with the leads. The forward portion of the latch arm should also be protected
10 against accidental actuation, but should, nevertheless, be easily actuable.

According to the present invention, therefore, an electrical connector assembly having a frame and lever as discussed above is characterized in that the forward
15 portion of the latch arm upstands from the latching shoulder between forward side wall portions of the lever, and in that a front end wall of the lever, spanning the side wall portions, has a cut-out allowing access to the forward portion of the latch arm.

The forward portion of the latch arm is thus fully protected by the side wall portions of the lever and the front wall thereof, but the forward portion of the latch arm is readily actuable by finger pressure by way of the cut-out. In order to facilitate such actuation a free end
20 of the forward portion preferably extends to a position substantially level with a top wall of the lever, the cut-out also extending to that level. Also preferably, the latch arm is formed with reinforcing corrugations and the forward portion of the latch arm is stiffly resiliently
25 deflectable about the bight.

Means are preferably provided for releasably retaining the lever in its open position, as well as means for accurately guiding the lever between its open and its closed positions.

The connectors will normally be colour coded so that
35 polarizing means should be provided to ensure that the compartments can receive connectors of the correct colour code.

As disclosed herein, means are provided for retaining the first connectors in a pre-mating position in the compartments, the retaining means being overcome when the slides' camming surfaces acting on the projections of the first connectors, force them into the second connectors.

US-A-5 178 553 discloses a lever operated connector assembly in which a row of rigidly connected plug connectors are mated with respective socket connectors. An actuating lever has camming surfaces engaged by projections on the socket connectors to draw them into the plug connectors.

An embodiment of the present invention will now be described by way of example with reference to the accompanying drawings in which;

Figure 1 is a longitudinal sectional view of a modular central electrical connecting unit comprising a frame for receiving multi contact plug and socket electrical connectors and a lever on the frame for driving camming slides to mate the plug connectors with the socket connectors;

Figure 2 is an isometric view of the connecting unit with the lever in an open position and with parts exploded from the frame;

Figure 3 is an isometric view of the connecting unit with the lever in a closed position;

Figures 4 and 5 are respective exploded isometric views of the connecting unit, the connectors not being shown;

Figure 6 is an enlarged, fragmentary, isometric view showing means for releasably retaining the lever in its open position.

Figure 7 is a sectional view through the axis of the lever and illustrating details of Figure 6;

Figure 8 is an enlarged, fragmentary, isometric view of a forward end portion of the lever showing a latch for latching the lever in its closed position.

Figure 9 is a longitudinal sectional view illustrating details of Figure 8;

Figure 10 is a fragmentary top plan view showing details of Figures 8 and 9;

Figure 11 is a fragmentary side view illustrating further details of Figures 8 to 10;

5 Figure 12 is an enlarged isometric view of one of the plug connectors;

Figure 13 is a transverse partly sectional view illustrating a connector of Figure 12 located in a pre-mating position in a mating connector;

10 Figure 14 is an enlarged, fragmentary view illustrating details of Figure 13;

Figure 15 is a similar view to that of Figure 1 but is differently sectioned and shows terminals of the plug and socket connectors;

15 Figure 16 is an enlarged fragmentary view illustrating details of Figure 15;

Figure 17 is a top plan view showing the connecting unit assembled to an interconnecting box;

20 Figure 18 is a cross sectional view showing the connecting unit in situ and assembled to the interconnecting box;

Figure 19 is an enlarged isometric view of the interconnecting box;

Figure 20 is a plan view of a socket connector;

25 Figure 21 is an underplan view of the frame; and

Figure 22 is a plan view of a plug connector.

As shown in Figures 1 to 5 modular central electrical connecting unit 2 comprises a connector receiving frame 4, an actuating lever 6 and camming slides 8, each moulded
30 from an insulating material. The frame 4, which is elongate and is of generally rectangular shape has a forward end wall 10, a rear end wall 12 and elongate side walls 14. Spanning the side walls 14 are spaced, transverse partitions 16, defining in the present example,
35 a row of six connector receiving compartments 18 each having an upper open end 20 and a lower open end 22. There projects upwardly from the upper edge 24 of each partition 16, two connector guide wings 26 spaced

-6-

transversely of the length of the frame 4, and each having inclined surfaces 28 sloping downwardly to the upper edge 24 to define a V-shaped opening 25'. The lower margin of each side wall 14 of the frame 4 is formed with downwardly directed latch arms 34 each having a latching barb 36 directed inwardly of a respective one of the compartments 18. The upper margin of each side wall 14 is formed with a longitudinally extending slide way 40 receiving a respective one of the camming slides 8 between upper and lower gibs 41 and 43, respectively (Figures 16 and 18). The inner side of each slide way 40 opens into each compartment 18 between the gibs 41 and 43. The lower edge of each side way 40 is substantially level with the upper edges 24 of the partitions 16. The outer wall of the slide way 40 on one side of the frame 4 is formed with a mounting device 43 comprising an outwardly open channel 42 defined by said outer wall and upper and lower gibs 44 extending longitudinally of the frame 4. As best seen in Figure 4, said outer wall is formed at the rear end of the channel 42 with a rearwardly directed latch arm 46 having a rearwardly facing latching shoulder 48 from which extends rearwardly cam follower tip portion 50. The outer wall of each slide way 40 is formed at the rear end thereof with a lever guide rail 52 which is stood off outwardly from the remainder of said outer wall. Immediately above the guide rail 52 there upstands from each side wall 14 a bifurcated lug 54 defining aligned bearing holes 56. The lugs 54 are spanned by cruciform reinforcing struts 58 as shown in Figure 4. The side walls 14 are spanned rearwardly of the frame 4 by a platform 60 which aids in supporting the flanges 54. Rearward reinforcing struts 62 are formed integrally with the end wall 12 of the frame 4 and the under side of the platform 60. As best seen in Figure 6, there upstands from the base of a notch 64 in the upper margin of the rearmost partition 16, a lever open position latch arm 66 having a rearwardly directed latching nose 68. At one side of the forward end part of the frame 4 is a housing

-7-

70 having cavities 72 each for latchingly receiving a respective male power terminal 73. A secondary locking clip 74 is provided for ensuring that the terminals 73 are secured in the cavities 72 against the action of vibration. On the other side of the forward end part of the frame 4 and located above the housing 70 is a lever latch receptacle 76 having a lever latch receiving socket 78 and a lever latching abutment in the form of a top wall 80.

Each camming slide 8 comprises an elongate, substantially flat, plate, the inner face of which is formed with a camming slot 82 for each compartment 18 of the frame 4. The slots 82 are arranged in succession lengthwise of the slide 8. Each slot 82 has an open upper end 84, which, in a retracted, connector loading position of the slide 8 communicates with a through opening 86 in the respective upper gib 41 of the slideway 40 as best seen in Figure 16. Each slot 82 has a forwardly directed, blind, arcuate lower end 88 spaced from the gib 41 towards the gib 43. Intermediate its ends, each slot 82 has an upper section 90 which makes a first acute angle with respect to the gib 41, and a lower section 92 which makes a second acute angle with respect to the gib 41. The second angle is greater than the first, that is to say the section 90 is steeper than the section 92. Each slide 8 has, at its rear end, an elongate transverse opening 94 for providing a lost motion connection to the lever 6 as described below, and a transverse lever stop lug 96. The slots 82 are defined by depressions 98 in the outer face of the slide 8. The lugs 96 ensure that each slide 8 can only be positioned in its correct slideway 40.

The lever 6 comprises a rear pivot portion 100 from one side of which extends forwardly, a forwardly tapered lever arm 102. The portion 100 is thus substantially wider than the arm 102. The pivot portion 100 comprises a transverse tubular shaft 103 extending between the lugs 54 of the frame 4. Outside the lugs 54 are opposed cheeks 106 having aligned holes 108 therethrough. A pivot pin 104

extends through the holes 108, the holes 56 in the lugs 54 and through the tubular shaft 103. The pivot pin 104 has an enlarged end 110 engaging the outer face of one of the lugs 54. The lever 6 is thus pivotable about the pin 104.

5 Each of the cheeks 106 has an inwardly projecting boss 112 below the pin 104 and which engages in the elongate opening 94 of the respective slide 8. A lost motion connection is thereby provided between the lever 6 and each slide 8. Each cheek 106 engages slideably between a

10 respective guide rail 52 and a rearward extension of the lower gib 43 of the respective slide way 40. The tubular shaft 103 has a notch 114 therein (Figures 6 and 7) for engagement by the latching nose 68 of the latch arm 66, releasably to retain the lever 6 in a raised open position

15 with the slides 8, therefore, each in a retracted position. The lever arm 102, is, in the interest of economy of material, and at the same time in the interest of mechanical strength, of honeycomb construction. The arm 102 thus has a thin top wall 116 having on its inner

20 face, intersecting transverse and longitudinal ribs 118 and 120 respectively. The arm 106 has, at its free end, a latching device which is generally referenced 122 and which is best seen in Figures 8 to 11. The latching device 122, which is for releasably retaining the lever 6

25 in its closed position, comprises a latch arm 124 having a downwardly depending rear portion 126 formed integrally with, and extending from, the top wall 116 of the lever arm 102. The arm 124 further comprises a forward portion 128 connected to the rear portion 126 by a bight 130 about

30 which the portion 128 is stiffly resiliently deflectable. The forward portion 128 extends upwardly into a forward cavity 132 of the lever arm 102 and has a free end 134 level with the top wall 116. The cavity 132 is bounded rearwardly by the rear portion 126, laterally by forwardly

35 projecting side wall portions 136 of the level arm 102, and forwardly by a front wall 138 spanning the side wall portions 136. The front wall 138 has a cut-out 140 to allow finger access to the upper part of the forward latch

arm portion 128. The cut-out 140 has an arcuate base bowed towards the bight 130 and extends to the level of the top wall 116. Below the lever arm 102, the portion 128 of the latch arm 124 has a forward latching shoulder 142 which is engageable under the top wall 80 of the receptacle 76. The latch arm 124 does not extend across the full width of the forward end of the lever arm 102, thereby leaving a forward lower shoulder 144 of the arm 102, free to engage the top gib 41 of the adjacent slide way 40 in the closed position of the lever 6. The latch arm 124 has longitudinal reinforcing corrugations 146. The upper part of the rear portion 126 has enhanced height corrugations 147 to provide anti-overstress for the latch arm 124.

Each compartment 18 of the frame 4 is adapted to receive a plug connector 148 and a mating socket connector 150 (Figures 1, 13 and 15) having male terminals 151 secured in an insulating housing 153. As best seen in Figures 12 to 14, each plug connector 148 comprises an insulating housing 152 containing female terminals 154 (Figure 15). Each plug connector 148 has a mating face 156 and opposite thereto a terminal receiving face 157. The housing 152 has long side faces 158 and 159 and much shorter end faces 160. There projects from each end face 160, proximate to the terminal receiving face 157, a circular cylindrical projection in the form of a trunnion 162 as best seen in Figure 2, for engaging in a respective slot 82 of a respective slide 8. The side face 158 of each connector 148 has a latch arm 164 having a latching nose 166 for latching engagement under a latching lip 25 of a respective mating socket connector 150, as best seen in Figure 13, to latch the connector 148 in a pre-mating raised position to prevent its withdrawal from the frame 4. The side face 158 has at least one key way 168 for receiving a respective key 33 in the connector 150 and the side face 159 has at least one key way 170 for receiving a respective key 32 in the connector 150. The latch arm 164 is surmounted by a projecting stop 172 for engaging

-10-

the upper edge 173 of the mating connector 150, in the mating position of the connector 148. The stop 172 can be pressed to deflect the latch arm 164 to allow the connector 148 to be removed from the frame 4. As shown in Figure 1, each connector 148 is loaded into its respective compartment 18 in the direction of the arrow B after the female terminals 154 of the connector 148 have been terminated to insulated leads L. The socket connectors 150 (Figures 1, 13 and 15) are loaded into their respective compartments 18 after the male terminals 151 have been terminated to leads L2. The barbs 36 of the latch arms 34 snap behind the housings 153 of the connectors 150 thereby latching them in their compartments 18. The power terminals 73 are latched into the cavities 72 after leads L3 have been terminated to the terminals 73 and are locked securely in their cavities by means of the secondary locking clip 74.

As shown in Figures 17 and 18, the gibs 44 and the latch arm 46 are used in securing the connecting unit 2 in situ, for example, in an automotive vehicle, by fixing the unit 2 to an interconnection box 174. As best shown in Figure 19, the box 174 comprises lugs 176 by which it is secured to a fire wall, for example. A free end face 178 of the box 174 has a longitudinal rib 180 defining in cooperation with the face 178 opposed grooves 182 opening into one end 184 of the rib 180 and terminating at stop shoulders 188 at a position just back from the other end 186 of the rib 180. The rib 180 is thus T-shaped cross section for nearly all of its length. A latch member 190 on the face 178 of the interconnection box 174 is spaced from the end 184 of the rib 80 and presents a shoulder 192 facing the end 184 of the rib 180 and an inclined cam surface 193 facing away therefrom. In order to mount the connecting unit 2 to the interconnection box 174, the forward ends of the gibs 44 of the mounting device 43 are inserted into the grooves 182 of the rib 180 until the forward ends of the gibs 44 abut the stop shoulders 188. At this time, the lip portion 50 of the latch arm 46 of

-11-

the device 43 has been cammed over the cam surface 193 of the latch member 190 so that the latching shoulder 48 of the arm 46 snaps down behind the shoulder 92 of the latch member 190.

5 In order to prepare the connecting unit 2 for use, the socket connectors 150 are loaded into the lower portions of the compartments 18 in the manner described above so as to be latched therein. The lever 6 is retained in its open position by means of the latch arm 66
10 as described above. The plug connectors 148 are loaded into the upper portions of the socket connectors 150, in their premating positions as shown in Figure 13. In the open position of the lever 6 the slides 8 are in their retracted positions so that the upper end 64 of each
15 camming slot 82 communicates with a respective opening 86 (Figure 16). During the loading of the connectors 148, their trunnions 162 enter the camming slots 82 by way of the openings 86 in the gibs 41, to lie in the upper sections 90 of the camming slots 82. In order to mate
20 each plug connector 148 with the socket connector 150 there beneath, the lever 6 is depressed into its closed position, accurately guided by the rails 52, so that the lever 6 is retained in that position by engagement of the latching shoulders 142 of the latching device 122 under
25 the top wall 80 of the receptacle 76. As the lever 6 is being swung to its closed position, the bosses 112 on the lever 6 drive the slides 8 forwardly so that the trunnions 162 are forced down the upper sections 90 of the camming slots 82 into their lower sections 92 up to the ends 88 of
30 the slots 82, whereby, each plug connector 148 is mated with the socket connector 150 therebeneath. Since the upper sections 90 of the slots 82 are relatively steep, the connectors 148 are moved rapidly towards the connectors 150 until the trunnions 162 enter the lower
35 sections 92 which are of relatively shallow gradient, so that as the required mating force increases, the mechanical advantage provided by the lever and slide system also increases. The leads L1 extending from the

-12-

connectors 148 extend upwardly from the frame 4 as shown in broken lines in Figure 18 by virtue of the fact that the lever arm 102 is substantially narrower than the width of the frame 4 thereby allowing egress space for the leads L1. The leads L2 of the connectors 150 extend from the bottom of the frame 4. The plug connectors 148 can be removed from the frame by first releasing the latching shoulder 142 of the latch arm portion 128, from the abutment top wall 80, by rearward finger pressure on the portion 128 by way of the cut-out 140 to retract the shoulder 142 rearwardly and then returning the lever 6 to its open position and pressing the stops 172 of the connectors 148 inwardly to deflect the latch arms 164 to permit the connectors 148 to be removed from the frame 4.

As the slides 8 are connected to the short end faces 160, of the connectors 148, rather than to their longer side faces 158 and 159, and as the connectors 150 extend in the same direction as the connectors 148, a maximum number of connectors can be accommodated for a given length of the frame 4.

Depending upon the end user's requirements, connectors will be provided in all of the compartments 18 or only in a stipulated number of them. The latching device 122 for latching the lever 6 in its closed position, has the particular advantage that the free end 134 of the latch arm 124 is protected by the lever 6 against tangling with the leads L1, and also against accidental actuation of the latch arm 124. By virtue of the cut-out 140 the latching device 122 is very easy to operate.

As shown in Figures 20 and 21. The connectors 150 may have side keys 200 for engaging in keyways 202 in the partitions 16 and the connectors 148 may have end keys 204 for engaging in end keyways 206 of respective connectors 150.

The connectors of all mating pairs are mated simultaneously by moving the lever 6 from its open to its closed position, whereby all circuits connected to the

-13-

leads L1 and L2 are simultaneously made. Conversely, by moving the lever 6 from its closed to its open position all the circuits are simultaneously broken.

5 Preferably all of the connectors are colour coded and the keys and keyways are so arranged that each compartment 18 can only accept connectors of a particular code colour.

10 Advantageously then an electrical connector according to the present invention provides a connector modular with the ability to receive modular connectors as required in a central location. A lever structure is provided for mechanical advantage and the lever structure includes an integrally moulded latch arm that is protected in a shroud to prevent wire tangling or inadvertent disengagement.

-14-

CLAIMS

1. An electrical connecting unit (2) comprising an elongate frame (4) for receiving first and second matable electrical connectors (148, 150), a pair of spaced slides (8) slidable lengthwise of the frame (4) along opposed elongate side walls (14) of the frame (4), the slides having camming surfaces (82) for engagement by projections (162) on the first connector (148), and an actuating lever (6) connected to the frame (4) and the slides (8) for movement from an open to a closed position to drive the slides (8) in a first direction to mate the connectors (148, 150) and from the closed to the open position to drive the slides (8) in a second and opposite direction to unmate the connectors (148, 150); characterized in that the frame (4) is divided into a series of compartments (18) by partitions (16) extending across the elongate frame (4), and in that each slide (8) has a series of camming surfaces (82) each associated with an individual one of the compartments (18), for engagement by a respective projection (162) on an individual first connector (148), each compartment having means (34, 36) for retaining an individual second connector (150) therein, whereby the connecting unit (2) can be used for mating from 1 to n pairs of matable connectors (148, 150) where n is the number of the compartments (18).

2. A connecting unit (2) as claimed in claim 1, characterized in that one or more of the compartments (18) contains said individual first and second connectors (148, 150), each of these connectors having longer side faces (158, 159) and shorter end faces (160), the projections (162) of the first connector (148) being on the shorter end faces (160) thereof, the compartments being elongate transversely of the frame (4).

3. A connecting unit (2) as claimed in claim 1 or 2, characterized in that one side wall (14) of the frame (4)

is provided with a mounting device (43) for securing the frame (4) to a support (174), the mounting device comprising a slideway (40) presenting an outwardly facing channel (42) defined by gibs (44) extending lengthwise of the frame, and a latch arm (46) on said side wall (14), the latch arm (46) being spaced from, and aligned with, one end of the channel (42) and having a shoulder (48) facing away from said one end, and a lip portion (50) extending from the shoulder (48) in a direction away from said one end of the channel (42).

4. A connecting unit as claimed in claim 1, 2 or 3, characterized in that the lever (6) comprises a pivot portion (100) at one end of the frame (4) and a free ended lever arm (102) extending from the pivot portion (100) and being substantially narrower than the pivot portion in the transverse direction of the frame (4), the lever arm (102) covering, in the closed position of the lever (6), only part of each compartment (18) for allowing leads (L1) extending from the, or each, first connector (148) to escape from the connecting unit (2).

5. A connecting unit (2) as claimed in claim 4, characterized in that the lever arm (102) is of honey comb construction in that it comprises an upper longitudinal thin wall (116) an intersecting transverse and longitudinal ribs (118, 120) on the inner face of said thin wall (116).

6. A connecting unit (2) as claimed in any one of the preceding claims, characterized in that a latch arm (66) on the frame (4) is engageable in an opening (114) in a journal shaft of the lever (6) for releasably latching the lever (6) in its open position.

7. A connecting unit (2) as claimed in any one of the preceding claims, characterized in that a lever guide rail (52) upstands from each side wall (14) of the frame (4),

-16-

opposed cheeks (106) on the lever (6) each slidably engaging a respective one of the guide rails (52) to guide the lever (6) between its open and its closed positions.

- 5 8. A connecting unit (2) as claimed in any one of the preceding claims, characterized by keying means for ensuring that only predetermined connectors can be received in each compartment.
- 10 9. A connecting unit (2) as claimed in any one of the preceding claims, characterized in that each second connector (150) has a latching lip (25) for engaging a latching nose (88) of a respective first connector (148) to retain it in a raised pre-mating position.
- 15 10. A connecting unit as claimed in any one of the preceding claims, characterized in that each compartment (18) has an upper open end (20) for receiving a respective first connector (148) and a lower open end (22) for receiving a respective second connector (150), and a latch arm (34) having a latching barb (36) proximate to said lower end (22) for retaining the second connector (150) in the compartment (18).
- 20 11. A frame and lever assembly for an electrical connecting unit (2), the lever (6) having a rear end (100) pivoted to the frame for movement of the lever between an open position in which the lever (6) is raised from the frame (4) and a closed position in which the lever (6) is adjacent to the frame (4), wherein the lever (6) has at its forward end a latch arm (124) having a rear portion (126) connected to the lever (6) and a forward portion (128) connected to the rear portion (126) by a bight (130), the forward portion (128) having a forwardly projecting latching shoulder (142) for engaging with an abutment (80) to latch the lever (6) in its closed position, the latching shoulder (142) being releasable from the abutment (80) by pressing the forward portion
- 25 30 35

- 5 (128) of the latch arm rearwardly; characterized in that the forward portion (128) of the latch arm (124) upstands from the latching shoulder (142) between forward side wall portions (136) of the lever (6), and in that a front end wall (138) of the lever (6), spanning the side wall portions (136), has a cut-out (140) allowing access to the forward portion (128) of the latch arm (124).
- 10 12. An assembly as claimed in claim 11, characterized in that the forward portion (128) of the latch arm (124) has a free end (134) which is substantially level with a top wall (116) of the lever (6).
- 15 13. An assembly as claimed in claim 11, characterized in that the cut-out has an arcuate base bowed towards the latching shoulder (142) and the cut-out (140) extends from the arcuate base to the level of a top wall (116) of the lever (6).
- 20 14. An assembly as claimed in claim 11, characterized in that a top wall (116) of the lever (6) is forwardly tapered from the rear end (100) of the lever (6) up to the forward side wall portions (136) of the lever (6).
- 25 15. An assembly as claimed in any one of the preceding claims, characterized in that said abutment is provided by a top wall (80) of a latch arm receiving receptacle (76) in the frame (4), and in that the latch arm (124) extends only partially between the forward side wall portions (136) of the lever (6), thereby leaving a forward lower shoulder (144) of the lever (56) free to abut the frame (4).
- 30 16. An assembly as claimed in any one of the preceding claims, characterized in that the latch arm (124) is formed with longitudinal reinforcing corrugations (146).
- 35 17. An assembly as claimed in any one of the preceding

-18-

claims, characterized in that the forward portion (128) of the latch arm (124) is stiffly resiliently flexible about said bight (130).

- 5 18. An assembly as claimed in any one of the preceding claims, characterized in that the lever (6) is so dimensioned that it only partially covers the frame (4) in the closed position of the lever (6).

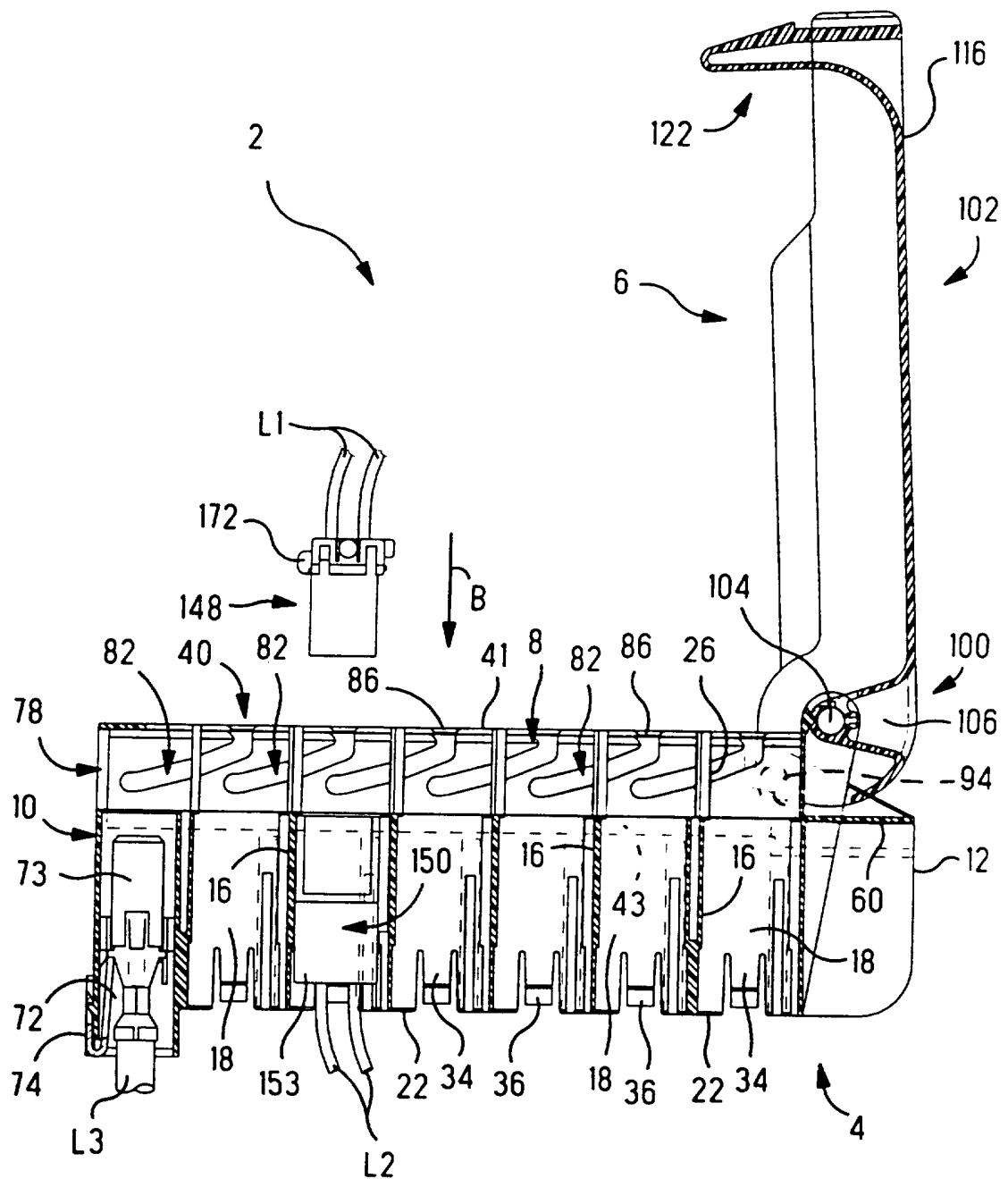

FIG. 1

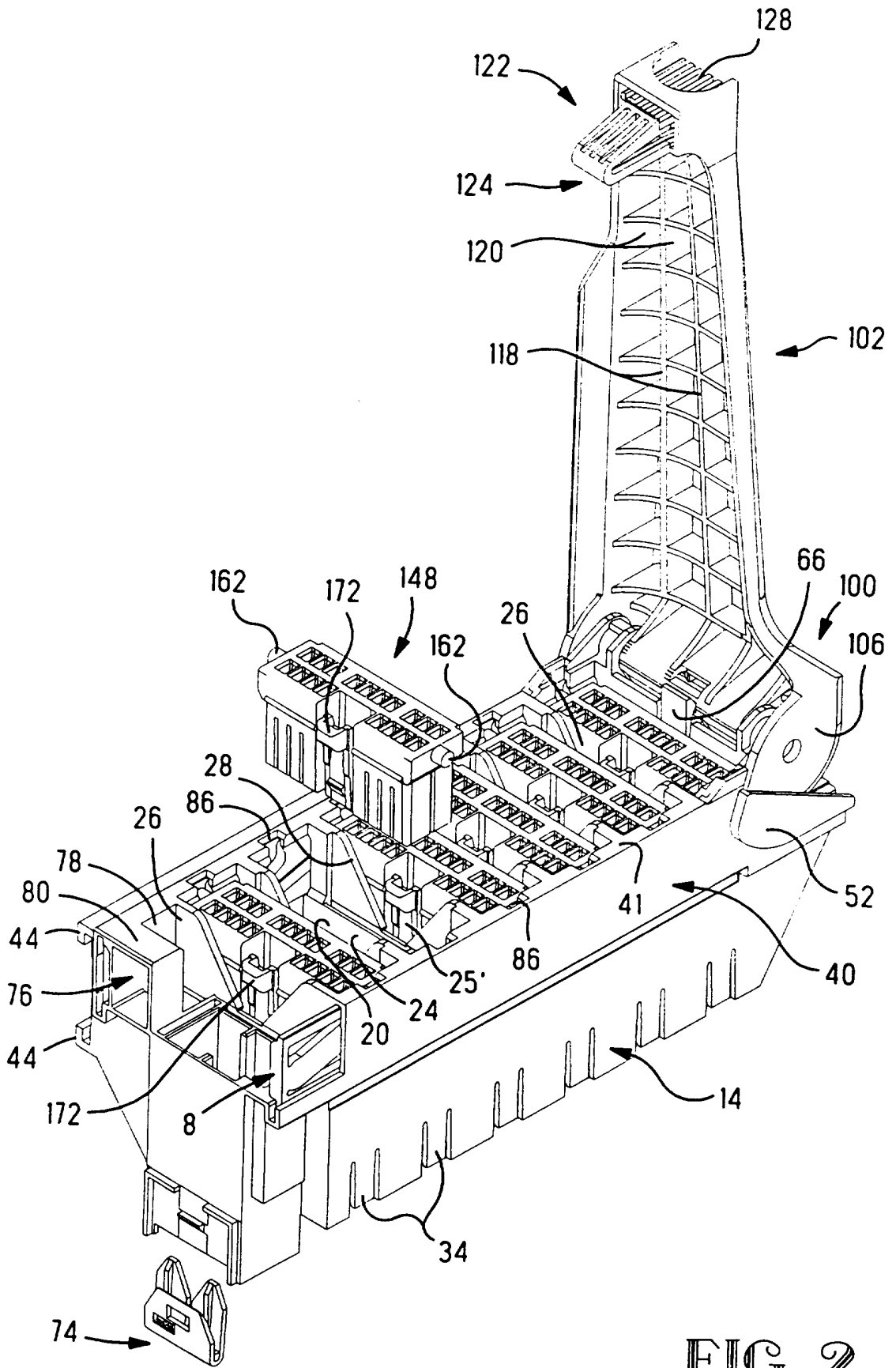

FIG. 2

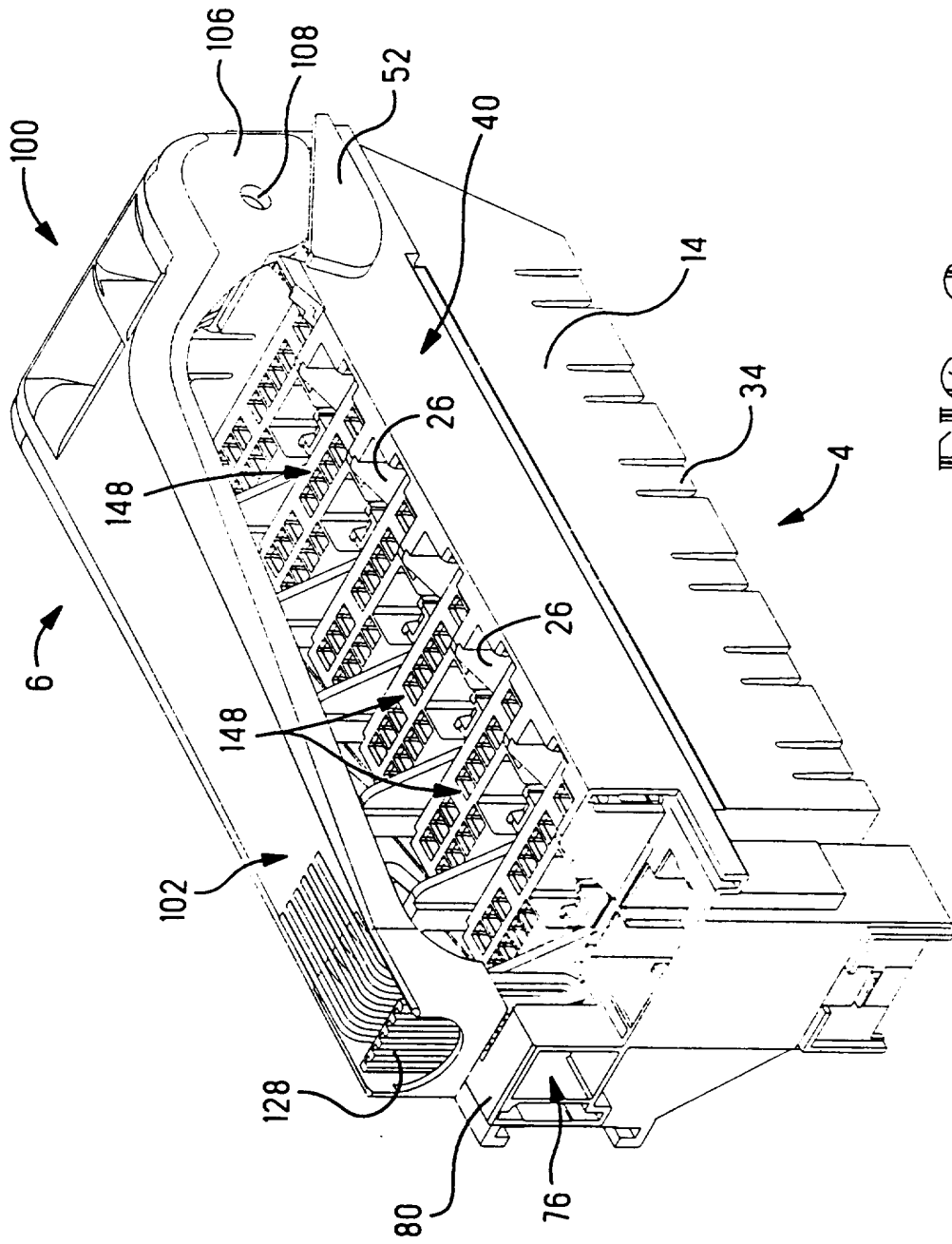

FIG. 3

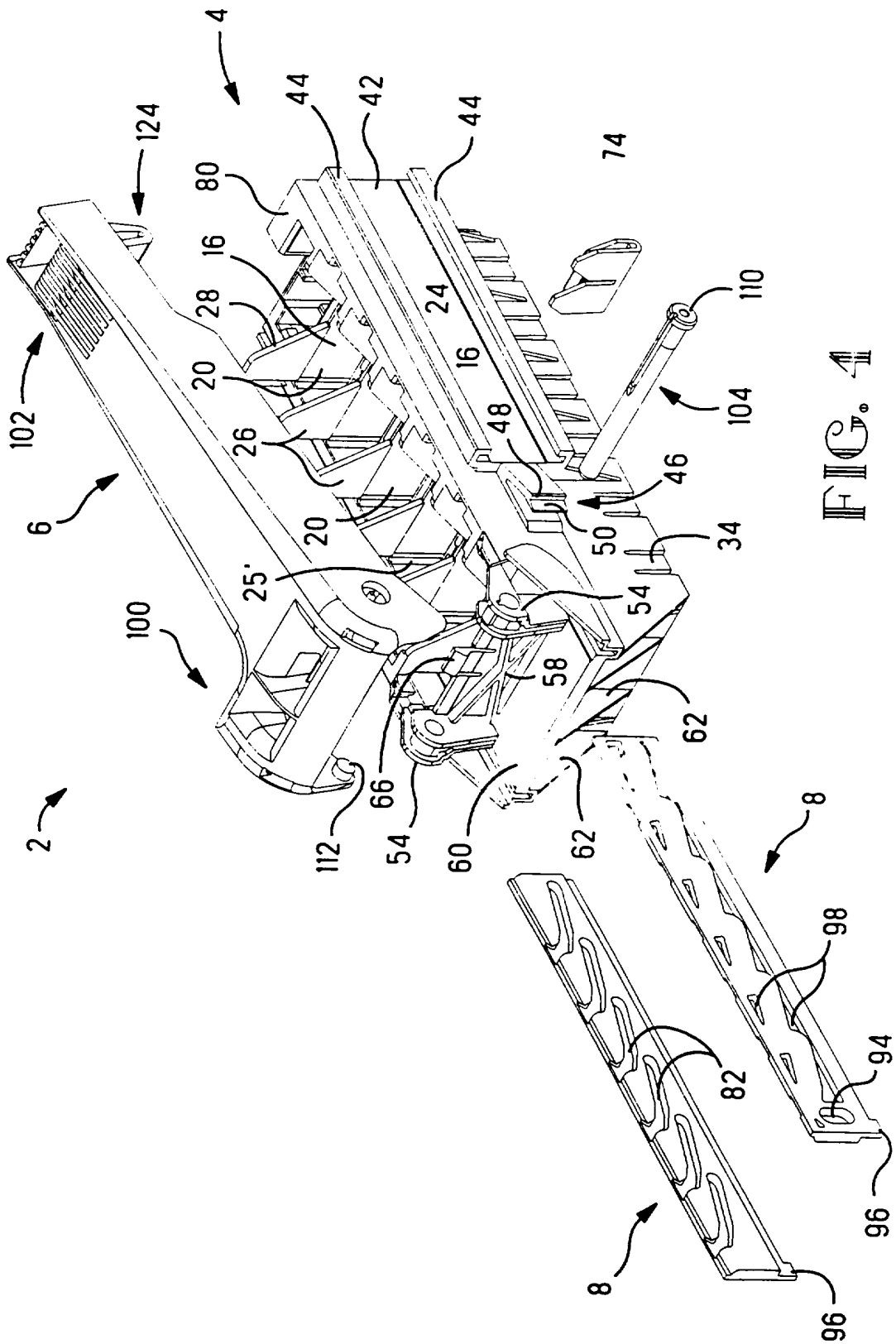

FIG. 4

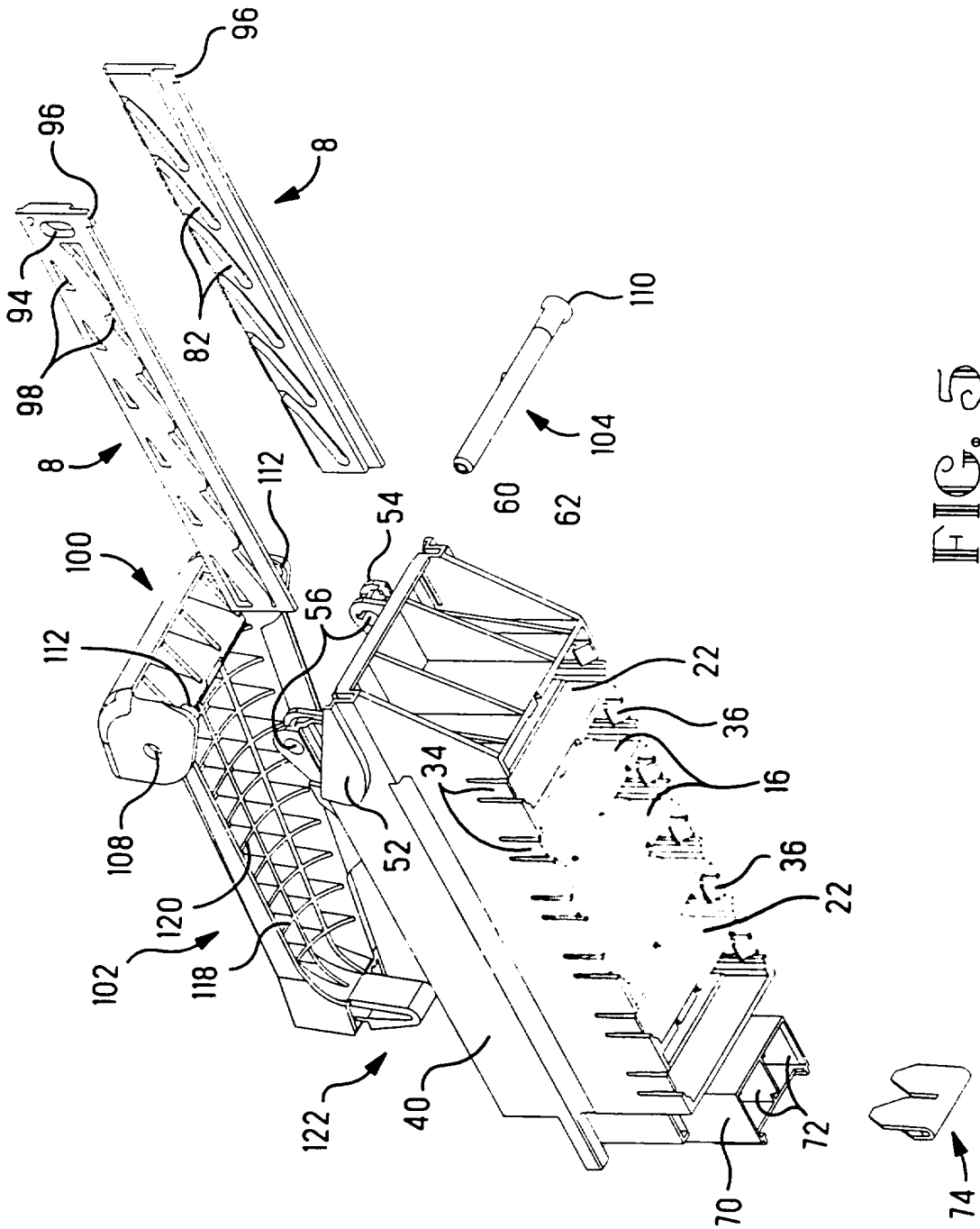

FIG. 5

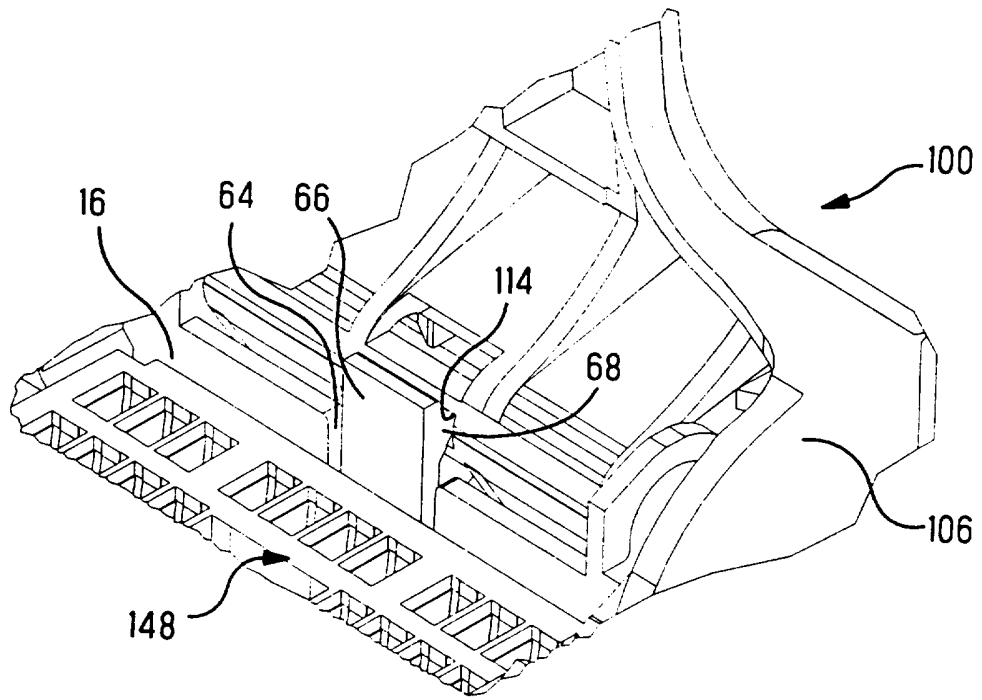

FIG. 6

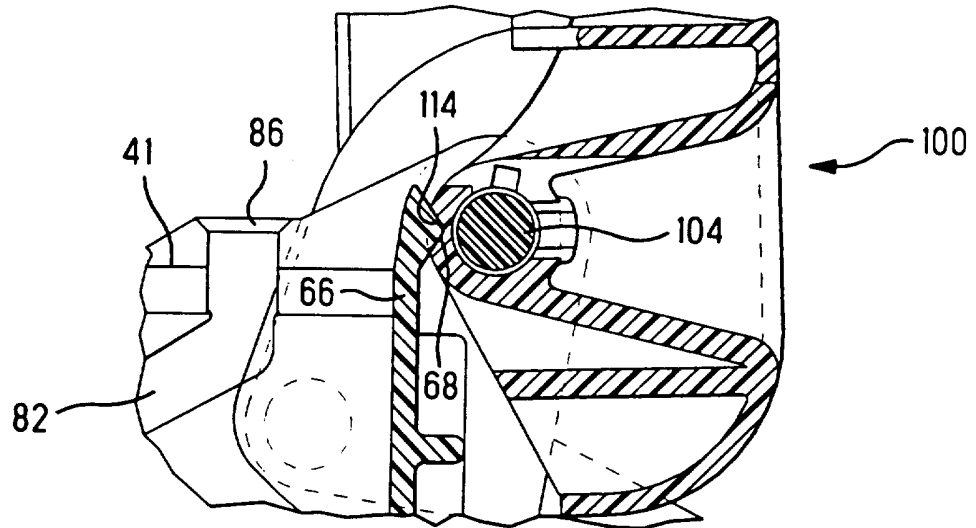

FIG. 7

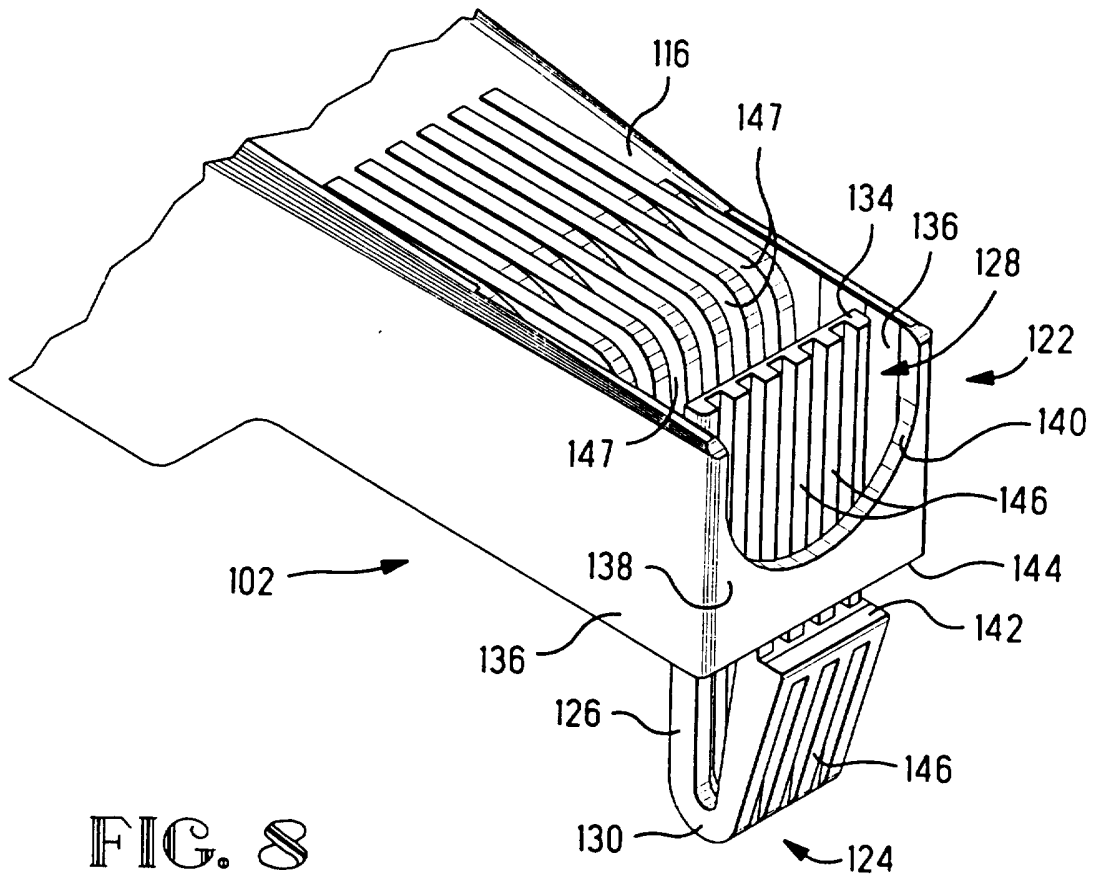

FIG. 8

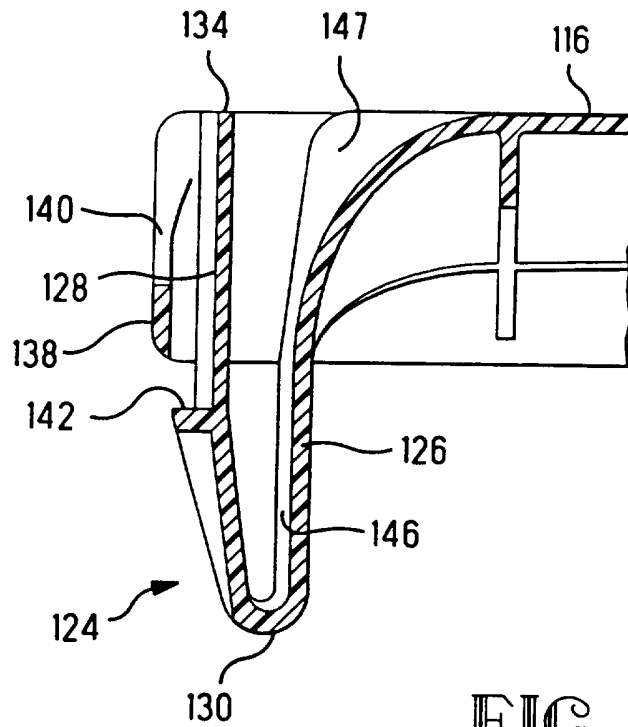

FIG. 9

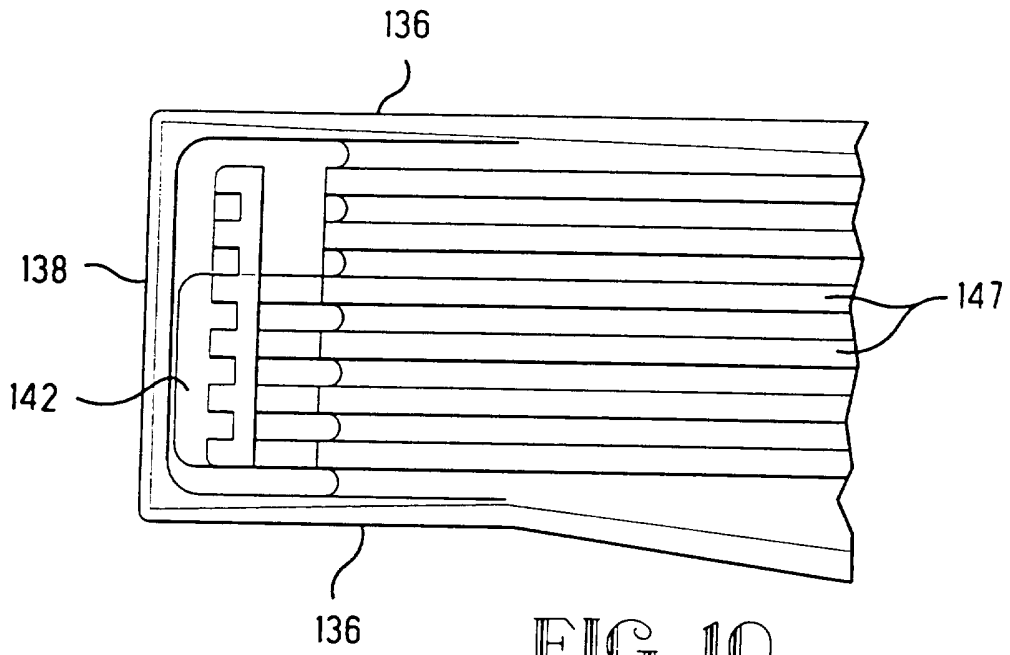

FIG. 10

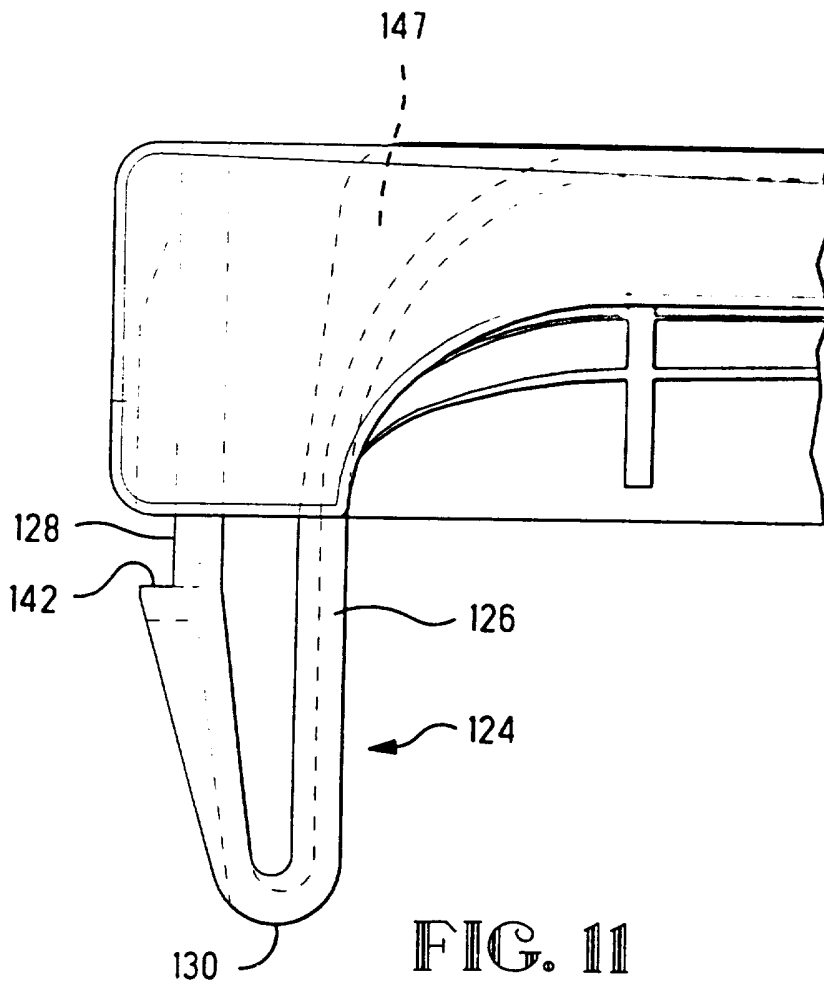

FIG. 11

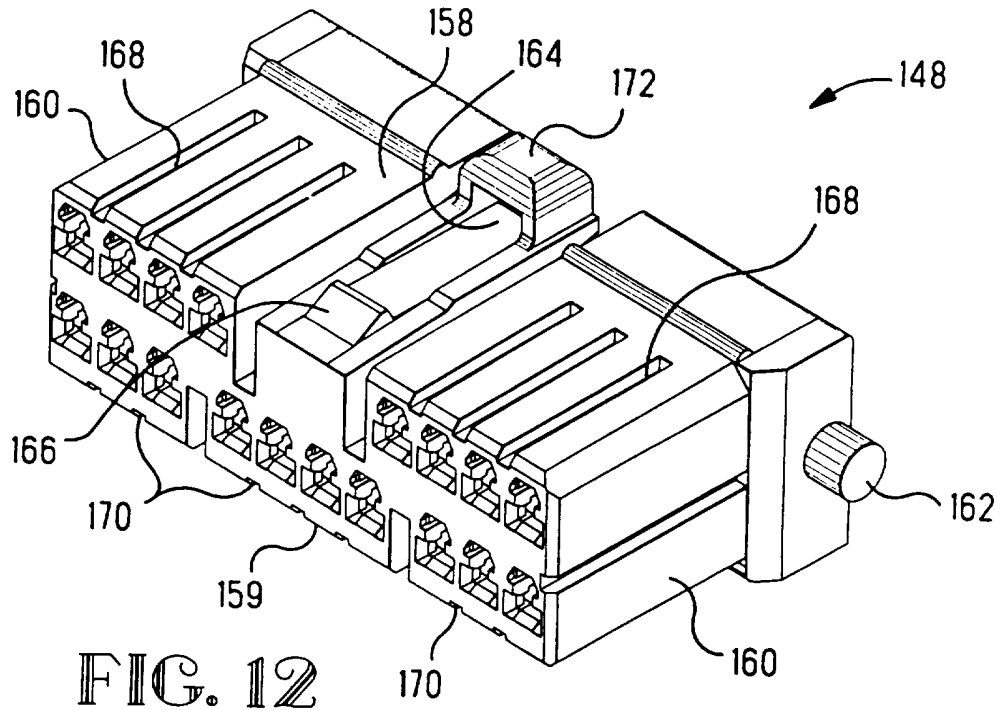

FIG. 12

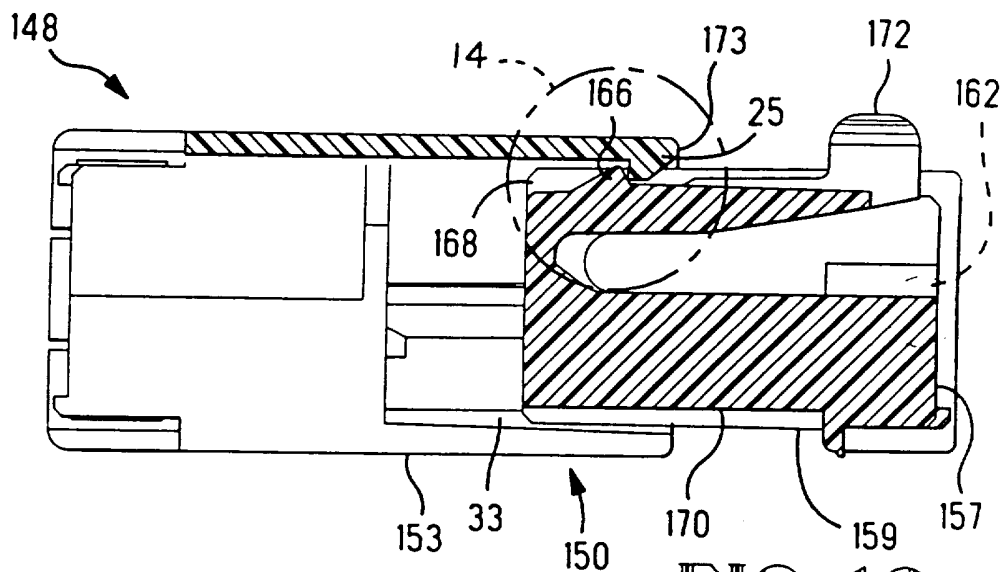

FIG. 13

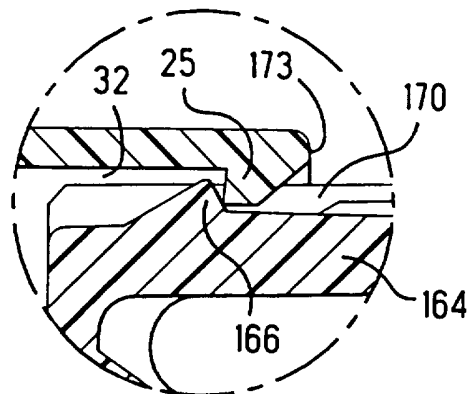
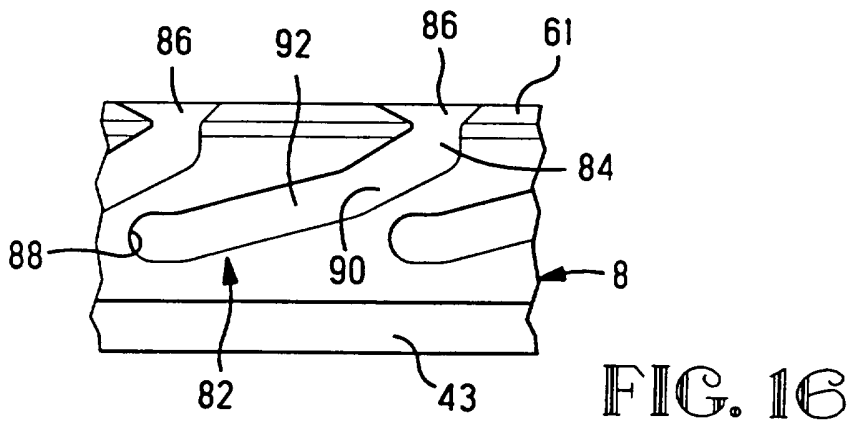
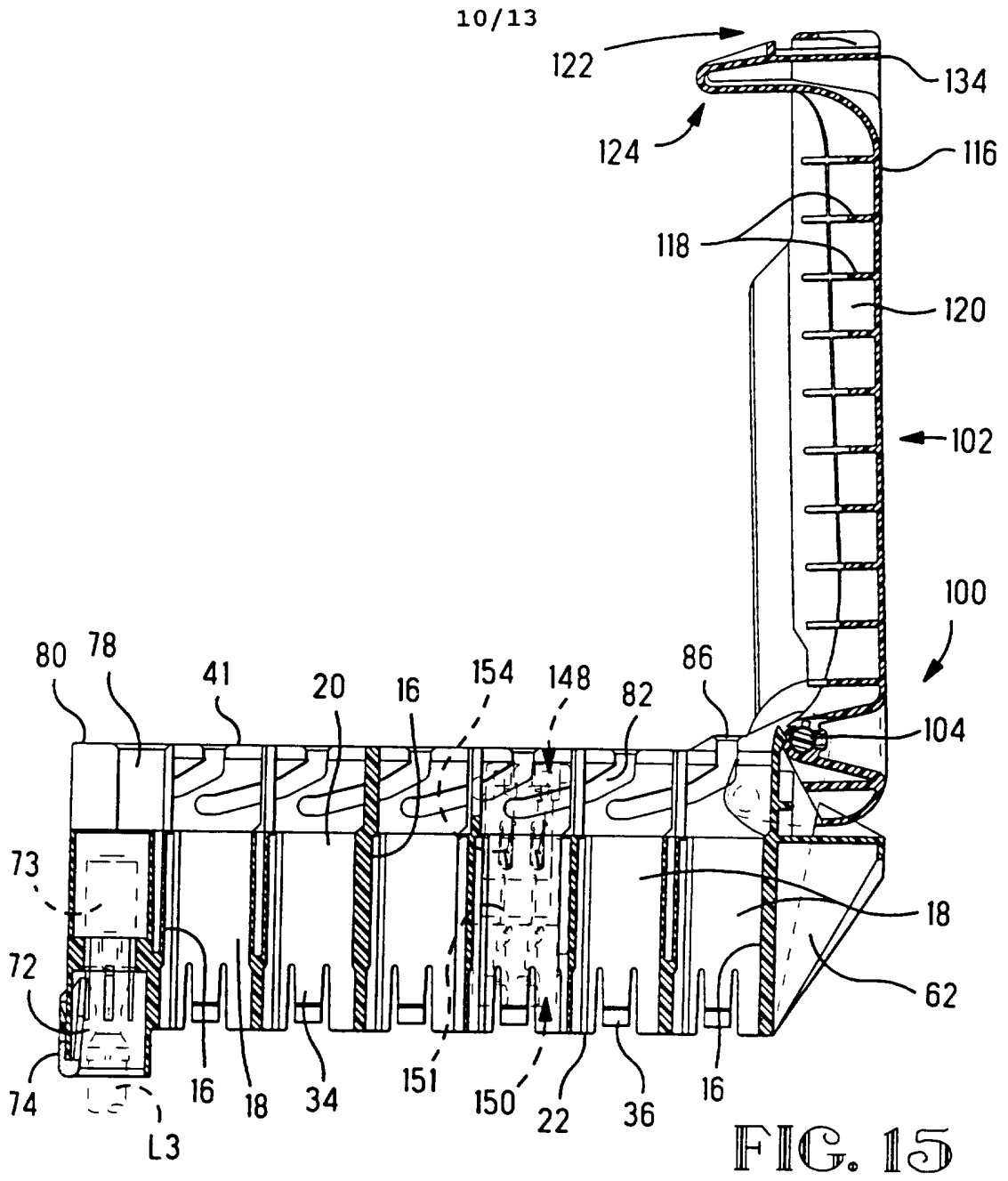

FIG. 14



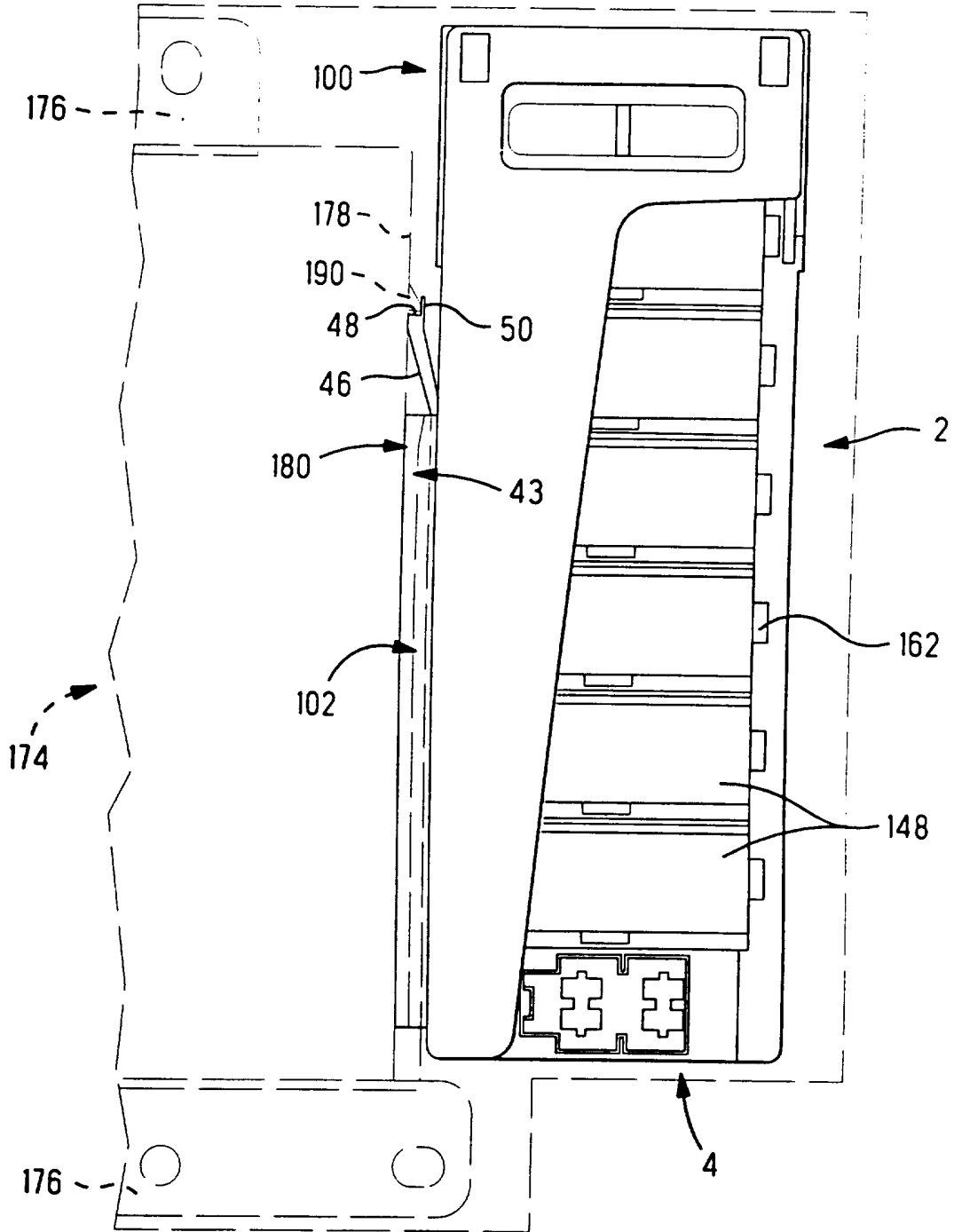

FIG. 17

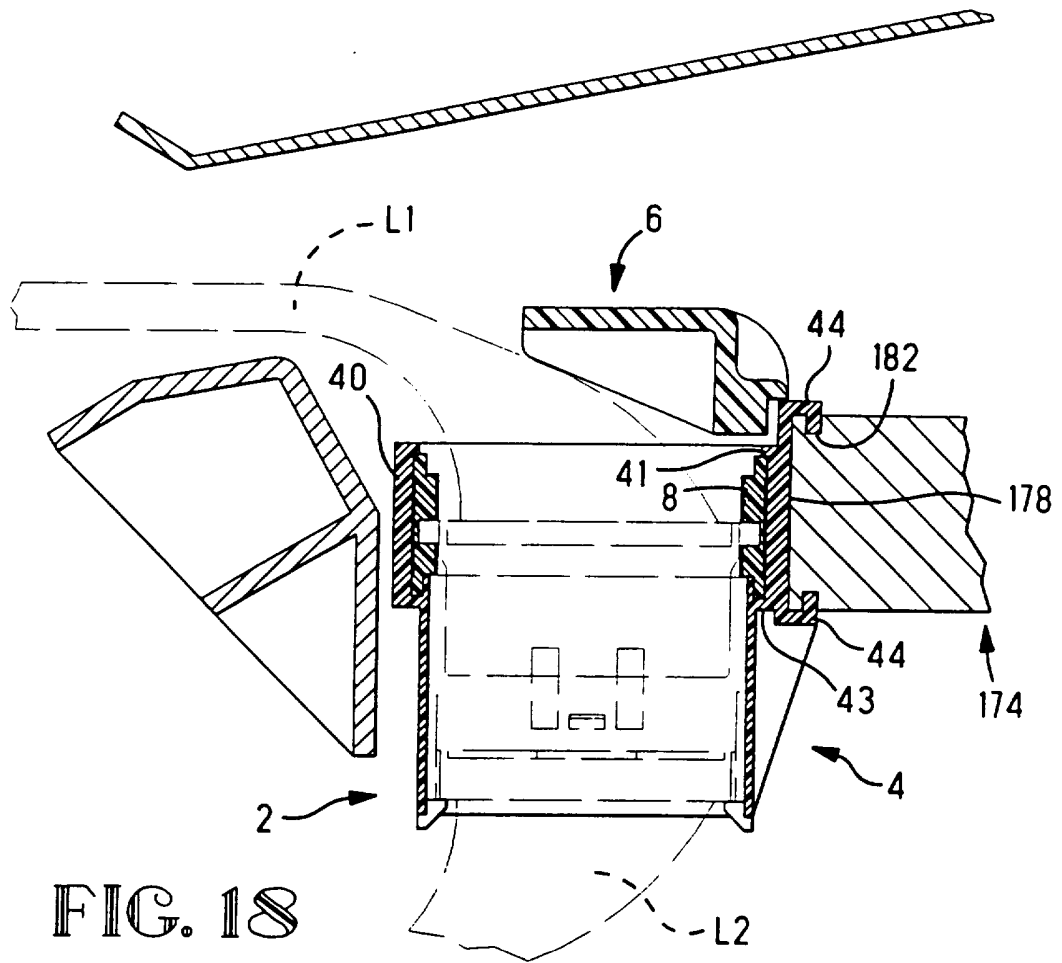

FIG. 18

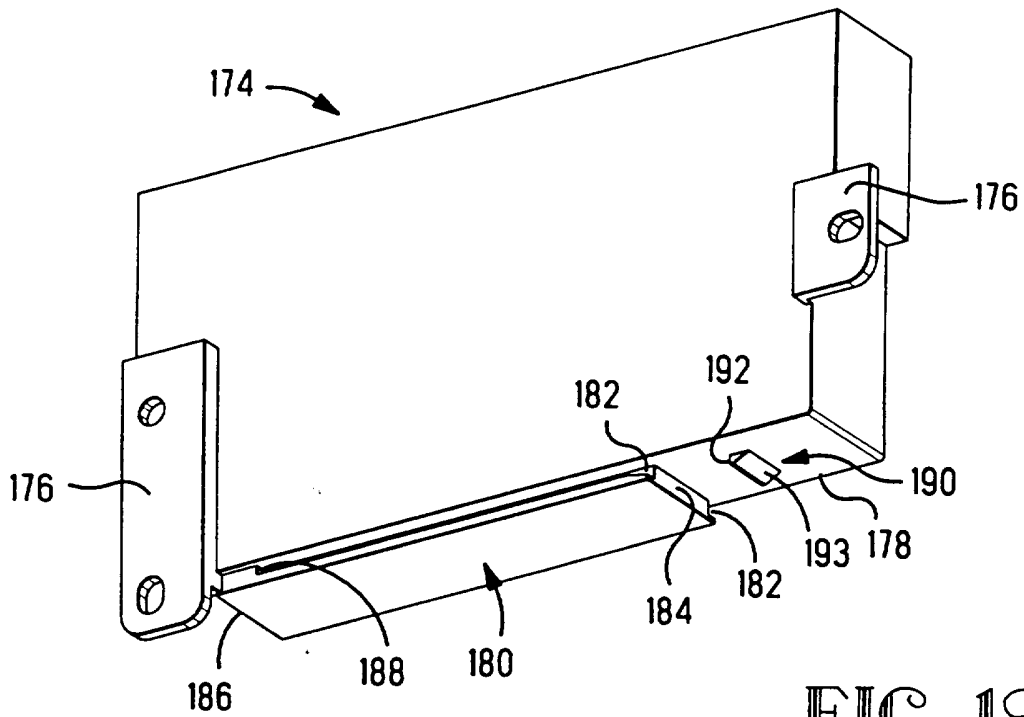

FIG. 19

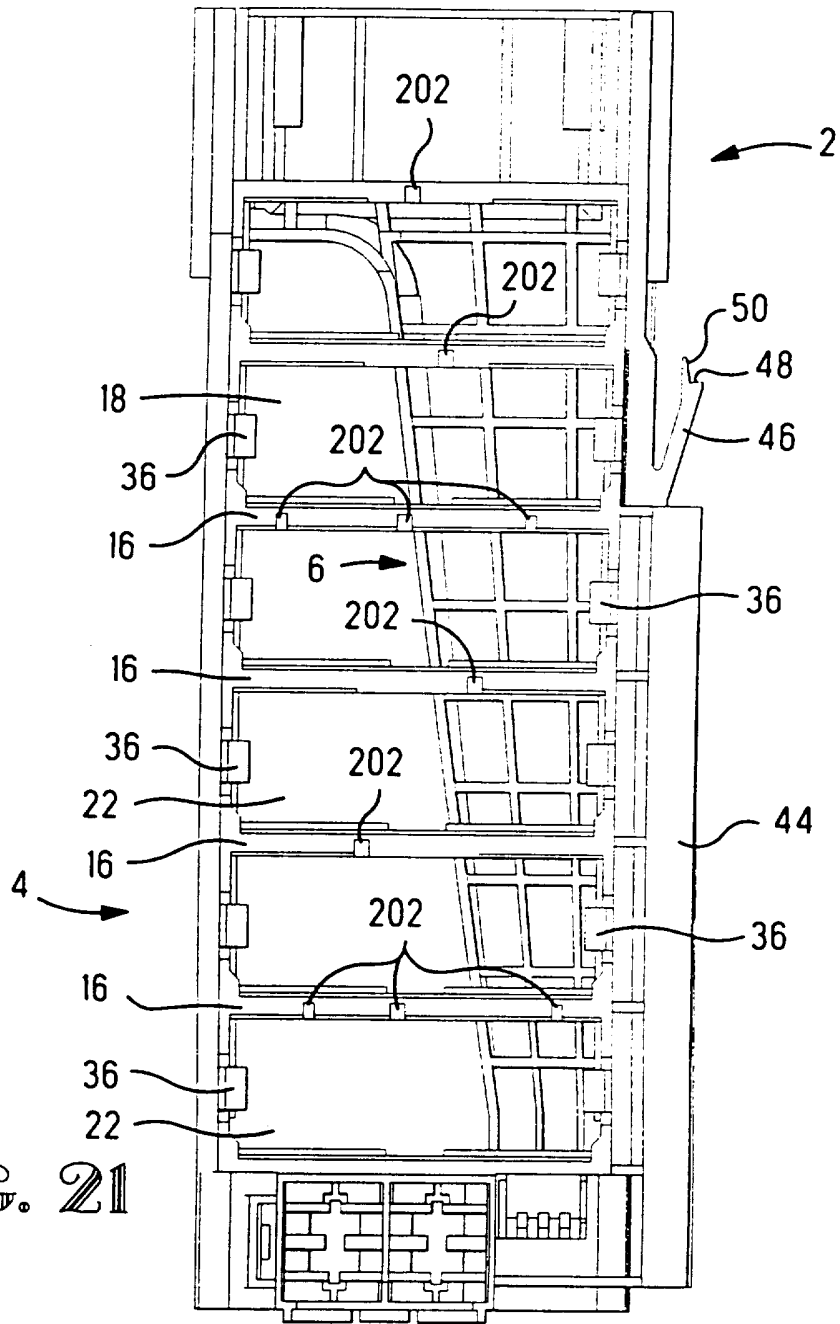

FIG. 21

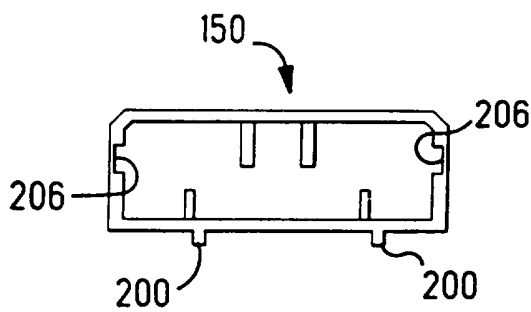

FIG. 20

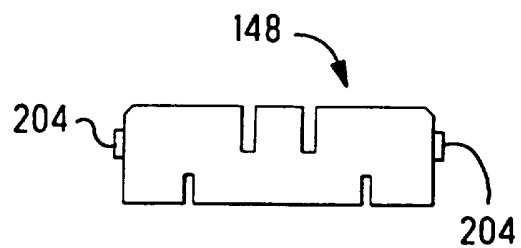

FIG. 22

INTERNATIONAL SEARCH REPORT

Intern. onal application No.

PCT/IB 96/00314

A. CLASSIFICATION OF SUBJECT MATTER

IPC6: H01R 13/629

According to International Patent Classification (IPC) or to both national classification and IPC

B. FIELDS SEARCHED

Minimum documentation searched (classification system followed by classification symbols)

IPC6: H01R

Documentation searched other than minimum documentation to the extent that such documents are included in the fields searched

Electronic data base consulted during the international search (name of data base and, where practicable, search terms used)

C. DOCUMENTS CONSIDERED TO BE RELEVANT

Category*	Citation of document, with indication, where appropriate, of the relevant passages	Relevant to claim No.
Y	EP, A1, 0363804 (AMP INCORPORATED), 18 April 1990 (18.04.90), figure 1, abstract --	1-2,18
Y	DE, A1, 4336711 (YAZAKI CORP), 5 May 1994 (05.05.94), column 4, line 68 - column 5, line 55, figure 1 --	1-2,18
A	EP, A2, 0549371 (SUMITOMO WIRING SYSTEMS, LTD.), 30 June 1993 (30.06.93), abstract --	1,11
A	EP, A2, 0273999 (AMP INCORPORATED), 13 July 1988 (13.07.88), abstract --	1,11

 Further documents are listed in the continuation of Box C.
 See patent family annex.

- * Special categories of cited documents:
- * "A" document defining the general state of the art which is not considered to be of particular relevance
 - * "E" earlier document but published on or after the international filing date
 - * "L" document which may throw doubts on priority claim(s) or which is cited to establish the publication date of another citation or other special reason (as specified)
 - * "O" document referring to an oral disclosure, use, exhibition or other means
 - * "P" document published prior to the international filing date but later than the priority date claimed
 - * "T" later document published after the international filing date or priority date and not in conflict with the application but cited to understand the principle or theory underlying the invention
 - * "X" document of particular relevance: the claimed invention cannot be considered novel or cannot be considered to involve an inventive step when the document is taken alone
 - * "Y" document of particular relevance: the claimed invention cannot be considered to involve an inventive step when the document is combined with one or more other such documents, such combination being obvious to a person skilled in the art
 - * "&" document member of the same patent family

Date of the actual completion of the international search

12 July 1996

Date of mailing of the international search report

31.07.96

Name and mailing address of the International Searching Authority



European Patent Office, P.B. 5818 Patentlaan 2
NL-2280 HV Rijswijk
Tel. (-31-70) 340-2040, Tx. 31 651 epo nl,
Fax: (-31-70) 340-3016

Authorized officer

Paul Winblad

INTERNATIONAL SEARCH REPORT

International application No.

PCT/IB 96/00314

C (Continuation). DOCUMENTS CONSIDERED TO BE RELEVANT

Category*	Citation of document, with indication, where appropriate, of the relevant passages	Relevant to claim No.
A	US, A, 5320544 (T. NAOTO ET AL), 14 June 1994 (14.06.94), abstract ----- -----	1,11

INTERNATIONAL SEARCH REPORT

SA '9064

Information on patent family members

01/04/96

International application No.

PCT/IB 96/00314

Patent document cited in search report	Publication date	Patent family member(s)	Publication date
EP-A1- 0363804	18/04/90	DE-D, T- 68915925 ES-T- 2054976 JP-A- 2123681	22/09/94 16/08/94 11/05/90
DE-A1- 4336711	05/05/94	NONE	
EP-A2- 0549371	30/06/93	JP-A- 5182716	23/07/93
EP-A2- 0273999	13/07/88	DE-D- 3787636 DE-U- 8700210 ES-T- 2043613	00/00/00 02/07/87 01/01/94
US-A- 5320544	14/06/94	JP-A- 5290921	05/11/93