

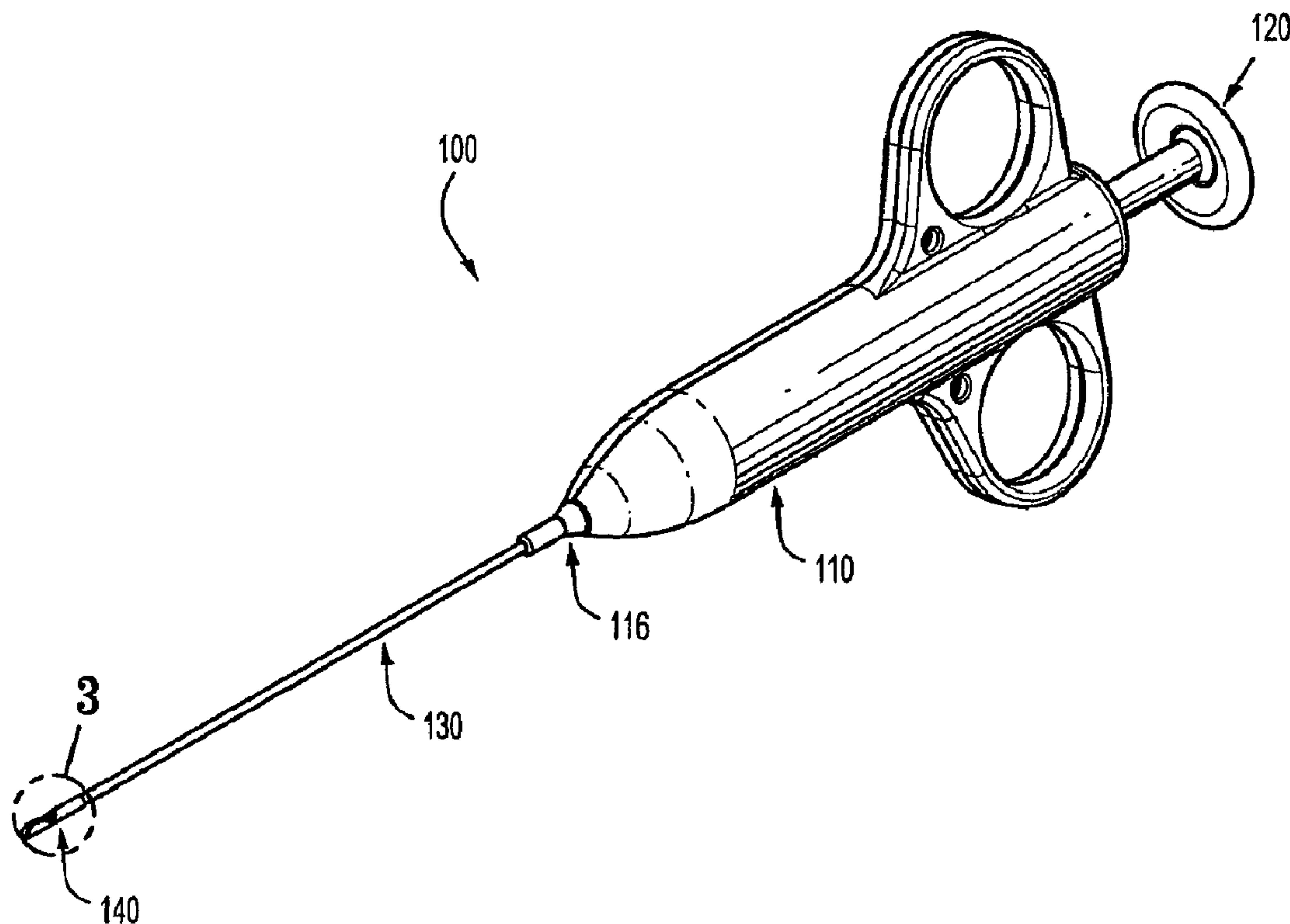

(22) Date de dépôt/Filing Date: 2010/10/12
 (41) Mise à la disp. pub./Open to Public Insp.: 2011/04/13
 (62) Demande originale/Original Application: 2 717 448
 (30) Priorités/Priorities: 2009/10/13 (US61/250,894);
 2010/10/05 (US12/897,868)

(51) Cl.Int./Int.Cl. *A61B 17/10* (2006.01)
 (71) Demandeur/Applicant:
 TYCO HEALTHCARE GROUP LP, US
 (72) Inventeurs/Inventors:
 PRIBANIC, RUSSELL, US;
 MARCZYK, STANISLAW, US
 (74) Agent: OSLER, HOSKIN & HARCOURT LLP

(54) Titre : POSEUR D'AGRAFES CHIRURGICALES
 (54) Title: SUTURE CLIP APPLIER



(57) Abrégé/Abstract:

A suture clip for selective attachment to a suture, the suture clip comprising: an elongated flexible beam having a distal end portion, a proximal end portion, a top surface and a bottom surface, the flexible beam further including a pair of arms extending laterally

(57) **Abrégé(suite)/Abstract(continued):**

therefrom; and an elongated rigid channel. The elongated rigid channel has a substantially U- shaped transverse cross-sectional profile with a horizontal base wall and vertical side walls having a distal end portion and proximal end portion, wherein each vertical side wall defines a holding step formed in an upper edge thereof. The flexible beam and the channel are coupled to one another at their proximal end portions. The pair of arms of the flexible beam are in registration with a corresponding holding step formed in the upper edge of the vertical side walls.

ABSTRACT

A suture clip for selective attachment to a suture, the suture clip comprising: an elongated flexible beam having a distal end portion, a proximal end portion, a top surface and a bottom surface, the flexible beam further including a pair of arms extending laterally therefrom; and an elongated rigid channel. The elongated rigid channel has a substantially U-shaped transverse cross-sectional profile with a horizontal base wall and vertical side walls having a distal end portion and proximal end portion, wherein each vertical side wall defines a holding step formed in an upper edge thereof. The flexible beam and the channel are coupled to one another at their proximal end portions. The pair of arms of the flexible beam are in registration with a corresponding holding step formed in the upper edge of the vertical side walls.

SUTURE CLIP APPLIER

This application is a division of Canadian Serial No. 2,717,448 filed October 12, 2010.

BACKGROUND

1. Technical Field

[0002] The present disclosure relates to a device for use in a surgical procedure. More particularly, the present disclosure relates to a surgical suture clip applier adapted for securing sutures during an endoscopic or laparoscopic procedure.

2. Background of Related Art

[0003] In surgical operations it is well known that surgical sutures are applied to repair the body tissue. Such sutures generally are of the non-absorbable or the absorbable type and are generally applied with the use of surgical needles. If the sutures are non-absorbable, they may or may not be removed after an estimated predetermined healing period has passed. Absorbable sutures are absorbed gradually over time by coming in contact with moisture in the human body.

[0004] In many surgical procedures, application of sutures generally involves knotting or tying the suture after it is applied to the body tissue in order to retain its position with respect to

the tissue and to maintain the tissue in the repaired position. In cases where the surgeon has full access to the operative site by virtue of a large incision, knotting the suture or applying knotting or equivalent devices is relatively simple due to the access provided by the incision.

[0005] In endoscopic and laparoscopic procedures, on the other hand, large incisions are avoided. In laparoscopic procedures surgery is performed in the interior of the abdomen through a small incision; in endoscopic procedures surgery is performed in any hollow viscus of the body through narrow endoscopic tubes inserted through small entrance wounds in the skin. Laparoscopic and endoscopic procedures generally require that any instrumentation inserted into the body be sealed, i.e., provisions must be made to ensure that gases do not enter or exit the body through the laparoscopic or endoscopic incision as, for example, in surgical procedures in which the surgical region is insufflated. Moreover, laparoscopic and endoscopic procedures often require the surgeon to act on organs, tissues, and vessels far removed from the incision, thereby requiring that instruments to be used in such procedures generally be both long and narrow.

[0006] In laparoscopic and endoscopic procedures surgical sutures are generally applied by directing and manipulating needled sutures through an aperture in the body or through elongated narrow tubes known as cannulae with the assistance of specially designed needle graspers, needle drivers, and the like. However, tying the sutures in such procedures can be relatively difficult due to the limited access afforded to the surgeon through the narrow tubes. In particular, since biocompatible, preferably bioabsorbable, sutures are generally used in such procedures it would be desirable to have available a cinching device and system that facilitates tying the sutures through the tubes in a manner to retain their position in the body tissue at least

until the healing process is in full progress. The use of the term "endoscopic" herein contemplates endoscopic as well as laparoscopic procedures.

SUMMARY

[0007] The present disclosure relates to surgical suture clip appliers, suture clips and methods of their use for securing sutures during an endoscopic or laparoscopic procedure.

[0008] According to an aspect of the present disclosure, a suture clip applier is provided and includes a housing; an elongated plunger slidably supported in the housing, the plunger having a distal end portion disposed within the housing and a proximal end portion extending from a proximal end of the housing; a hollow tube extending distally from the housing and defining a lumen therethrough; an actuation member having a distal end extending into the hollow tube and a proximal end operatively engaged with the plunger; and a working tip coupled to a distal end of the hollow tube. The working tip has a substantially U-shaped transverse cross-sectional profile defining a channel having a base wall and a pair of spaced apart side walls. The working tip defines a lower contact surface along an internal face of the base wall, and an upper contact surface defined along an upper end surface of each side wall. The upper contact surface of each side wall includes a distal recess formed near a distal end of thereof and a proximal recess formed proximal of the distal recess; and an internal retaining surface on both side walls parallel to the base wall. In use, the distal end of the actuation member is configured to engage a suture clip loaded into the working tip.

[0009] The plunger may define a race formed in a surface thereof. The race may include a plurality of portions each defining a cam surface of varying depth. The clip applier may include a rocker arm having a distal end portion and proximal end portion. The rocker arm may

have a follower pin extending therefrom near the distal end portion thereof and a retaining pin near the proximal end portion thereof. The rocker arm may be pivotally attached to the housing by the retaining pin and the follower pin may be slidably disposed within the race of the plunger to modulate the motion of the plunger and actuation member.

[0010] The race may define four interconnected cam portions, with each cam portion having a start position and an end position, and each cam is deepest at its respective start position and shallowest at its respective end position.

[0011] The rocker arm may be elastically deformable laterally from the plunger thereby providing a biasing force upon the follower pin and plunger relative to the body.

[0012] The clip applier may further include finger loops extending from the housing.

[0013] The actuation member may be configured to transmit axial translative forces to the suture clip.

[0014] The clip applier may further include a biasing member disposed within the housing and providing a proximal bias upon the plunger relative to the housing. The biasing member may be a coil spring.

[0015] The distal recess and the proximal recess, formed in each vertical side wall, may be interconnected by a camming surface.

[0016] According to another aspect of the present disclosure, a suture clip for selective attachment to a suture is provided and includes an elongated flexible beam having a distal end portion, a proximal end portion, a top surface and a bottom surface, the flexible beam further

including a pair of arms extending laterally therefrom; and an elongated rigid channel, wherein the elongated rigid channel has a substantially U-shaped transverse cross-sectional profile with a horizontal base wall and vertical side walls having a distal end portion and proximal end portion, wherein each vertical side wall defines a holding step formed in an upper edge thereof. The flexible beam and the channel are coupled to one another at their proximal end portions; and the pair of arms of the flexible beam are in registration with a corresponding holding step formed in the upper edge of the vertical side walls.

[0017] A proximal end portion of the pair of vertical side walls of the channel of the suture clip may include inwardly projecting lips for retaining the proximal end portion of the beam within the channel. The proximal end portions of the beam and channel may be adhesively coupled to one another.

[0018] The pair of arms of the flexible beam may project beyond the pair of vertical side walls of the channel.

[0019] According to a further aspect of the present disclosure, a suture clip applier system is provided and includes a suture clip applier for filing a suture clip onto a suture. The clip applier includes a housing; an elongated plunger slidably supported in the housing, the plunger having a distal end portion disposed within the housing and a proximal end portion extending from a proximal end of the housing; a hollow tube extending distally from the housing and defining a lumen therethrough; an actuation member having a distal end extending into the hollow tube and a proximal end operatively engaged with the plunger; and a working tip coupled to a distal end of the hollow tube. The working tip has a substantially U-shaped transverse cross-sectional profile defining a channel having a base wall and a pair of spaced apart side walls. The

working tip defines a lower contact surface along an internal face of the base wall, and an upper contact surface defined along an upper end surface of each side wall. The upper contact surface of each side wall includes a distal recess formed near a distal end thereof and a proximal recess formed proximal of the distal recess; and an internal retaining surface on both side walls parallel to the base wall. The distal end of the actuation member is configured to engage a suture clip loaded into the working tip

[0020] The suture clip applier system further includes a suture clip loadable into and deployable from the working tip. The suture clip includes an elongated flexible beam having a distal end portion, a proximal end portion, a top surface and a bottom surface, the flexible beam further including a pair of arms extending laterally therefrom; and an elongated rigid channel, wherein the elongated rigid channel has a substantially U-shaped transverse cross-sectional profile with a horizontal base wall and vertical side walls having a distal end portion and proximal end portion, wherein each vertical side wall defines a holding step formed in an upper edge thereof. The flexible beam and the channel are coupled to one another at their proximal end portions. The pair of arms of the flexible beam are in registration with a corresponding holding step formed in the upper edge of the vertical side walls; and, in use, as the suture clip is urged in a distal direction relative to the working tip, the flexible beam is splayed apart from the channel to open the suture clip for receipt of a suture therein.

[0021] The plunger of the clip applier defines a race formed in a surface thereof, the race includes a plurality of portions each defining a cam surface of varying depth; and the clip applier includes a rocker arm having a distal end portion and proximal end portion, the rocker arm has a follower pin extending therefrom near the distal end portion thereof and a retaining pin near the proximal end portion thereof. The rocker arm is pivotally attached to the housing by the

retaining pin and the follower pin is slidably disposed with in the race of the plunger to modulate the motion of the plunger and actuation member.

[0022] The race may define four interconnected cam portion, with each cam portion having a start position and an end position and each cam is deepest at its respective start position and shallowest at its respective end position.

[0023] The rocker arm of the clip applier may be elastically deformable laterally from the plunger thereby providing a biasing force upon the follower pin and plunger relative to the body.

[0024] The clip applier may further include a biasing member disposed within the housing and providing a proximal bias upon the plunger relative to the housing. The distal recess and the proximal recess formed in each vertical side wall may be interconnected by a camming surface.

[0025] A proximal end portion of the pair of vertical sides walls of the channel of the suture clip may include inwardly projecting lips for retaining the proximal end portion of the beam within the channel. The pair of arms of the suture clip may project beyond the pair of vertical side walls of the channel thereof.

[0026] According to yet another aspect of the present disclosure, a method of securing a suture through an incision is provided. The method includes the steps of providing a suture clip applier having a working tip configured to retain and fire a suture clip; providing a suture clip having a biased closed configuration; loading the suture clip into the working tip of the clip applier; translating the suture clip distally relative to the working tip to a first position wherein the suture clip is splayed open; inserting a suture into the opened suture clip; and translating the

suture clip distally relative to the working tip such that the suture clip is ejected from the working tip and biased to the closed configuration to close on and to retain the suture.

[0027] According to still another embodiment of the present disclosure, a method of securing a suture through an incision is provided and includes the steps of providing a suture clip applicator having a working tip, and providing a suture clip. The working tip of the suture clip has a substantially U-shaped transverse cross-sectional profile defining a channel having a base wall and a pair of spaced apart side walls. The working tip defines a lower contact surface along an internal face of the base wall; and an upper contact surface defined along an upper end surface of each side wall. The upper contact surface of each side wall includes a distal recess formed near a distal end of thereof and a proximal recess formed proximal of the distal recess; and an internal retaining surface projecting inwardly from both side walls of the channel. The suture clip includes an elongated flexible beam having a distal end portion, a proximal end portion, a top surface and a bottom surface, the flexible beam further including a pair of arms extending laterally therefrom; and an elongated rigid channel. The elongated rigid channel of the suture clip has a substantially U-shaped transverse cross-sectional profile with a horizontal base wall and a pair of spaced apart vertical side walls having a distal end portion and a proximal end portion. Each vertical side wall of the suture clip defines a holding step formed in an upper edge thereof. The flexible beam and the channel of the clip are coupled to one another at their proximal end portions; and the pair of arms of the flexible beam are in registration with a corresponding holding step formed in the upper edge of the vertical side walls of the channel of the clip.

[0028] The method further includes the steps of loading a suture clip into the working tip such that the vertical side walls of the clip channel abut the retaining surface of the working tip,

and the laterally extending arms of the flexible beam rest in the proximal recess of the working tip; and translating the suture clip distally relative to the working tip such that the laterally extending arms of the suture clip are translated from the proximal recess of the working tip channel to the distal recess of the working tip while the clip channel is retained by the internal retaining surfaces of the working tip such that the distal ends of the flexible beam and the channel of the suture clip are separated to define an opening, and so that the distal end of the suture clip protrudes from the working tip.

[0029] The method further includes the steps of inserting a suture into the opening of the suture clip; and translating the suture clip distally relative to the working tip such that the suture clip is ejected from the working tip and the flexible beam and the channel of the clip are biased toward one another to close on and retain the suture.

BRIEF DESCRIPTION OF THE DRAWINGS

[0030] The present disclosure will be more fully appreciated as the same becomes better understood from the following detailed description when considered in connection with the following drawings, in which:

[0031] FIG. 1 is a perspective view of a clip applier according to an embodiment of the present disclosure;

[0032] FIG. 2 is a perspective view, with the parts separated, of the clip applier of FIG. 1;

[0033] FIG. 2A is an enlarged perspective view illustrating the connection of a crimp of an actuating member in a set screw;

[0034] FIG. 3 is an enlarged perspective view of the indicated area of detail of Fig. 1, illustrating a clip loaded in a distal end of the clip applier;

[0035] FIG. 4 is a perspective cut-away view of the clip applier of Fig. 1, illustrated with a body half-section removed therefrom;

[0036] FIG. 5 is an enlarged view of the proximal end portion of the suture clip applier of Fig. 3;

[0037] FIG. 6 is an enlarged perspective view of a suture clip according to an embodiment of the present disclosure, for use in the clip applier of Figs. 1-5;

[0038] FIG. 7A is an enlarged cross-sectional view of the working tip and clip according to section A of FIG. 2;

[0039] FIG. 7B is a side view of the working tip and clip of FIG. 2;

[0040] FIGS. 8A-D are schematic illustrations showing a sequence of operation of the clip applier of FIGS. 1-5;

[0041] FIG. 9 is a perspective view of a clip applier according to another embodiment of the present disclosure including a hook-shaped working tip for use with a flat suture clip;

[0042] FIG. 10 is a perspective view of the hook-shaped working tip illustrating an attachment of the suture clip to a suture;

[0043] FIG. 11 is a perspective view of the suture clip shown secured upon a suture;

[0044] FIG. 12 is a perspective view of another embodiment of a spring clip according to the present disclosure and shown in its neutral position;

[0045] FIG. 13 is a perspective view of the suture clip of FIG. 12 shown on a suture; and

[0046] FIG. 14 is a perspective view of a suture clip according to yet another embodiment of the present disclosure.

DETAILED DESCRIPTION OF THE EMBODIMENTS

[0047] While embodiments of the present disclosure are susceptible to various modifications and alternative constructions, certain illustrated embodiments thereof have been shown in the drawings and will be described below in detail. It should be understood, however, that there is no intention to limit the embodiments of the present disclosure to the specific form disclosed, but, on the contrary, the embodiments are intended to cover all modifications, alternative constructions, and equivalents falling within the spirit and scope of the present disclosure as defined in the claims.

[0048] While various embodiments of the invention are described herein, it is to be distinctly understood that this invention is not limited thereto but may be variously embodied to practice within the scope of the following claims. The present invention may be understood more readily by reference to the following detailed description of the invention taken in connection with the accompanying drawing figures, which form a part of this disclosure. It is to be understood that this invention is not limited to the specific devices, methods, conditions or parameters described and/or shown herein, and that the terminology used herein is for the

purpose of describing particular embodiments by way of example only and is not intended to be limiting of the claimed invention.

[0049] The present disclosure relates to devices and methods for applying suture clips in an endoscopic, endoluminal, laparoscopic, or other surgical setting. Throughout the following description, the term “proximal,” will refer to the end of a device or system that is closest to the operator, while the term “distal” will refer to the end of the device or system that is farthest from the operator.

[0050] With reference to FIGS. 1-7B, a clip applier, in accordance with the present disclosure, is generally designated as 100. Clip applier 100 includes a body or housing 110, a plunger 120 disposed substantially within body 110, a hollow outer tube 160 extending from and operatively supported by body 110, a working tip 140 supported on at a distal end of outer tube 160 and configured for operation on or with a suture clip 150, and an actuation member 130 extending through body 110 and hollow outer tube 160 and coupled at a proximal end thereof to plunger 120.

[0051] With reference to FIGS. 1, 2 and 4, body 110 is a hollow, elongated, annular member with a distal end portion 102 and proximal end portion 104 defining a longitudinal axis. The distal end portion 102 of body 110 has a frustoconical profile which narrows to define a distal opening 112a which is coincident with the exterior circumference of and supports a proximal end 160b of outer tube 160. As seen in FIG. 2, body 110 may be formed in a pair of half-sections 110a, 110b that are joined to one another using known techniques in the art, such as, for example, gluing, welding, fastening and the like.

[0052] As shown in FIGS. 1 and 2, it is contemplated that a substantially frustoconical, hollow strain relief 116, substantially composed of a compliant material, is disposed or supported at a distal end portion 102 of body 110. Strain relief 116 is configured to permit outer tube 160 to pass therethrough in order to provide a bias to outer tube 160 in order to help maintain outer tube in substantially parallel relation with the longitudinal axis.

[0053] With further reference to FIGS. 1, 2 and 4, a proximal end portion 104 of body 110 further includes opposing co-planar annular projections defining finger engaging loops 114a, 114b.

[0054] With reference to FIG. 4, plunger 120 is an elongated substantially cylindrical member defining a distal body portion 122 disposed within body 110 and a proximal end portion 123 projecting from the proximal end portion 104 of body 110. Distal body portion 122 of plunger 120 has a pair of opposed, protruding, longitudinally extending rails 122a (see FIG 5) configured to be slidably retained within a complementary recess 110c (only one recess shown in FIG. 2) formed in an internal face of body half 110b of body 110 so as to facilitate linear translation along the longitudinal axis of body 110.

[0055] Proximal end portion 123 of plunger 120 protrudes from body 110. Proximal end portion 123 of plunger 120, which protrudes from body 110, defines an actuation portion 123a which may be configured to be actuated by an operator's thumb, linear actuator, or other linear motion device known in the art.

[0056] Clip applier 100 includes a biasing member 118 disposed within body 110 and retained between the distal end of plunger 120 and an internal distal surface of body 110.

Biasing member 118 may be an elastically deformable helical coil which provides a biasing force upon plunger 120 relative to body 110.

[0057] With reference to FIGS. 4 and 5, one or more sides of distal body portion 122 of plunger 120 are flattened to define a surface 122b. Further, distal body portion 122 includes an audible/tactile feedback member defined by a race 124e formed in surface 122b of distal body portion 122. Race 124e includes a series of cam channels 124a-124d, each defining stepped or sloping cam surfaces 125a-125d. The depth of cam channels 124a-124d is such that they are deepest at the furthest counter-clockwise point along their respective paths. Race 124e accommodates a follower pin 126 that is coupled to and projects transversely from an end of a rocker arm 128 which is itself pivotally connected to body 110 by a proximal pin 129. Rocker arm 128 may be in the form of a biasing member, such as a leaf spring, to thereby exert a force upon follower pin 126 relative to body 110 so as to bias follower pin 126 against sloping cam surfaces 125a-125d of race 124e which provides control of the plunger stop positions as further detailed below.

[0058] The motion of plunger 120, actuating member 130 and clip 150 are modulated by the travel of follower pin 126 through race 124e. Plunger 120, actuating member 130, and clip 150 cannot be displaced until the proximal end portion 123 of plunger 120 is translated distally relative to body 110 by the operator, with sufficient force to overcome the biasing forces of biasing member 118 and rocker arm 128 and displace follower pin 126 along cam surfaces 125a-125d of race 124e. When plunger 120 is so actuated, follower pin 126 is caused to travel clockwise through the aforementioned cams. As follower pin 126 translates along a particular cam channel 124a-124d, respective cam surface 125a-125d urges follower pin 126 out of race 124e and exerts a biasing force on rocker arm 128. As follower pin 126 passes from one cam

channel 124a-124d to an adjacent cam channel 124a-124d, across the step defined between adjacent cam surfaces 125a-125d, the bias force of the rockers arm 128 drive follower pin 126 against a cam surface 125a-125d, thereby creating an audible/tactile indication to the user. An audible/tactile indication may be provided for each stage of the firing sequence.

[0059] With reference to FIGS. 1 and 2, outer tube 160 of clip applier 100 is a hollow elongated tubular member including a distal end portion 160a, a proximal end portion 160b, and a lumen extending therethrough. Actuation member 130 is slidably disposed at least partially within the lumen of outer tube 160. It is contemplated that outer tube 160 may be rigid or flexible. It is further contemplated that outer tube 160 is a hollow tube with a substantially elliptical or rectilinear traverse cross-sectional profile.

[0060] With continued reference to FIGS. 1 and 2, actuation member 130 of clip applier 100 is a solid shaft like member including a distal end portion 130a and a proximal end portion 130b. As mentioned above, distal end portion 130a of actuation member 130 extends through the lumen of outer tube 160, and proximal end portion 130b of actuation member 130 is connected or secured to distal body portion 122 of plunger 120.

[0061] As seen in FIGS. 2, 2A, 4 and 5, clip applier includes a set screw 170 disposed in plunger 120 and secured to actuation member 130. In particular, set screw 170 defines a shaped cavity 170a configured to receive a stop or crimp 130c affixed to proximal end 130b of actuation member 130, whereby set screw 170 is axially and rotatably fixed with respect to actuation member 130. Additionally, a proximal end 160c of outer tube 160 is received and secured within a distal end of set screw 170. It is contemplated that proximal end 160c of outer tube 160 is threadably connected to set screw 170. In this manner, as set screw 170 is rotated with respected

to outer tube 160, outer tube 160 is axially displaced relative to actuation member 130. In this manner, set screw 170 functions to enable fine tuning of the position of a distal tip or distal end portion 130a of actuation member 130 relative to distal end 160a of outer tube 160.

[0062] With reference to FIGS. 3 and 7A, working tip 140 of clip applicator 100 is operatively supported at its proximal end portion 140a to a distal end 160a of outer hollow tube 160. Working tip 140 has a substantially centrally disposed lumen 144 having a transverse cross-sectional profile, at the distal end of working tip 140, that is configured to retain clip 150. The shape of working tip 140 is described in greater detail hereinbelow.

[0063] With reference to FIGS. 3, 7A and 7B, lumen 144 of working tip 140 is enclosed near a proximal end portion 140b thereof. Meanwhile, a distal end portion 140a of working tip 140 has been cut away to reveal or expose lumen 144, thereby defining a channel 146 having a pair of contact or cam surfaces 141 along which a cross beam 155 of suture clip 150 can travel, as will be described in greater detail below.

[0064] With reference to FIG. 7A, channel 146 of working tip 140 includes a base wall 146a and a pair of upstanding side walls 146b, 146c. Each side wall 146b, 146c defines a respective ledge 146d, 146e, extending into lumen 146 and extending substantially along the length of working tip 140.

[0065] With reference to FIG. 7B, upstanding side walls 146b, 146c have material removed therefrom defining a cam surface 141 along which traverse cross beams 155 of clip 150 can travel. Cam surface 141 includes, beginning with the proximal-most portion of the cam surface 141, a proximal shoulder 141a, a proximal retaining groove 141b, a medial incline 141c, a distal retaining groove 141d, and a distal ejection shoulder 141e.

[0066] As shown in FIG. 6, a suture clip 150, according to the present disclosure, includes a clip beam 151 connected to a clip channel 152. A distal end 152a of clip channel 152 has a substantially U-shaped traverse cross-sectional profile with a base wall 152b and a pair of spaced apart upstanding side walls 152c, 152d. The upstanding side walls 152c, 152d of clip channel 152 each have a rounded forward edge 153, a distal retaining step or shoulder 156, and a clip beam recess 157 cut into the upper surface thereof. Clip channel 152 is dimensioned for slidable reception in lumen 144 of working tip 140 such that upstanding side walls 152c, 152d of clip channel 152 are disposed beneath ledges 146d, 146e of side walls 146b, 146c of channel 146 of working tip 140.

[0067] Clip beam 151 has a pair of transverse cross beams 155 extending therefrom at a location disposed proximally from distal tip 154 of clip beam 153. When the components of clip 150 are assembled, clip beam 151 is disposed between upstanding side walls 152c, 152d of clip channel 152. Further, clip beam 151 and clip channel 152 are secured or coupled at their proximal ends and separable at their distal ends. The proximal ends of clip beam 151 and clip channel 152 are coupled to one another by retaining bends 158 extending from side walls 152c, 152d. It is contemplated that the proximal ends of clip beam 151 and clip channel 152 may be coupled by a pin, chemical adhesive, weld, or other coupling or laminating method known in the art.

[0068] It is contemplated that clip beam 151 is constructed of a flexible, resilient, spring-like-material urging or biasing the assembled clip into a "closed" configuration wherein the distance between the distal ends of the clip beam 151 and clip channel 152 is minimized. It is further contemplated that clip beam 151 may be substantially composed of a permanent material

such as a metal (stainless steel or titanium) or a polymer, or a non-permanent material such as bio-absorbable natural or manmade polymer.

[0069] Referring now to FIGS. 8A-8D, a method of using clip applicator 100 and suture clip 150 is shown and will be discussed. Initially, as shown in FIG. 8A, a clip 150 is placed or loaded into the lumen 144 of the working tip 140 either by manually inserting clip 150 or by an automatic dispensing mechanism such that the proximal end of clip 150 abuts the distal end of the actuation member 130 and the lateral cross beams 155 of clip 150 rest within cam surfaces 141 of working tip 140. In particular, lateral cross-beams 155 of clip 150 rest in the nadir 141b of cam surfaces 141, between a proximal shoulder 141a and medial incline 141c of cam surface 141. In this initial configuration, plunger 122 is disposed at a proximal most position relative to body 110 such that follower pin 126 is disposed in a first cam channel portion 124a of race 124e (see FIG. 5).

[0070] Next, as shown in FIGS. 5 and 8B, as plunger 120 is depressed (i.e., translated distally relative to body 110), follower pin 126 is translated through race 124e from first cam channel portion 124a to second cam channel portion 124b. As follower pin 126 is translated from first cam channel portion 124a to second cam channel portion 124b, an audible/tactile indication is created, in the manner described above.

[0071] By depressing plunger 120 to translate plunger 120 distally, actuation member 130 is also translated distally which translates clip 150 distally such that cross-beam 155 is disposed upon distal retaining groove 141d of cam surfaces 141 of working tip 140. The translation of cross beam 155 to distal retaining groove 141d urges clip beam 151 away from

beam channel 152 which is retained by ledges 146d, 146e. This separates distal beam tip 154 from clip channel 152 to define opening 127 exposing suture retaining step 156.

[0072] Next, as shown in FIG. 8C, clip applicer 100 is maneuvered to capture a suture 131 in opening 127 or a suture 131 is moved into opening 127. With suture 131 disposed within opening 127, plunger 120 is further depressed (i.e., translated distally relative to body 110), thereby translating follower pin 126 through race 124e from second cam channel portion 124b to third cam channel portion 124c. As follower pin 126 is translated from second cam channel portion 124b to third cam channel portion 124c, an audible/tactile indication is created, in the manner described above. As plunger 120 is further depressed, actuating member 130 is further translated in a distal direction thereby translating clip 150 distally until cross beams 155 are moved onto respecting distal ejection shoulders 141e of working tip 140, thus partially closing clip 150 (i.e., approximating clip beam 151 and clip channel 152) onto suture 131.

[0073] Next, as plunger 120 is fully depressed, follower pin 126 is translated from third cam channel portion 124c to fourth channel portion 124d. As follower pin 126 is translated from third cam channel portion 124c to fourth cam channel portion 124d, an audible/tactile indication is created, in the manner described above. As plunger 120 is fully depressed, actuating member 130 is fully translated in a distal direction to a distal-most portion of its stroke and ejecting clip 150 from the working tip 140. As clip 150 is fully ejected, suture 131 is captured between clip beam 151 and clip channel 152 of clip 150.

[0074] Finally, as shown in FIG. 8D, after clip 150 has been ejected from working tip 140 of clip applicer 100, clip 150 securely holds a suture 131 between clip channel 151 and clip beam 152.

[0075] Turning now to FIGS. 9-11, an embodiment of a suture clip 250 and a working tip 240 for a clip applier, according to another embodiment of the present disclosure, is shown and described. Working tip 240 has a substantially hook-like profile. In particular, with reference to FIG. 9, the hook-like profile of working tip 240 includes a transverse recess or notch 242 defined by a pair of coincident curved surfaces 242a, 242b, wherein recess 242 is angled or oriented so as to define a proximally extending hook 244. As shown in FIG. 9, working tip 240 further defines a longitudinally axially extending slot 246 configured and dimensioned to receive suture clip 250 therein.

[0076] As shown in FIG. 11, suture clip 250 has a substantially rectangular, flattened profile having a distal end portion and proximal end portion. Suture clip 250 includes a pair of spaced apart legs 252, 254 joined to one another by a crown or backspan 256. Legs 252, 254 are separated from one another to define a slot 258 therebetween. Each leg 252, 254 includes a respective angled surface 252a, 254a thereby defining a widened mouth or entry 258a of slot 258 for better receiving a suture 131 therein. A proximal end of slot 258 is dimensioned so as to cinch and retain suture 131 therein. Backspan 256 of suture clip 250 may have a generally V-shaped profile.

[0077] In use, as shown in FIGS. 9 and 10, with suture clip 250 loaded into slot 246 of working tip 240, such that mouth 258a of suture clip 250 is disposed proximal of notch 242 of working tip 240, a suture 131 is placed into notch 242 of working tip 240. Preferably, suture 131 is disposed at a base of notch 242. With suture 131 so positioned, an actuating member of the clip applier is manipulated to engage suture clip 250 and urge suture clip 250 in a distal direction. Suture clip 250 is translated distally such that suture is first received in mouth 258a and then advanced into the proximal end of slot 258 of suture clip 250. With suture clip 250

secured to suture 131, the actuation member of the clip applicator may be retracted and working tip 240 may be disengaged from suture clip 250.

[0078] Turning now to FIGS. 12 and 13, another embodiment of a suture clip, according to the present disclosure, is generally designated as suture clip 350. Suture clip 350 includes a leaf spring 351, a beam 352, and a lever 353. The leaf spring 351 is fixably attached to a proximal end 352b of beam 352 by, for example, a weld. Meanwhile, leaf spring 351 is fixably attached to a distal end 353a of lever 353 by, for example, a weld. Beam 352 defines a traverse groove 352c formed near distal end 353a and being configured to receive a suture therein. It is further contemplated that the attachment of beam 352 to lever 353 and leaf spring 351 may be achieved using a pin, staple, chemical adhesive or other attachment method known in the art.

[0079] As shown in FIG. 12, in its neutral configuration or at rest, leaf spring 351 maintains the distal ends 352a, 353a of beam 352 and lever 353 in contact with one another and maintains the proximal ends 352b, 353b of beam 352 and lever 353 separate from one another. With reference to FIG. 13, when a compressive force is applied to proximal ends 352b, 353b of beam 352 and lever 353, the distal ends 352c of beam 352 and lever 353 are separated from one another to open suture clip 350 and define a suture entry area 355. With suture clip 350 in an open condition, a suture 131 may be inserted through suture entry area 355 and captured into the suture retaining groove 352d of beam 352. Once the compressive force is removed, leaf spring acts on beam 352 and lever 353 to close the suture retaining area 355 and secure the suture therebetween.

[0080] Turning now to FIG. 14, yet another embodiment of a suture clip, according to the present disclosure, is generally designated as suture clip 450. Suture clip 450 includes a

backspan or crown 452 and a pair of spaced apart legs 454, 456 extending therefrom, with each leg 454, 456 being divided into a pair of spaced apart first and second legs 454a, 454b, and first and second legs 456a, 456b, respectively.

[0081] As seen in FIG. 14, first and second legs 454a, 454b of leg 454 are separated from one another by a relatively smooth longitudinally extending slot 454c. First and second legs 456a, 456b of leg 456 are separated from one another by a relatively smooth longitudinally extending slot 456c.

[0082] Further as seen in FIG. 14, first leg 454a of leg 454 and first leg 456a of leg 456 are separated from one another by a longitudinally extending slot 458 having an undulating or sinusoidal profile. Also, second leg 454b of leg 454 and second leg 456b of leg 456 are separated from one another by a longitudinally extending slot 460 having an undulating or sinusoidal profile.

[0083] Suture clip 450 further includes a pair of longitudinally extending channels 462, 464 formed in opposed outer surfaces thereof and extending along an entire length thereof. Each channel 462, 464 is defined by a pair of opposed ledges or shoulders 462a, 462b and 464a, 464b, respectively. Each ledge or shoulder 462a, 462b and 464a, 464b of respective channel 462, 464 includes a respective cam surface 463a, 463b (the cam surfaces of ledge or shoulder 464a, 464b not being visible in FIG. 14) projecting towards one another.

[0084] As shown in FIG. 14 and as can be appreciated by one skilled in the art, suture clip 450 may be used with a clip applicator that is configured to bias leg 454 and leg 456 apart from one another to receive a suture 131 therebetween. It is contemplated that as suture clip 450 is advanced in a distal direction relative to the clip applicator that legs 454, 456 may be biased apart

from one another as the cam surfaces 463a, 463b of legs 454b, 456b and the cam surfaces of legs 454a, 456a ride against a corresponding cam surface of the clip applier.

[0085] Although the illustrative embodiments of the present disclosure have been described herein with reference to the accompanying drawings, it is to be understood that the disclosure is not limited to those precise embodiments, and that various other changes and modifications may be effected therein by one skilled in the art without departing from the scope or spirit of the disclosure.

[0086] Those skilled in the art, having the benefit of the teachings of the present invention as herein and above set forth, may effect modifications thereto. Such modifications are to be construed as lying within the scope of the present invention, as defined by the appended claims.

[0087] Although specific features of the suture clip applier are shown in some of the drawings and not in others, this is for convenience only as each feature may be combined with any or all of the other features in accordance with the aspects of the present disclosure. Other embodiments will occur to those skilled in the art and are within the following claims.

[0088] It is to be understood that the illustrated embodiments are for the purpose of example, and that numerous other configurations of wound dressing systems having a plurality of beads exist. Accordingly, the illustrated and described embodiments are not intended to limit the scope of the inventive subject matter only to those embodiments.

The embodiments of the present invention for which an exclusive property or privilege is claimed are defined as follows:

1. A suture clip for selective attachment to a suture, the suture clip comprising:

an elongated flexible beam having a distal end portion, a proximal end portion, a top surface and a bottom surface, the flexible beam further including a pair of arms extending laterally therefrom; and

an elongated rigid channel, wherein the elongated rigid channel has a substantially U-shaped transverse cross-sectional profile with a horizontal base wall and vertical side walls having a distal end portion and proximal end portion, wherein each vertical side wall defines a holding step formed in an upper edge thereof;

wherein the flexible beam and the channel are coupled to one another at their proximal end portions; and

wherein the pair of arms of the flexible beam are in registration with a corresponding holding step formed in the upper edge of the vertical side walls.

2. The suture clip according to claim 1, wherein a proximal end portion of the pair of vertical side walls of the channel of the suture clip include inwardly projecting lips for retaining the proximal end portion of the beam within the channel.

3. The suture clip according to claim 1, wherein the proximal end portions of the beam and channel are adhesively coupled to one another.

4. The suture clip according to any one of claims 1 to 3, wherein the pair of arms project beyond the pair of vertical side walls of the channel.

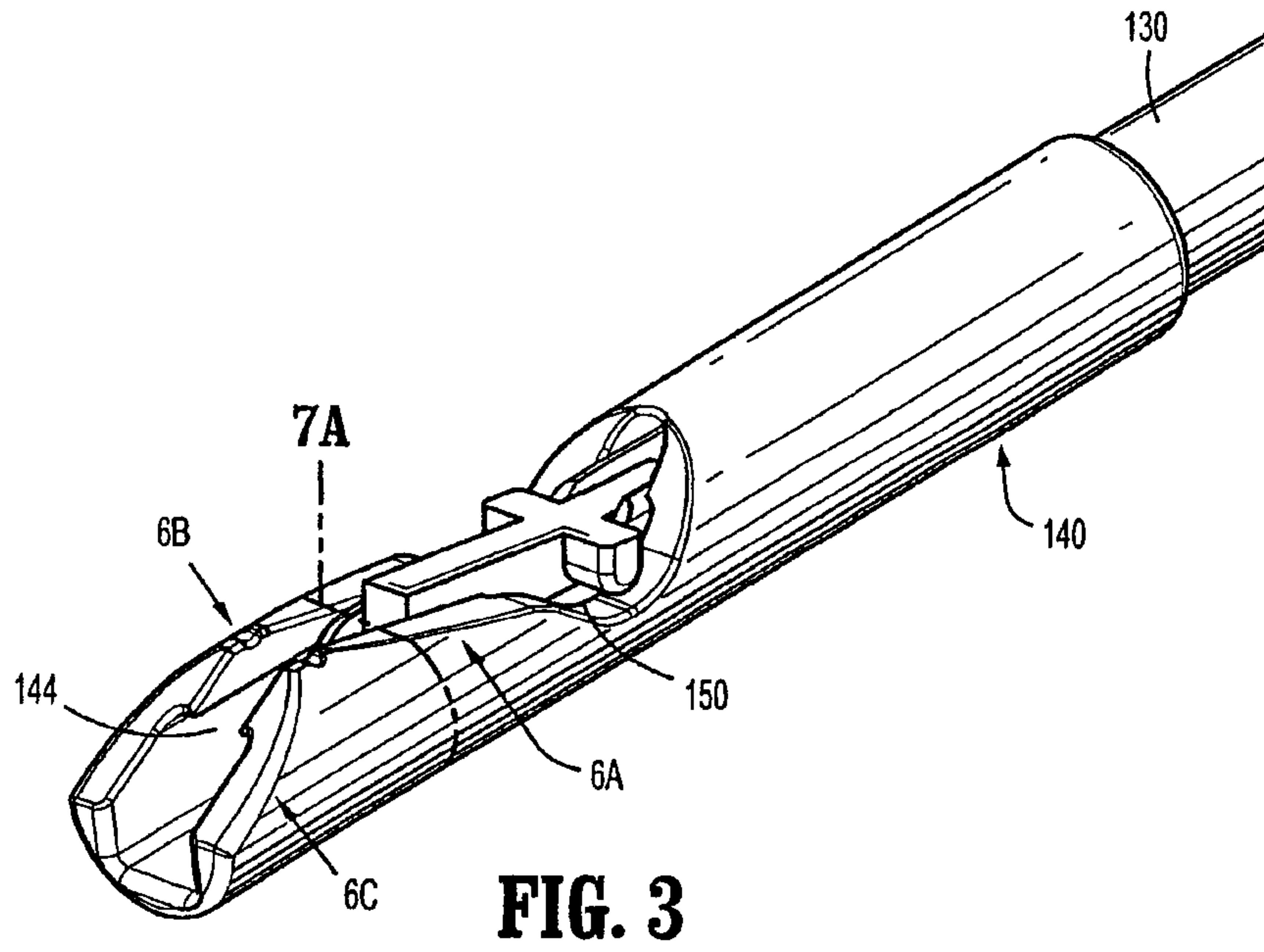
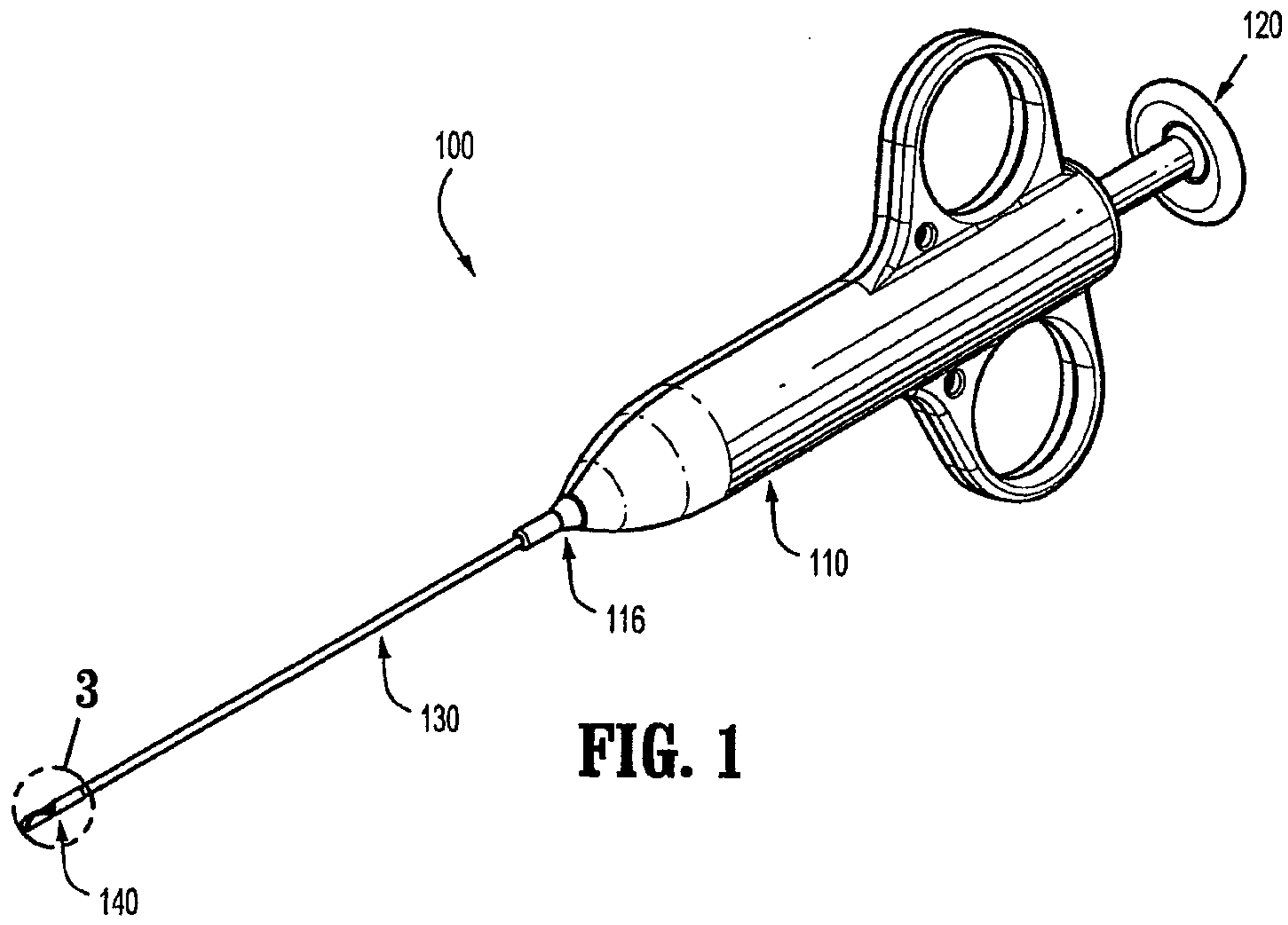

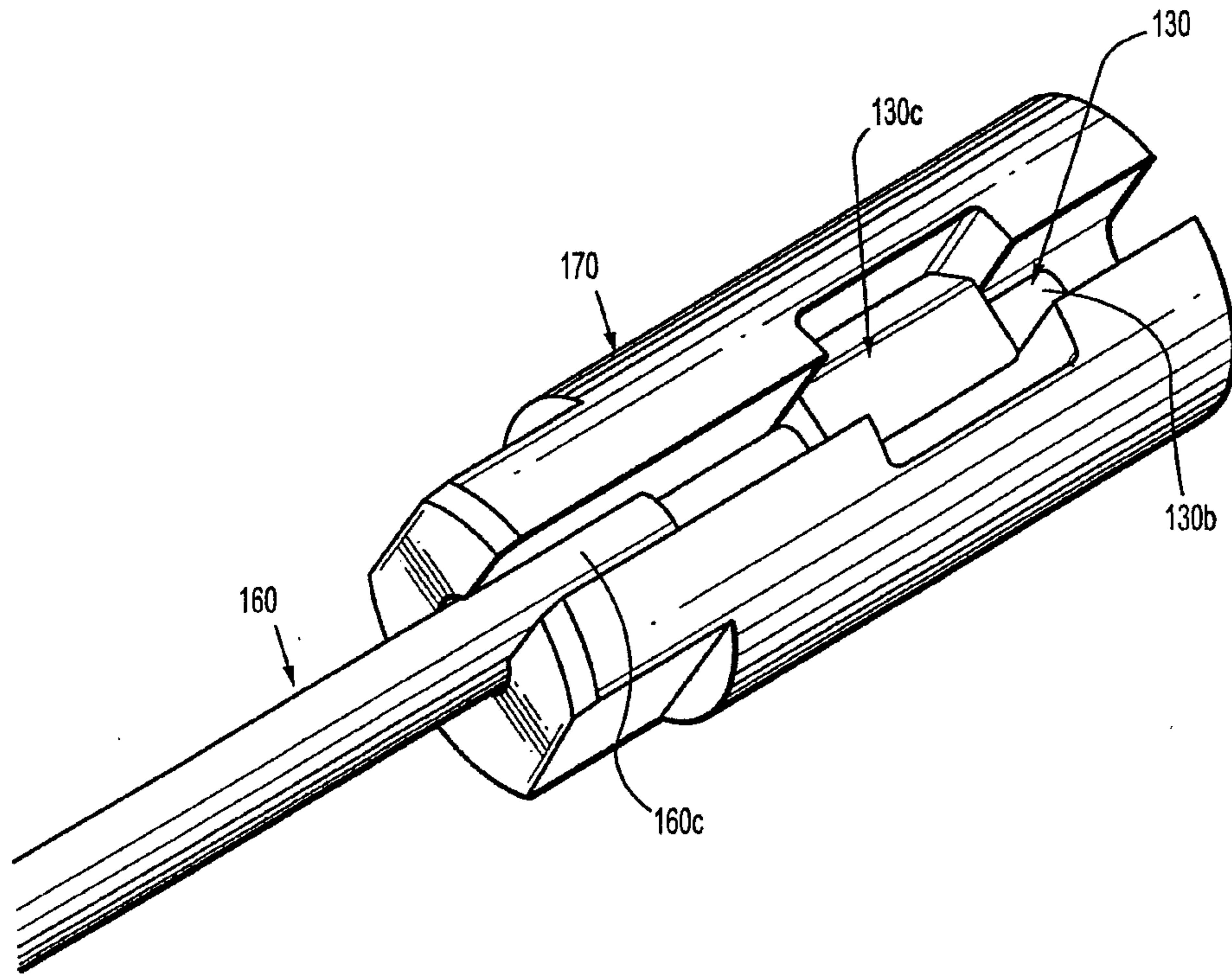
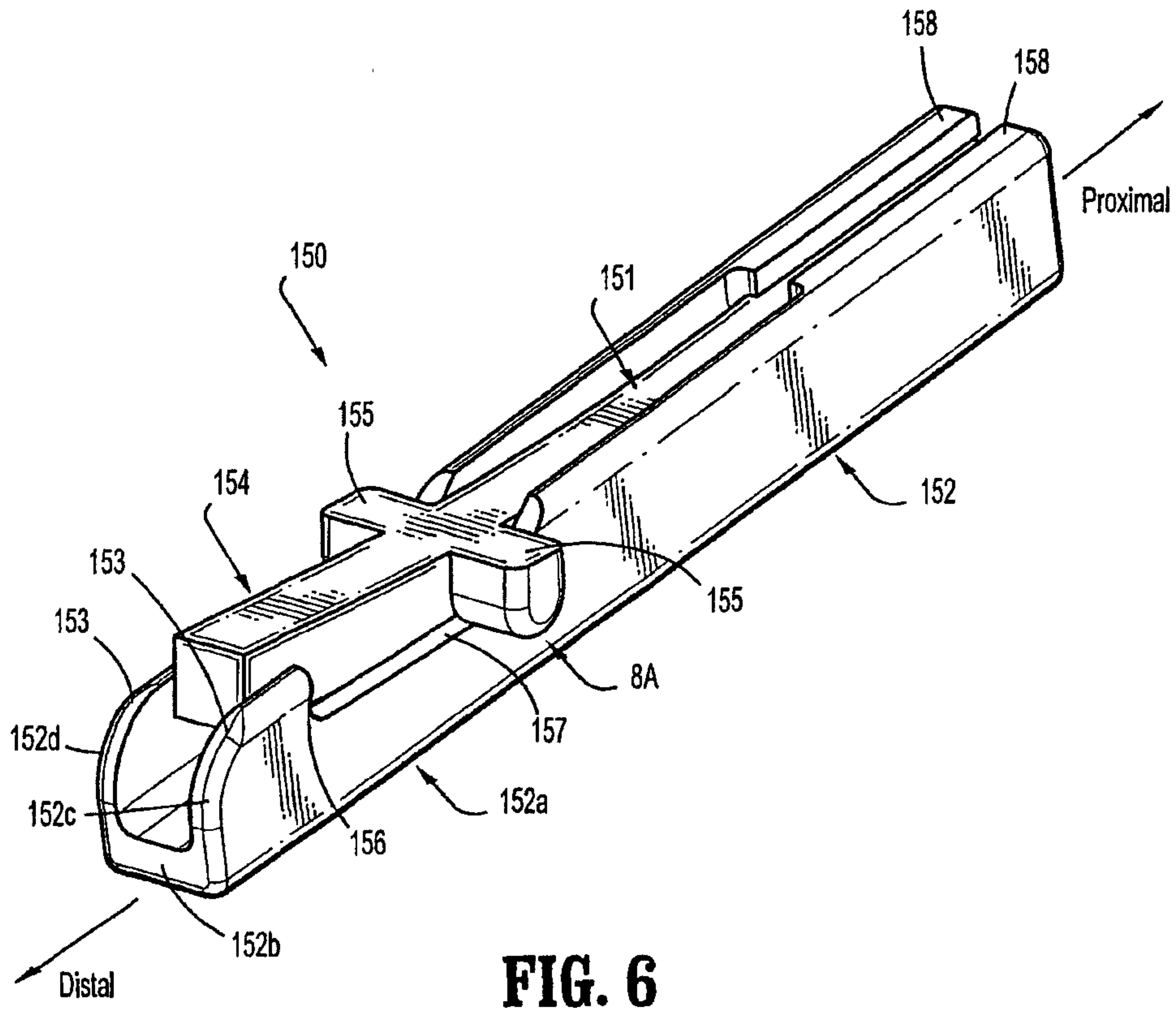

FIG. 2A



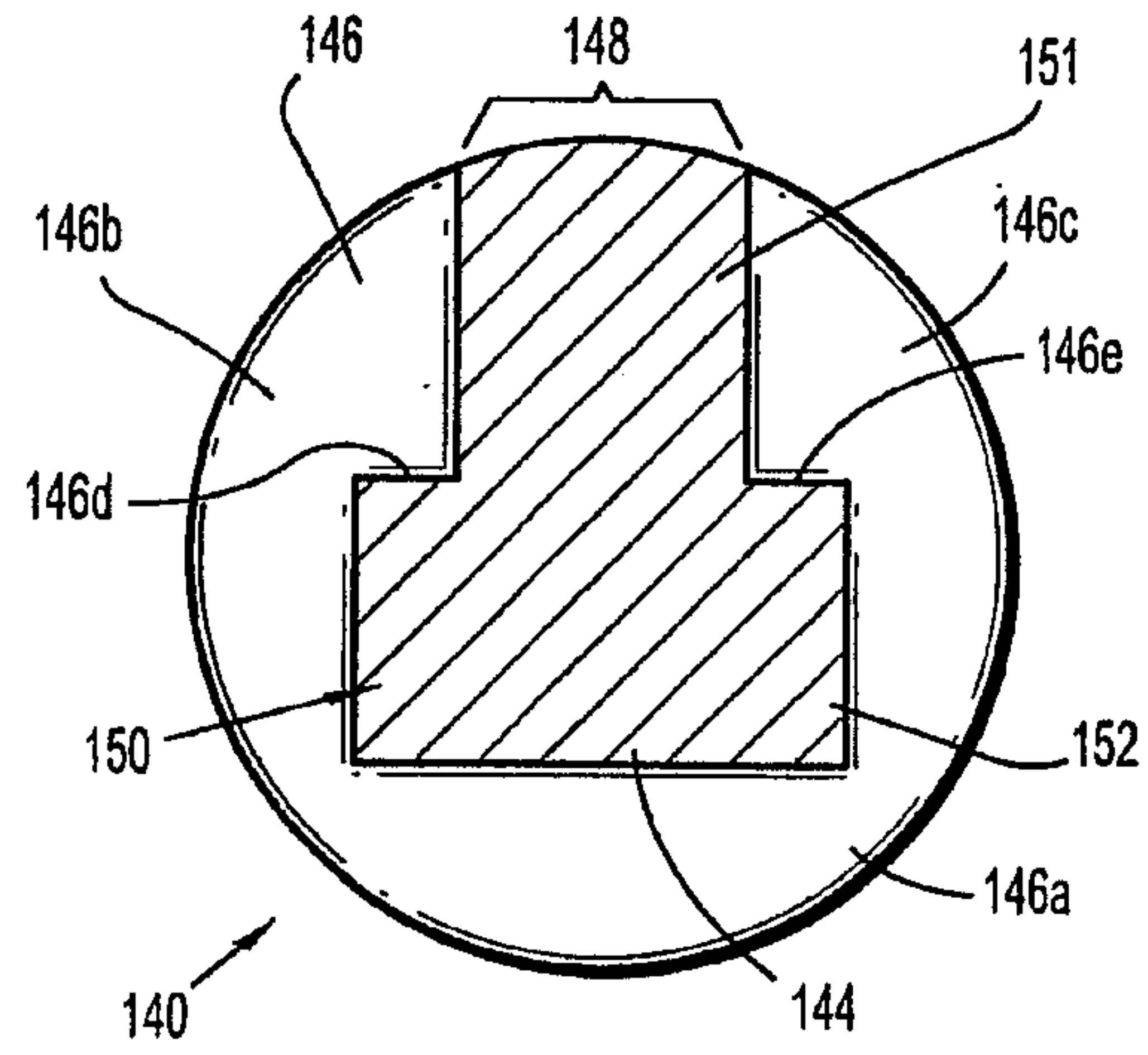

FIG. 7A

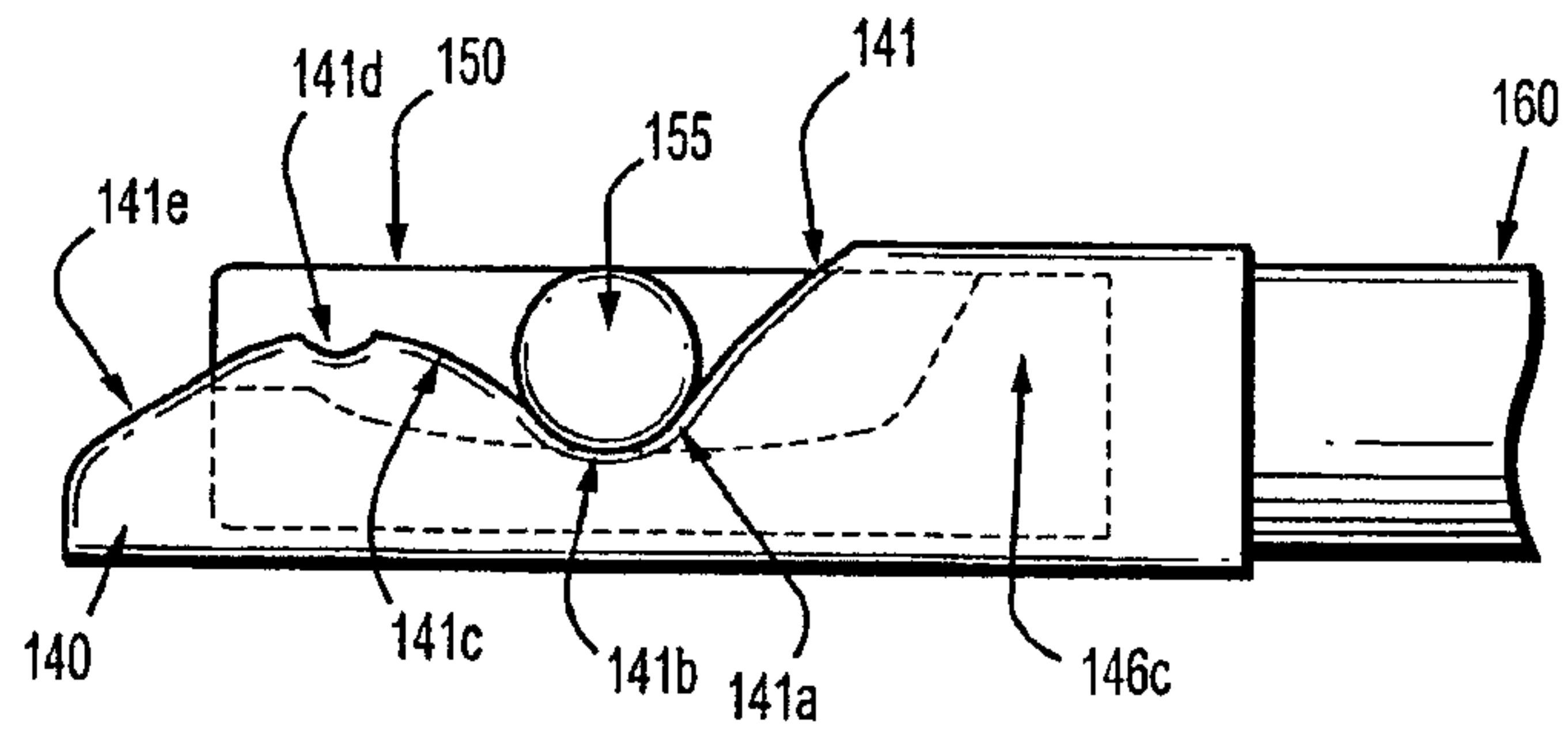

FIG. 7B

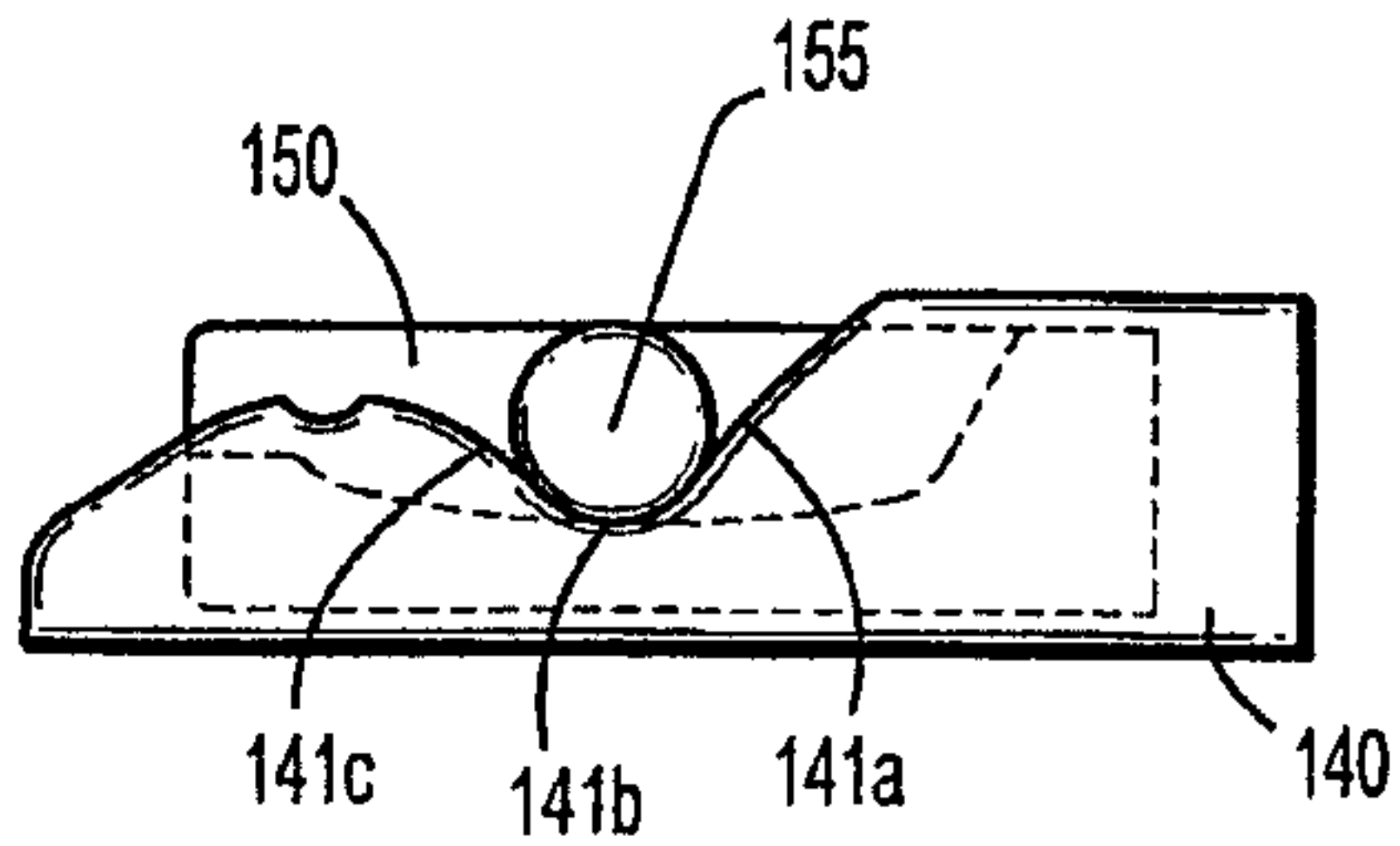

FIG. 8A

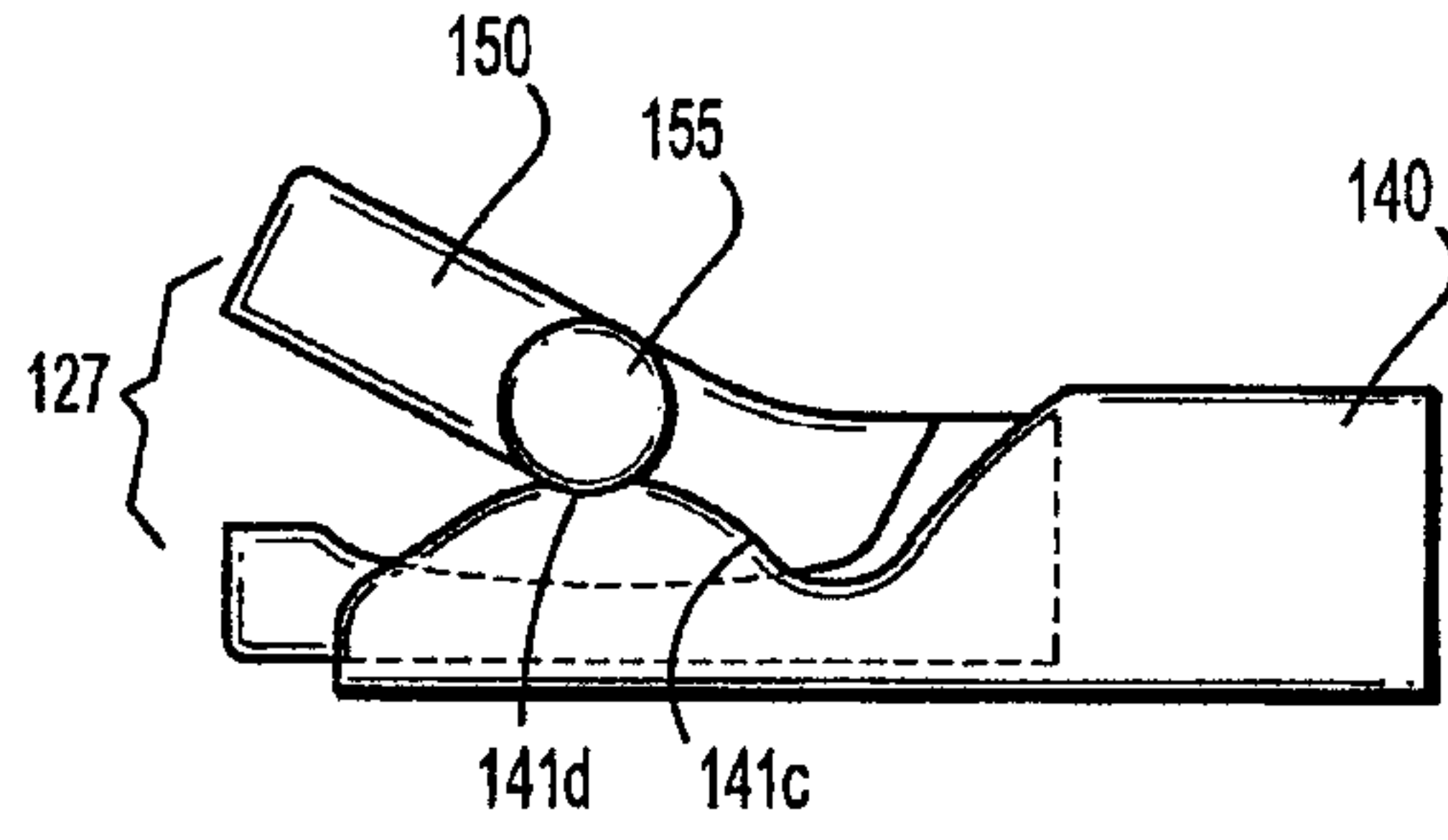

FIG. 8B

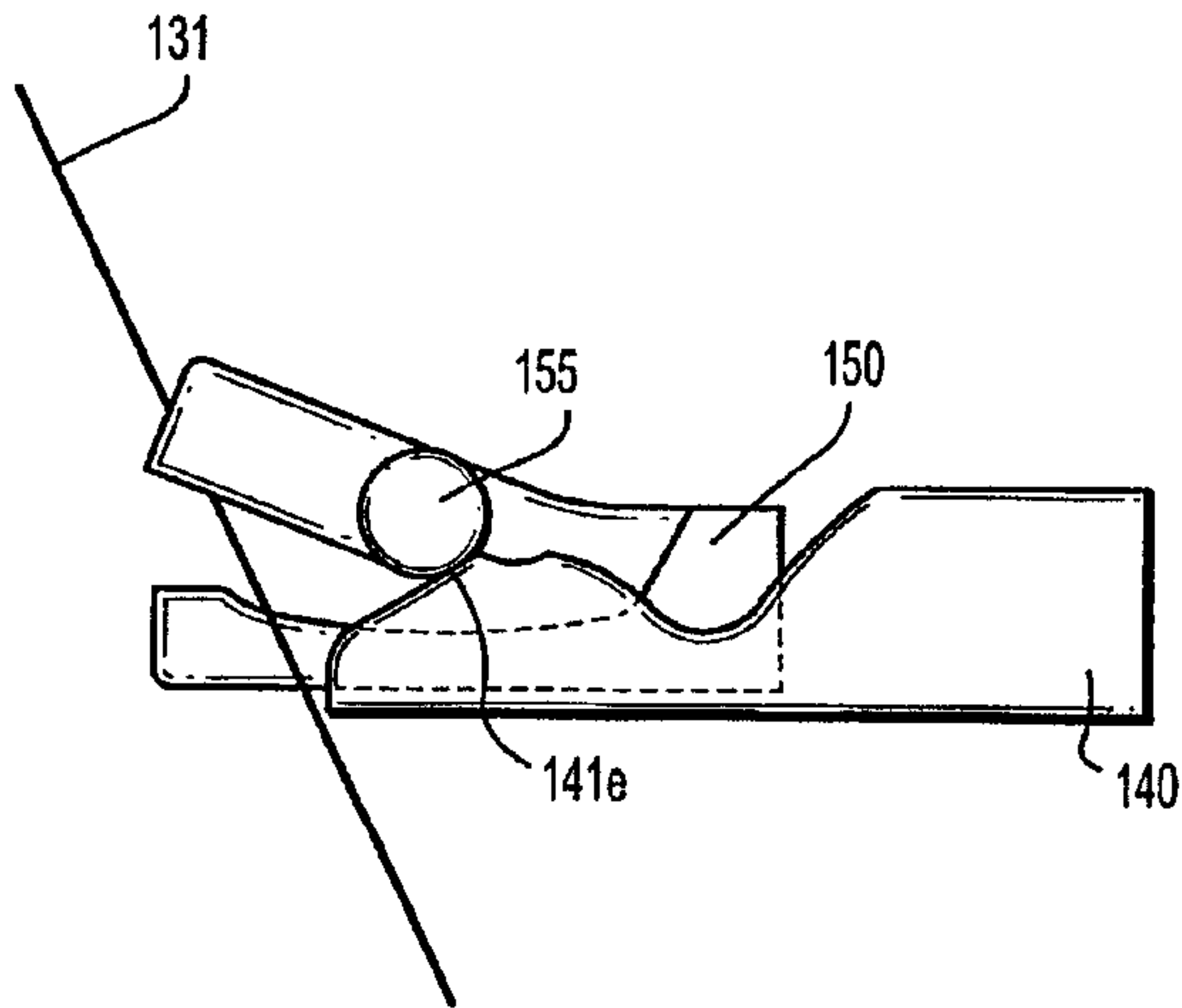

FIG. 8C

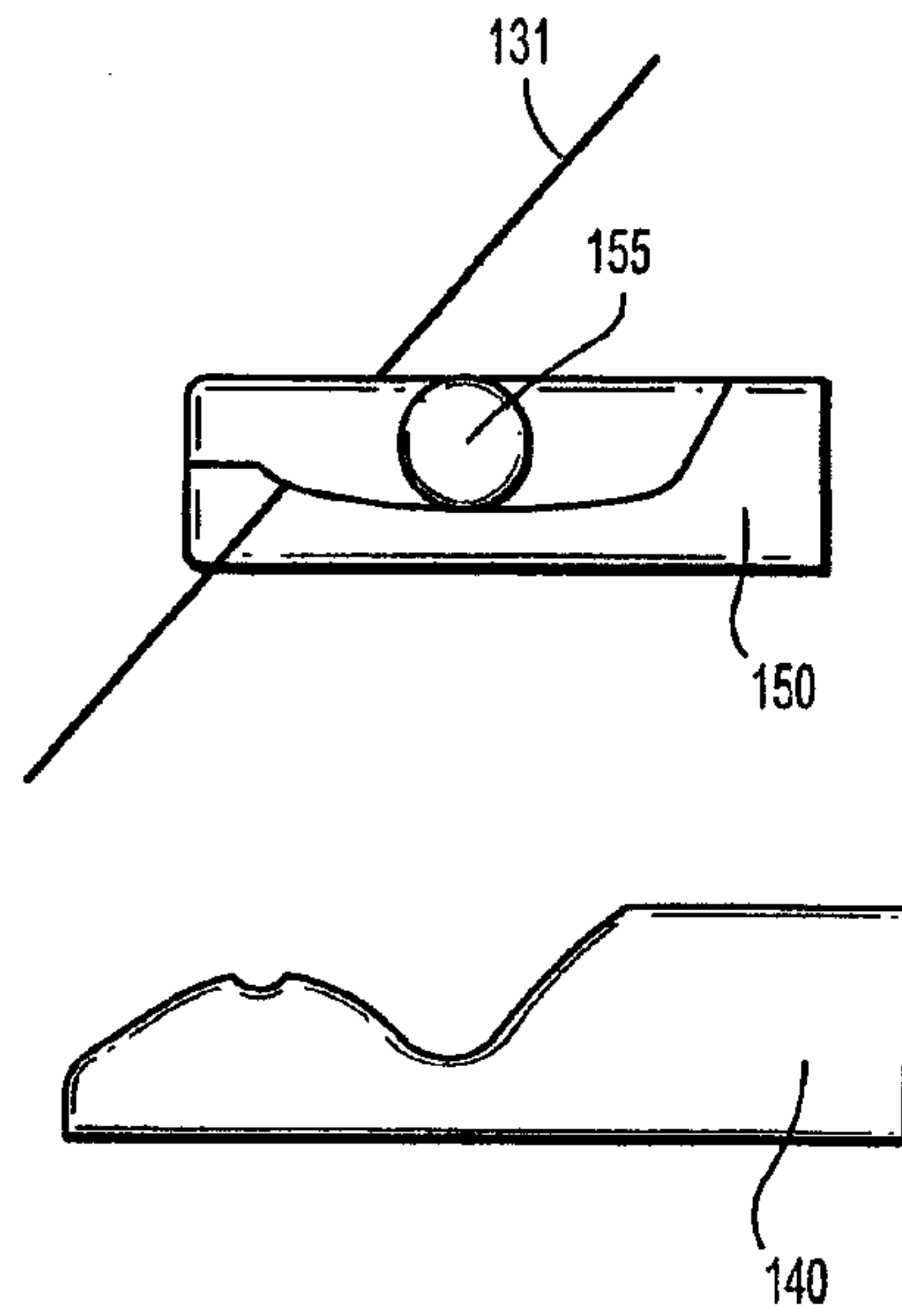
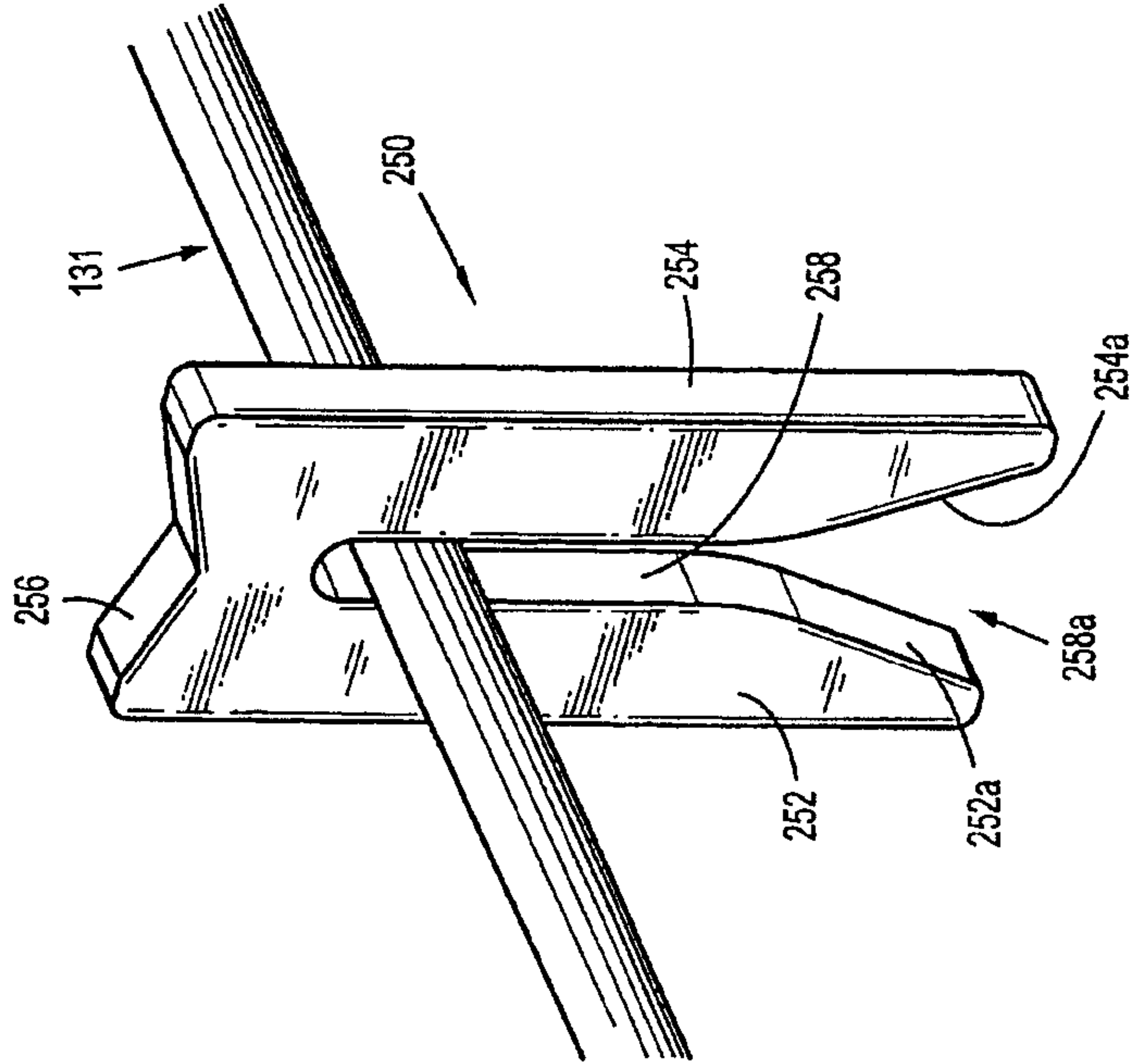
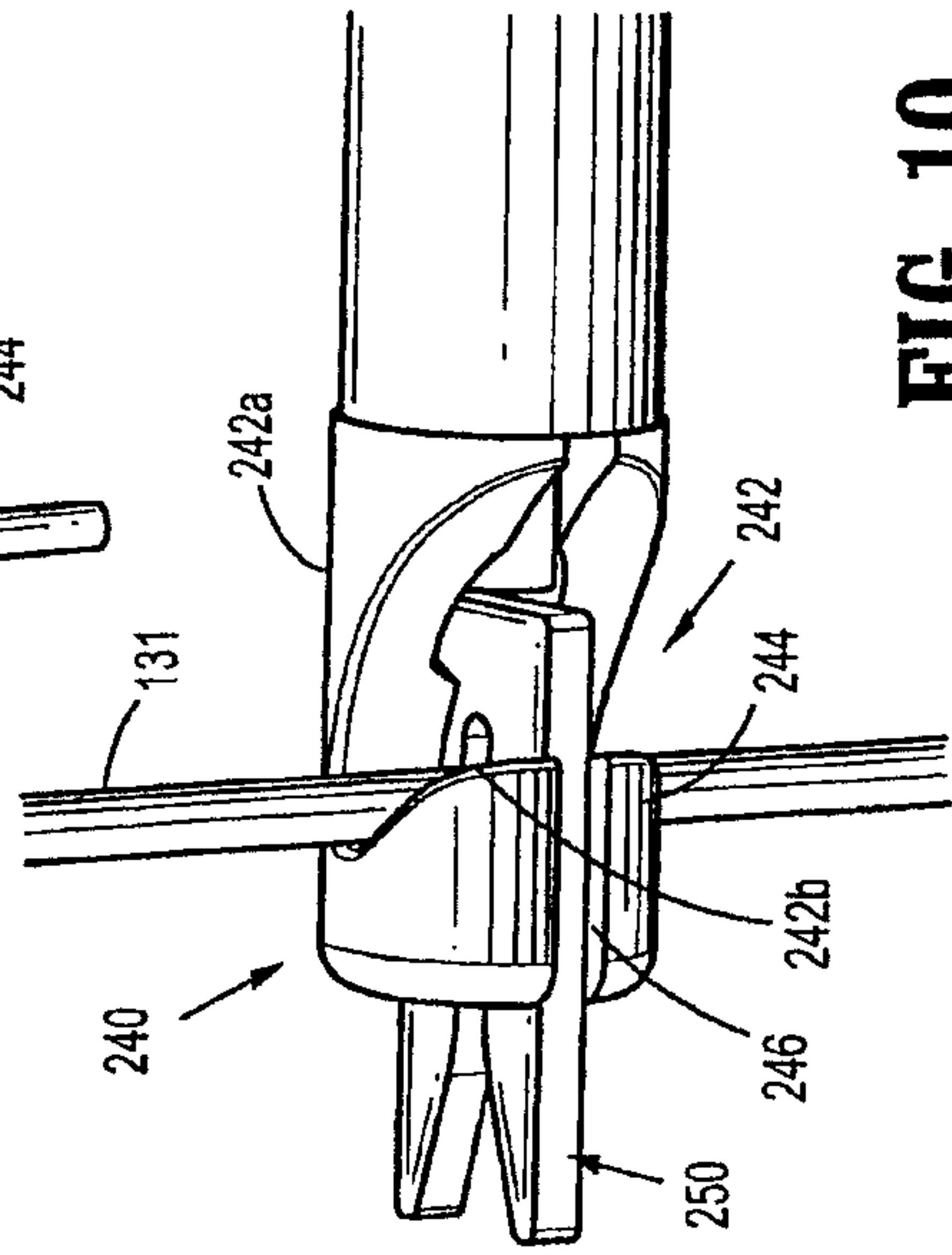
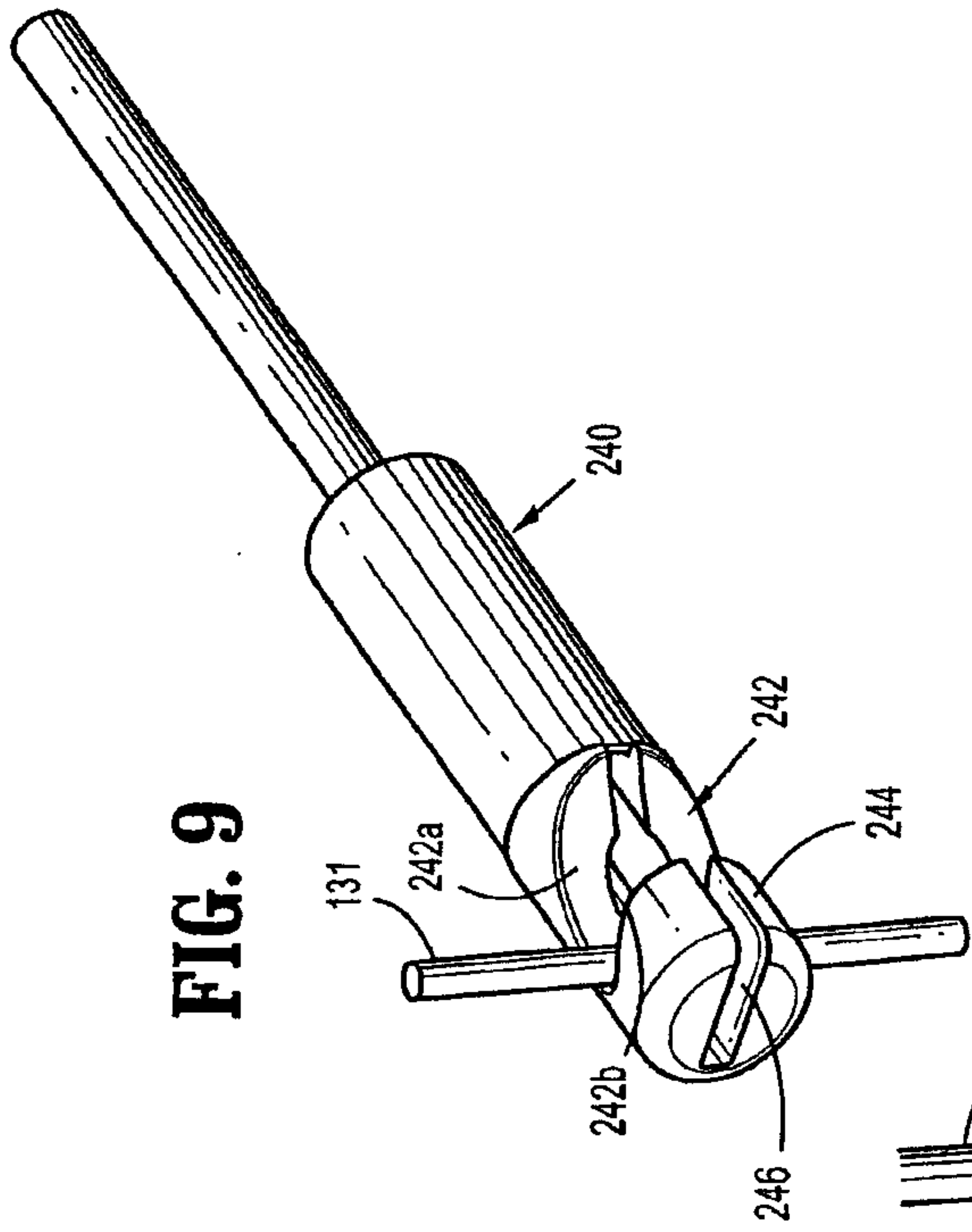

FIG. 8D



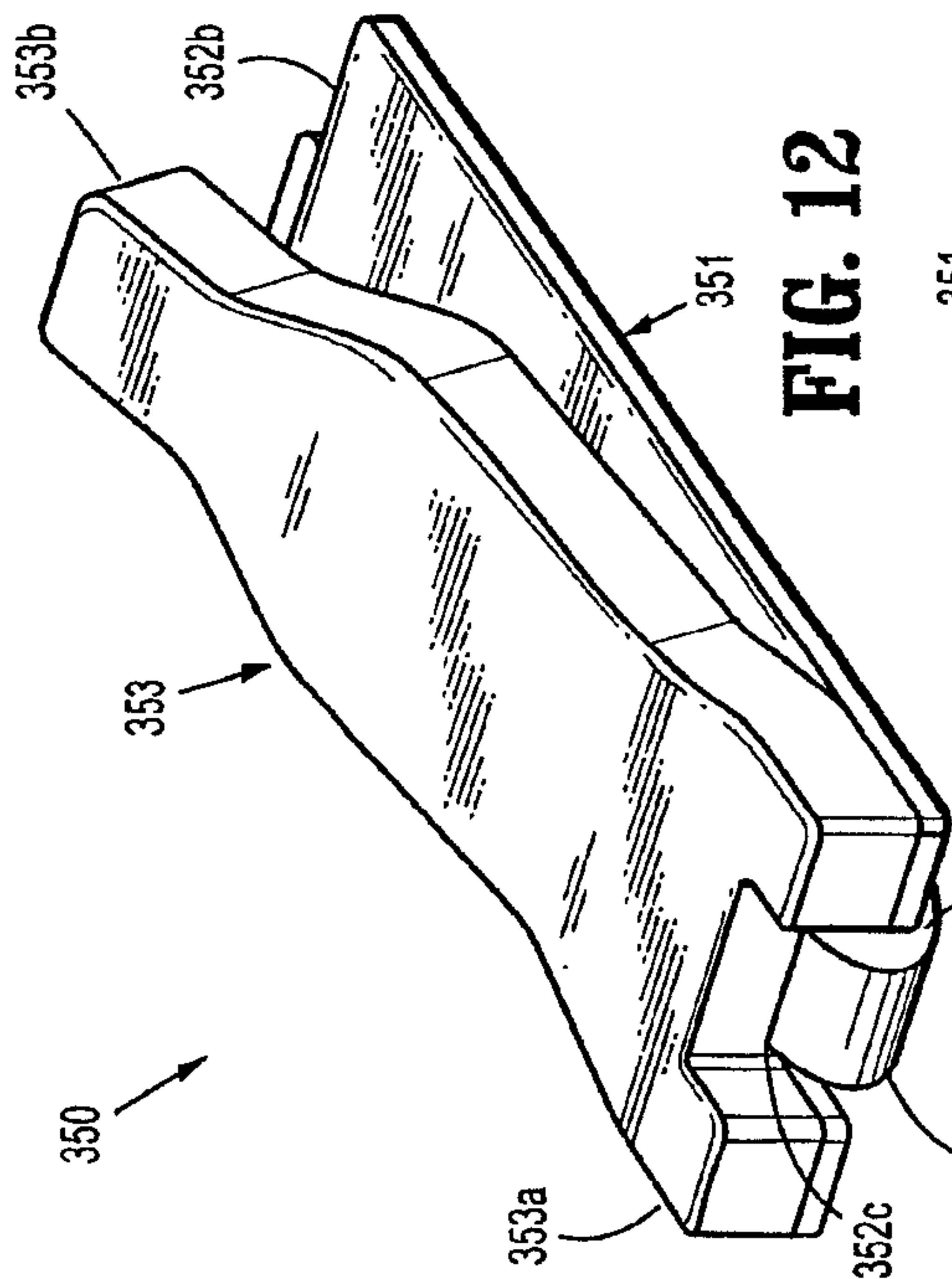

FIG. 12

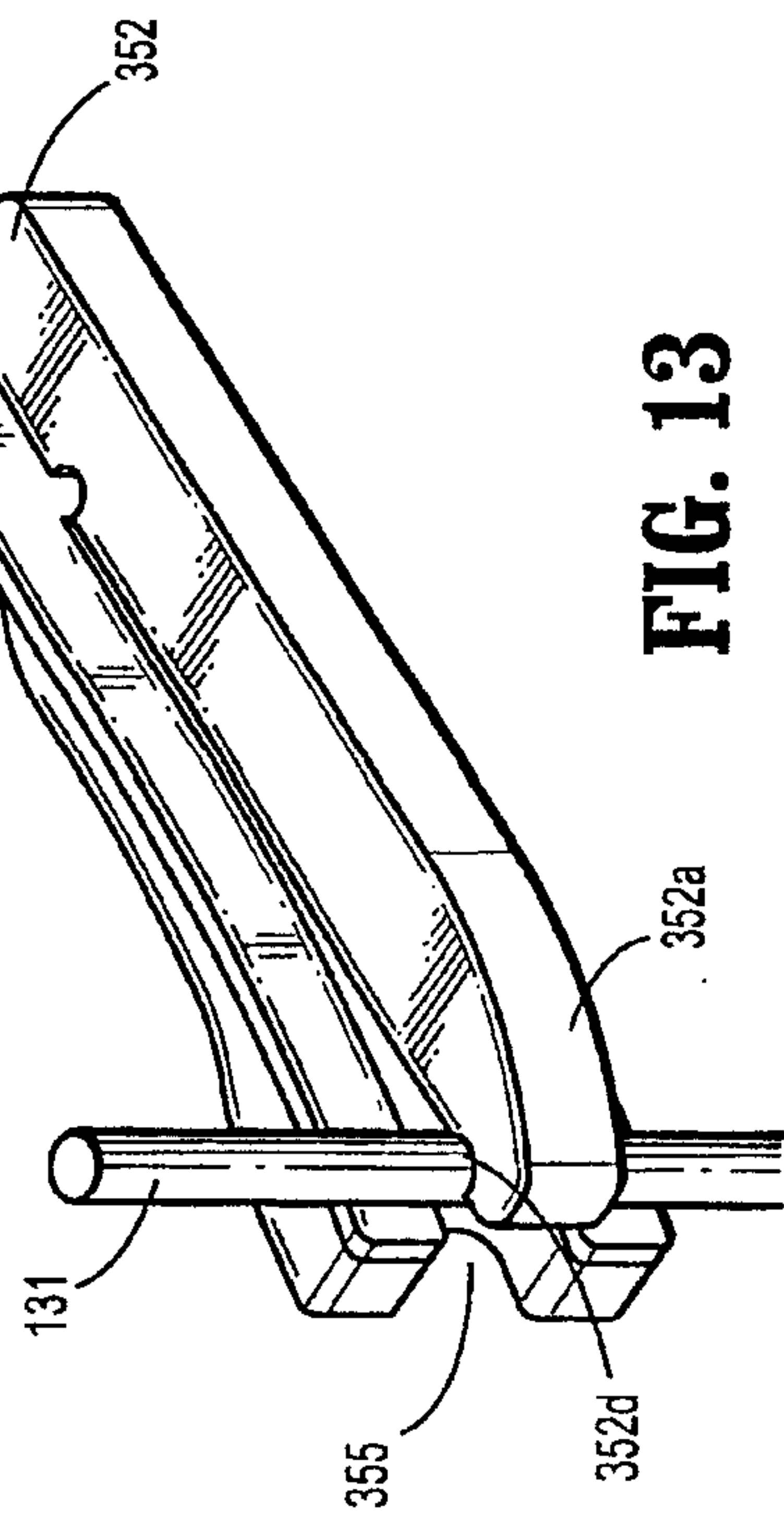

FIG. 13

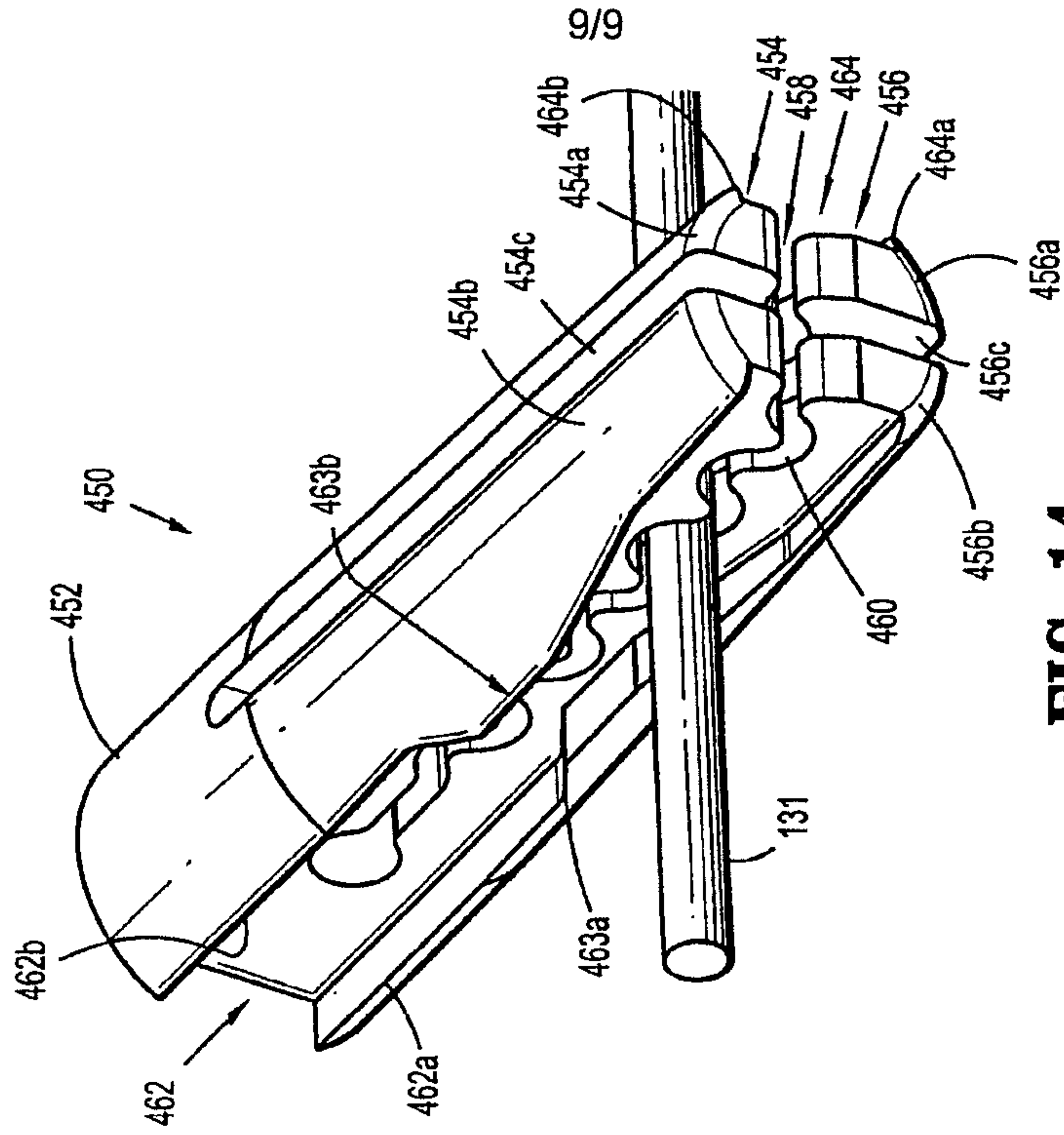

FIG. 14

