

Published:

— with international search report (Art. 21(3))

— before the expiration of the time limit for amending the claims and to be republished in the event of receipt of amendments (Rule 48.2(h))

TITLE OF THE INVENTION

FACET INTERFERENCE SCREW

CROSS-REFERNCE TO RELATED APPLICATIONS

[0001] This application claims the benefit of U.S. Provisional Application No. 61/034,295, filed on March 6, 2008, entitled "FACET INTERFERENCE SCREW," the contents of which is incorporated in its entirety by reference herein.

BACKGROUND OF THE INVENTION

[0002] The facet joint is an articulating joint of a spinal motion segment that can degenerate during aging, trauma, typical use and other factors. The facet joints in various regions of the spine are oriented in different planes, for example, the lumbar facet joints are generally located in the sagittal plane S_P , the thoracic facet joints are generally oriented in the coronal plane C_P and the cervical facet joints are generally oriented in the axial or transverse plane A_P (Figs. 1 and 2). These orientations facilitate different types of motion in the respective regions of the spine.

[0003] Degenerated facet joints are often painful as a result of, for example, wear between two arthritic articulating surfaces that surround the synovial joint capsule. The surfaces of the facet joints are covered by articular cartilage. Inflammatory reactions may occur when the cartilaginous surfaces of the facets become degraded or fissured, thereby leading to direct bone-on-bone contact and resulting in pain. Over distraction of the surrounding joint capsules may also cause pain to the patient. Patients typically undergo a fusion surgery to alleviate this pain.

[0004] It is desirable to develop an implant for insertion into the facet joints between adjacent superior and inferior vertebrae to alleviate pain resulting from degenerating facet joints that may not result in immediate fusion of the facet joint.

BRIEF SUMMARY OF THE INVENTION

[0005] The present invention relates to a spinal implant. More specifically, a preferred embodiment of the present invention relates to a facet interference screw for insertion between the facet joints of adjacent superior and inferior vertebrae. The facet interference screw preferably includes a head portion and an externally threaded shaft portion so that the facet interference screw can be rotatively inserted or screwed into the facet joint via an insertion instrument such as, for example, a screw driver or screw driver-like instrument. The facet interference screw preferably includes first and second components such that each of the first and second components includes an outer, semicircular externally threaded surface and an inner surface so that when coupled together the semicircular externally threaded surfaces form an externally threaded shaft portion.

[0006] In a preferred embodiment, the inner surfaces of the first and second components may include curved contacting surfaces. The curved contacting surfaces preferably permit an arcuate movement between the first and second components along a longitudinal axis and limited movement lateral to the longitudinal axis.

[0007] In another preferred embodiment of the facet interference screw, a damping component may be inserted between the inner surfaces of the first and second components to facilitate damping of the first and second components with respect to one

another. The damping component may be in the form of a two-piece damping component including an upper damping component having an outer surface for contacting the inner surface of the first component and an inner surface. The damping component may also include a lower damping component having an outer surface for contacting the inner surface of the second component and an inner surface. The inner surfaces of the upper and lower damping components each include a curved contacting surface so that the upper damping component is articulatable with respect to the lower damping component. The upper damping component is preferably fixed to the first component and the lower damping component is preferably fixed to the second component such that a majority of the articulation of the facet interference screw is between the upper and lower damping components at the curved contacting surfaces of the upper and lower damping components.

[0008] The present invention is also related a method for inserting the preferred facet interference screw between the facet joints of adjacent superior and inferior vertebrae.

BRIEF DESCRIPTION OF THE DRAWINGS

[0009] The foregoing summary, as well as the following detailed description of preferred embodiments of the application, will be better understood when read in conjunction with the appended drawings. For the purposes of illustrating the preferred facet interference screw and surgical method for inserting the facet interference screw of the present application, there are shown in the drawings preferred embodiments. It should be understood, however, that the application is not limited to the precise arrangements and instrumentalities shown. In the drawings:

[0010] Fig. 1A illustrates a rear perspective view of two facet interference screws mounted in facet joints in a mounted position in a lumbar portion of a patient's spine in accordance with one of the below-described preferred embodiments of the present invention;

[0011] Fig. 1B illustrates a side perspective view of the facet interference screws in the mounted position shown in Fig. 1A;

[0012] Fig. 2A illustrates a side perspective view of a facet interference screw according to a first preferred embodiment of the present invention;

[0013] Fig. 2B illustrates an exploded, side perspective view of the facet interference screw shown in Fig. 2A;

[0014] Fig. 2C illustrates a side perspective view of the facet interference screw shown in Fig. 2A, with a temporary spacer;

[0015] Fig. 3A illustrates a top perspective view of a facet interference screw according to a second preferred embodiment of the present invention;

[0016] Fig. 3B illustrates a top perspective view of a damping component that may be used in connection with the facet interference screw shown in Fig. 3A, the damping component including a cannulated opening therethrough;

[0017] Fig. 3C illustrates a top perspective view of an alternate damping component that may be used in connection with the facet interference screw shown in Fig. 3A, the damping component being generally solid and continuous;

[0018] Fig. 3D illustrates a top perspective view of yet another alternate damping component that may be used in connection with the facet interference screw shown in Fig. 3A, the damping component including a T-shaped channel for engaging a groove

formed in one or both of a first component and a second component of the facet interference screw of Fig. 3A;

[0019] Fig. 4A illustrates a side perspective view of a facet interference screw according to a third preferred embodiment of the present invention;

[0020] Fig. 4B illustrates a side perspective view of an exemplary two-piece articulating component that may be used in connection with the facet interference screw shown in Fig. 4A;

[0021] Fig. 5A illustrates a cross-sectional view of the facet interference screw shown in Fig. 4A taken along line 5-5 of Fig. 4A, the facet interference screw shown in a neutral position;

[0022] Fig. 5B illustrates a cross-sectional view of the facet interference screw shown in Fig. 4A taken along line 5-5 of Fig. 4A, the facet interference screw shown undergoing flexion;

[0023] Fig. 5C illustrates a cross-sectional view of the facet interference screw shown in Fig. 4A taken along line 5-5 of Fig. 4A, the facet interference screw shown undergoing extension;

[0024] Fig. 6A illustrates a rear elevational view of the facet interference screw shown in Fig. 4A, the facet interference screw shown in a neutral position;

[0025] Fig. 6B illustrates a rear elevational view of the facet interference screw shown in Fig. 4A, the facet interference screw shown undergoing lateral bending;

[0026] Fig. 7A illustrates a rear perspective view of one of the above-described facet interference screws of the first, second and third preferred embodiments including a preferred anti-rotational mechanism;

[0027] Fig. 7B illustrates a rear perspective view of one of the above-described facet interference screws of the first, second and third preferred embodiments including an alternative preferred anti-rotational mechanism;

[0028] Fig. 8 illustrates a rear perspective view of two facet interference screws in accordance with at least one of the first, second and third preferred embodiments being simultaneously inserted into facet joints of a patient's spine in accordance with a preferred method of the present invention;

[0029] Fig. 9A illustrates a top perspective view of the facet interference screw of Fig. 4A mounted to a preferred screw driver, wherein a preferred sleeve, shown in phantom, of the screw driver is in an extended position;

[0030] Fig. 9B illustrates a top perspective view of the facet interference screw of Fig. 4A, taken from within circle 9B of Fig. 9A;

[0031] Fig. 9C illustrates a side perspective view of the facet interference screw of Fig. 4A mounted to the screw driver with the sleeve in a retracted position; and

[0032] Fig. 9D illustrates an enlarged top perspective view of the facet interference screw of Fig. 4A mounted to the screw driver with the sleeve in a further retracted position.

DETAILED DESCRIPTION OF THE INVENTION

[0033] Certain terminology is used in the following description for convenience only and is not limiting. The words "right", "left", "top" and "bottom" designate directions in the drawings to which reference is made. The words "inwardly" and "outwardly" refer to directions toward and away from, respectively, the geometric center of the facet interference screw and designated parts thereof. The words, "anterior", "posterior",

“superior”, “inferior”, “lateral”, “sagittal”, “axial”, “coronal” and related words and/or phrases designate preferred positions and orientations in the human body to which reference is made and are not meant to be limiting. The terminology includes the above-listed words, derivatives thereof and words of similar import.

[0034] Certain exemplary embodiments of the invention will now be described with reference to the drawings. Preferred embodiments of the present invention are directed to (i) first, second and third preferred embodiments of a facet interference screw 10, 10', 10'' for insertion between facet joints FJ of adjacent superior and inferior vertebrae V and (ii) an exemplary surgical method for inserting the preferred facet interference screws 10, 10', 10'' between the facet joints FJ of adjacent superior and inferior vertebrae V in a patient's spine. It should be appreciated that while the preferred facet interference screws 10, 10', 10'' of the present application will be described as and may generally be used in the spine (for example, in the lumbar, thoracic or cervical regions), one of ordinary skill in the art will understand that the preferred facet interference screws 10, 10', 10'', as well as the components thereof, may be used in other parts of the body including, for example, the knee, hip, shoulder, finger, joints, long bones or bones in the hand, face, feet, including, for example, metacarpal, trapezoidal, and scaphoidal joints of the hand and metatarsal-phalanges joints in the feet, *etc.*

[0035] Referring to Figs. 1A and 1B, two exemplary vertebrae V in the lumbar region of a patient's spine are shown. The vertebrae V each include a pair of superior articular facets F_S and a pair of inferior articular facets F_i on either side of the spinous process SP. The inferior facet F_i on the superior vertebra V and the superior facet F_S on the inferior vertebra V are movably interconnected via a joint capsule or facet joint space FJ_1, FJ_2 that

guide and limit motion of the motion segment. The vertebrae V shown in Figs. 1A and 1B include a first facet joint FJ₁ positioned to a left-side of the spinous process SP and a second facet joint FJ₂ positioned to a right-side of the spinous process S_P. The first and second facet joints FJ₁, FJ₂ include first and second facet joint planes FJ_{P1}, FJ_{P2}, respectively, that are generally oriented in the sagittal plane S_P in a majority of the lumbar spine.

[0036] The facet joints FJ₁, FJ₂ guide and facilitate movement between the superior and inferior vertebrae V. As a result of natural or traumatic degeneration of the spine S, the facet joints FJ₁, FJ₂ may be affected. For example, an inflammatory reaction may occur when the cartilaginous surfaces of the facet joints FJ₁, FJ₂ are degraded, which may lead to direct contact between the inferior facet F_I formed on the superior vertebra V and the superior facet F_S formed on the inferior vertebra V, resulting in pain in the facet joints FJ₁, FJ₂.

[0037] Augmentation of the facet joints FJ₁, FJ₂ to alleviate pressure on the painful area may be achieved via the insertion of an implant, preferably a preferred facet interference screw 10, 10', 10'', between the inferior facet F_I formed on the superior vertebra V and the superior facet F_S formed on the inferior vertebra V. The preferred facet interference screw 10, 10', 10'' allows for the treatment of the facet joints FJ₁, FJ₂, permitting preservation of mobility and/or stabilization while enabling the pedicles to remain intact if additional internal fixation is required at any time. Augmentation of the facet joints FJ₁, FJ₂ may be achieved via the insertion of two preferred facet interference screws 10, 10', 10'', one for each of the facet joints FJ₁, FJ₂. In addition, the preferred

facet interference screw 10, 10', 10'' may be inserted with or without insertion of a spacer within the intervertebral disk space D_S between the adjacent vertebrae V.

[0038] Referring to Figs. 2A and 2B, a first preferred embodiment of the facet interference screw 10 is generally in the form of a bone screw 10. The facet interference screw 10 of the first preferred embodiment includes a head portion 14 and an externally threaded shaft portion 16. The head portion 14 preferably includes a mechanism for engaging a screwdriver 225. For example, the head portion 14 preferably includes a plurality of recesses 44 for engaging a plurality of projections 229 formed on a tip 228 of the screwdriver 225 (as will be described in greater detail below), although other configurations are envisioned, including but not limited to, an internal recess, an external hexagon, a star drive pattern, a Phillips head pattern, a slot for a screw driver, a threading for a correspondingly threaded post, *etc.* The specific features of the shaft 16 including, for example, thread pitch, self drilling configurations, self tapping configurations, shaft diameter, shaft shape, *etc.* are interchangeable, and it would be apparent to one having ordinary skill in the art that the facet interference screw 10 is not limited to any particular type of shaft 16 or thread configuration.

[0039] The facet interference screw or bone screw 10 of the first preferred embodiment is split longitudinally along a longitudinal axis 13 of the facet interference screw 10, such that the facet interference screw 10 includes a first component 20 and a second component 30. Each of the first and second components 20, 30 includes an outer, preferably semicircular externally threaded surface 22, 32 and an inner surface 24, 34, so that when coupled together the semicircular externally threaded surfaces 22, 32 form the externally threaded shaft portion 16. Thus, in use, the facet interference screw 10 is

preferably inserted between the inferior facet F_i formed on the superior vertebra V and the superior facet F_s formed on the inferior vertebra V via rotation by, for example, a screw driver 225, as will be described in greater detail below. The inner surfaces 24, 34 of the first preferred embodiment preferably extend, generally continuously, from the head portion 14 to a tip 16a of the shaft portion 16 and define an articulation plane RP generally along which the first and second components 20, 30 may move relative to each other in a mounted position, as will be described in greater detail below. The inner surfaces 24, 34 are preferably in contact along a substantial portion thereof in an assembled configuration and in the mounted configuration to guide and movement of the first component 20 relative to the second component 30.

[0040] The inner surfaces 24, 34 of the first and second components 20, 30 of the facet interference screw 10 of the first preferred embodiment may include curved contacting surfaces having, for example, a convex and/or concave surface for interacting with the curved contacting surface of the other component 20, 30, respectively, so that when inserted, the first component 20 is movable along a curved or arcuate path with respect to the second component 30. That is, for example, the inner surface 24 of the first component 20 may include a convex surface for contacting a concave surface formed on the inner surface 34 of the second component 30. Although as will be appreciated by one of ordinary skill in the art, the inner surface 34 of the second component 30 may have a convex surface while the inner surface 24 of the first component 20 may have a concave surface. Alternatively, both inner surfaces 24, 34 may have a concave surface or a convex surface. The convex or concave shape of the inner surfaces 24, 34 resulting in the arcuate path of movement between the first and second components are preferably

mounted in one of the facet joints FJ_1 , FJ_2 in a mounted position to generally mimic the natural arcuate shape of the mating surfaces of the facet joint FJ_1 , FJ_2 , as would be apparent to one having ordinary skill in the art.

[0041] The inner surfaces 24, 34 of the first and second component 20, 30 may also include a cannulated opening 42 for receipt of a guide wire 200 (Fig. 8), as will be described in greater detail below.

[0042] Referring to Fig. 2C, the facet interference screw 10 of the first preferred embodiment may also include a temporary spacer 40 located between the inner surfaces 24, 34 of the first and second components 20, 30, at least in an insertion configuration. Preferably, the temporary spacer 40 includes a cannulated opening 42 for receipt of a guide wire 200 (Fig. 8), as will be described in greater detail below. In use, the temporary spacer 40 is inserted between the inner surfaces 24, 34 of the first and second components 20, 30 in the insertion configuration. The facet interference screw 10 with the temporary spacer 40 mounted therein is inserted between the inferior facet F_i formed on the superior vertebra V and the superior facet F_s formed on the inferior vertebra V via rotation of the facet interference screw 10. Once positioned in the mounted position, the spacer 40 is preferably removed and the inner surfaces 24, 34 move into facing engagement or contact to facilitate motion therebetween. The guide wire 200 may include a larger diameter portion 202 at a distal end that engages and removes the temporary spacer 40 upon removal of the guide wire 200 from the facet joint FJ_1 , FJ_2 . In this manner, the spacer 40 facilitates insertion of the facet interference screw 10 of the first preferred embodiment between the inferior facet F_i and the superior facet F_s with the assistance of the guide wire 200. In use, the spacer 40 prevents surface contact between

the inner surfaces 24, 34 of the first and second components 20, 30. In the mounted position, removal of the spacer 40 preferably enables the curved inner surfaces 24, 34 to articulate along the curved or arcuate path. In addition, the facet interference screw 10 of the first preferred embodiment is positioned in the mounted position such that the articulation plane R_P of the facet interference screw 10 is generally parallel to the first or second facet joint plane FJ_{P1} , FJ_{P2} , respectively to facilitate restoration of a near-normal articulation or movement of the respective facet joint FJ_1 , FJ_2 .

[0043] Referring to Figs. 3A-3D, a second preferred embodiment of the facet interference screw 10' is similar to the first preferred embodiment of the facet interference screw 10 except that the second preferred embodiment of the facet interference screw 10' includes a damping component 60a', 60b', 60c' located between the inner surfaces (not shown in the second preferred embodiment) of the first and second components 20', 30' to facilitate damping and/or movement of the first and second components 20', 30' with respect to one another. The facet interference screw 10' of the second preferred embodiment is shown with like reference numerals to indicate like elements and a prime symbol (') to distinguish the elements of the facet interference screw 10' of the second preferred embodiment. The preferred damping component 60a', 60b', 60c' preferably facilitates compression of the first and second components 20', 30' with respect to one another. In addition, the preferred damping component 60a', 60b', 60c' enables lateral and longitudinal movement between the first and second components 20', 30'. The damping component 60a', 60b', 60c' is preferably constructed of a relatively elastic material that permits movement in six degrees of freedom between the first and second components 20', 30'. For example, the damping component 60a', 60b', 60c' may

be constructed of a polymeric material that is strong enough to withstand the typical loads encountered by the facet interference screw 10' when mounted in the facet joint FJ and is able to withstand the environment encountered during permanent implantation in the facet joint FJ.

[0044] The damping component 60a', 60b', 60c' of the second preferred embodiment may be pre-assembled and/or connected to the first and/or second components 20', 30' by any mechanism now or hereafter known in the art including but not limited to an adhesive, a mechanical connection, *etc.* Alternatively, the damping component 60a', 60b', 60c' may be inserted between the inner surfaces 24', 34' after the first and second components 20', 30' are inserted into the facet joint FJ in a mounted position, either with or without the temporary spacer (not shown in Figs. 3A-3D). That is, for example, the facet interference screw 10' of the second preferred embodiment may be inserted into the facet joint FJ and the first and second components 20', 30' may then be separated to receive the damping component 60a', 60b', 60c' therebetween.

[0045] In the second preferred embodiment, the damping component 60a', 60b', 60c' may have several configurations including a first preferred damping component 60a' that includes the cannulated opening 42' therein, a second preferred damping component 60b' that is generally solid and continuous and a third preferred damping component 60c' that includes a guiding and locking mechanism 70'. The first preferred damping component 60a' includes the cannulated opening 42' to accommodate the guide wire 200 therein during implantation of the facet interference screw 10'. The first preferred damping component 60a' is preferably, permanently bonded to the first and second components 20', 30' prior to implantation in the facet joint FJ. The second preferred damping

component 60b' includes a generally solid, integral configuration without the cannulated opening 42'. The second preferred damping component 60b' may be permanently bonded or joined to the first and second components 20', 30' or may be inserted between the first and second components 20', 30' following initial implantation and removal of the spacer 40' (not shown in Figs. 3A-3D). A third preferred damping component 60c' preferably includes a guiding and locking mechanism 70' to facilitate insertion of the damping component 60c' between the first and second components 20', 30'. The guiding and locking mechanism 70' may be comprised of any mechanism now or hereafter known including, but not limited to, a tongue and groove system. For example, the inner surface 24', 34' of at least one of the first and second components 20', 30' may include a groove (not shown) for mating with the T-shaped locking mechanism 70' extending from the damping component 60'. In addition, the surfaces of the first and second preferred damping components 60a', 60b' that mate with the first and second components 20', 30' are not limited to being generally flat and continuous, as is shown in the Figs., but may include engagement features or may be generally rough in order to facilitate engagement and mating with the inner surfaces of the first and second components 20', 30'. For example, the first, second and/or third damping components 60a', 60b', 60c' may be injection molded to the first and second components 20', 30', which have roughened, grooved, spiked or otherwise uneven inner surfaces to assist in retaining the damping components 60a', 60b', 60c' to the first and second components 20', 30'.

[0046] Referring to Figs. 4A-6B, a third preferred embodiment of the facet interference screw 10'' includes a two-piece damping component 60'', although three or more pieces are also contemplated. The facet interference screw 10'' of the third

preferred embodiment is shown with like reference numerals to indicate like elements and a double prime symbol (") to distinguish the elements of the facet interference screw 10" of the third preferred embodiment. The two-piece damping component 60" preferably includes an upper damping component 62" mounted to the inner surface 24" of the first component 20" and a lower damping component 64" mounted to the inner surface 34" of the second component 30". The upper and lower damping components 62", 64" preferably each include curved contacting surfaces 62a", 64a" so that the upper damping component 62" is moveable with respect to the lower damping component 64" and the first component 20" is moveable with respect to the second component 30". More preferably, the curved contacting surfaces 62a", 64a" formed on the upper and lower damping components 62", 64" preferably have corresponding spherical surfaces in both the longitudinal direction (*e.g.*, parallel to the longitudinal axis 13") and in the lateral direction (*e.g.*, perpendicular to the longitudinal axis 13"). In this manner, the spherical curved contacting surfaces 62a", 64a" facilitate flexion/extension articulation and lateral articulation, as illustrated in Figs. 5A-6B. The inner surfaces 24", 34" may also facilitate the cannulated opening 42" for receipt of the guide wire 200 to guide implantation of the facet interference screw 10" of the third preferred embodiment. However, the facet interference screw 10" of the third preferred embodiment is not limited to inclusion of the cannulated opening 42" and may be constructed without the cannulated opening 42" such that the upper and lower damping components 62a", 64a" are in contact along substantially their entire spherical curved contacting surfaces 62a", 64a" in the assembled configuration.

[0047] The upper and lower damping components 62", 64" are preferably constructed of a polymeric material that provides some elasticity, but also is rigid enough to resist significant wear at the curved contacting surfaces 62a", 64a" during use in the mounted position. For example, the upper and lower damping components 62", 64" may be constructed of a polyetheretherketone (PEEK) material, but is not so limited and may be constructed of nearly any material that provides damping and wear capability and is able to withstand the normal operating conditions and environment of the mounted position. In addition, the first and second components 20", 30" are preferably constructed of a metallic material, such as titanium or steel, but is not so limited and may be constructed of nearly any biocompatible material that is able to take on the general shape of the first and second components 20", 30" and withstand the normal operating conditions of the facet interference screw 10".

[0048] Referring to Figs. 7A and 7B, the facet interference screws 10, 10', 10'' of the first, second and third preferred embodiments may also include an anti-rotational mechanism or feature 100a, 100b to inhibit the facet interference screws 10, 10', 10'' from backing out of the mounted position. For example, a first anti-rotational mechanism 100a may be in the form of a spacer 100a that is inserted between the first and second components 20, 30 so that the profile of the facet interference screws 10, 10', 10'' is no longer circular in the mounted position and thus less likely to back-out or otherwise rotate in the mounted position. The spacer 100a is preferably constructed of a damping-type material to permit limited movement between the first and second components 20, 30. More preferably, as shown in Fig. 7B, a second preferred anti-rotational spacer 100b may have a width wider than the diameter of the facet interference screw 10, 10', 10'' in at

least one portion of its length, thereby further inhibiting back out. The anti-rotational mechanism 100a, 100b may be separate and distinct from the preferred damping components 60a', 60b', 60c', 60'' or may be integrally formed therewith. Alternatively, the facet interference screw 10, 10', 10'' may incorporate an anti-rotation mechanism having a U-shape, as is disclosed in U.S. Published Patent Application No. 2006/0064099, titled Articular Facet Interference Screw and filed November 13, 2002, which is incorporated herein by reference in its entirety.

[0049] Referring to Figs. 2A, 3A, 4A, 5A, 6A and 7A, the facet interference screws 10, 10', 10'' of the preferred embodiments preferably have a screw diameter D and a screw length L. The screw length L is preferably between five (5) and twenty-five (25) millimeters and the screw diameter D is preferably between four (4) and eleven (11) millimeters. The facet interference screws 10, 10', 10'' are not limited to these dimensions, but preferably fall within these ranges to permit the minimally invasive insertion of the facet interference screws 10, 10', 10'' into the facet joints FJ, to limit the extension of the tip 16a through the facet joints FJ, to permit the facet interference screws 10, 10', 10'' to travel through a cannula (not shown) during a minimally invasive procedure and for other related considerations. In addition, the facet interference screws 10, 10', 10'' of the preferred embodiments preferably include the head portion 14, 14', 14'' to facilitate engagement by an insertion and/or removal tool and to inhibit the distance that the facet interference screws 10, 10', 10'' are inserted into the facet joints FJ.

[0050] Referring to Figs. 6A-7B, the facet interference screws 10, 10', 10'' of the preferred embodiments may include an articulation indicator 50, 50'' on the head 14, 14''

that aligns with the articulation plane R_P of the facet interference screw 10, 10', 10". The articulation indicator 50, 50" provides a visual indicator to the surgeon to verify that the articulation plane R_P of the facet interference screw 10, 10', 10" is aligned with the facet joint planes FJ_{P1} , FJ_{P2} in the mounted position. Misalignment or misorientation of the articulation plane R_P typically limits the facet interference screw 10, 10', 10" from operating in its intended manner and may result in a fusion of the facet joints FJ.

Alternatively, the surgeon may elect to insert the facet interference screw 10, 10', 10" such that the articulation plane R_P is misaligned with the facet joint planes FJ_{P1} , FJ_{P2} such that fusion is intentionally promoted in the facet joints FJ. Further, the articulation indicator 50, 50" may be curved or otherwise provide an indication that the inner surfaces 24, 34 are curved to create a curved articulation path such that the surgeon is able to arrange the articulation plane R_P with the naturally curved articulation of the facet joints FJ.

[0051] In use, the facet interference screws 10, 10', 10" of the preferred embodiments are self-tapping and/or self-drilling. The first and second components 20, 30 are preferably preassembled either alone or in connection with a preferred temporary spacer 40 and/or damping component 60a', 60b', 60c', 60" by, for example, a rigid connection in the screw head 14 so that, in use, the facet interference screw 10, 10', 10" can be inserted by, rotating the facet interference screw 10, 10', 10" into the facet joints FJ via a screw driver 225, as shown in Fig. 8. Preferably, the articulation plane R_P of the facet interference screws 10, 10', 10" are aligned with the facet joint planes FJ_{P1} , FJ_{P2} in the mounted position to permit articulation of the facet joints FJ with the facet interference screws 10, 10', 10" mounted therein. Alternatively, the articulation plane R_P may be

intentionally misaligned with the facet joint planes FJ_{P1} , FJ_{P2} to promote fusion or limit movement in the facet joints FJ.

[0052] Referring to Figs. 9A-9D, a preferred screw driver 225 for inserting, implanting and/or driving the facet interference screws 10, 10', 10'' into the facet joints FJ includes a mechanism to secure the first and second components 20, 30 and any additional component parts together and to maintain adequate torque during insertion. The preferred screw driver 225 includes a shaft 227 and a sleeve 230. The shaft 227 preferably includes a tip 228 for simultaneously engaging the first and second components 20, 30 of the facet interference screw 10, 10', 10''. The tip 228 preferably includes a plurality of projections 229 for engaging a plurality of recesses 44 formed in the head portion 14 of the facet interference screw 10, 10', 10''. The sleeve 230 is preferably moveably disposed over the shaft 227 from an extended position (as shown in phantom lines in Figs. 9A and 9B) wherein the sleeve 230 encapsulates the facet interference screw 10, 10', 10'' coupled to the distal end of the screwdriver 225, to a retracted position (as shown in Fig. 9C) wherein the facet interference screw 10, 10', 10'' coupled to the distal end of the screwdriver 225 is exposed. The sleeve 230 is preferably biased via, for example, a spring 235 to the extended position.

[0053] The screwdriver 225 also preferably includes an indicator 225a at a proximal end of the handle of the screwdriver 225 to provide an indication of the articulation plane R_P of the facet interference screw 10, 10', 10''. The facet interference screw 10, 10', 10'' is preferably mountable onto the screwdriver 225 in a single orientation such that the indicator 225a aligns with the articulation plane R_P of the screw facet interference screw 10, 10', 10''. Accordingly, the surgeon is able to verify the orientation of the articulation

plane R_P in the mounted position to align with the facet joint planes FJ_{P1} , FJ_{P2} to promote articulation or in misalignment to promote fusion, as is apparent to one having ordinary skill in the art based upon a review of the present disclosure.

[0054] In use, the user preferably moves the sleeve 230 to the retracted position so that the facet interference screw 10, 10', 10'' may be coupled to the distal end of the screwdriver 225. The sleeve 230 moves via the spring bias into the extended position so that the facet interference screw 10, 10', 10'' is encapsulated by the sleeve 230. In the extended position, the sleeve 230 assists in maintaining the first and second components 20, 30 of the facet interference screw 10, 10', 10'' together so that the multiple components of the facet interference screw 10, 10', 10'' can be rotated as a single unit into the facet joints FJ. During insertion, contact between the distal end of the sleeve 230 and the patient's bone moves the sleeve 230 from the extended position to the retracted position to expose the facet interference screw 10, 10', 10''. The facet interference screw 10, 10', 10'' is driven into the facet joint FJ until the head 14 contacts the bone of the facet joint FJ and the surgeon preferably aligns the indicator 225a with the facet joint planes FJ_{P1} , FJ_{P2} .

[0055] Primary fixation of the facet interference screw 10, 10', 10'' into the facet joints FJ may be achieved by the external threads on the shaft portion 16 of the facet interference screw 10, 10', 10'' engaging the superior and inferior facets F_S , F_i . Secondary fixation may be achieved by osteo-integration. For example, the facet interference screws 10, 10', 10'', and in particular the external threads formed on the shaft portion 16 of the facet interference screws 10, 10', 10'', may be roughened and/or coated for osteo-conduction. The facet interference screws 10, 10', 10'' may be coated with any

bioactive coating now or hereafter known including, but not limited to, Ti-Plasma spray, anodic surface enhancement such as, for example, APC, HA or any Ca-P enhancement, *etc.*

[0056] The preferred facet interference screws 10, 10', 10'' and the anti-rotational mechanisms 100, 100' may be manufactured from any biocompatible material known in the art including but not limited to stainless steel, titanium, titanium alloy, a polymer such as, for example, PPEK, PEKK, PEK, PEKK-EK with or without an optional carbon fiber reinforcement, *etc.*, a ultra-high-molecular-weight polyethylene (UHMWPE), cobalt-chromium-molybdenum (CCM), *etc.*

[0057] The damping components 60a', 60b', 60c', 60'' may be manufactured from any biocompatible material known in the art including but not limited an elastomeric-thermoplastic polymer (PCU or polymerized Silicone), a member of PUR or Silicone family, a copolymer, *etc.* Preferably the damping components 60a', 60b', 60c', 60'' has a profile (*e.g.*, size and shape) that matches or substantially matches the profile (*e.g.*, size and shape) of the first and second components 20, 30. The damping components 60a', 60b', 60c', 60'' may be coated, either partially or completely, to reduce the amount of wear. For example, the damping components 60a', 60b', 60c', 60'' may be coated with any metal carbide or nitride, member of the DLC family, Al₂O₃, ZrO₂, TiC, TiN, (A)DLC, CrN, CrC, *etc.*

SURGICAL TECHNIQUE

[0058] The facet interference screws 10, 10', 10'' of the first, second and third preferred embodiments may be inserted by any surgical technique known in the art. The facet interference screws 10, 10', 10'' may be inserted percutaneously, similar to the

insertion of the facet interference screw disclosed in U.S. Patent Application No. 11/126,976, entitled Articular Facet Interference Screw, which was filed on May 10, 2005 and is assigned to the Synthes (U.S.A.), the entire contents of which is incorporated herein by reference.

[0059] Referring to Fig. 8, in use, the facet interference screws 10, 10', 10'' of the first, second and third preferred embodiments are inserted into the facet joint FJ via a minimally invasive procedure. It is envisioned that the facet interference screws 10, 10', 10'' may also be inserted through an open surgery. In one exemplary method of inserting the facet interference screws 10, 10', 10'', the guide wire 200 is introduced percutaneously into each of the facet joints FJ between the adjacent superior and inferior vertebra V. The introduction of the guide wires 200 may be guided into the facet joints FJ by any means including, but not limited to C-arm imaging, CT-scan, a mini-open approach to the facet joints FJ, *etc.* After verifying the symmetrical position of the guide wires 200, an optional tissue protection sleeve, cannula, retractor and/or trocar (not shown) may be guided to the facet joint FJ to open a path to the facet joint FJ. The facet interference screws 10, 10', 10'' are introduced into the facet joints FJ, preferably via the guide wires 200 and through the protection sleeve, cannula, retractor or trocar. Thereafter, the orientation of the facet interference screw 10, 10', 10'' is preferably verified, and the guide wires 200, instrumentation and temporary spacer 40 (if required) are removed. If necessary, the damping component 60a', 60b', 60c', 60'' and the anti-rotational mechanism 100a, 100b, if desired, may be inserted between the inner surfaces 24, 34 of the first and second components 20, 30. The orientation of the articulation

plane R_P is verified by one or both of the indicators 50, 225a, specifically with respect to the facet joint planes FJ_{P1} , FJ_{P2} .

[0060] It will be appreciated by those skilled in the art that changes could be made to the embodiments described above without departing from the broad inventive concept thereof. It is understood, therefore, that this invention is not limited to the particular embodiments disclosed, but is intended to cover modifications within the spirit and scope of the present invention as defined by the appended claims.

CLAIMS

1. A facet interference screw for insertion into a facet joint between an inferior facet of a superior vertebra and a superior facet of an inferior vertebra, the facet interference screw comprising:

a first component including a first outer semicircular, threaded surface and a first inner surface; and

a second component including a second outer semicircular, threaded surface and a second inner surface, the first and second components defining a head portion, a tip, a longitudinal axis extending between the head and the tip and an externally threaded shaft portion in an assembled configuration, the first and second inner surfaces extending from the head portion to the tip in the assembled configuration, the first and second surfaces being substantially in contact in the assembled configuration.

2. The screw of claim 1, wherein the first and second inner surfaces are generally parallel to an articulation plane of the facet interference screw.

3. The screw of claim 1, wherein the inner surfaces of the first and second components of the facet interference screw are curved.

4. The screw of claim 1, further comprising:

a damping component located between the inner surfaces of the first and second components.

5. The screw of claim 4, wherein the inner surface of at least one of the first and second components includes a guiding mechanism.

6. The screw of claim 4, wherein the damping component includes an upper damping component having an outer surface contacting the inner surface of the first component and an inner surface and a lower damping component having an outer surface for contacting the inner surface of the second component and an inner surface, the inner surfaces of the upper and lower damping components being curved and in contact with each other such that the upper damping component is articulable with respect to the lower damping component.

7. The screw of claim 6, wherein the curved contacting surfaces are spherical surfaces.

8. The screw of claim 4, wherein the damping component has a profile that matches the profile of the first and second components.

9. The screw of claim 1 further comprising:

an indicator on the head that is aligned with an articulation plane of the facet interference screw.

10. A facet interference screw for insertion into a facet joint between an inferior facet formed on a superior vertebra and a superior facet formed on an inferior vertebra, the facet interference screw comprising:

a first component having an externally threaded surface and a first inner surface;

a second component having an externally threaded surface and a second inner surface, wherein the first and second components define a head, a tip and a shaft portion in an assembled configuration; and

a damping component located between the first and second components and extending generally along the longitudinal axis, the damping component being in contact with the first and second inner surfaces.

11. The facet interference screw of claim 10 wherein the damping component is constructed of an elastomeric-thermoplastic polymer.

12. The facet interference screw of claim 10 wherein the damping component is adhesively bonded to the first and second inner surfaces.

13. The facet interference screw of claim 10 further comprising:

an indicator positioned on the head to identify an orientation of an articulation plane of the facet interference screw, the articulation plane extending through the damping component.

14. The facet interference screw of claim 10 wherein the damping component includes a cannulated opening extending from the head to the tip, generally co-axially with the longitudinal axis.

15. A method for inserting a first facet interference screw and a second facet interference screw, each including a first component having an externally threaded surface and a first inner surface and a second component having an externally threaded surface and a second inner surface, the method comprising the steps of:

a) inserting a temporary spacer between the first and second inner surfaces of the first and second components;

b) inserting a guide wire at least partially into facet joints between adjacent superior and inferior vertebra;

c) guiding the first and second interference screws down the guide wires such that tips of the first and second interference screws are positioned adjacent the facet joints;

d) driving the first and second facet interference screws simultaneously into each of the facets joints until the heads contact the bone of the facet joints; and

d) removing the guide wire, which causes the guide wire to contact and remove the temporary spacer from between the first and second inner surfaces of the first and second components.

16. The method of claim 15, comprising the further step of:

e) inserting a damping component between the first and second inner surfaces following step (d).

17. The method of claim 15 comprising the further step of:

e) aligning an indicator on the heads of the first and second interference screws with facet joint planes of the facet joints.

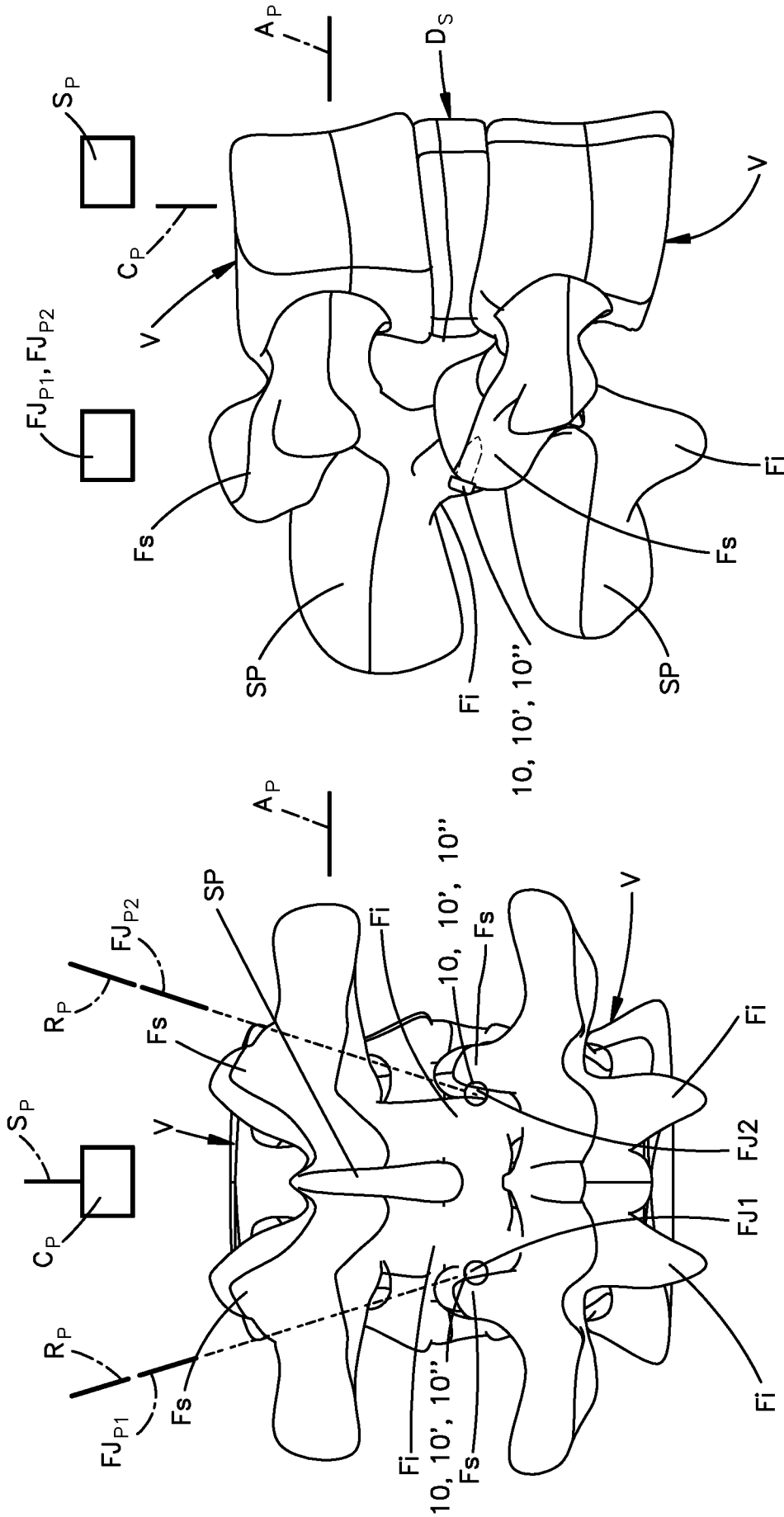

Fig.1B

Fig.1A

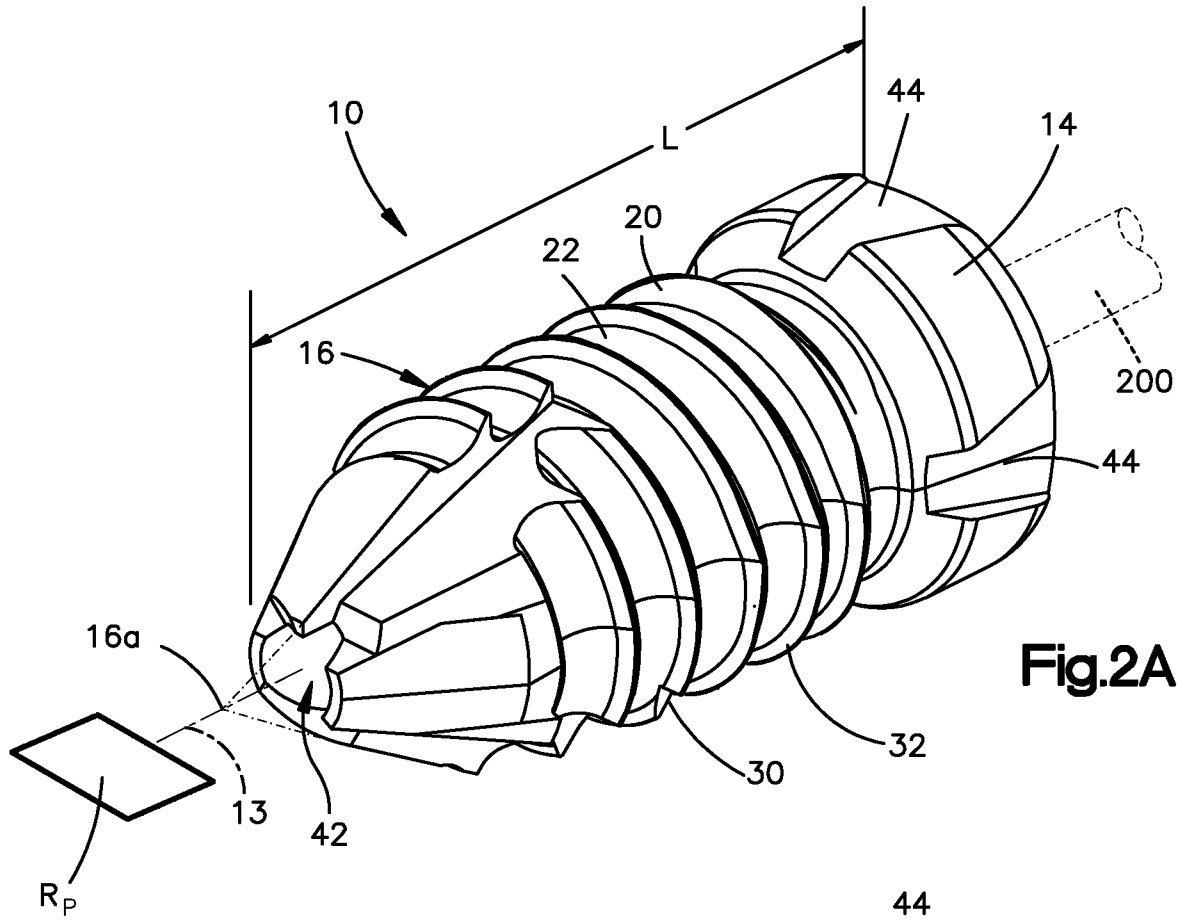

Fig.2A

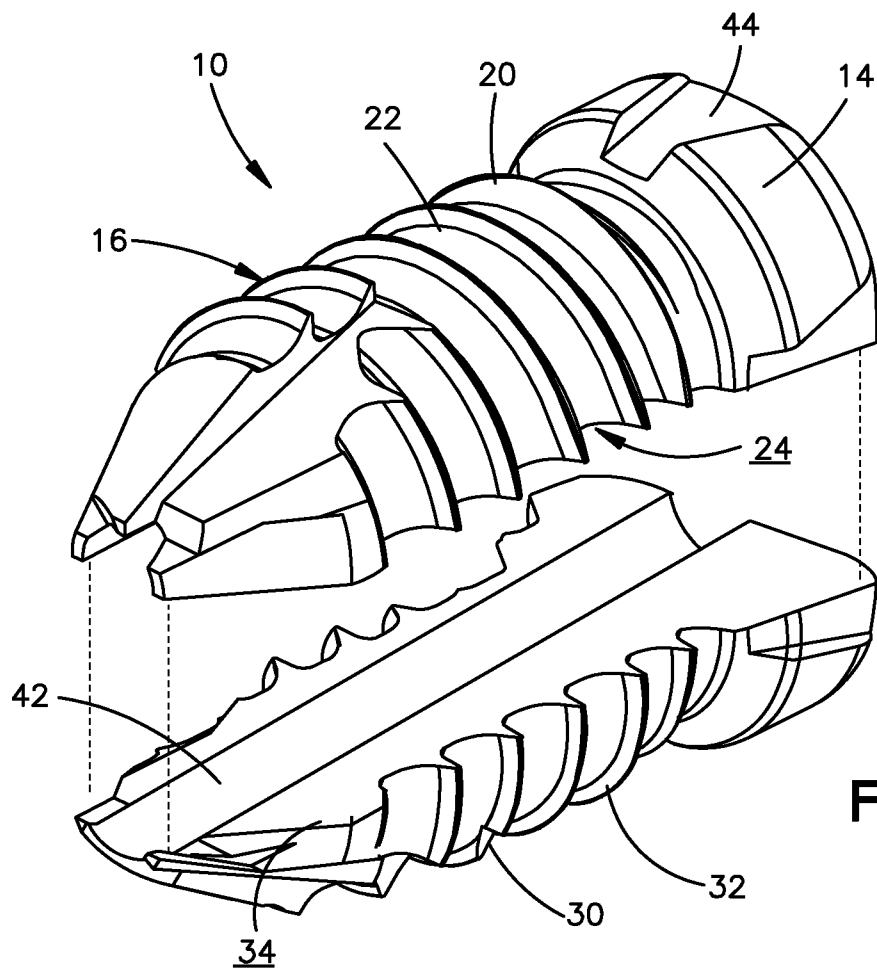

Fig.2B

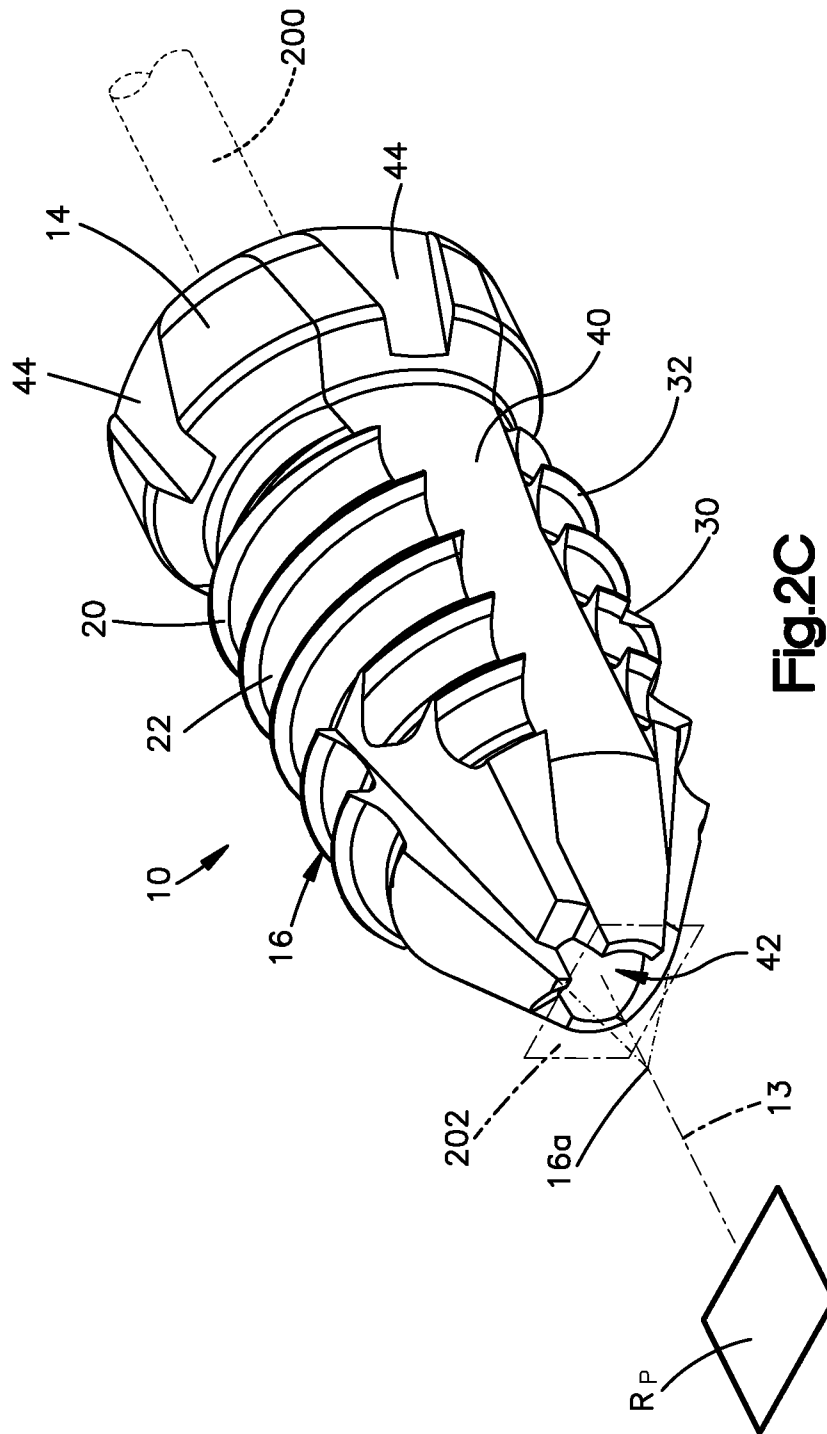
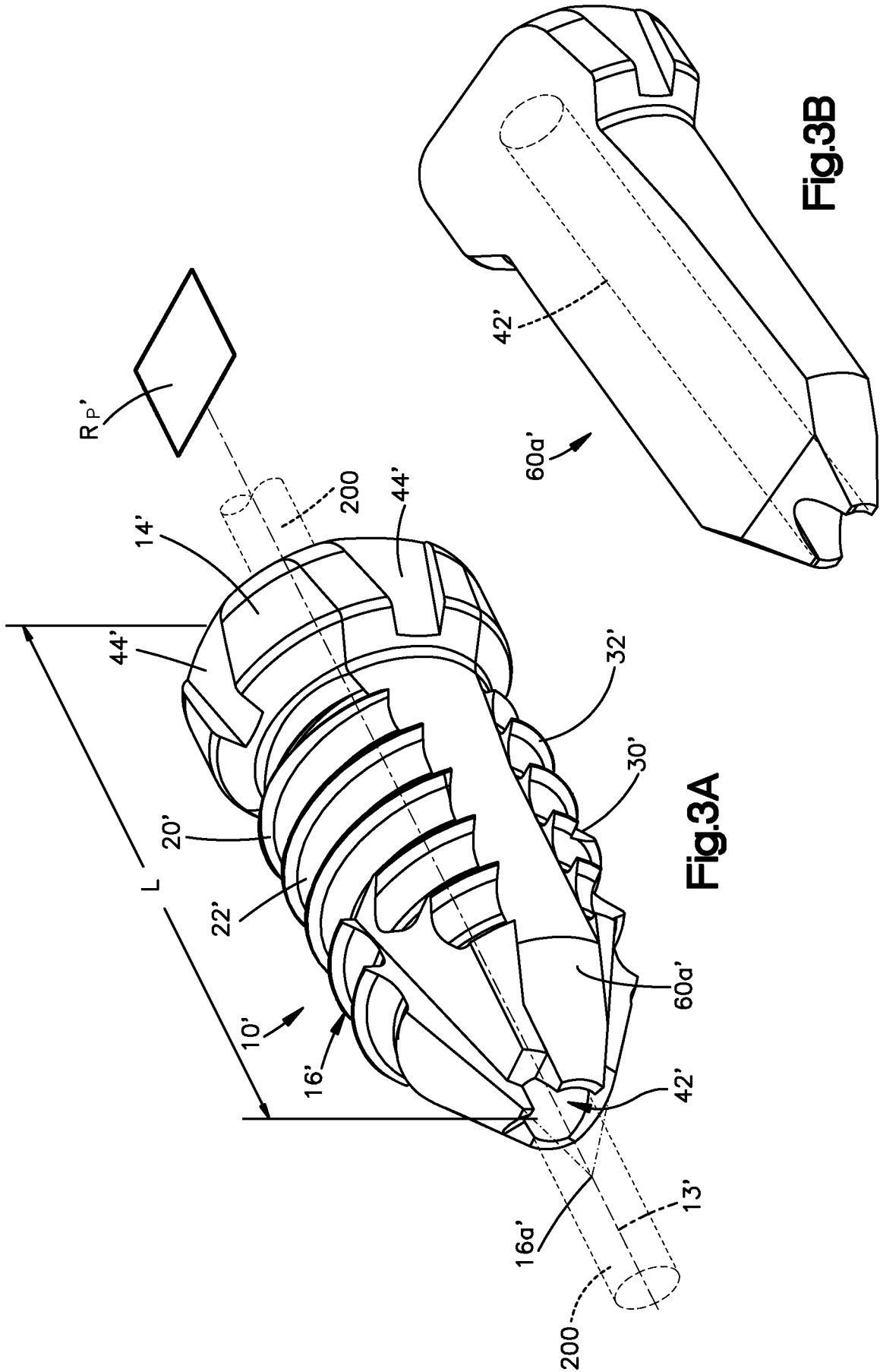

Fig.2C



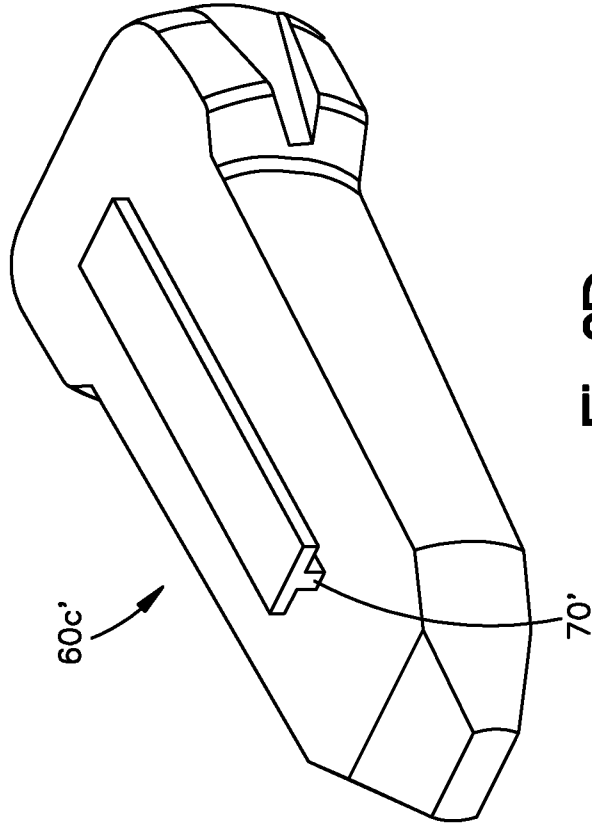

Fig.3D

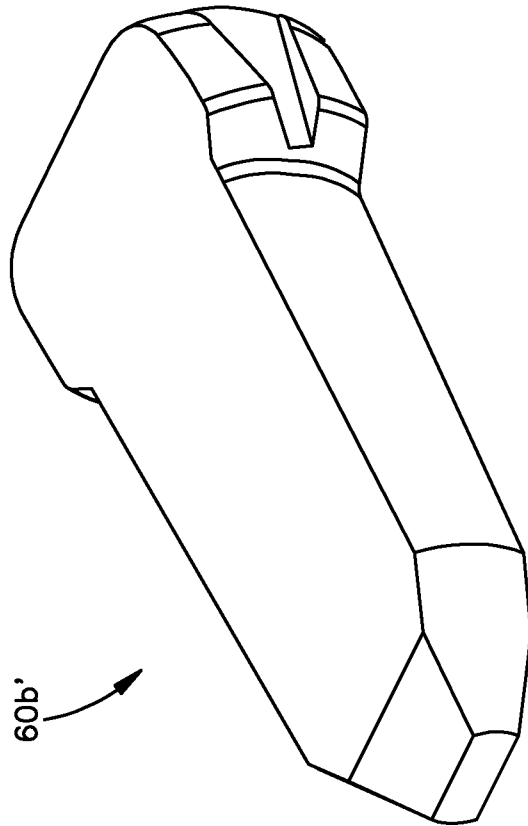

Fig.3C

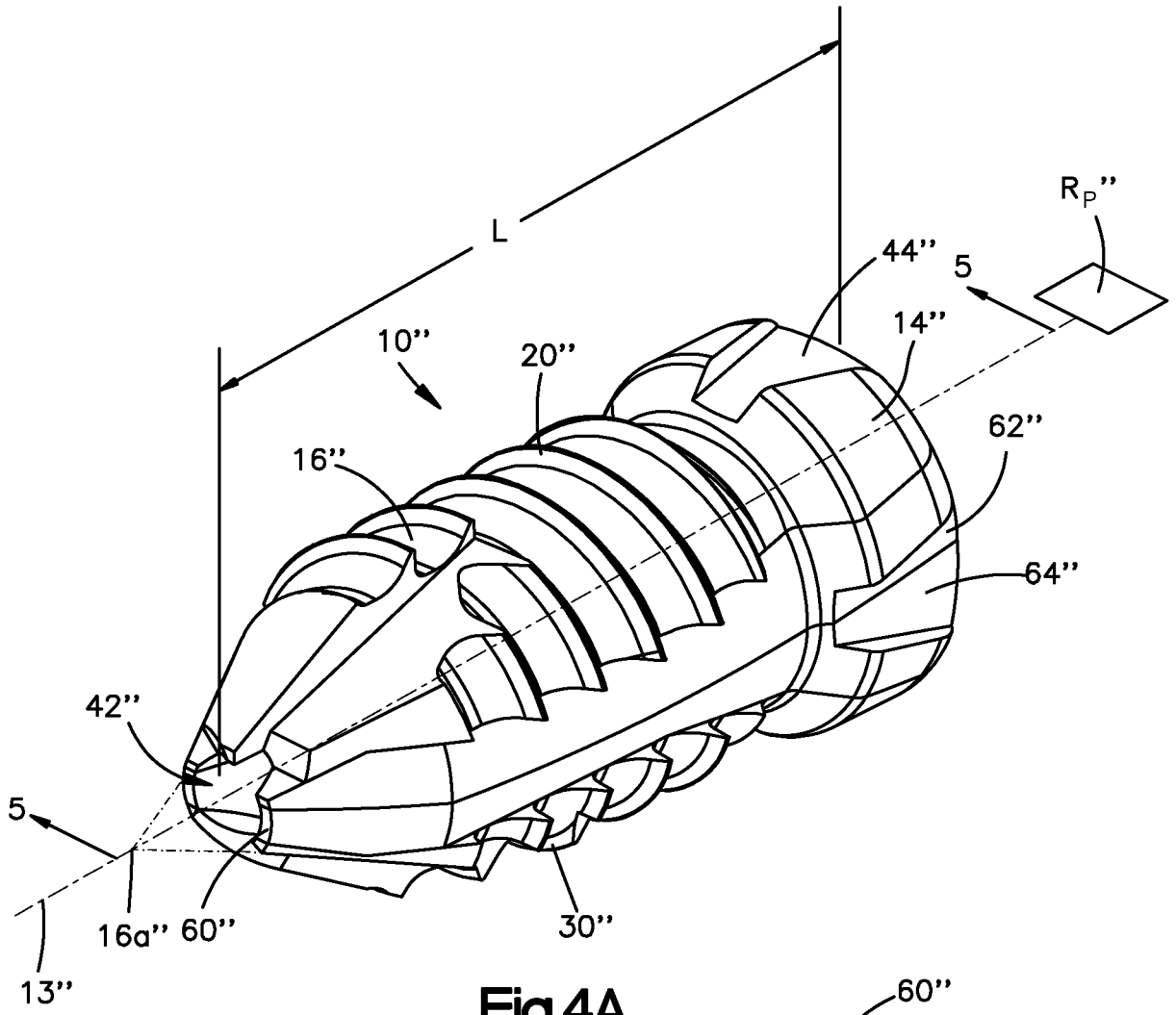

Fig.4A

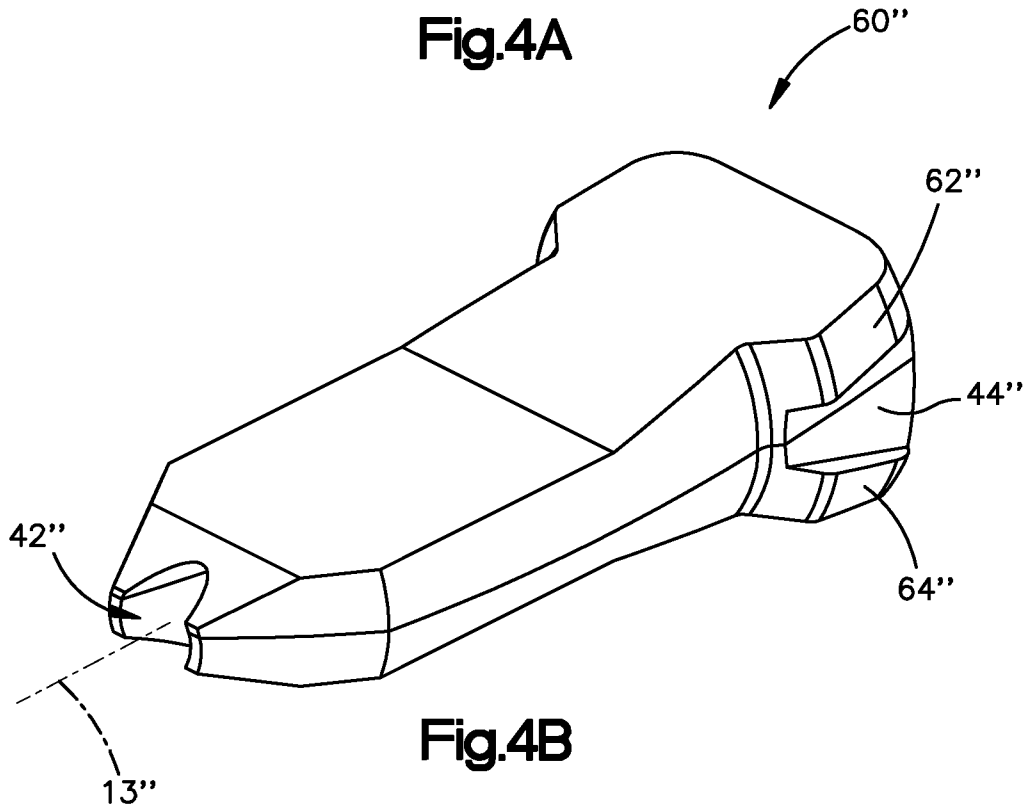

Fig.4B

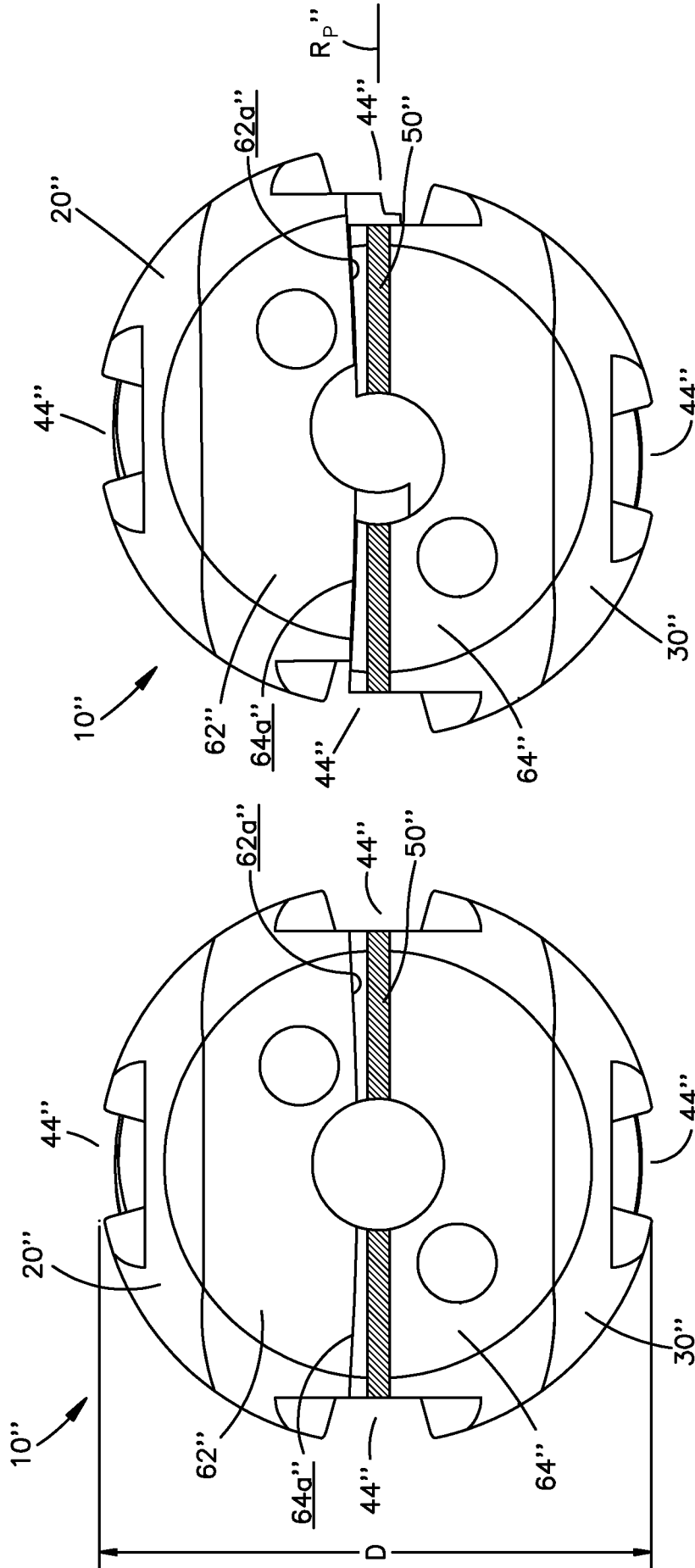

Fig.6B

Fig.6A

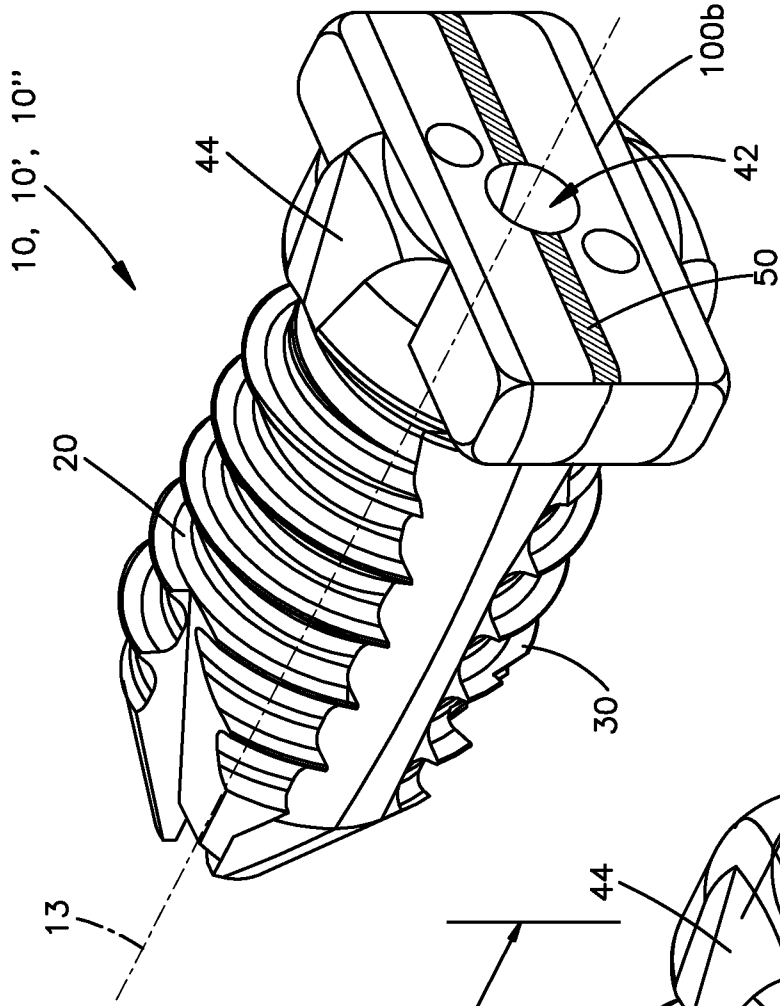

Fig.7B

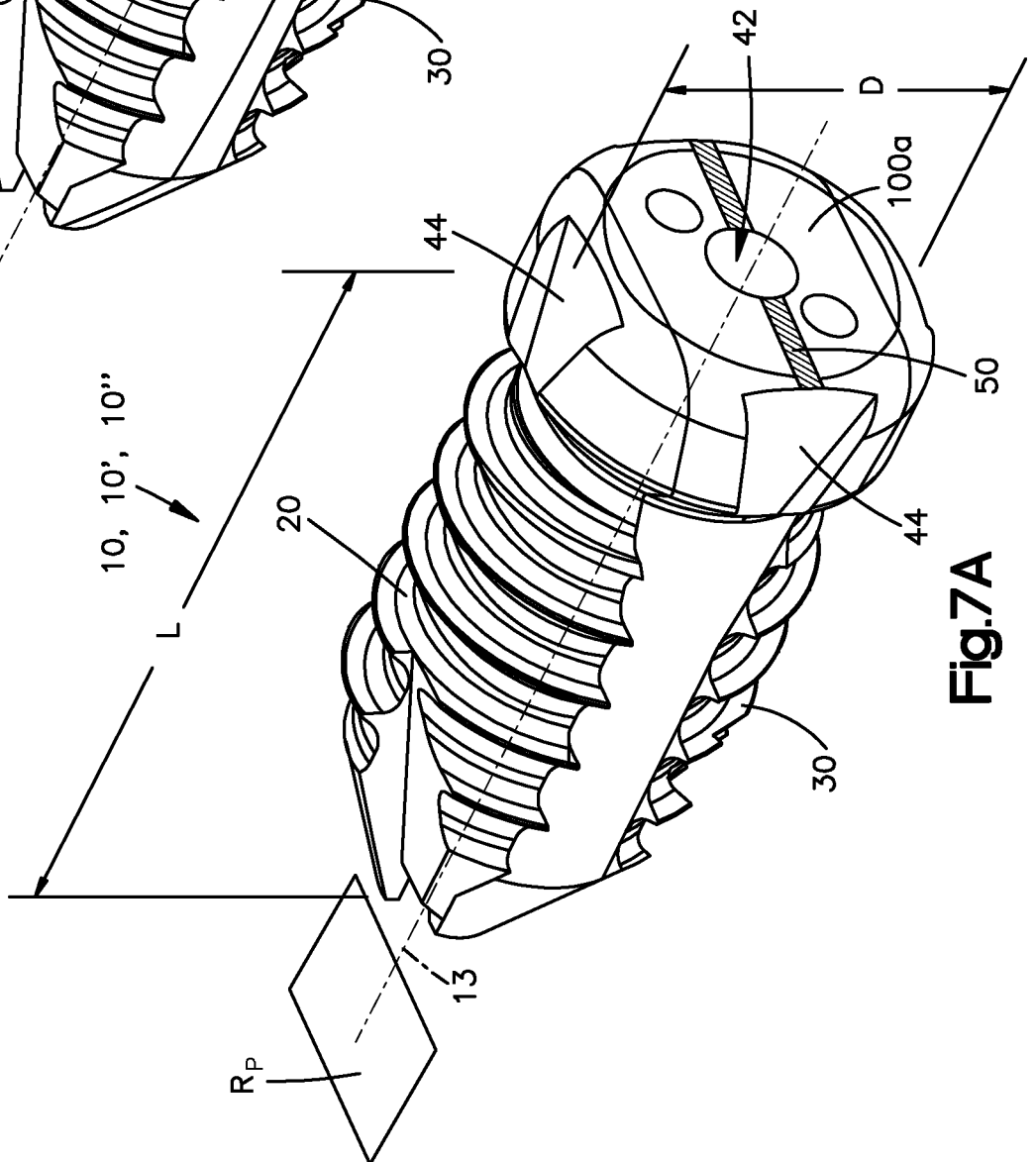
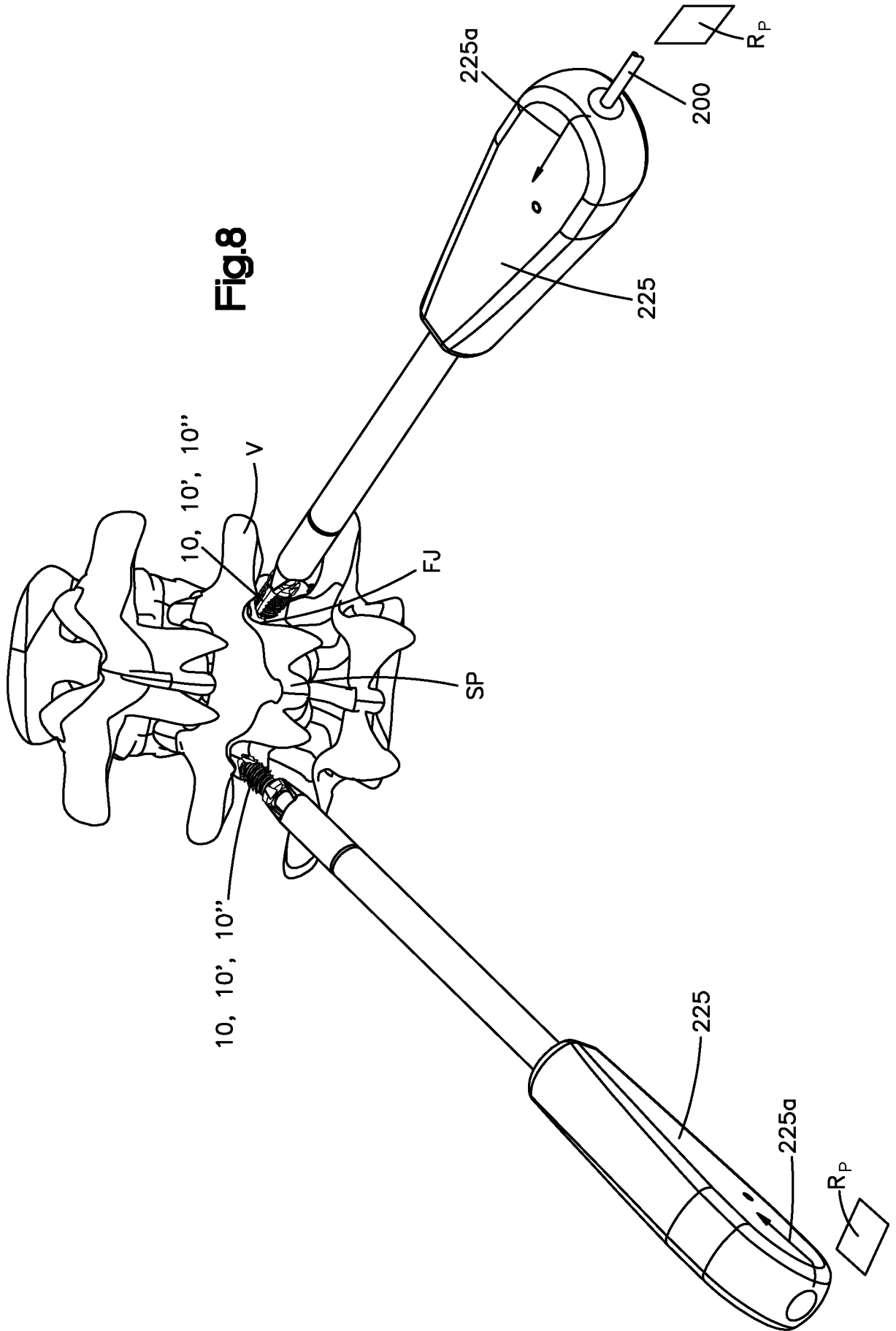

Fig.7A

Fig.8



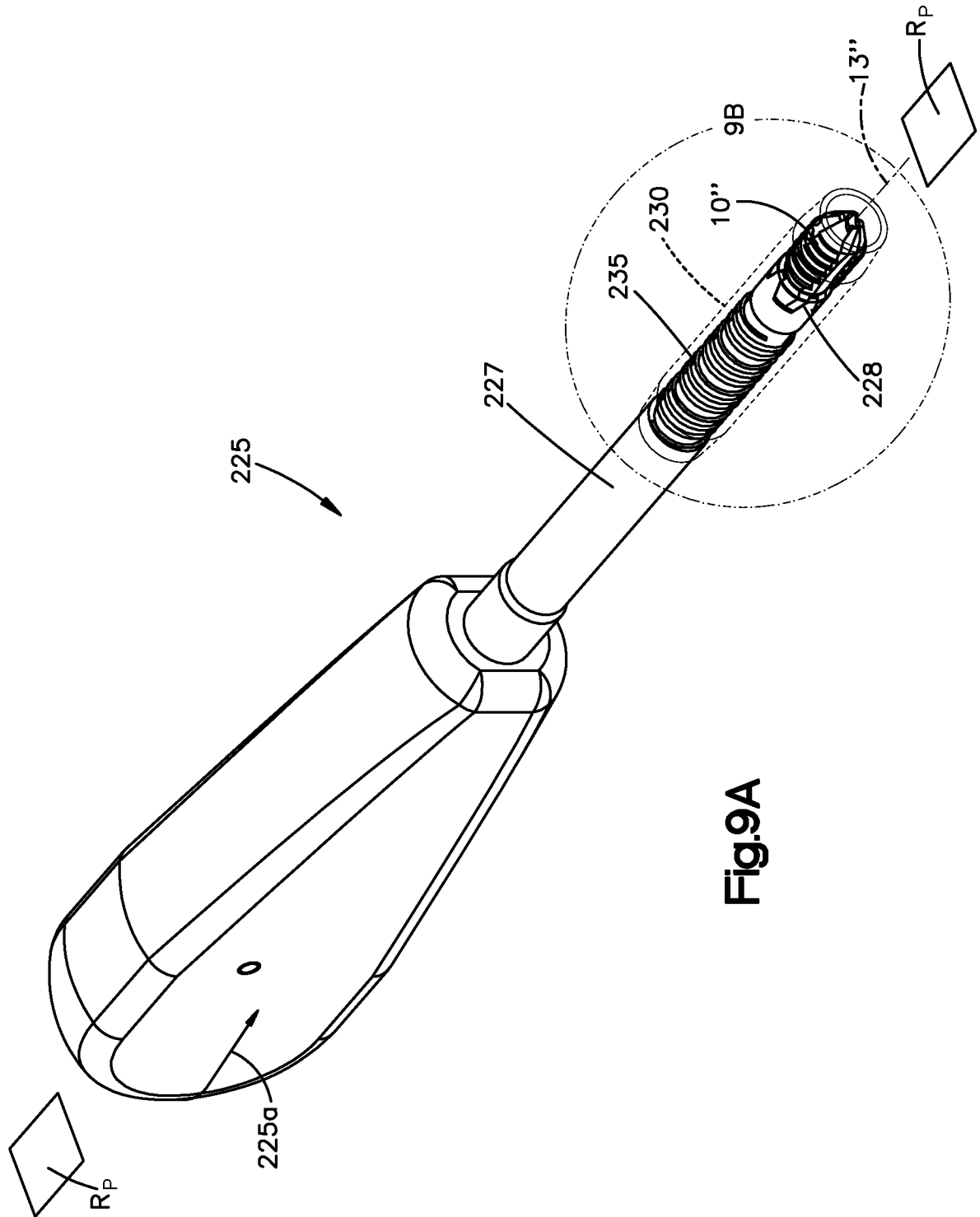

Fig.9A

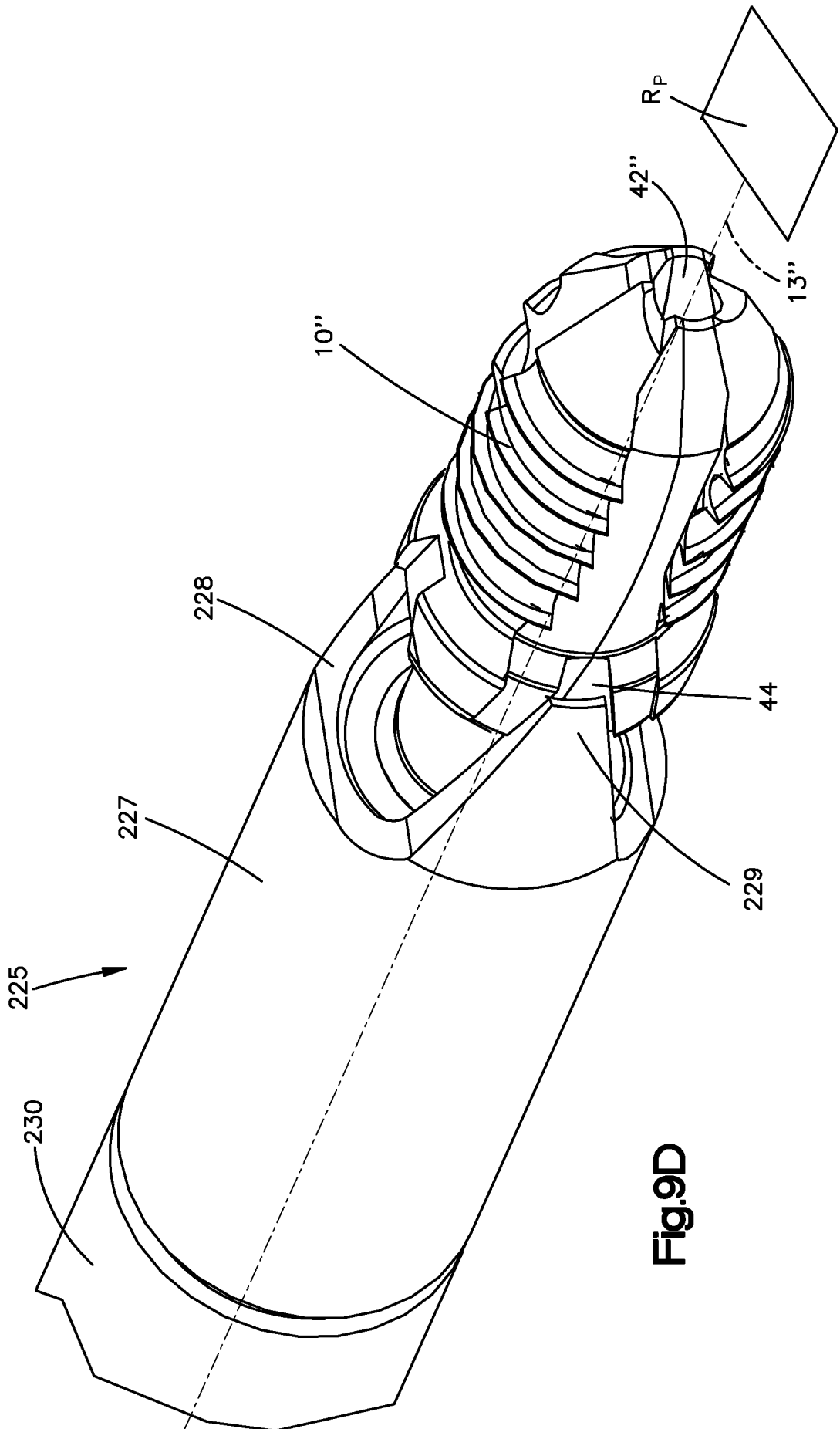

Fig.9D

INTERNATIONAL SEARCH REPORT

International application No
PCT/US2009/036175

A. CLASSIFICATION OF SUBJECT MATTER		
INV.	A61B17/86	A61B17/88 A61B17/70 A61L27/28 A61F2/44
According to International Patent Classification (IPC) or to both national classification and IPC		
B. FIELDS SEARCHED		
Minimum documentation searched (classification system followed by classification symbols) A61B A61L A61F		
Documentation searched other than minimum documentation to the extent that such documents are included in the fields searched		
Electronic data base consulted during the international search (name of data base and, where practical, search terms used) EPO-Internal		
C. DOCUMENTS CONSIDERED TO BE RELEVANT		
Category*	Citation of document, with indication, where appropriate, of the relevant passages	Relevant to claim No.
X	US 2004/049280 A1 (CAUTHEN JOSEPH C [US]) 11 March 2004 (2004-03-11) page 3, paragraph 38 - page 6, paragraph 59 figures 1A,1B,3,5,7-9,10a	1-5,8,9
A		10,11
X	US 5 928 284 A (MEHDIZADEH HAMID M [US]) 27 July 1999 (1999-07-27) column 2, line 31 - column 3, line 23 figures 1,2	10-14
A		1,2,4,9
X	US 6 419 706 B1 (GRAF HENRY [FR]) 16 July 2002 (2002-07-16) column 2, line 46 - column 8, line 56 figures 1,2,18	10-12
A		1,3-5,8
	----- -/--	
<input checked="" type="checkbox"/> Further documents are listed in the continuation of Box C. <input checked="" type="checkbox"/> See patent family annex.		
* Special categories of cited documents : *A* document defining the general state of the art which is not considered to be of particular relevance *E* earlier document but published on or after the international filing date *L* document which may throw doubts on priority claim(s) or which is cited to establish the publication date of another citation or other special reason (as specified) *O* document referring to an oral disclosure, use, exhibition or other means *P* document published prior to the international filing date but later than the priority date claimed *T* later document published after the international filing date or priority date and not in conflict with the application but cited to understand the principle or theory underlying the invention *X* document of particular relevance; the claimed invention cannot be considered novel or cannot be considered to involve an inventive step when the document is taken alone *Y* document of particular relevance; the claimed invention cannot be considered to involve an inventive step when the document is combined with one or more other such documents, such combination being obvious to a person skilled in the art. *&* document member of the same patent family		
Date of the actual completion of the international search 16 July 2009		Date of mailing of the international search report 27/07/2009
Name and mailing address of the ISA/ European Patent Office, P.B. 5818 Patentlaan 2 NL - 2280 HV Rijswijk Tel. (+31-70) 340-2040, Fax: (+31-70) 340-3016		Authorized officer Kakoullis, Marios

INTERNATIONAL SEARCH REPORT

International application No.
PCT/US2009/036175

Box No. II Observations where certain claims were found unsearchable (Continuation of item 2 of first sheet)

This international search report has not been established in respect of certain claims under Article 17(2)(a) for the following reasons:

1. Claims Nos.: 15-17
because they relate to subject matter not required to be searched by this Authority, namely:
Rule 39.1(iv) PCT - Method for treatment of the human or animal body by surgery
2. Claims Nos.:
because they relate to parts of the international application that do not comply with the prescribed requirements to such an extent that no meaningful international search can be carried out, specifically:
3. Claims Nos.:
because they are dependent claims and are not drafted in accordance with the second and third sentences of Rule 6.4(a).

Box No. III Observations where unity of invention is lacking (Continuation of item 3 of first sheet)

This International Searching Authority found multiple inventions in this international application, as follows:

1. As all required additional search fees were timely paid by the applicant, this international search report covers allsearchable claims.
2. As all searchable claims could be searched without effort justifying an additional fees, this Authority did not invite payment of additional fees.
3. As only some of the required additional search fees were timely paid by the applicant, this international search report covers only those claims for which fees were paid, specifically claims Nos.:
4. No required additional search fees were timely paid by the applicant. Consequently, this international search report is restricted to the invention first mentioned in the claims; it is covered by claims Nos.:

Remark on Protest

- The additional search fees were accompanied by the applicant's protest and, where applicable, the payment of a protest fee.
- The additional search fees were accompanied by the applicant's protest but the applicable protest fee was not paid within the time limit specified in the invitation.
- No protest accompanied the payment of additional search fees.

INTERNATIONAL SEARCH REPORT

Information on patent family members

International application No

PCT/US2009/036175

Patent document cited in search report	Publication date	Patent family member(s)	Publication date
US 2004049280	A1	11-03-2004	US 2004153159 A1 05-08-2004
US 5928284	A	27-07-1999	US 6231609 B1 15-05-2001
US 6419706	B1	16-07-2002	AT 269682 T 15-07-2004 AU 744241 B2 21-02-2002 AU 1767099 A 12-07-1999 CA 2315803 A1 01-07-1999 DE 69824759 D1 29-07-2004 DE 69824759 T2 30-06-2005 EP 1039855 A1 04-10-2000 ES 2222620 T3 01-02-2005 FR 2772594 A1 25-06-1999 WO 9932054 A1 01-07-1999 FR 2775891 A1 17-09-1999 JP 4046471 B2 13-02-2008 JP 2001526082 T 18-12-2001
WO 0004851	A	03-02-2000	AT 363877 T 15-06-2007 AU 748746 B2 13-06-2002 AU 5319399 A 14-02-2000 CA 2338379 A1 03-02-2000 DE 69936263 T2 04-10-2007 EP 1100416 A1 23-05-2001 ES 2286891 T3 01-12-2007 JP 2002521090 T 16-07-2002 US 7147665 B1 12-12-2006