

(No Model.)

F. W. ROBERTSHAW.  
LUBRICATOR.

2 Sheets—Sheet 1.

No. 526,503.

Patented Sept. 25, 1894.

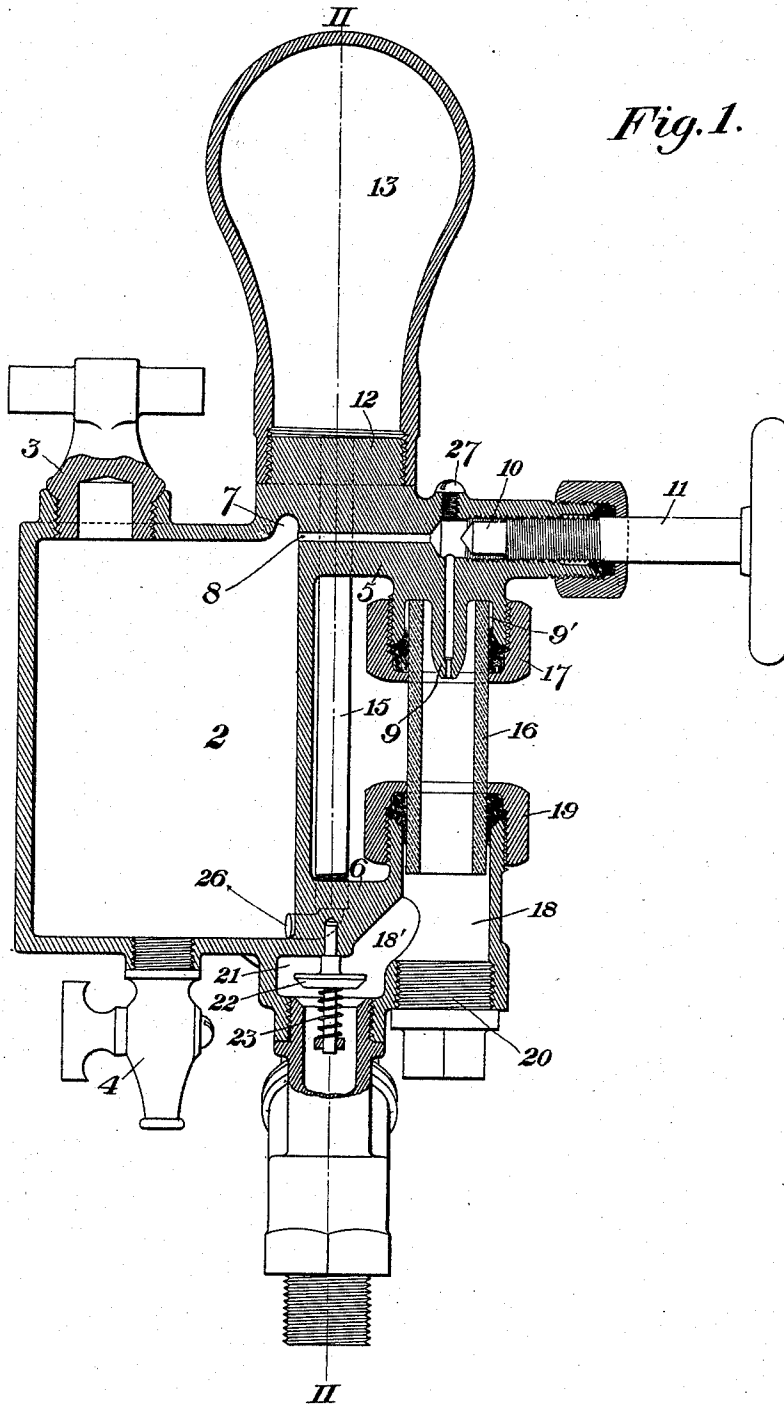

*Fig. 1.*

WITNESSES

*A. L. Gill.*  
*A. Byrnes.*

INVENTOR

*Frederick W. Robertshaw*  
*by W. Bakewell How*  
*his attorney*

(No Model.)

2 Sheets—Sheet 2.

F. W. ROBERTSHAW.  
LUBRICATOR.

No. 526,503.

Patented Sept. 25, 1894.

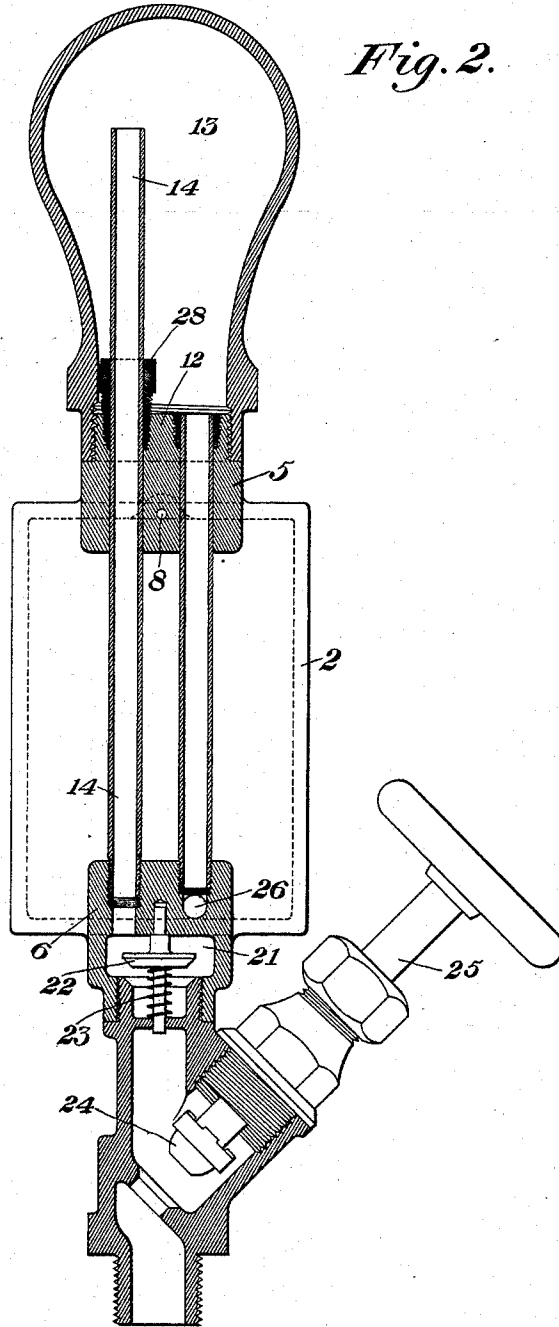

WITNESSES

*A. L. Gill.*  
*D. Byrnes.*

INVENTOR

*Frederick W. Robertshaw*  
*by T. R. Ackwell*  
*his attorney*

# UNITED STATES PATENT OFFICE.

FREDERICK W. ROBERTSHAW, OF PITTSBURG, PENNSYLVANIA.

## LUBRICATOR.

SPECIFICATION forming part of Letters Patent No. 526,503, dated September 25, 1894.

Application filed June 19, 1893. Serial No. 478,045. (No model.)

*To all whom it may concern:*

Be it known that I, FREDERICK W. ROBERTSHAW, of Pittsburg, in the county of Allegheny and State of Pennsylvania, have invented a new and useful Improvement in Lubricators, of which the following is a full, clear, and exact description, reference being had to the accompanying drawings, forming part of this specification, in which—

Figure 1 is a vertical central section of my improved lubricator; and Fig. 2 is a vertical section on the line II—II of Fig. 1.

My invention relates to the class of sight, drop feed lubricators, and is designed to improve their construction and remove certain difficulties incident to their use.

In the drawings, in which similar numerals indicate corresponding parts, 2 represents the oil reservoir, having a suitable filling-plug 3 and drain cock 4. Extending laterally from the upper and lower portions of this reservoir are two arms 5 and 6, which are preferably cast integral with the reservoir. The upper branch or arm 5 is provided with a recess 7 opening into the reservoir and from this recess a bent passage 8 leads to the oil-feeding nipple 9. In the bend of this passage a regulating needle valve 10 is carried upon a screw-threaded stem 11 working in an inner screw-threaded hole in the arm and carrying the usual handle at its outer end. Above this passage, upon the screw-threaded hub 12 of the arm, is secured the condenser 13 and into this condenser lead the steam-pipe 14 and the return pipe 15, both passing through vertical holes bored in the arm 5 on each side of the passage 8, as shown in Fig. 2. The pipe 14 is exposed to a high heat and pressure, and if rigidly secured in the arm 5 would become torn away by its expansion.

To provide an expansion joint I cut away the sides of the hole in the arm 5 to form an opening with inwardly converging sides and form screw threads therein. Into this opening is forced the hollow conical screw plug 28 which, as it moves downwardly around the pipe, is forced inward against its sides and both become wedged in place. The pipe, however, when it is heated and expands will slide through the hollow plug without injury to the parts. It is evident that this expansion joint will be useful in many connections.

An annular recess 9' is provided around the nipple 9 for the reception of the glass tube 16 whose end is surrounded by the packing ring 17. This tube leads downwardly into a chamber 18 in the lower arm 6, a similar packing ring 19 being provided at its lower end, and the lower end of the chamber 18 is closed by the screw-plug 20. From this chamber 18, the passage 18' leads to a second chamber 21, in which is provided the check-valve 22, which is normally held open by a surrounding spring 23, but is drawn down upon its seat by any back suction in the admission pipe. In the lower end of the chamber 21 is an inclined valve-seat for a stop-off valve 24, which is carried on an inclined spindle 25 projecting through the side of the chamber, and below this valve is the connection for the steam inlet pipe. The steam pipe 14 leads directly into the chamber 21, while the pipe 15 enters a curved passage 26 which leads into the lower end of the oil reservoir.

For cleaning the nipple 9 I provide a small aperture above the needle valve, this aperture being closed by the screw 27.

To start the lubricator, the filler plug 3 is removed and the steam-admission valve 24 slightly opened until steam escapes through the filling aperture. Then the valve is closed and the drain-valve opened to draw out any water in the reservoir. The reservoir is then filled with oil or melted tallow, the filling plug replaced, and the steam valve opened slightly. After a few moments the valve is fully opened and shortly thereafter the regulating valve 11 is opened and the flow of the oil adjusted thereby as desired. When thus in operation, the steam passes through the pipe 14 to the condenser, and being condensed upon its sides the resulting water descends through the tube 15 into the bottom of the reservoir and forces the oil, drop by drop, through the passage 8 and the nipple, whence it passes through chambers 18 and 21 to the steam chest.

The advantages of my construction result from the location of the tubes 14 and 15, which are exposed to the air but are protected from injury by being placed between the reservoir and tube, since I can connect closer to a steam pipe, engine or pump than has been heretofore possible, and can feed the oil hotter and use a very heavy oil if de-

sired. Moreover all the joints which are subject to leakage are exposed to view and easily reached, so that any leak is readily detected and remedied. The check-valve also is an important addition as it prevents the exhausting of the reservoir when steam is shut off from the cylinder, while the recess 7 admits of the complete exhaustion of oil from the reservoir after each filling.

10 Many changes may be made in the form and arrangement of the parts without departure from my invention, since

What I claim is—

15 1. In a sight-feed lubricator, the combination with the reservoir having arms leading from its upper and lower portions, a sight-feed tube carried thereby, a condenser secured to a projection on the upper arm, said arm having a bent passage leading through the  
20 arm to a feeding nipple on its lower side, a regulating valve passing through the outer end of said arm, and exposed steam and return pipes located between the reservoir and sight-tube; substantially as described.

25 2. In a sight-feed lubricator, the combina-

tion with the reservoir having two arms, a condenser secured to the upper arm, said arm having an oil-passage leading to a feeding nipple, and exposed steam and return pipes leading into the condenser through vertical holes in the upper arm on each side of the oil passage, said return pipe connecting with the reservoir; substantially as described. 30

3. In a sight-feed lubricator, the combination with the reservoir having arms leading from its upper and lower portions, a condenser secured to the upper arm, said arm having an oil-passage leading to a feeding nipple, an exposed steam pipe leading to the condenser, and an exposed return pipe leading from the condenser to the lower end of the reservoir, said steam and return pipes connecting the upper and lower arms; substantially as described. 40

In testimony whereof I have hereunto set my hand. 45

FREDERICK W. ROBERTSHAW.

Witnesses:

JOHN L. RALPH,  
C. BYRNES.