



(51) International Patent Classification:

G02B 26/08 (2006.01) G02B 27/42 (2006.01)
G01B 11/25 (2006.01) G02B 27/01 (2006.01)
G02B 27/09 (2006.01)

(21) International Application Number:

PCT/GB2017/000055

(22) International Filing Date:

10 April 2017 (10.04.2017)

(25) Filing Language:

English

(26) Publication Language:

English

(30) Priority Data:

62/390,781 11 April 2016 (11.04.2016) US

(71) Applicant: GRANT, Alastair, John [US/US]; 1460 Maria Way, San Jose, CA 95117 (US).

(72) Inventors; and

(71) Applicants : POPOVICH, Milan, Momcilo [GB/GB]; 53 Westfield Road, Leicester LE3 6HU (GB). WALDERN, Jonathan, David [US/US]; 11481 Old Ranch Road, Los Altos Hills, CA 94024 (US).

(81) Designated States (unless otherwise indicated, for every kind of national protection available): AE, AG, AL, AM,

AO, AT, AU, AZ, BA, BB, BG, BH, BN, BR, BW, BY, BZ, CA, CH, CL, CN, CO, CR, CU, CZ, DE, DJ, DK, DM, DO, DZ, EC, EE, EG, ES, FI, GB, GD, GE, GH, GM, GT, HN, HR, HU, ID, IL, IN, IR, IS, JP, KE, KG, KH, KN, KP, KR, KW, KZ, LA, LC, LK, LR, LS, LU, LY, MA, MD, ME, MG, MK, MN, MW, MX, MY, MZ, NA, NG, NI, NO, NZ, OM, PA, PE, PG, PH, PL, PT, QA, RO, RS, RU, RW, SA, SC, SD, SE, SG, SK, SL, SM, ST, SV, SY, TH, TJ, TM, TN, TR, TT, TZ, UA, UG, US, UZ, VC, VN, ZA, ZM, ZW.

(84) Designated States (unless otherwise indicated, for every kind of regional protection available): ARIPO (BW, GH, GM, KE, LR, LS, MW, MZ, NA, RW, SD, SL, ST, SZ, TZ, UG, ZM, ZW), Eurasian (AM, AZ, BY, KG, KZ, RU, TJ, TM), European (AL, AT, BE, BG, CH, CY, CZ, DE, DK, EE, ES, FI, FR, GB, GR, HR, HU, IE, IS, IT, LT, LU, LV, MC, MK, MT, NL, NO, PL, PT, RO, RS, SE, SI, SK, SM, TR), OAPI (BF, BJ, CF, CG, CI, CM, GA, GN, GQ, GW, KM, ML, MR, NE, SN, TD, TG).

Published:

— with international search report (Art. 21(3))



WO 2017/178781 A1

(54) Title: HOLOGRAPHIC WAVEGUIDE APPARATUS FOR STRUCTURED LIGHT PROJECTION

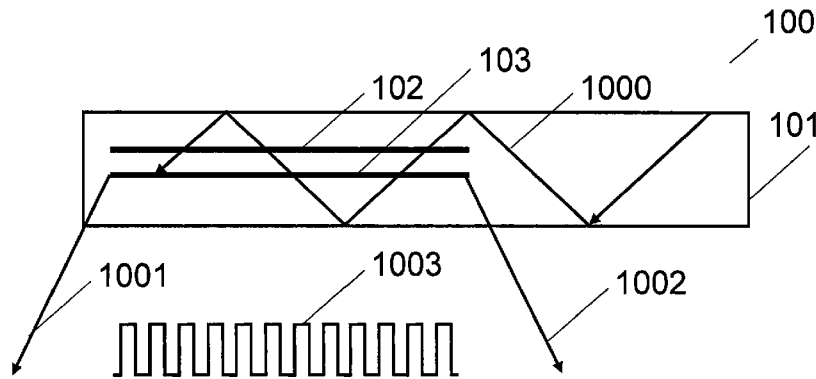

FIG. 1

(57) Abstract: A structured light projector comprising: a light source emitting light of a first wavelength; at least one switchable grating switchable between a non-diffracting and a diffracting state; and at least one passive grating. At least one of the switchable and passive gratings provides a first grating configuration for projecting uniform illumination in a first interval of time. At least one of the switchable and passive gratings provides a second grating configuration for projecting structured illumination in a second interval of time.

HOLOGRAPHIC WAVEGUIDE APPARATUS FOR STRUCTURED LIGHT PROJECTION

PRIORITY CLAIM

This application claims priority from US Provisional Application Serial No.: 62/390,781
5 entitled HOLOGRAPHIC WAVEGUIDE STRUCTURED LIGHT GENERATORS filed on 11
April 2016, which is hereby incorporated herein by reference in its entirety.

CROSS REFERENCE TO RELATED APPLICATIONS

The following patent applications are incorporated by reference herein in their entireties:

10 US Patent No. 9,075,184 entitled COMPACT EDGE ILLUMINATED DIFFRACTIVE
DISPLAY, , United States Patent No. 8,233,204 entitled OPTICAL DISPLAYS, PCT
Application No.: US2006/043938, entitled METHOD AND APPARATUS FOR PROVIDING A
TRANSPARENT DISPLAY, PCT Application No.: GB2012/000677 entitled WEARABLE
DATA DISPLAY, United States Patent Application No.: 13/317,468 entitled COMPACT
15 EDGE ILLUMINATED EYEGLASS DISPLAY, United States Patent Application No.:
13/869,866 entitled HOLOGRAPHIC WIDE ANGLE DISPLAY, and United States Patent
Application No.: 13/844,456 entitled TRANSPARENT WAVEGUIDE DISPLAY, United States
Patent Application No.:14/620,969 entitled WAVEGUIDE GRATING DEVICE, United States
Provisional Patent Application No.: 62/176,572 entitled ELECTRICALLY FOCUS TUNABLE
20 LENS, United States Provisional Patent Application No.: 62/177,494 entitled WAVEGUIDE
DEVICE INCORPORATING A LIGHT PIPE, United States Provisional Patent Application No.:
62/071,277 entitled METHOD AND APPARATUS FOR GENERATING INPUT IMAGES
FOR HOLOGRAPHIC WAVEGUIDE DISPLAYS,

PCT Application No.: PCT/GB2016/000005 entitled ENVIRONMENTALLY ISOLATED WAVEGUIDE DISPLAY, PCT Application No.: PCT/GB2013/000500 WAVEGUIDE FOR HOMOGENIZING ILLUMINATION, PCT Application No.: PCT/GB2014/000295 METHOD AND APPARATUS FOR CONTACT IMAGE SENSING, PCT Application No.:

5 PCT/GB2016/000005 HOLOGRAPHIC WAVEGUIDE LIGHT FIELD DISPLAYS, PCT Application No.: PCT/GB2016/000014 HOLOGRAPHIC WAVEGUIDE LIDAR, US Patent No. 8,224,133 entitled LASER ILLUMINATION DEVICE, US Patent No. US8, 565,560 entitled LASER ILLUMINATION DEVICE, United States Patent No. 6,115,152 entitled HOLOGRAPHIC ILLUMINATION SYSTEM, PCT Application No.: PCT/GB2013/000005

10 entitled CONTACT IMAGE SENSOR USING SWITCHABLE BRAGG GRATINGS, PCT Application No.: PCT/GB2012/000680, entitled IMPROVEMENTS TO HOLOGRAPHIC POLYMER DISPERSED LIQUID CRYSTAL MATERIALS AND DEVICES, PCT Application No.: PCT/GB2014/000197 entitled HOLOGRAPHIC WAVEGUIDE EYE TRACKER, PCT/GB2013/000210 entitled APPARATUS FOR EYE TRACKING, PCT

15 Application No.:GB2013/000210 entitled APPARATUS FOR EYE TRACKING, PCT/GB2015/000274 entitled HOLOGRAPHIC WAVEGUIDE OPTICALTRACKER, US Patent No. 8,903,207 entitled SYSTEM AND METHOD OF EXTENDING VERTICAL FIELD OF VIEW IN HEAD UP DISPLAY USING A WAVEGUIDE COMBINER, US Patent No. 8,639,072 entitled COMPACT WEARABLE DISPLAY, US Patent No. 8,885,112 entitled

20 COMPACT HOLOGRAPHIC EDGE ILLUMINATED EYEGLOSS DISPLAY, United States Provisional Patent Application No.: 62/284,603 entitled WAVEGUIDE DISPLAY, United States Provisional Patent Application No.: 62/285,275 entitled WAVEGUIDE DISPLAYS.

BACKGROUND OF THE INVENTION

The present disclosure relates to an illumination device and more particularly to a holographic waveguide device for producing structured illumination.

Waveguide optics is currently being considered for a range of display and sensor applications for which the ability of waveguides to integrate multiple optical functions into a thin, transparent, lightweight substrate is of key importance. Waveguides have also been proposed for sensor applications such as eye tracking, finger print scanning and LIDAR. US 9075184 B2 by Popovich et al, entitled "COMPACT EDGE ILLUMINATED DIFFRACTIVE DISPLAY, discloses a projection display device comprising: a light source, an SBG device comprising a multiplicity of separately SBG elements sandwich between transparent substrate to which transparent electrodes have been applied. The substrates function as a light guide. A least one transparent electrode comprises plurality of independently switchable transparent electrodes elements, each electrode element substantially overlaying a unique SBG element. Each SBG element encodes image information to be projected on an image surface. Light coupled into the light guide, undergoes total internal reflection until diffracted out to the light guide by an activated SBG element. The SBG diffracts light out of the light guide to form an image region on an image surface when subjected to an applied voltage via said transparent electrodes. The advantages of Bragg gratings (also referred to as a volume grating). in waveguide applications are well known. Bragg gratings have high efficiency with little light being diffracted into higher orders. The relative amount of light in the diffracted and zero order can be varied by controlling the refractive index modulation of the grating, a property which is used to make lossy waveguide gratings for extracting light over a large pupil. One important class of gratings is known as Switchable Bragg Gratings (SBG). SBGs are fabricated by first placing a thin film of a mixture

of photopolymerizable monomers and liquid crystal material between parallel glass plates. One or both glass plates support electrodes, typically transparent indium tin oxide films, for applying an electric field across the film. A volume phase grating is then recorded by illuminating the liquid material (often referred to as the syrup) with two mutually coherent laser beams, which
5 interfere to form a slanted fringe grating structure. During the recording process, the monomers polymerize and the mixture undergoes a phase separation, creating regions densely populated by liquid crystal micro-droplets, interspersed with regions of clear polymer. The alternating liquid crystal-rich and liquid crystal-depleted regions form the fringe planes of the grating. The resulting volume phase grating can exhibit very high diffraction efficiency, which may be
10 controlled by the magnitude of the electric field applied across the film. When an electric field is applied to the grating via transparent electrodes, the natural orientation of the LC droplets is changed causing the refractive index modulation of the fringes to reduce and the hologram diffraction efficiency to drop to very low levels. Typically, SBG Elements are switched clear in 30 μ s. With a longer relaxation time to switch ON. Note that the diffraction efficiency of the
15 device can be adjusted, by means of the applied voltage, over a continuous range. The device exhibits near 100% efficiency with no voltage applied and essentially zero efficiency with a sufficiently high voltage applied. In certain types of HPDLC devices magnetic fields may be used to control the LC orientation. In certain types of HPDLC phase separation of the LC material from the polymer may be accomplished to such a degree that no discernible droplet
20 structure results. A SBG may also be used as a passive grating. In this mode its chief benefit is a uniquely high refractive index modulation.

SBGs may be used to provide transmission or reflection gratings for free space applications. SBGs may be implemented as waveguide devices in which the HPDLC forms

either the waveguide core or an evanescently coupled layer in proximity to the waveguide. The parallel glass plates used to form the HPDLC cell provide a total internal reflection (TIR) light guiding structure. Light is coupled out of the SBG when the switchable grating diffracts the light at an angle beyond the TIR condition. Waveguides are currently of interest in a range of display and sensor applications. Although much of the earlier work on HPDLC has been directed at reflection holograms transmission devices are proving to be much more versatile as optical system building blocks. Typically, the HPDLC used in SBGs comprise liquid crystal (LC), monomers, photoinitiator dyes, and coinitiators. The mixture frequently includes a surfactant. The patent and scientific literature contains many examples of material systems and processes that may be used to fabricate SBGs. Two fundamental patents are: United States Patent No. 5,942,157 by Sutherland, and U. S Patent No. 5,751,452 by Tanaka et al. Both filings describe monomer and liquid crystal material combinations suitable for fabricating SBG devices. One of the known attributes of transmission SBGs is that the LC molecules tend to align normal to the grating fringe planes. The effect of the LC molecule alignment is that transmission SBGs efficiently diffract P polarized light (that is, light with the polarization vector in the plane of incidence) but have nearly zero diffraction efficiency for S polarized light (that is, light with the polarization vector normal to the plane of incidence. Transmission SBGs may not be used at near-grazing incidence as the diffraction efficiency of any grating for P polarization falls to zero when the included angle between the incident and reflected light is small.

Structured lighting is important in fields such as Augmented Reality (AR) for mapping the surrounding world in order that computer generated imagery can be integrated seamlessly. Current solutions tend to be based on conventional projectors which results in costly and bulky designs that are unsuitable for wearable applications. Some structured lighting approaches

required the ability to switched rapidly between structured illumination such as a grid pattern and continuous illumination. Efficient data processing requires that the effective source of the two illumination patterns is as close as possible to a point source. This is a difficult condition to meet with conventional projection devices.

5

There is a requirement for a low cost, efficient, structured light generator. There is a further requirement for low cost, efficient structured light generator that can switch rapidly between a structured light beam and a uniform illumination beam where the two beams have a substantially common effective source.

10

SUMMARY OF THE INVENTION

It is a first object of the invention to provide a low cost, efficient, structured light generator. It is a further objective of the invention to provide low-cost, efficient structured light generator that can switch rapidly between a structured light beam and a uniform illumination
15 beam where the two beams have a substantially common effective source.

The object of the invention is achieved in the embodiments of the invention described in the following specification with reference to the drawings. The objects of the invention are achieved in a first embodiment in which a structured light projector comprising: a light source
20 emitting light of a first wavelength; at least one switchable grating switchable between a non-diffracting and a diffracting state; and at least one passive grating. At least one of the switchable and passive gratings provides a first grating configuration for projecting uniform illumination in a first interval of time. At least one of the switchable and passive gratings provides a second

grating configuration for projecting structured illumination in a second interval of time. In some embodiments, the time intervals at least partially overlap. In some embodiments, the light source is provided by a laser or a LED.

5 In some embodiments, the second grating configuration comprises a passive or switchable grating encoding at least one of amplitude or phase modulation for forming the light into structured illumination.

In some embodiments, the second grating configuration comprises one of a passive or
10 switchable grating encoding a structured light pattern or a passive grating formed as a patterned mask.

In some embodiments, the second grating configuration is provided by two switchable gratings which in their diffracting states deflect light into beams which interfere to provide
15 structured illumination and the first grating configuration is provided by at least one of the switching gratings in its non-diffracting state.

In some embodiments, the first grating configuration is provided by a SBG in its non-diffracting state, wherein the second grating configuration is provided by the SBG in its
20 diffracting state and a passive transmission grating, wherein the passive transmission grating provides first order diffracted light and zero order light which interferes to provide structured illumination.

In some embodiments, the first grating configuration is provided by a SBG in its non-diffracting state, wherein the second grating configuration is provided by a passive transmission grating and a patterned mask, wherein the passive transmission grating diffracts first order diffracted light from the SBG in its diffracting state.

5

In some embodiments, the second grating configuration is provided by a SBG in its non-diffracting state and a patterned mask, wherein and the first grating configuration is provided by a passive transmission grating which diffracts first order diffracted light from the SBG in its diffracting state.

10

In some embodiments, a structured light projector according to the principles of the invention is disposed in a waveguide.

In some embodiments of a waveguide structured light projector, the second grating configuration comprises one of a grating encoding a structured light pattern or a combination of a switchable SBG deflector for deflecting the light out of the waveguide and a patterned mask applied to a surface of the waveguide for spatially modulating the light, wherein the first grating configuration is a passive SBG for deflecting the light out of the waveguide as uniform illumination.

20

In some embodiments of a waveguide structured light projector, further comprises an input coupler grating or an input coupler prism for admitting the light into the waveguide.

In some embodiments of a waveguide structured light projector, the first and second grating configurations are disposed in upper and lower waveguide layers respectively, wherein the first grating configuration comprises, disposed in the upper waveguide substrate, a switchable input grating coupler in its diffracting state and a switchable output grating coupler in its diffracting state, wherein the switchable input grating coupler in its diffracting states couples the light into the upper waveguide substrate and the switchable output grating coupler in its diffracting state deflects uniform illumination out of the upper waveguide substrate, wherein the lower waveguide substrate admits through the reflecting surfaces of the upper waveguide substrate when the upper waveguide substrate input grating coupler and output grating coupler are in their non-diffracting states.

In some embodiments of a waveguide structured light projector, the second grating configuration comprises disposed in a lower waveguide substrate a passive input grating coupler and a passive grating encoding a structure light pattern for deflecting structured illumination out of the lower waveguide substrate.

In some embodiments of a waveguide structured light projector, the second grating configuration comprises disposed in a lower waveguide substrate a passive input grating coupler, a passive grating deflector and a patterned mask for deflecting structured illumination out of the lower waveguide substrate.

In some embodiments of a waveguide structured light projector, the second grating configuration comprises disposed in a lower waveguide substrate a passive input grating coupler

and a passive structure of alternating passive grating regions and mirror regions for deflecting structured illumination out of the lower waveguide substrate.

In some embodiments of a waveguide structured light projector, the second grating configuration comprises disposed in a lower waveguide substrate a passive input grating coupler and a passive grating deflector and a patterned mask, a mirror and quarter wave plate configured for deflecting structured illumination of S and P polarizations out of the lower waveguide substrate.

In some embodiments, the switchable grating is one of a switchable Bragg grating, a switchable grating recorded in a holographic polymer dispersed liquid crystal material, or a switchable grating recorded in a reverse mode holographic polymer dispersed liquid crystal, and the passive grating is one of a surface relief grating, a Bragg grating, a grating recorded in a holographic polymer dispersed liquid crystal material or a patterned mask.

In some embodiments, at least one of the uniform or structure illuminations is shaped by one of a refractive, reflective or diffractive lens. In some embodiments, the structured light apparatus provides overlapping uniform and structured illumination beams

Following below are more detailed descriptions of various concepts related to, and embodiments of, an inventive holographic waveguide for use with unpolarized light. It should be appreciated that various concepts introduced above and discussed in greater detail below may be implemented in any of numerous ways, as the disclosed concepts are not limited to any

particular manner of implementation. Examples of specific implementations and applications are provided primarily for illustrative purposes. A more complete understanding of the invention can be obtained by considering the following detailed description in conjunction with the accompanying drawings, wherein like index numerals indicate like parts. For purposes of
5 clarity, details relating to technical material that is known in the technical fields related to the invention have not been described in detail.

BRIEF DESCRIPTION OF THE DRAWINGS

FIG.1 is a schematic side view of a waveguide structured light projector using switchable
10 gratings in one embodiment.

FIG.2 is a schematic side view of a waveguide structured light projector using a switchable grating and a grid mask in one embodiment.

FIG.3 is a schematic side view of a waveguide structured light projector using overlapping switchable gratings to provide structured light according to the principle of shearing
15 interferometry in one embodiment.

FIG.4A is a schematic side view of a first grating configuration of a structured light projector using overlapping switchable gratings in one embodiment.

FIG.4B is a schematic side view of a second grating configuration of a structured light projector using overlapping switchable gratings in one embodiment.

20 FIG.5A is a schematic side view of a first grating configuration of a structured light projector using overlapping switchable gratings in one embodiment.

FIG.5B is a schematic side view of a second grating configuration of a structured light projector using overlapping switchable gratings in one embodiment.

FIG.6A is a schematic side view of a second grating configuration of a structured light projector using overlapping switchable gratings in one embodiment.

FIG.6B is a schematic side view of a first grating configuration of a structured light projector using overlapping switchable gratings in one embodiment.

5 FIG.7A is a schematic side view of a second grating configuration of a waveguide structured light projector using a switchable grating and a grid mask in one embodiment.

FIG.7B is a schematic side view of a first grating configuration of a waveguide structured light projector using a switchable grating and a grid mask in one embodiment.

10 FIG.8A is a schematic side view of a second grating configuration of a waveguide structured light projector using a switchable grating, passive gratings and a grid mask in one embodiment.

FIG.8B is a schematic side view of a first grating configuration of a waveguide structured light projector using a switchable grating, passive gratings and a grid mask in one embodiment.

15 FIG.9 is a schematic side view of a waveguide structured light projector for providing first and second grating configurations comprising a switchable beam deflection grating and a switchable grating for encoding a structured light pattern in one embodiment.

FIG.10 is a schematic cross sectional view of the apparatus of FIG.9.

FIG.11A is a schematic side view of a second grating configuration of a waveguide structured light projector using a switchable beam deflection grating and a switchable grating for encoding a structured light pattern in one embodiment.

20 FIG.11B is a schematic side view of a first grating configuration of a waveguide structured light projector using a switchable beam deflection grating and a switchable grating for encoding a structured light pattern in one embodiment.

FIG.11C is a schematic side elevation view of a grating encoding diffusion properties for use in some embodiments of the invention.

FIG.12A is a schematic side view of a second grating configuration of a waveguide structured light projector using a switchable beam deflection grating and a switchable grating for encoding
5 a structured light pattern disposed in separate waveguide layers in one embodiment.

FIG.12B is a schematic side view of a first grating configuration of a waveguide structured light projector using a switchable beam deflection grating and a switchable grating for encoding a structured light pattern disposed in separate waveguide layers in one embodiment.

FIG.12C is a waveguide grating configuration comprising alternative grating and mirror
10 elements for use in some embodiments of the invention.

FIG.13A is a schematic side view of a second grating configuration of a structured light projector using switchable gratings in one embodiment.

FIG.13B is a schematic side view of a first grating configuration of a structured light projector using switchable gratings in one embodiment.

15 FIG.14A is a schematic side view of a first grating configuration of a waveguide structured light projector using a switchable beam deflection grating and a grid mask disposed in separate waveguide layers in one embodiment.

FIG.14B is a schematic side view of a second grating configuration of a waveguide structured light projector using a switchable beam deflection grating and a grid mask disposed in separate
20 waveguide layers in one embodiment.

FIG.15 is a schematic side view of a polarization recovery system for use with waveguide structured light projectors in some embodiments.

DETAILED DESCRIPTION OF THE INVENTION

The invention will now be further described by way of example only with reference to the accompanying drawings. It will appear to those skilled in the art that the present invention may be practiced with some or all of the present invention as disclosed in the following

5 description. For the purposes of explaining the invention well-known features of optical technology known to those skilled in the art of optical design and visual displays have been omitted or simplified in order not to obscure the basic principles of the invention. Unless otherwise stated the term “on-axis” in relation to a ray or a beam direction refers to propagation parallel to an axis normal to the surfaces of the optical components described in relation to the

10 invention. In the following description the terms light, ray, beam and direction may be used interchangeably and in association with each other to indicate the direction of propagation of electromagnetic radiation along rectilinear trajectories. The term light and illumination may be used in relation to the visible and infrared bands of the electromagnetic spectrum. Parts of the following description will be presented using terminology commonly employed by those skilled

15 in the art of optical design. It should also be noted that in the following description of the invention repeated usage of the phrase “in one embodiment” does not necessarily refer to the same embodiment.

The objects of the invention are achieved in a first embodiment in which a structured light projector comprises: a light source emitting light of a first wavelength; at least one

20 switchable grating switchable between a non-diffracting and a diffracting state; and at least one passive grating. At least one of the switchable and passive gratings provides a first grating configuration for projecting uniform illumination in a first interval of time. At least one of the switchable and passive gratings provides a second grating configuration for projecting structured

illumination in a second interval of time. In some embodiments, the second grating configuration comprises a passive or switchable grating encoding at least one of amplitude or phase modulation for forming the light into structured illumination. In some embodiments, the second grating configuration comprises one of a passive or switchable grating encoding a structured light pattern or a passive grating formed as a patterned mask. The invention does not assume any particular pattern geometry. However, for the purposes of explaining the invention a grid of parallel lines will be assumed. In some embodiments, a structured light projector according to the principles of the invention is disposed within in a waveguide. Most of the embodiments to be discussed in the following paragraphs can be implemented in waveguides. Waveguides offer the advantages of transparent, thin form factors and low cost fabrication and enable the integration of the structured light projector with other types of waveguide devices for providing display, eye tracking and LIDAR as disclosed in the reference documents. In some embodiments, the switchable grating is one of a switchable Bragg grating (SBG) as described above, a switchable grating recorded in a holographic polymer dispersed liquid crystal material, or a switchable grating recorded in a reverse mode holographic polymer dispersed liquid crystal, and the passive grating is one of a surface relief grating, a Bragg grating, a grating recorded in a holographic polymer dispersed liquid crystal material or a patterned mask. For the purposes of explaining the invention it will be assumed that the switchable grating is a SBG. In some embodiments, at least one of the uniform or structured illuminations is shaped by one of a refractive, reflective or diffractive lens. In some embodiments, the time intervals at least partially overlap. In some embodiments, the light source is provided by a laser or a LED. For the purposes of explaining the invention a laser will be assumed. In some embodiments, the waveguide may propagate light of more than one color. In some embodiments, the waveguide propagates infra-red. In some

embodiments, the structured light apparatus provides overlapping uniform and structured illumination beams.

In one embodiment 100 illustrated in FIG.1 there is provided a waveguide structured light projector comprising the waveguide 101, for propagating total internal reflection (TIR) light 1000, a switchable diffractive element 102 for diffracting light out of the waveguide as uniform illumination, and a switchable diffractive element 103 for forming a divergent beam represented by the rays 1001,1002 and characterized by a spatially modulated a structured light pattern 1003. In some embodiments, the waveguide is formed by sandwiched the grating layers between glass or plastic substrates to form a stack within which total internal reflection occurs at the outer substrate and air interfaces. The stack may further comprise additional layers such as beam splitting coatings and environmental protection layers. Switchable gratings will require that surfaces of the sandwiching substrates are coated with a transparent electrode. Advantageously, to minimizes the switching fields opposing substrate surfaces are coated. For the purposes of explaining the inventions we shall consider a waveguide containing a single grating layer operating in monochrome. However, the invention may be applied to waveguide devices comprising more than one layer. It is assumed that entire grating shown in FIG.1 switches ON/OFF. In some embodiments, the waveguide may be based on the embodiments and teachings of United States Patent US 9075184 B2 by Popovich et al entitled "Compact edge illuminated diffractive display". The patent discloses a projection display device comprising: a light source, an SBG device comprising a multiplicity of separately SBG elements sandwich between transparent substrate to which transparent electrodes have been applied. The substrates function as a light guide. A least one transparent electrode comprises plurality of independently switchable transparent electrodes elements, each electrode element substantially overlaying a

unique SBG element. Each SBG element encodes image information to be projected on an image surface. Light coupled into the light guide, undergoes total internal reflection until diffracted out to the light guide by an activated SBG element. The SBG diffracts light out of the light guide to form an image region on an image surface when subjected to an applied voltage via said

5 transparent electrodes.

In some embodiments such as the one of FIG.2 a structured light projector 110 comprises a waveguide 111 for propagating TIR light 1010 containing at least one array of switchable diffractive elements such as 112,113 disposed in a layer, each element having a unique grating vector (or K-vector). In a Bragg grating the K-vector is normally defined as the vector normal to the Bragg fringe surfaces. In some embodiments, the K-vectors vary in discrete steps. In some 10 embodiments continuously rolled K-vectors may be used. The spatially-varying (rolled) K-vectors allow the effective angular bandwidth of the waveguide to be increased enabling a wider angle structured light beam. A coating formed as a grid 113 is applied to the output surface of the waveguide to spatially modulate the output light. Light diffracted out of the waveguide by the 15 gratings 112,113 in their diffracting states is modulated by the grid 113 to form the structure light beam portions indicated by 1012,1013. The invention places no limits on the number of grating elements or the number of grating layers. In some embodiments which do not required wide angle coverage, the number of grating elements may be reduced to just one.

In some embodiments such as the one illustrated in FIG.3 a structured light projector 120 20 comprises a waveguide 121 for propagating TIR light 1020 containing arrays of switchable diffractive elements such as 122,123 disposed in an upper layer and 124,125 in a lower layer. In some embodiments, each grating element has a unique K-vector to increase the angular coverage of the projector. The structured light is formed by interfering beams diffracted from

overlapping grating elements, for example the beams 1021,1022 diffracted by the overlapping grating elements 123,125. By making relative angle between the beam wavefronts small the interference fringes 1023 are formed according to the principles of shearing interferometry which are discussed in standard texts on interferometry. The grid column angular width depends on the relative displacement (shear) of the gratings. Some balancing of the diffraction efficiencies of the two grating layers may be required to achieve optimal fringe contrast. The effective source separation, s , of the two diffracted beams required to achieve a grid angular resolution $\delta\theta$ is approximately $s \sim \lambda / \delta\theta$ where λ is the wavelength.

In some embodiments such as the one shown in FIG.4A and FIG.4B a structured light projector 130 forms a structured light pattern by interfering the zeroth order and first order diffracted light from a SBG. Uniform illumination is provided when the SBG is in its non-diffracting state (FIG.4A) and structure illumination is provided with the SBG in its diffracting state. Turning first to FIG.4A, the structured light projector in a first grating configuration comprises a first substrate 131 containing a switchable grating 132A in its non-diffracting state and a second substrate 133 containing a switchable grating 134A in its non-diffracting state. The apparatus further comprises a source 135 emitting light 1030 which is collimated into the beam 1031 by the lens 136 and a projection lens 137 for forming the divergent uniform illumination beam 1032. The precise specification of the lens, which may comprise multiple elements, will depend on the source and the required beam geometry. Advantageously, the beam will be collimated to enable high diffraction efficiency of the gratings. [The source optics may also comprise filters, apertures and other optical components for controlling beam geometry and the illumination profile. In some embodiments using laser sources the lens 136 may be an afocal beam expander. Turning next to FIG.4B which shows the structured light projector in a second

grating configuration, the switchable gratings in the first and second substrates now labelled as 132B, 134B are now both in tier diffracting states. The efficiency of the grating 123A is designed to provide diffracted and zero orders of similar intensity. The two gratings are designed such that the zero-order light lies outside the diffraction efficiency angular bandwidth of the grating 132B and hence proceeds through it would significant deviation and is expanded by the projection lens into divergent uniform illumination n 1034. Diffraction efficiency angular bandwidth is normally defined by the full width half maximum of the diffraction efficiency versus angle distribution. However other measure may be used for purposes of implementing the invention. The diffracted light which propagates in the direction 1033 is within the diffraction efficiency angular bandwidth of the grating 132B. After diffraction by the grating 132B the light is expanded by the projection lens to form the divergent uniform illumination 1035 which has a small lateral or angular separation from the illumination 1034. The two output beams interfere according to the principles of shearing interferometry to form the fringe pattern 1036.

In some embodiments of a waveguide structured light projector, the second grating configuration comprises one of a grating encoding a structured light pattern or a combination of a switchable SBG deflector for deflecting the light out of the waveguide and a patterned mask applied to a surface of the waveguide for spatially modulating the light, wherein the first grating configuration is a passive SBG for deflecting the light out of the waveguide as uniform illumination.

In some embodiments such as the one shown in FIG.5A and FIG.5B a structured light projector using a SBG, a passive grating and a patterned mask all disposed in different layers. FIG.5A illustrates the first grating configuration which forms uniform divergent illumination and FIG.5B illustrates the second grating configuration which forms structured divergent

illumination. Turning first to FIG.5A, the apparatus comprises a source and lens for forming the collimated beam 1040, a first substrate containing a switchable grating 148A in its diffracting state, a second substrate 142 and a third substrate containing a passive grating 149, a fourth substrate 146 with a grid mask 147 applied to a portion of a surface substantially overlapping the grating 149. The fourth substrate must be thick enough to allow an unobstructed diffracted beam path. The apparatus further comprises two projection lenses, the first 144 of which lies in the beam path 1040 and the second 145 overlays the grating 149. The invention does not assume any particular type of projection lens. The beam is projected into the divergent uniform divergent illumination 1041 passing through the fourth substrate 147. In some embodiments, the projection lenses may comprise systems of refractive elements. In some embodiments, the projection lenses may comprise diffractive elements. In some embodiments, the projection lenses may be formed as diffractive structures formed in the output surface of the fourth substrate. Turning to FIG.5B we see that with the SBG in its diffractive state 148B incident collimated light is diffracted into the direction 1042. After diffraction by the passive grating 149 the beam is projected into a divergent beam 1043 which is spatially modulated by the grid 147 to form the structured illumination 1044. Owing to the need to accommodate two projection lenses this embodiment requires the uniform and structured illumination to be offset from each other.

FIG.6A and FIG.6B illustrate an embodiment 150 similar to the one of FIG.5A and FIG.5B. A structured light projector a SBG, a passive grating and a patterned mask with the passive grating and patterned mask disposed in a common substrate. Using the terminology introduced above FIG.6A illustrates the second grating configuration which forms uniform divergent illumination and FIG.6B illustrates the first grating configuration which forms structured divergent illumination. Turning first to FIG.6A, the apparatus comprises a source 151

and lens 152 for forming the collimated beam 1050, a first substrate 154A containing a switchable grating 158A in its non-diffracting state, a second substrate 154B and a third substrate 154C containing a passive grating 15 and a grid mask 155 overlapping the grating 158A. The substrate 154B must be thick enough to allow an unobstructed diffracted beam path. The apparatus further comprises two projection lenses, the first 156 of which lies in the beam path 1040 and the second 157 overlays the grating 159. The collimated light 1050 passes through the grating 158A without deviation undergoes spatial modulation at the grid 155 and is projected by the lens 156 into the divergent structured illumination 150. Turning to FIG.6B the SBG in its diffractive state 158B diffracts incident collimated light into the direction 1053. After diffraction by the passive grating 159 the beam is projected into a divergent beam 1059 which is projected by the lens 157 to form the uniform illumination 1054. Owing to the need to accommodate two projection lenses this embodiment requires the uniform and structured illumination to be offset from each other.

FIG.7A and FIG.7B illustrate first and second grating configurations of a structured light projector 160 using a waveguide architecture. FIG.7A illustrates a second grating configuration which forms structured divergent illumination and FIG.7B illustrates a first grating configuration which forms uniform divergent illumination. Referring to FIG.7A, the apparatus comprises a source and beam collimation and expansion lens system for forming the collimated beam 1060, a coupling prism for introducing the beam into a TIR path 1061 within a waveguide formed from upper and lower substrates 161A, 161B sandwiching a switchable grating in its diffracting state 163A. The upper substrate supports a grid mask 164 overlapping the switchable grating and a passive grating 165. A first projection lens 166 overlays the grid mask. Advantageously, the grid mask is at the focal surface of the first projection lens. A second projection lens 167 overlays the

passive grating 165. The switchable grating in its diffracting state diffracts light onto the grid mask which spatially modulates the light which is then formed in a divergent beam 1063 providing structured light 1064 by the projection lens 166. In the first grating configuration illustrated in FIG.7B the switchable grating is in its non-diffracting state 163B. The TIR light 1065 is transmitted down the waveguide until it interacts with the passive grating 165 and is formed into uniform divergent beam 1067 by the projection lens 164. In some embodiments, the passive grating is a surface relief diffractive structure. In some embodiments, the passive grating is a Bragg grating.

FIGS.8A and FIG.8B show first and second grating configurations of a structured light projector embodiment 170 similar to the one of FIGS.7A and FIG.7B. The key differences, referring to FIG.8A, are the use of two 45-degree prism 179A,179C, mounted around an afocal beam expansion optics 179B, and a passive input grating coupler 173 to couple collimated light 1070 from a laser module 171B into the TIR path 1071. The laser module is mounted on a platform 176. In some embodiments, other mounting arrangements may be used for supporting the laser module. The apparatus further comprises a passive output grating 175A in its diffracting state diffracting TIR light 1071 through a grid mask 178 which spatially modulates the light before it is projected into the divergent beam 1073 providing the structured illumination 1074. The apparatus further comprises the passive output grating 172A and the diffractive projection lens 171A. In the first grating configuration illustrated in FIG.8B the switchable grating is in its non-diffracting state 174B. The TIR light 1075 is transmitted down the waveguide until it interacts with the passive grating and is formed into uniform divergent beam 1076 by the diffractive projection lens.

FIGS.9-10 show orthogonal elevation views of a structured light projector embodiment 180. The apparatus comprises a laser module 181 mounted on a platform 182 a waveguide from upper and lower contacting substrates 183A,183B the upper substrate containing the input grating 184 and a switchable output grating 183A for deflecting TIR light to form uniform illumination when in its diffracting state. The lower substrate contains a switchable output grating 183B encoding a prescription for forming a structured illumination pattern when in its diffracting state. The two output gratings substantially overlap. The apparatus further comprises a first 45-degree prism 187A an afocal magnifier 187B and a second 45-degree prism 187C for coping collimated light into the waveguide. The apparatus further comprises a projection lens 188.

FIGS.11A,11B show the second and first grating configurations of a structured light projector 190. The apparatus comprises a laser module, which is not illustrated, a waveguide substrate 191 containing an input grating 192, a switchable output grating 194B for deflecting TIR light to form uniform illumination when in its diffracting state and a switchable output grating 194A encoding a prescription for forming a structured illumination pattern when in its diffracting state. The two output gratings substantially overlap. The apparatus further comprises a projection lens 195. In the second grating configuration shown in FIG.11A the switchable grating 194A is in its diffracting state modulating the illumination which is projected into a divergent beam 1093 with structured illumination 1094. The switchable grating 194B is in its non-diffracting state when the grating 194A is in its diffracting state. In some embodiments, the grating 194A may also encode diffusing properties as indicated in FIG.11C which shows the switchable grating 193 the input TIR ray direction and the average diffracted beam direction 1096. The extent of the diffused beam cone is indicated by the dashed rays 1097. Diffusing the

output from the grating provides a diffuse grid input image for the projection lens. Output gratings incorporating diffusing properties may be used in any of the embodiments of the invention. Turning to FIG.11B, in the first grating configuration the switchable grating 194A is in its non-diffracting state when the grating 194B is in its diffracting state forming the divergent uniform illumination 1099.

FIGS.12A,12B illustrate the second and first grating configurations of a structured light projector 200. Referring to FIG.12A the apparatus comprises upper and lower optically isolated waveguides 201A,201B. In some embodiments, the optical isolation is provided by an air gap. In some embodiments, the optical isolation is provided by a low refractive index such as a nano-porous material. The upper waveguide contains an input switchable grating 202A in its diffracting state and an output switchable grating encoding a structured light pattern 203A in its diffracting state. The input switchable grating couples input collimated light 1100 into the TIR beam 1101. Diffracted light 1102 extracted from the upper waveguide by the output grating s is projected by the projection lens 206 into the divergent beam 1103 forming structured illumination 1104. The lower waveguide contains the passive input and output gratings 204,205 which substantially overlap the gratings 202A,203A. Turning to FIG.12B, when the gratings in the upper grating are in their non-diffracting states 202A,203A light couple into the upper waveguide are transmitted without deviation through the first switchable grating into the lower waveguide. The light is diffracted into the lower waveguide TIR path 1105 by the grating 204 and diffracted out of the lower waveguide by the grating 205 into the upper waveguide where it passes through the grating 203B without substantial deviation and is projected by the projection lens into the divergent uniform illumination 1107. As discussed above switchable gratings such as SBGs are polarization selective which makes them compatible with laser sources. However,

in the case of unpolarized sources such as LEDs there is potentially at least 50% throughput loss.

In some embodiments based on the embodiment of FIGS. 112A-12B the grating 205 encodes a structured light pattern and the output grating is a switching grating providing beam deflection (without light modulation) when in its diffracting state. Hence the upper grating provides the

5 first grating configuration and the lower grating provides the second grating configuration.

FIG. 12C illustrates a waveguide device 210 comprising alternating mirror and grating elements which offers an alternative the use of a grating mask in some embodiments. A disadvantage of grating masks in waveguide architectures is that much of the TIR light striking the underside of the non-transmitting regions of the mask does not contribute to the structured
10 illumination. the embodiment 210 of FIG. 12C allows most of the guide light to be extracted as as structured light. The apparatus comprises a waveguide portion with reflecting surface 211A, 211B containing an array comprising alternating grating elements 212, 214, 216 and mirror elements 213, 215. The mirror elements have reflective upper and lower surfaces. The gratings serve to diffract light upwards as in the case of the ray 113. Downward propagating light striking
15 a mirror element is reflected and undergoes a further TIR reflection surface at the upper waveguide surface 211A and then passes through the grating element without diffraction as the ray lies outside the diffraction efficiency angular bandwidth. The ray undergoes TIR at the lower waveguide surface 211B and when interacting with the next grating element is diffracted upwards as the ray 1114. Downward propagating TIR light reflected from a surface point A
20 striking mirror element 213 is reflected at the surface point B on the upper waveguide surface 211A and undergoes a further TIR reflection and then passes through the grating element 214 without diffraction as the ray lies outside the diffraction efficiency angular bandwidth. The ray undergoes TIR at point E on the lower waveguide surface 211B, is reflected at the underside of

mirror element 215, undergoes a further TIR at point F on the lower waveguide surface 211B and when interacting with the grating element 216 is diffracted upwards as the ray 1114. Upward propagating TIR light reflected from a point C on the lower waveguide surface 211B undergoes reflection at the lower surface of the mirror element 213, undergoes TIR at the point D on the lower waveguide surface and when interacting with the grating element 214 is diffractive upwards as the ray 1115. The gratings elements are passive elements and in some embodiments, are Bragg gratings. In some embodiments, the apparatus of FIG.12C replaces the grating mask disclosed in relation to the above described embodiments. In some embodiments such as the one shown in the mirror and grating array of FIG.12C may be disposed on the bottom surface of the lower waveguide.

FIG.13A and FIG.13B illustrate the second and first grating configurations of a structured light projector 220 using two switchable gratings arranged in series along an optical path. In the second grating configuration, the first grating is in its diffracting state 221A diffracting incident collimated light 1120 into the direction 1121 with high efficiency. The second grating which is also in its diffracting state 222A diffracts light into diffracted (+1) indicated by 1122 and zero order (0) light indicated by 1123, the grating prescription being design to provide equal intensities in the two beams. The diffracted and zero order light interfere to form the structured light 1124. In the first grating configuration, the first and second gratings are in their non-diffracting states 221B, 222B allowing incident light to propagate without substantial deviation or attenuation resulting in the uniform illumination 1127. In some embodiments, the apparatus of FIGS.31A-13B is configured within a waveguide.

FIG.14A and FIG.14B illustrate the first and second configurations of a structured light projector 230 using optically isolated waveguides. The apparatus is similar to that of the

embodiment of FIGS.12A and FIG.12B. However, the switching grating encoding structured light pattern used as the output grating of the upper waveguide now provides beam deflection without light modulation. The latter is provided by a grid mask disposed above and overlapping the output grating of the lower waveguide. Referring first to FIG.14A the apparatus comprises upper and lower optically isolated waveguides 231A,231B. The upper waveguide contains an input switchable grating 232A in its diffracting state and an output switchable grating encoding a structured light pattern 233A in its diffracting state. The input switchable grating couples input collimated light 1130 into the TIR beam 1131. Diffracted light 1132 extracted from the upper waveguide by the output grating is projected by the projection lens 238 into the divergent beam 1133 forming uniform illumination. The lower waveguide contains the passive input and output gratings 234,235 which substantially overlap the gratings 232A,233A. Turning to FIG.14B, when the gratings in the upper grating are in their non-diffracting states 232A,233A light 1130 is coupled into the upper waveguide and is transmitted without deviation through the first switchable grating into the lower waveguide. The light is diffracted into the lower waveguide TIR path 1135 by the passive grating 234 and diffracted out of the lower waveguide by the passive grating 235, through the grid mask 239, into the upper waveguide where it passes through the grating 233B in its non-diffracting state without substantial deviation and is projected by the projection lens into the divergent beam 1138 providing the structure illumination 1139.

In some embodiments, the structured light projector based on waveguides incorporates a means for recycling illumination. Ordinarily a mask with equal clear and opaque stripe widths will incur a throughput loss. For example, a mask which has equal clear and opaque stripe widths incurs at least 50% throughput loss. The embodiment 250 shown in FIGS.15 comprises

the substrates 251,252, a mirror coating applied to the lower surface of the substrate 251 a transmission grating 254 disposed within the substrate 251, a quarter wavelength film 255 sandwiched by substrates 251,252 overlapping the grating and a grid mask 256 also overlapping the grating. P-polarized TIR illumination 1150 is reflected off the lower surface of substrate 251 and diffracted upwards through the quarter waveplate which converts it to first sense circularly polarized light 1054 propagating in directions 1151 and 1153. Approximately half of this light is reflected downwards by the grid mask and is converted to second sense circularly polarized light 1055 which after passing through the quarter waveplate becomes S-polarized. On reflection at the mirror the S-polarized light passes through the grating without deviation since the grating has low efficiency for S-polarized light. The light is again converted from linear to circular polarization by the quarter wave plate and approximately half of it is extracted from the waveguide via the grid mask. Potentially, this recycling scheme could allow about 75% of the available light to be used for pattern projection.

In some embodiments, the waveguide gratings discussed above may be based on surface relief structures. In some embodiments using grid transparencies to provide structured illumination the grid pattern may be pre-distorted to compensate for the distortion introduced by the projection lens. For example, in some embodiments the grid may be pre-distorted with barrel distortion to compensate for the pincushion distortion of the projection lens.

In some embodiments, the grid mask is fabricated using a chromium mask overlaying the top substrate of a waveguide with the mask exactly overlapping the output grating. In some embodiments, other materials such as silver, gold or aluminum may be used to fabricate the mask. The mask will be produced using a standard mirror deposition and masking process.

In some embodiments, the output grating in a waveguide will combine the functions of beam deflection and diffusion. The two waveguides will be separated by a small air gap to ensure complete optical isolation.

In some embodiments, a stock lens of size and prescription similar that required for mobile device cameras may be used to provide a projection lens. In some embodiments, a diffractive or hybrid diffractive–refractive lens may be used. In some embodiments, the grating angular characteristics can be fine-tuned by varying the grating vectors. In some embodiments, the illumination at the edges of the field of view may be increased at the expense of the illumination near the center of the field. In some embodiments, the required illumination profile is encoded into the output gratings along with the basic beam steering and diffusion functions.

It is well established in the literature of holography that more than one holographic prescription can be recorded into a single holographic layer. Methods for recording such multiplexed holograms are well known to those skilled in the art. In some embodiments, at least one of the input, fold or output gratings may combine two or more angular diffraction prescriptions to expand the angular bandwidth. Similarly, in some embodiments at least one of the input or output gratings may combine two or more spectral diffraction prescriptions to expand the spectral bandwidth. For example, a color multiplexed grating may be used to diffract two or more of the primary colors.

In most waveguide configurations, the gratings are formed in a single layer sandwiched by transparent substrates. In some embodiments, the waveguide may comprise just one grating layer. In some embodiments, the cell substrates may be fabricated from glass. An exemplary glass substrate is standard Corning Willow glass substrate (index 1.51) which is available in

thicknesses down to 50 microns. In other embodiments, the cell substrates may be optical plastics.

In some embodiments, the grating layer may be broken up into separate layers. For example, in some embodiments, a first layer includes the input grating while a second layer includes the output grating. The number of layers may then be laminated together into a single waveguide substrate. In some embodiments, the grating layer is comprised of a number of pieces that are laminated together to form a single substrate waveguide. The pieces may be separated by optical glue or other transparent material of refractive index matching that of the pieces. In another embodiment, the grating layer may be formed via a cell making process by creating cells of the desired grating thickness and vacuum filling each cell with SBG material for each grating. In one embodiment, the cell is formed by positioning multiple plates of glass with gaps between the plates of glass that define the desired grating thickness. In one embodiment, one cell may be made with multiple apertures such that the separate apertures are filled with different pockets of SBG material. Any intervening spaces may then be separated by a separating material (e.g., glue, oil, etc.) to define separate areas. In one embodiment, the SBG material may be spin-coated onto a substrate and then covered by a second substrate after curing of the material.

In another embodiment, the gratings can be created by interfering two waves of light at an angle within the substrate to create a holographic wave front, thereby creating light and dark fringes that are set in the waveguide substrate at a desired angle. In some embodiments, the grating in a given layer is recorded in stepwise fashion by scanning or stepping the recording laser beams across the grating area. In some embodiments, the gratings are recorded using mastering and contact copying process currently used in the holographic printing industry.

In one embodiment, the gratings embodied as SBGs can be Bragg gratings recorded in a holographic polymer dispersed liquid crystal (HPDLC) (e.g., a matrix of liquid crystal droplets), although SBGs may also be recorded in other materials. In one embodiment, SBGs are recorded in a uniform modulation material, such as POLICRYPS or POLIPHEN having a matrix of solid liquid crystals dispersed in a liquid polymer. The SBGs can be switching or non-switching in nature. In its non-switching form an SBG has the advantage over conventional holographic photopolymer materials of being capable of providing high refractive index modulation due to its liquid crystal component. Exemplary uniform modulation liquid crystal-polymer material systems are disclosed in United State Patent Application Publication No.: US2007/0019152 by Caputo et al and PCT Application No.: PCT/EP2005/006950 by Stumpe et al. both of which are incorporated herein by reference in their entireties. Uniform modulation gratings are characterized by high refractive index modulation (and hence high diffraction efficiency) and low scatter.

In one embodiment, the gratings are recorded in a reverse mode HPDLC material. Reverse mode HPDLC differs from conventional HPDLC in that the grating is passive when no electric field is applied and becomes diffractive in the presence of an electric field. The reverse mode HPDLC may be based on any of the recipes and processes disclosed in PCT Application No.: PCT/GB2012/000680, entitled IMPROVEMENTS TO HOLOGRAPHIC POLYMER DISPERSED LIQUID CRYSTAL MATERIALS AND DEVICES. The gratings may be recorded in any of the above material systems but used in a passive (non-switching) mode. The fabrication process is identical to that used for switched but with the electrode coating stage being omitted. LC polymer material systems are highly desirable in view of their high index modulation. In some embodiments, the gratings are recorded in HPDLC but are not switched.

In some embodiments, the input grating may be replaced by another type of input coupler such as a prism, or reflective surface. In some embodiments, the input coupler can be a holographic grating, such as a switchable or non-switchable SBG grating.

In some embodiments. In some embodiments, the output gratings are configured to provide pupil expansion in a second direction different than the first direction and to cause the light to exit the waveguide from the first surface or the second surface. In some embodiments, the output grating consists of multiple layers of substrate, thereby comprising multiple layers of output gratings. Accordingly, there is no requirement for gratings to be in one plane within the waveguide, and gratings may be stacked on top of each other (e.g., cells of gratings stacked on top of each other).

In some embodiments, a quarter wave plate on the substrate waveguide rotates polarization of a light ray to maintain efficient coupling with the SBGs. The quarter wave plate may be coupled to or adhered to the surface of waveguide. For example, in one embodiment, the quarter wave plate is a coating that is applied to substrate waveguide. The quarter wave plate provides light wave polarization management. Such polarization management may help light rays retain alignment with the intended viewing axis by compensating for skew waves in the waveguide. The quarter wave plate is optional and can increase the efficiency of the optical design in some embodiments. The quarter wave plate may be provided as multi-layer coating.

In some embodiments, the structured light projector forms part of an eye tracked display comprising a waveguide display and an eye tracker. In one preferred embodiment, the eye tracker is a waveguide device based on the embodiments and teachings of PCT/GB2014/000197 entitled HOLOGRAPHIC WAVEGUIDE EYE TRACKER, PCT/GB2015/000274 entitled

HOLOGRAPHIC WAVEGUIDE OPTICAL TRACKER, and PCT Application

No.:GB2013/000210 entitled APPARATUS FOR EYE TRACKING.

It should be emphasized that the drawings are exemplary and that the dimensions have been exaggerated. For example, thicknesses of the SBG layers have been greatly exaggerated.

5 Optical devices based on any of the above-described embodiments may be implemented using plastic substrates using the materials and processes disclosed in PCT Application No.:

PCT/GB2012/000680, entitled IMPROVEMENTS TO HOLOGRAPHIC POLYMER
DISPERSED LIQUID CRYSTAL MATERIALS AND DEVICES. In some embodiments, the
dual expansion waveguide display may be curved.

10 The construction and arrangement of the systems and methods as shown in the various exemplary embodiments are illustrative only. Although only a few embodiments have been described in detail in this disclosure, many modifications are possible (for example, variations in sizes, dimensions, structures, shapes and proportions of the various elements, values of parameters, mounting arrangements, use of materials, colors, orientations, etc.). For example,
15 the position of elements may be reversed or otherwise varied and the nature or number of discrete elements or positions may be altered or varied. Accordingly, all such modifications are intended to be included within the scope of the present disclosure. The order or sequence of any process or method steps may be varied or re-sequenced according to alternative embodiments. Other substitutions, modifications, changes, and omissions may be made in the design, operating
20 conditions and arrangement of the exemplary embodiments without departing from the scope of the present disclosure.

CLAIMS

What is claimed:

- 5 1. A structured light projector comprising:
- a light source emitting light of a first wavelength;
 - at least one switchable grating switchable between a non-diffracting and a diffracting state;
 - and
 - at least one passive grating,
- 10 at least one of said switchable and passive gratings providing a first grating configuration for projecting uniform illumination in a first interval of time,
- at least one of said switchable and passive gratings providing a second grating configuration for projecting structured illumination in a second interval of time.
- 15 2. The apparatus of claim 1 wherein said second grating configuration comprises a passive or switchable grating encoding at least one of amplitude or phase modulation for forming said light into structured illumination.
3. The apparatus of claim 1 wherein said second grating configuration comprises one of a
- 20 passive or switchable grating encoding a structured light pattern or a passive grating formed as a patterned mask.

4. The apparatus of claim 1 wherein said second grating configuration is provided by two switchable gratings which in their diffracting states deflect light into beams which interfere to provide structured illumination and said first grating configuration is provided by at least one of said switching gratings in its non-diffracting state.

5

5. The apparatus of claim 1 wherein said first grating configuration is provided by a SBG in its non-diffracting state, wherein said second grating configuration is provided by said SBG in its diffracting state and a passive transmission grating, wherein said passive transmission grating provides first order diffracted light and zero order light which interferes to provide structured illumination.

10

6. The apparatus of claim 1 wherein said first grating configuration is provided by a SBG in its non-diffracting state, wherein said second grating configuration is provided by a passive transmission grating and a patterned mask, wherein said passive transmission grating diffracts first order diffracted light from said SBG in its diffracting state.

15

7. The apparatus of claim 1 wherein said second grating configuration is provided by a SBG in its non-diffracting state and a patterned mask, wherein and said first grating configuration is provided by a passive transmission grating which diffracts first order diffracted light from said SBG in its diffracting state.

20

8. The apparatus of claim 1 disposed in a waveguide.

9. The apparatus of claim 8 wherein said second grating configuration comprises one of a grating encoding a structured light pattern or a combination of a switchable SBG deflector for deflecting said light out said waveguide and a patterned mask applied to a surface of said waveguide for spatially modulating said light, wherein said first grating configuration is a passive SBG for deflecting said light out of said waveguide as uniform illumination.
- 5
10. The apparatus of claim 8 further comprising an input coupler grating or an input coupler prism for admitting said light into said waveguide.
- 10 11. The apparatus of claim 8 wherein said first and second grating configurations are disposed in upper and lower waveguide layers respectively, wherein said first grating configuration comprises, disposed in said upper waveguide substrate, a switchable input grating coupler in its diffracting state and a switchable output grating coupler in its diffracting state, wherein said switchable input grating coupler in its diffracting states couples said light into said upper waveguide substrate and said switchable output grating coupler in its diffracting state deflects uniform illumination out of said upper waveguide substrate, wherein said lower waveguide substrate admits through the reflecting surfaces of said upper waveguide substrate when said upper waveguide substrate input grating coupler and output grating coupler are in their non-diffracting states.
- 15

20

12. The apparatus of claim 11 wherein second grating configuration comprises disposed in a lower waveguide substrate a passive input grating coupler and a passive grating encoding a structure light pattern for deflecting structured illumination out of said lower waveguide substrate.

5

13. The apparatus of claim 11 wherein second grating configuration comprises disposed in a lower waveguide substrate a passive input grating coupler, a passive grating deflector and a patterned mask for deflecting structured illumination out of said lower waveguide substrate.

10 14. The apparatus of claim 11 wherein second grating configuration comprises disposed in a lower waveguide substrate a passive input grating coupler and a passive structure of alternating passive grating regions and mirror regions for deflecting structured illumination out of said lower waveguide substrate.

15 15. The apparatus of claim 11 wherein second grating configuration comprises disposed in a lower waveguide substrate a passive input grating coupler and a passive grating deflector and a patterned mask, a mirror and quarter wave plate configured for deflecting structured illumination of S and P polarizations out of said lower waveguide substrate.

20

16. The apparatus of claim 1 wherein said switchable grating is one of a switchable Bragg grating, a switchable grating recorded in a holographic polymer dispersed liquid crystal material, or a switchable grating recorded in a reverse mode holographic polymer dispersed liquid crystal, and said passive grating is one of a surface relief grating, a Bragg grating, a grating recorded in a holographic polymer dispersed liquid crystal material or a patterned mask.
- 5
17. The apparatus of claim 1 wherein at least one of said uniform or structure illuminations is shaped by one of a refractive, reflective or diffractive lens.
- 10
18. The apparatus of claim 1 wherein said time intervals at least partially overlap.
19. The apparatus of claim 1 wherein said light is provided by a laser or a LED.
- 15 20. The apparatus of claim 1 providing overlapping uniform and structured illumination beams.

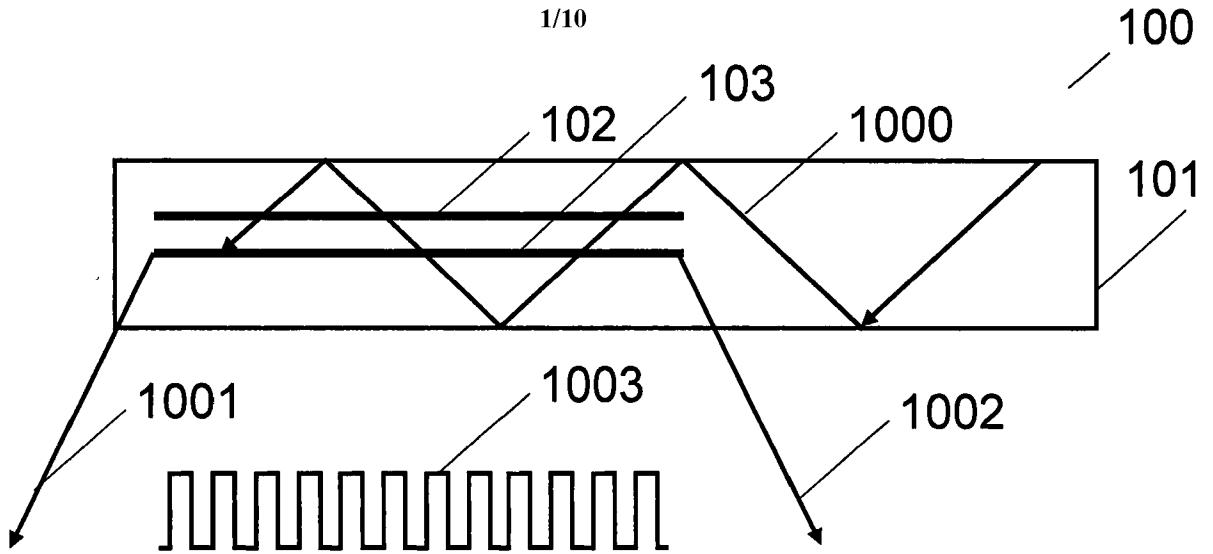

FIG. 1

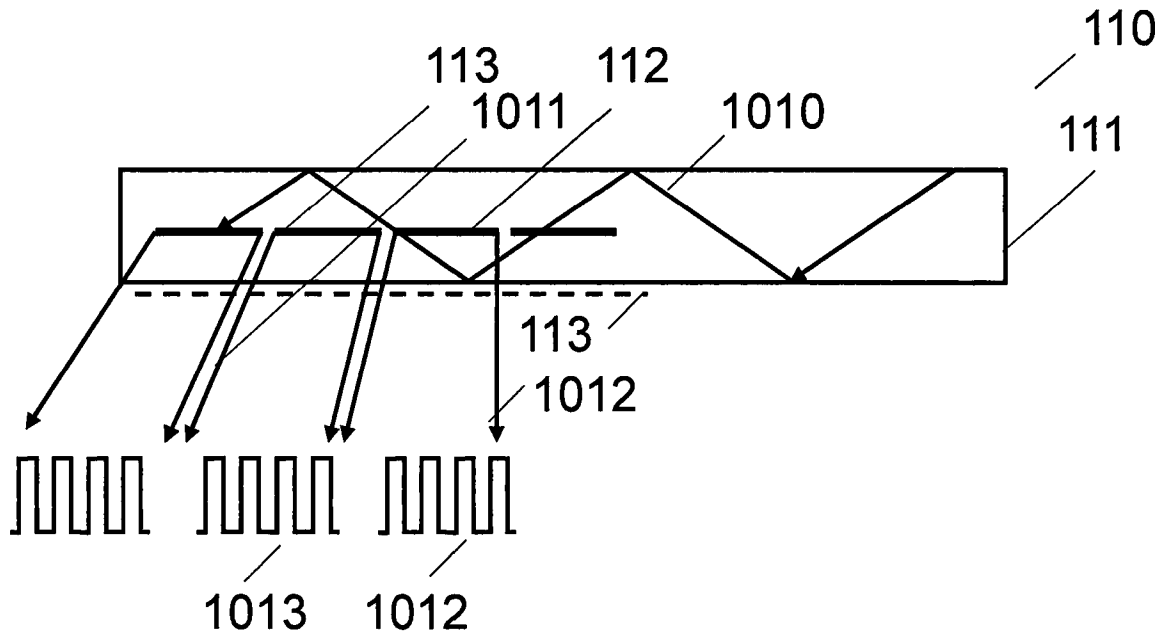

FIG. 2

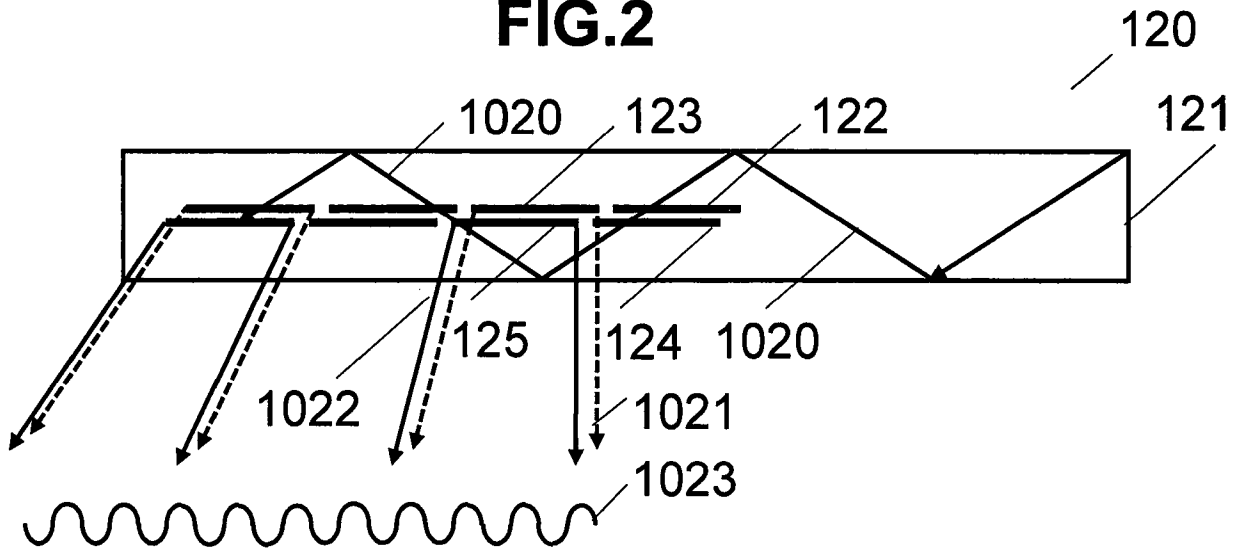

FIG. 3

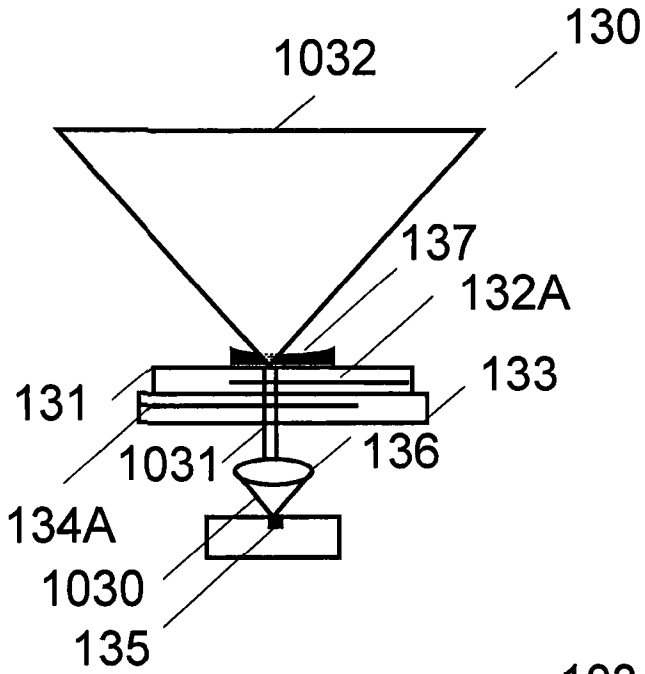

FIG. 4A

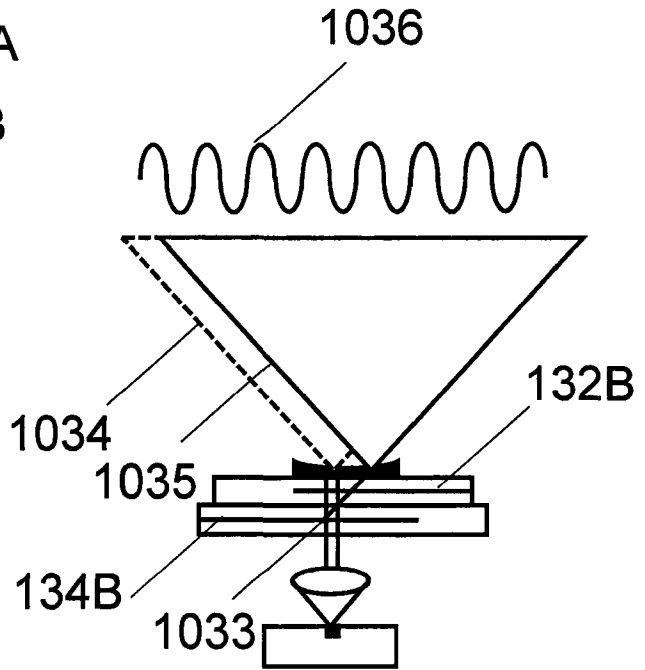

FIG. 4B

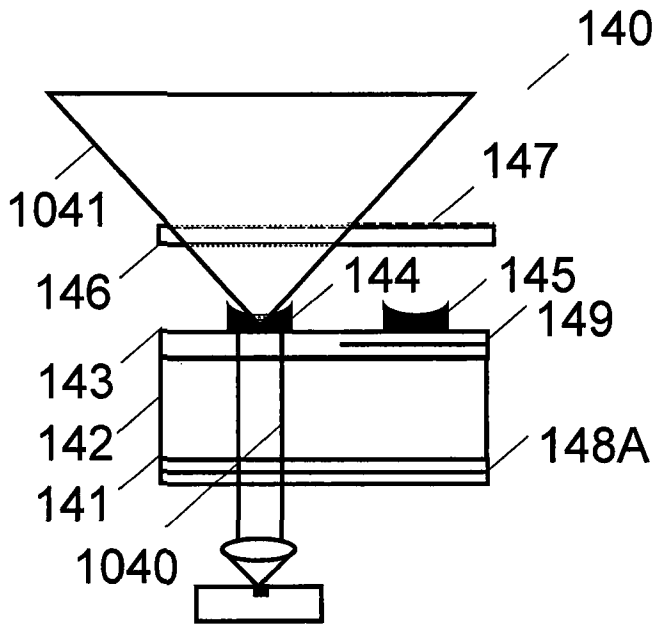

FIG. 5A

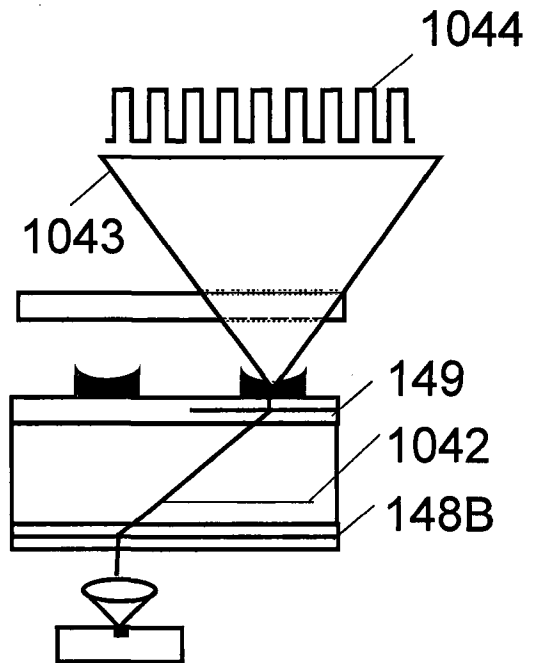

FIG. 5B

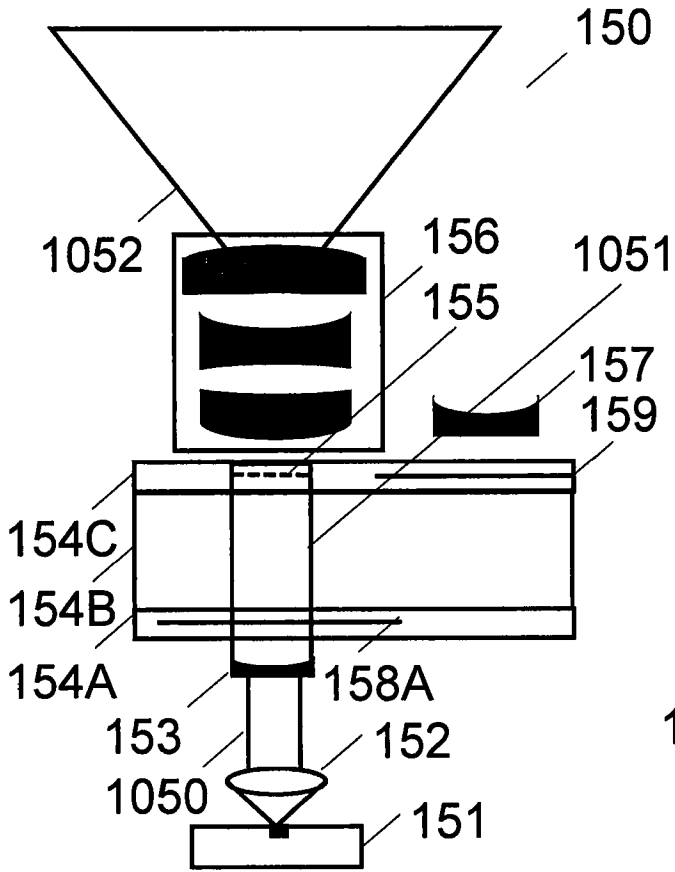

FIG. 6A

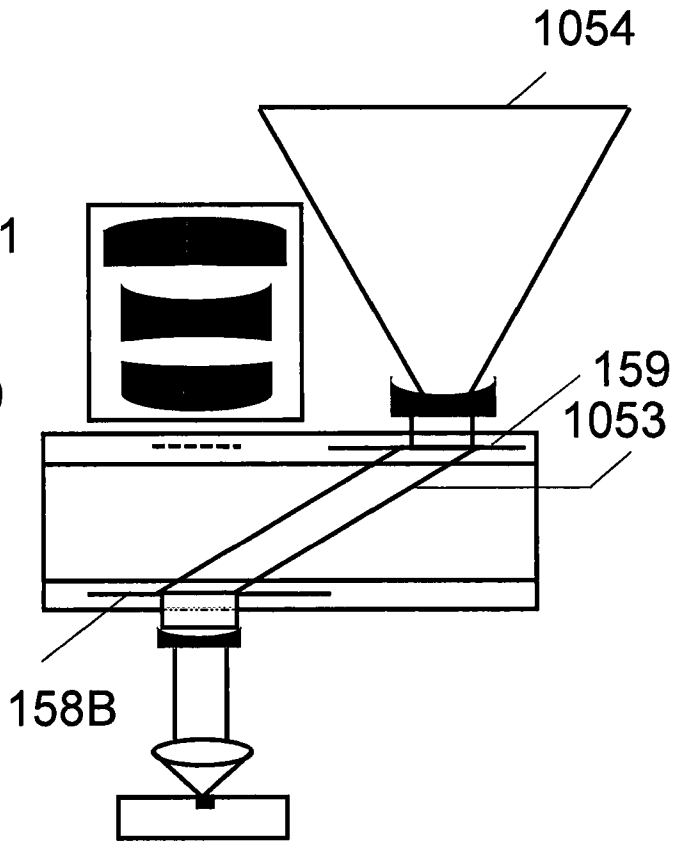

FIG. 6B

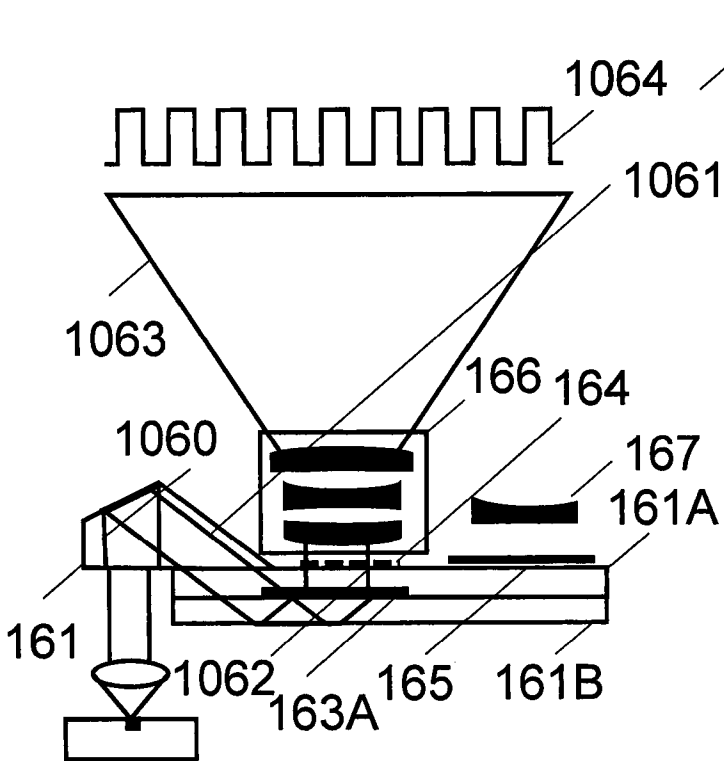

FIG. 7A

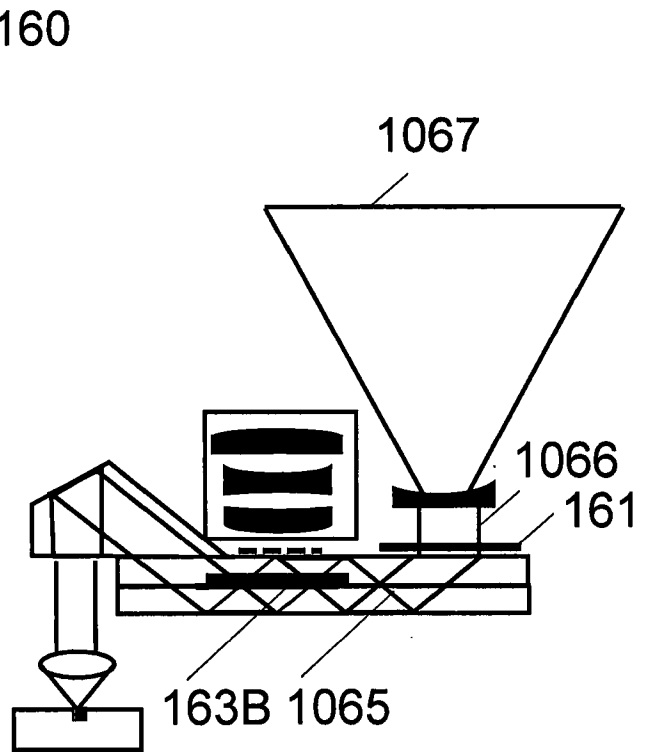

FIG. 7B

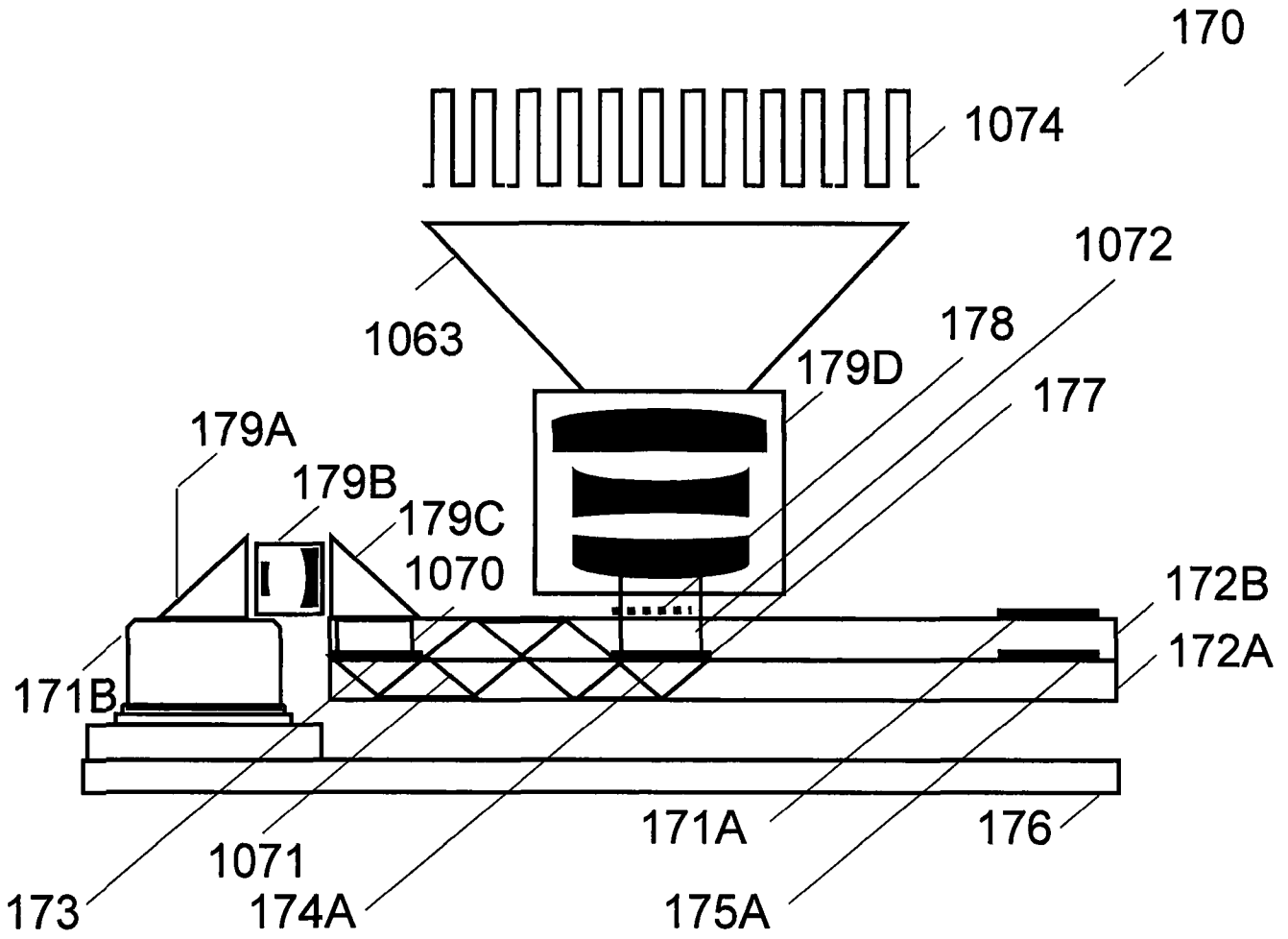

FIG. 8A

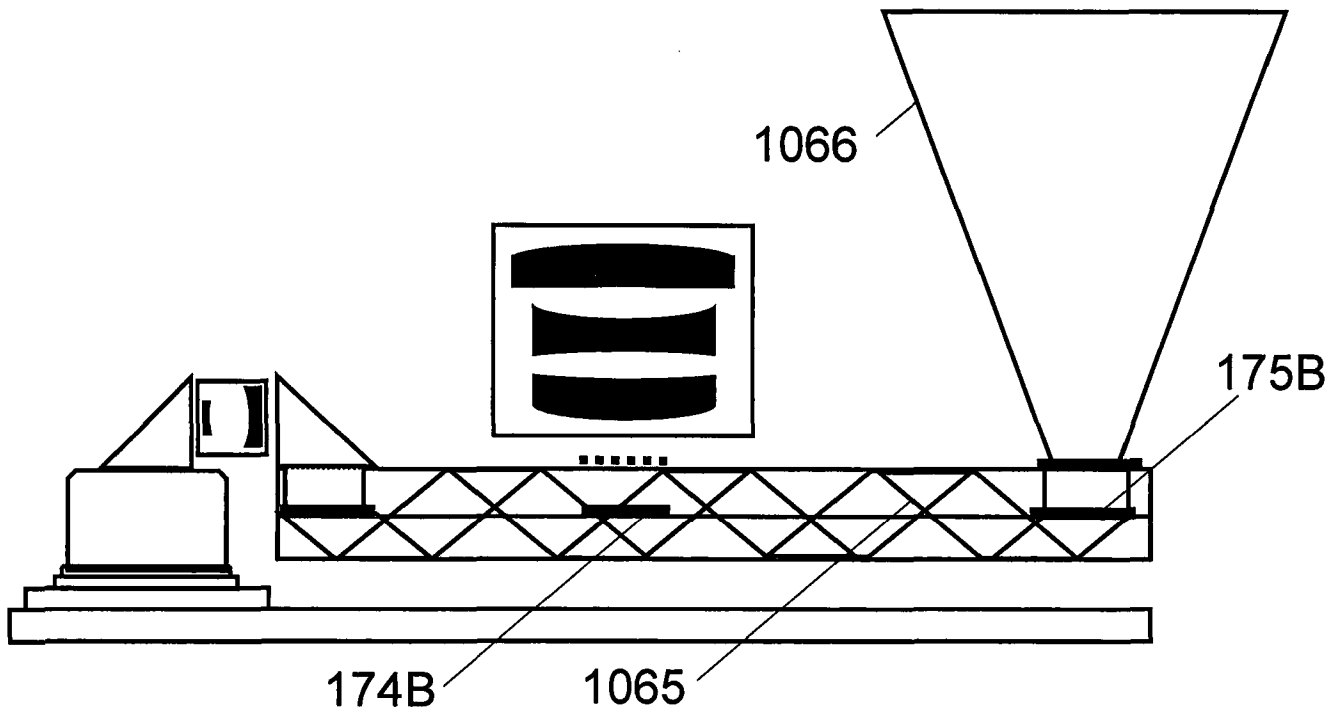

FIG. 8B

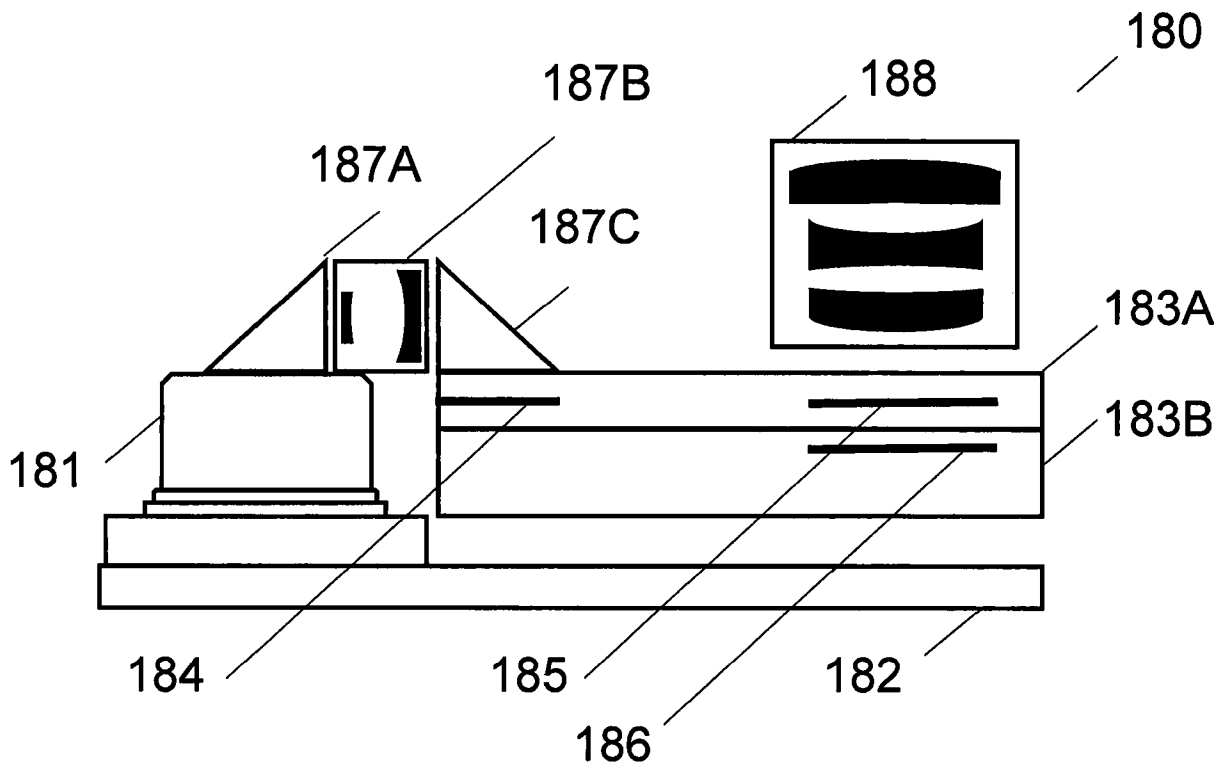

FIG. 9

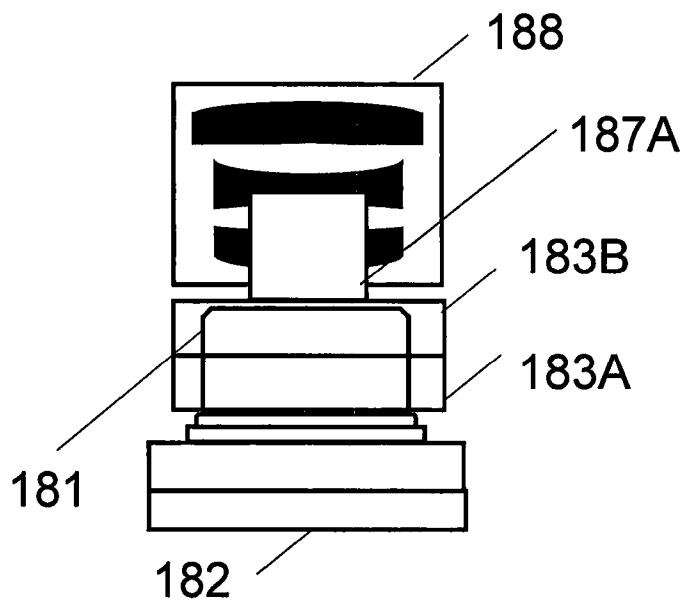

FIG. 10

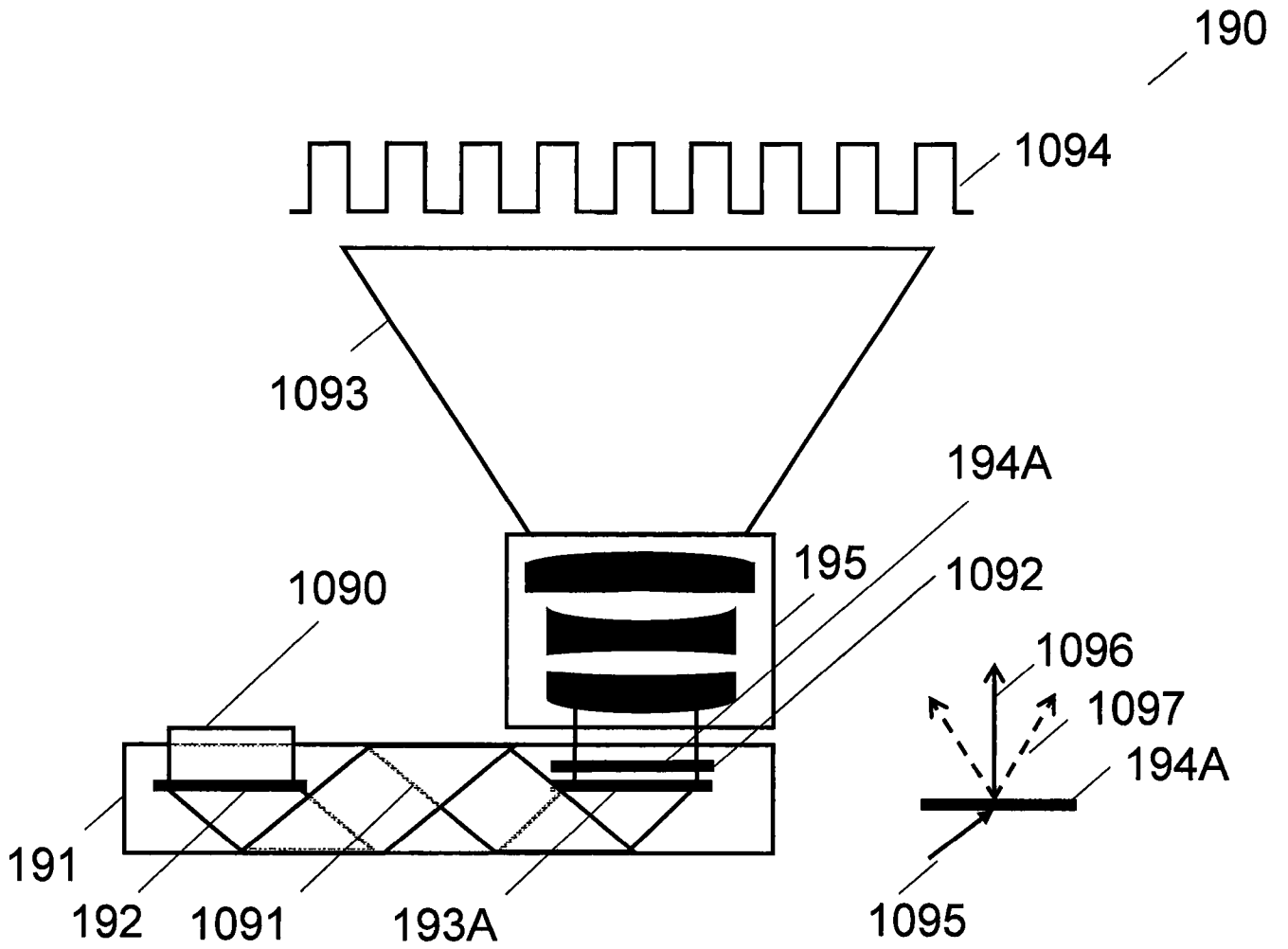

FIG.11A

FIG.11C

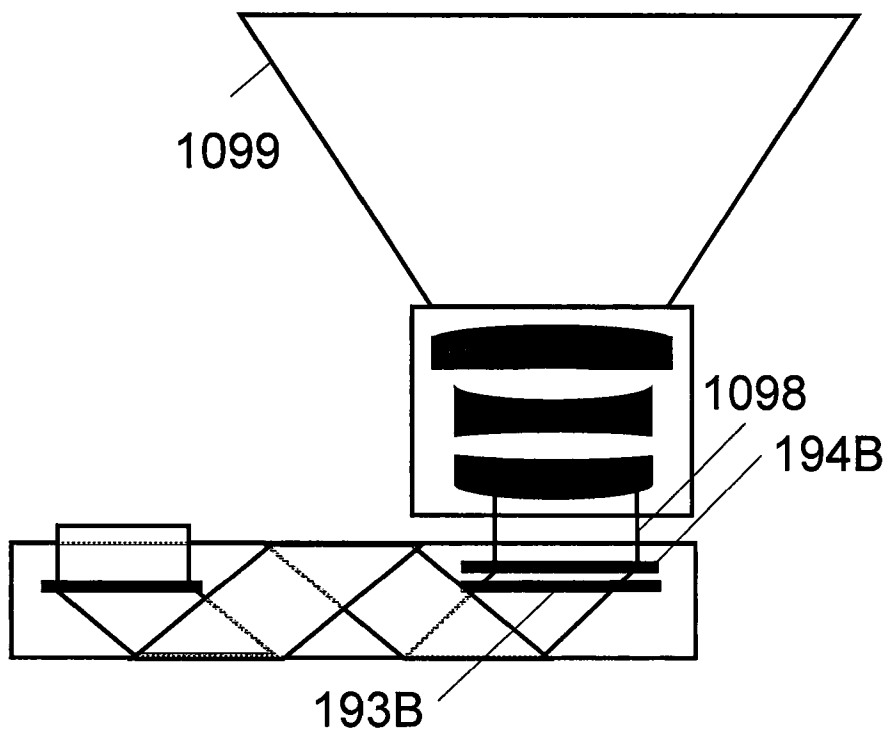

FIG.11B

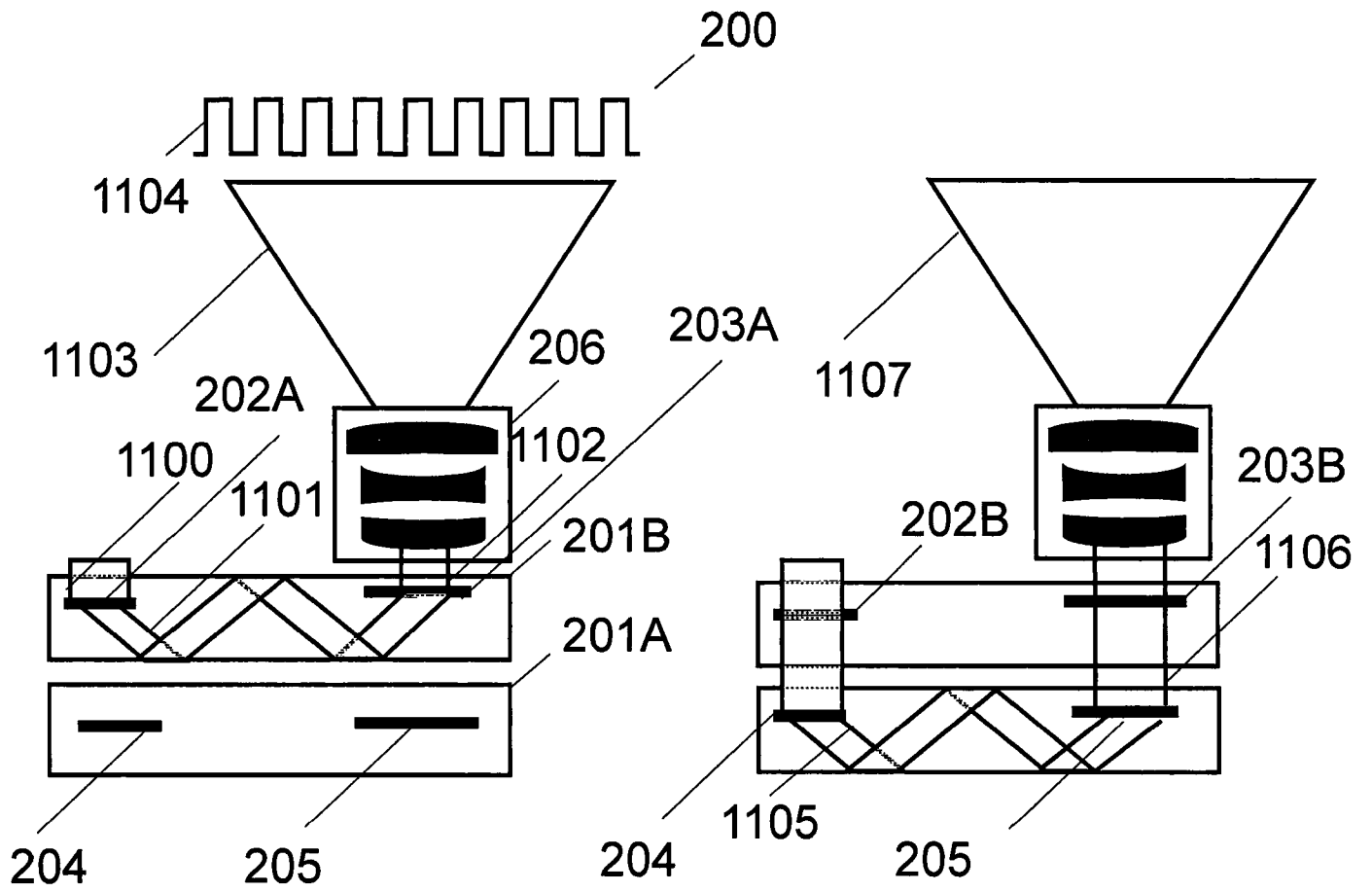

FIG.12A

FIG.12B

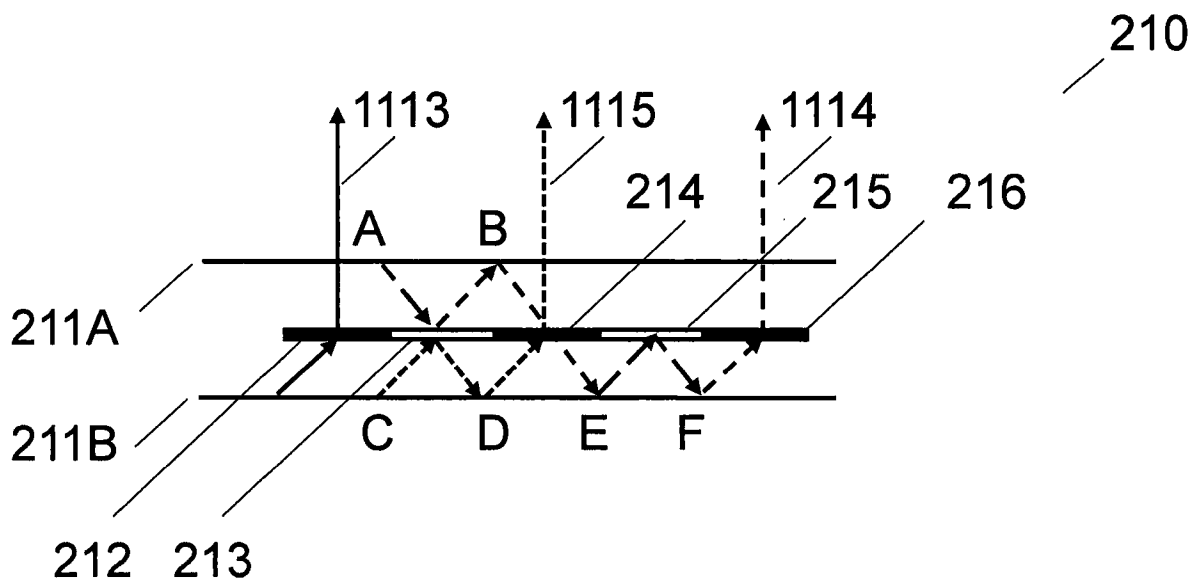

FIG.12C

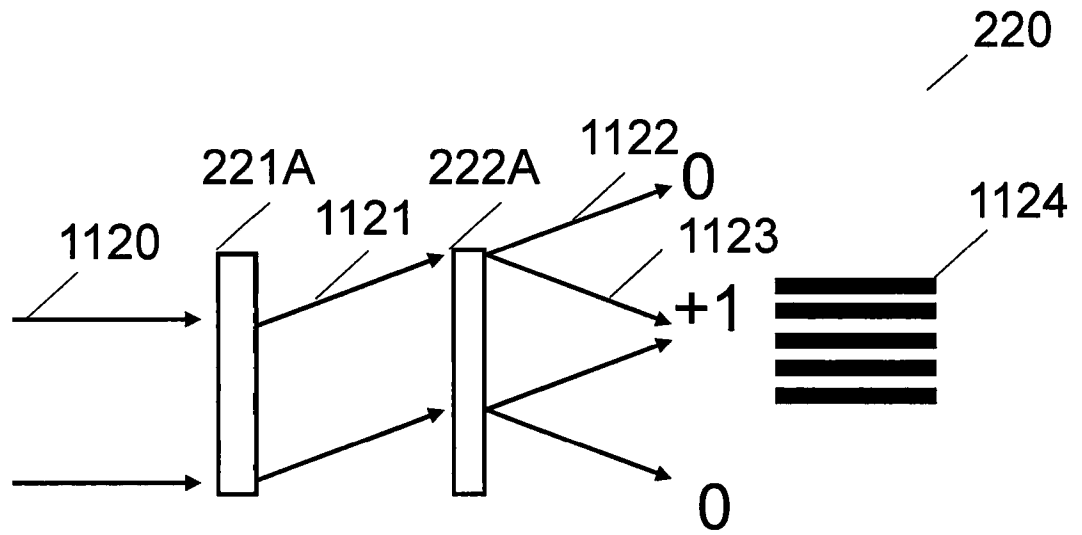

FIG.13A

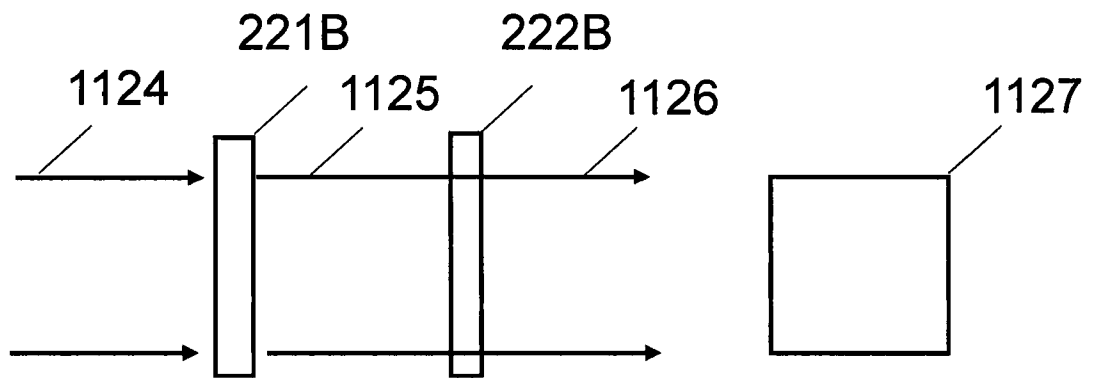

FIG.13B

230

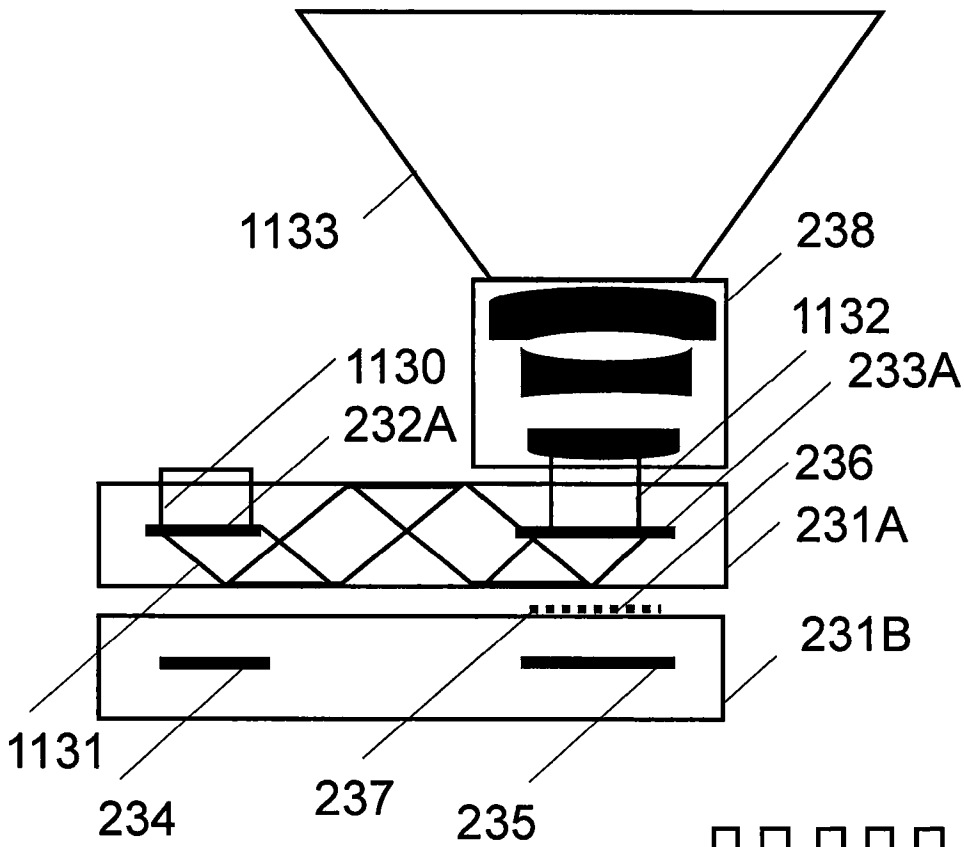

FIG.14A

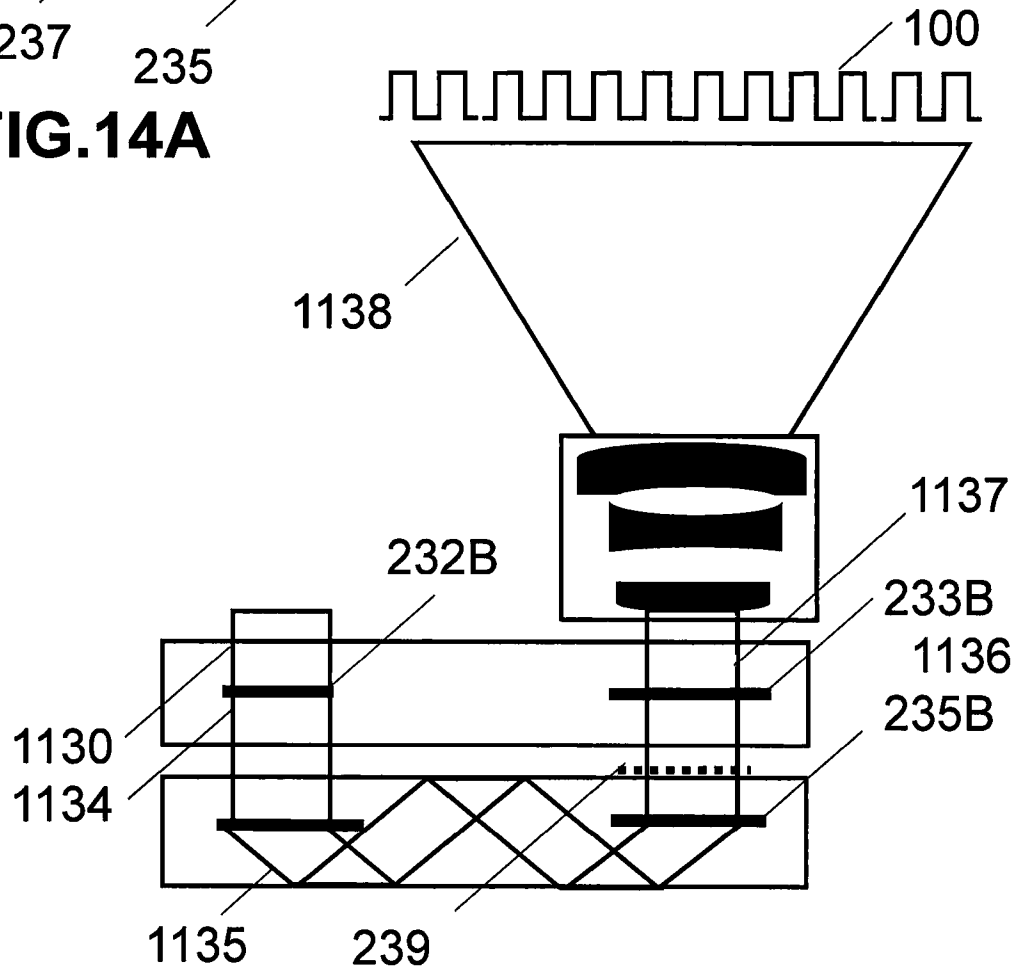

FIG.14B

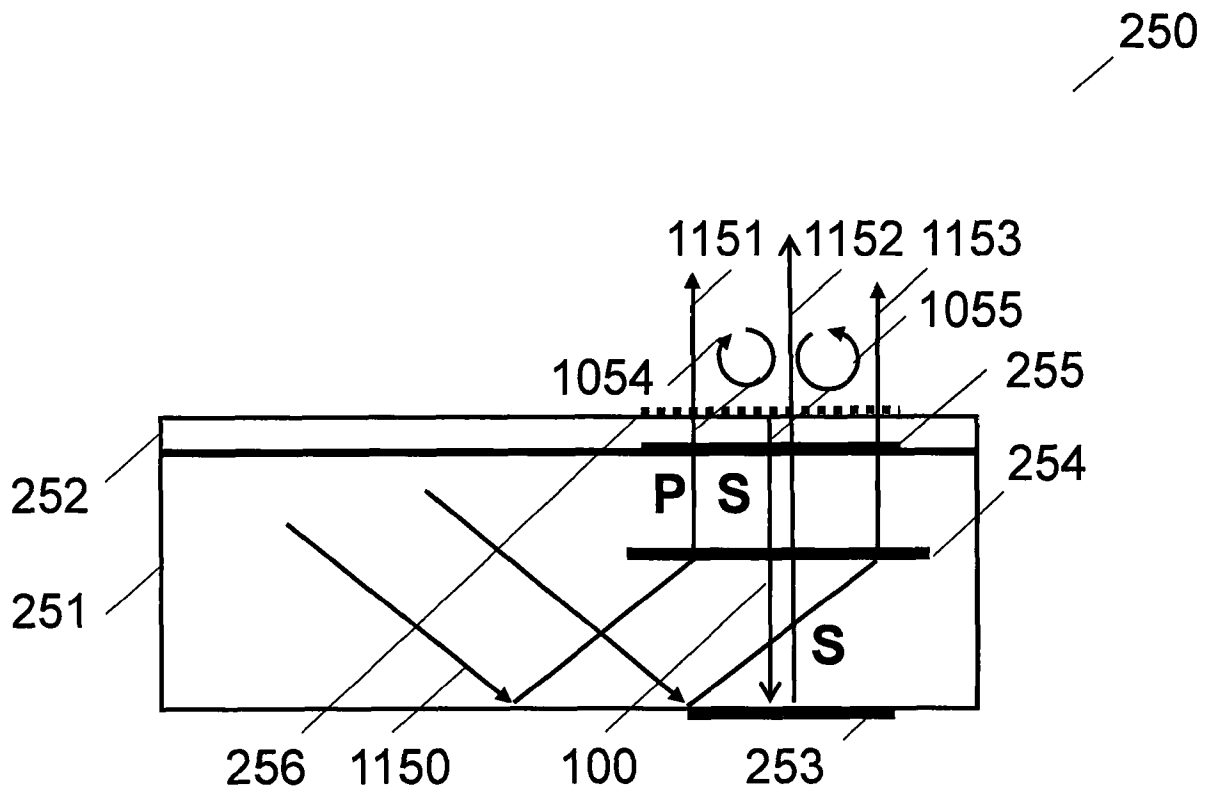

FIG.15

INTERNATIONAL SEARCH REPORT

International application No
PCT/GB2017/000055

A. CLASSIFICATION OF SUBJECT MATTER
INV. G02B26/08 G01B11/25 G02B27/09 G02B27/42 G02B27/01
ADD.
According to International Patent Classification (IPC) or to both national classification and IPC

B. FIELDS SEARCHED
Minimum documentation searched (classification system followed by classification symbols)
G02B G01B G01S G06T

Documentation searched other than minimum documentation to the extent that such documents are included in the fields searched

Electronic data base consulted during the international search (name of data base and, where practicable, search terms used)
EPO-Internal, WPI Data

C. DOCUMENTS CONSIDERED TO BE RELEVANT

Category*	Citation of document, with indication, where appropriate, of the relevant passages	Relevant to claim No.
X	WO 2011/042711 A2 (POPOVICH MILAN MOMCILO [GB]; WALDERN JONATHAN DAVID [US]) 14 April 2011 (2011-04-14)	1-3,8, 10,16-20
Y	abstract; figures 1,8,10-13 page 11, line 9 - line 23 page 17, line 3 - page 19, line 7	1-3,5-7, 9,18-20
X	US 2015/309264 A1 (ABOVITZ RONY [US] ET AL) 29 October 2015 (2015-10-29)	1-4,8, 10-16, 18-20
Y	paragraphs [0011] - [0013], [0114] - [0122], [0140] - [0143], [0148] - [0150], [0159] - [0169], [0182], [0195]; figures 3,5,7,8 paragraphs [0222] - [0225], [0232], [0233], [0430] - [0434], [0448]	1-3,5-7, 9,18-20
	----- -/--	

Further documents are listed in the continuation of Box C. See patent family annex.

* Special categories of cited documents :

"A" document defining the general state of the art which is not considered to be of particular relevance

"E" earlier application or patent but published on or after the international filing date

"L" document which may throw doubts on priority claim(s) or which is cited to establish the publication date of another citation or other special reason (as specified)

"O" document referring to an oral disclosure, use, exhibition or other means

"P" document published prior to the international filing date but later than the priority date claimed

"T" later document published after the international filing date or priority date and not in conflict with the application but cited to understand the principle or theory underlying the invention

"X" document of particular relevance; the claimed invention cannot be considered novel or cannot be considered to involve an inventive step when the document is taken alone

"Y" document of particular relevance; the claimed invention cannot be considered to involve an inventive step when the document is combined with one or more other such documents, such combination being obvious to a person skilled in the art

"&" document member of the same patent family

Date of the actual completion of the international search 19 July 2017	Date of mailing of the international search report 26/07/2017
---	--

Name and mailing address of the ISA/ European Patent Office, P.B. 5818 Patentlaan 2 NL - 2280 HV Rijswijk Tel. (+31-70) 340-2040, Fax: (+31-70) 340-3016	Authorized officer Blau, Gerd
--	--------------------------------------

INTERNATIONAL SEARCH REPORT

International application No
PCT/GB2017/000055

C(Continuation). DOCUMENTS CONSIDERED TO BE RELEVANT		
Category*	Citation of document, with indication, where appropriate, of the relevant passages	Relevant to claim No.
Y	DE 10 2013 209436 A1 (BOSCH GMBH ROBERT [DE]) 27 November 2014 (2014-11-27) abstract; figures 1-4 paragraphs [0004] - [0013], [0030] - [0039], [0050] -----	1-3,5-7, 9,18-20
Y	US 2013/016362 A1 (GONG YU [US] ET AL) 17 January 2013 (2013-01-17) abstract; figures 2,3 paragraphs [0002] - [0006], [0010], [0019] - [0020], [0023], [0027], [0028]; claims 1,2 -----	1-3, 18-20

INTERNATIONAL SEARCH REPORT

Information on patent family members

International application No PCT/GB2017/000055

Patent document cited in search report	Publication date	Patent family member(s)	Publication date
WO 2011042711 A2	14-04-2011	NONE	
US 2015309264 A1	29-10-2015	US 2015309264 A1	29-10-2015
		WO 2015006784 A2	15-01-2015
DE 102013209436 A1	27-11-2014	NONE	
US 2013016362 A1	17-01-2013	CN 103649677 A	19-03-2014
		DE 112012002943 T5	30-04-2014
		GB 2507020 A	16-04-2014
		JP 2014522981 A	08-09-2014
		US 2013016362 A1	17-01-2013
		WO 2013009676 A1	17-01-2013