

J. W. WHITE.  
AUTOMATIC CIRCUIT CLOSER.

No. 523,701.

Patented July 31, 1894.

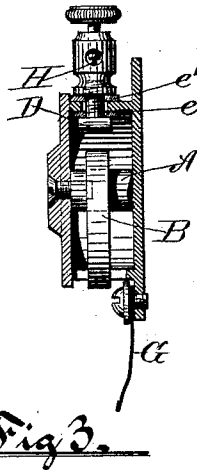
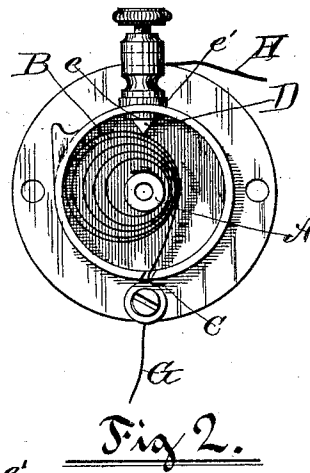
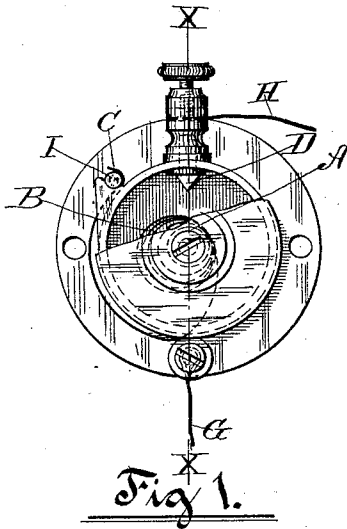

Witnesses

Inventor.

Theodore B. White

Joel White

Bertie L. Smith

J. W. WHITE.  
AUTOMATIC CIRCUIT CLOSER.

No. 523,701.

Patented July 31, 1894.

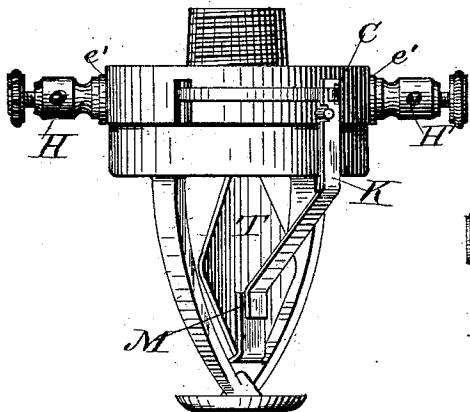

Fig 4.

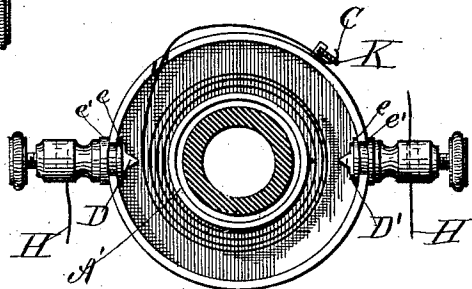

Fig 5.

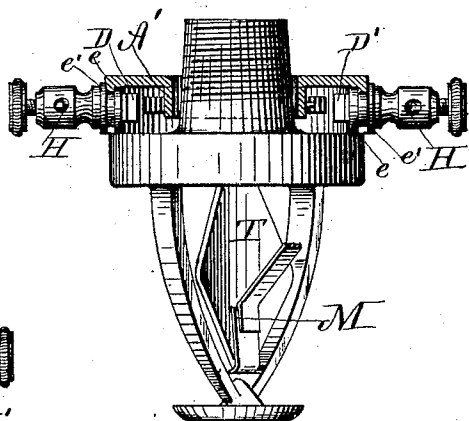

Fig 7.

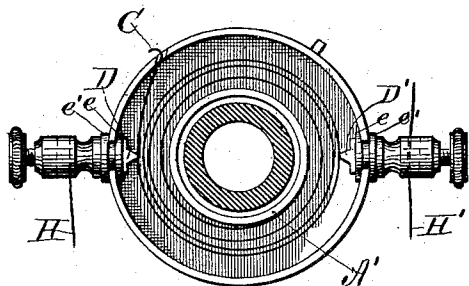

Fig 6.

Witnesses.

Theodore B. White

Berta E. Smith

Inventor

J. W. White

# UNITED STATES PATENT OFFICE.

JOEL W. WHITE, OF PROVIDENCE, RHODE ISLAND, ASSIGNOR OF ONE-HALF  
TO ASHBEL T. WALL AND GEORGE A. WALL.

## AUTOMATIC CIRCUIT-CLOSER.

SPECIFICATION forming part of Letters Patent No. 523,701, dated July 31, 1894.

Application filed March 11, 1893. Serial No. 465,627. (No model.)

*To all whom it may concern:*

Be it known that I, JOEL W. WHITE, a citizen of the United States, residing at Providence, in the county of Providence and State of Rhode Island, have invented a new and useful Automatic Circuit-Closer, of which the following is a specification.

My invention relates to improvements in circuit-closers which act automatically on a certain high temperature being reached, or upon the motion of some part of another apparatus to which it is attached, and the object of my invention is to provide an automatic circuit-closer, at once inexpensive in construction and positive and certain in action. I attain this object by the mechanism illustrated in the accompanying drawings, in which—

Figure 1 represents a front view of a simple form of the apparatus with a portion of the cover removed, and the circuit-closer ready for action. Fig. 2 is a similar view with the whole of the cover removed, and representing the circuit closed by action of the apparatus. Fig. 3 is a transverse section taken substantially along the line  $xx$  of Fig. 1. Fig. 4 represents the apparatus applied as an attachment to the present form of the Grinnell automatic fire extinguisher, and arranged to automatically close two circuits at the same time. Fig. 5 is an inverted face view of the attachment shown in Fig. 4, with the apparatus set for action. Fig. 6 is the same as Fig. 5, except that the apparatus is shown as having acted and closed the circuits. Fig. 7 is the same as Fig. 4, except that a transverse section of the attachment is shown.

Similar letters refer to similar parts throughout the several views.

Attached to and coiled about the central post A is the spiral spring B with the movable end C. When this movable end is drawn out and the spring consequently contracted, as in Figs. 1, 4 and 5, the spring does not come in contact with the electrode D, which is insulated at  $e$  and  $e'$ . When, however, the end C is let go and the spring allowed to expand its coils, as in Figs. 2 and 6, it rubs against electrode D and closes a circuit between the ground or a line attached to the apparatus, as at G, and a line attached to the insulated

electrode D, as at H. If desired, the apparatus may close two circuits to the ground or corresponding line, as in Fig. 6, at D and D'.

The apparatus may be used either on an open or a closed circuit, in the one case closing an open circuit, and in the other case grounding or short-circuiting a closed circuit.

The movable end of the spring may be held back by a drop of solder, fusible at a certain temperature, by a fusible metal plug, as at I in Fig. 1, or by an arm K, as in Figs. 4 and 5.

The spring may be made of steel or of any other elastic metal, but preferably is of some not easily corroded metal like phosphor-bronze.

In Figs. 1, 2 and 3, the apparatus is arranged for use as a thermostat or automatic fire-alarm. Whenever a temperature is reached which will soften the solder or fusible plug I, the end C is freed, the spring B expands and rubs firmly against the electrode D, closing a circuit between A and D, and giving an alarm by any of the well known devices operated by the closing of an electric circuit.

In Figs. 4, 5, 6 and 7, the apparatus is arranged for use as an attachment to the Grinnell automatic fire extinguisher. The movable end of the spring C is caught on the arm K, which is soldered at M to the strut T of the automatic fire-extinguisher. On the solder M softening by heat, or the strut T springing by the fire-extinguisher starting into action, the end C is freed, the coils of the spring B expand and rub firmly against the electrode D, or, if a double set of alarms are desired, against the electrodes D and D', completing the circuit between the body of the apparatus and the lines H and H' attached to the points D and D', and thus grounding these lines, since the body of the apparatus is attached to the water-pipes and thus connected with the ground. In this form the central pin A is replaced by the hollow collar A'. In practice I deem it preferable, in this form of the apparatus, to connect D with an annunciator within the building, and D', if desired, with a closed circuit connecting at a central office with a galvanometer, relay, or similar apparatus for indicating that such closed circuit has been short-circuited or grounded.

It is possible with this apparatus to close more than two circuits; but I do not think that more than three can be closed with the absolute certainty that there is when the apparatus operates a smaller number. The apparatus may be used with other automatic fire-extinguishers or for other similar uses, wherever it is necessary to automatically close, ground, or short-circuit an electric current.

It will now be plain that my invention is the combination of a coiled spring, with means for holding it under tension when coiled, and an electrode or a plurality of electrodes, against which the spring strikes and also rubs when released; thereby effectually closing the circuit.

I am aware that bent tubes filled with fluid have been used as the moving electrode of a thermostat, for example as shown in patents to Prentiss, No. 313,523, dated March 10, 1885, and Stone, No. 351,719, dated October 26, 1886, and I disclaim all shown in those patents, for in my invention the moving electrode is a spring under tension and must therefore be held at both ends, and be released by releas-

ing one end, when the spring flies out striking a blow against the stationary electrode, and then moves lengthwise scraping and rubbing over the stationary electrode, insuring an excellent electrical contact in spite of dust, or scale, on the two surfaces.

What I do claim as my invention, and desire to secure by Letters Patent, is—

1. In an automatic circuit-closer the combination of a spring constituting one electrode and inner and outer supports for that spring when under tension; with a second electrode out of contact with the spring when under tension, but limiting the sidewise motion and permitting the endwise motion of the spring when released; all substantially as described.

2. In combination a case; a coiled spring; its inner support within and near the middle of the case; its outer support outside of the case; and an electrode insulated from and within the case; all substantially as described.

JOEL W. WHITE.

Witnesses:

THEODORE B. WHITE,  
BERTIE E. SMITH.