

(19)



Europäisches Patentamt

European Patent Office

Office européen des brevets



(11)

EP 0 726 799 B1

(12)

EUROPEAN PATENT SPECIFICATION

(45) Date of publication and mention
of the grant of the patent:

01.09.1999 Bulletin 1999/35

(21) Application number: **94928909.4**

(22) Date of filing: **11.10.1994**

(51) Int. Cl.⁶: **A63H 33/12**

(86) International application number:
PCT/FI94/00457

(87) International publication number:
WO 95/10341 (20.04.1995 Gazette 1995/17)

(54) CONSTRUCTION KIT AND ITS ELEMENTS

KONSTRUKTIONSBAUSATZ SOWIE SEINE ELEMENTE

SYSTEME DE CONSTRUCTION ET SES ELEMENTS

(84) Designated Contracting States:
AT BE DE DK FR GB IE IT NL SE

(30) Priority: **11.10.1993 FI 934489**

(43) Date of publication of application:
21.08.1996 Bulletin 1996/34

(73) Proprietor:
Enqvist, Johan, Reinhold
FIN-02700 Grankulla (FI)

(72) Inventor:
Enqvist, Johan, Reinhold
FIN-02700 Grankulla (FI)

(74) Representative:
Hjelt, Dag Silvio Hjalmar Andrea
Borenius & Co Oy Ab,
Folkskolegränd 3
00100 Helsingfors (FI)

(56) References cited:
DE-A- 2 119 582 **GB-A- 1 378 803**
GB-A- 2 195 907

EP 0 726 799 B1

Note: Within nine months from the publication of the mention of the grant of the European patent, any person may give notice to the European Patent Office of opposition to the European patent granted. Notice of opposition shall be filed in a written reasoned statement. It shall not be deemed to have been filed until the opposition fee has been paid. (Art. 99(1) European Patent Convention).

Description

[0001] The invention relates to elements for a structural kit as defined in the preamble of the appended claim 1.

[0002] The prior art includes element based structural kits for the construction of various kinds of buildings. Such building element kits are usually rather complicated, since they are normally intended for full scale buildings for which stringent constructional and aesthetic demands are set.

[0003] The prior art also includes playhouses of element construction wherein certain elements may be interconnected into a building of predetermined form without any essential possibility for alternating the general structure. Essentially the actual structural work is performed once and the end result will always be the same. Thus, there is no possibility e.g. for children freely to apply their fantasy in order to obtain an "architecture" according to their own wishes. Such playhouses cannot either at a later stage be rebuilt or altered in accordance with changing playing needs or for example increased material resources.

[0004] Further, structural play kits are known for the construction of various playing structures. Among others such kits are known under trade names as "Meccano", "Lego" and the like, and they are mostly intended for constructing on a very small scale where, on the other hand, the mechanical strength is unimportant.

[0005] Publication DE-A-2 199 582 shows a structural play kit comprising board elements and interconnecting means therefore. Said elements have holes arranged at their edges. The outermost holes located at each element corner are at equal distances from both the adjacent perpendicular edges, which arrangement does not allow a structurally stable three dimensional corner structure to be assembled using the interconnecting means disclosed.

[0006] The present invention is intended to provide elements for a simple construction kit, for the construction of buildings mainly of a temporary nature and intended for playing purposes. The general dimensioning of said buildings is adapted for children's playing needs so that the spaces formed by the interconnected elements will be essentially smaller than normal buildings but still big enough so that children can dwell in said spaces. The structure must also be so stable that it without collapsing, can withstand the weight of several children simultaneously staying on top of said structure.

[0007] The object is further to provide a system combining high-grade simplicity with durability, stability, possibility to adaptation to a child's individual needs and a possibility to continuously expand the system in accordance with the individual ambitions of children and their parents. The system should further provide for a simple reconstruction of previously combined structures.

[0008] The elements for a construction kit according to the invention are characterized by the disclosure in

the characterizing part of claim 1.

[0009] Hereafter the invention will be more closely described with reference to the appended drawings, wherein

5

Fig 1 is a perspective view of an erected basic module according to one embodiment of the invention,

10

Fig 2 shows examples of different details for the promotion of playing and fantasy training,

Fig 3 including partial figures 3a...3d show examples of different board like basic elements according to the invention,

15

Fig 4 shows a more complicated structure composed of several basic modules in accordance with the invention,

Fig 5 shows a structure set up in an alternative manner and having functions for a toy shop as well as a normal child's bed,

20

Fig 6 shows a further example of a composed structure of still greater complexity,

Fig 7 shows how adjacent board like basic elements are interconnected according to one embodiment of the invention,

25

Fig 8 shows in section an interconnection according to Fig 7,

Fig 9 in a corresponding manner shows how elements are interconnected at right angles to each other, using an oblong bar according to one embodiment of the invention,

30

Fig 10 in section shows the connection according to claim 9,

35

Fig 11 in section shows how elements are interconnected at an angle in accordance with an alternative embodiment of the invention,

Fig 12 in section shows a further alternative connection, and

Fig 13 in principle shows how elements are interconnected to constitute an inner corner.

40

[0010] According to Figures 1 and 4 a basic module according to one embodiment of the invention is erected partly of modular board like square basic element 1, 12 and, at suitable locations, alternatively of rectangular basic elements 11, respectively, and partly of elements comprising special details 4 or detail portions 2, 3 essentially obtained by omitting certain elements. At least some of the board like elements 1, 11, 12, 13 are structurally load bearing elements taking, in themselves, up those loads which might be caused by the dead weight of the structure and by the use for playing purposes.

45

[0011] In the embodiment according to Figure 1 said special details comprise an opening 2 adjacent to the ground, said opening being intended for use as a door into the basic module, as well as an opening 3 adjacent to the ceiling and/or wall surface of said basic module and being intended for use as a window during playing,

55

an alternative window being constituted by using a special element having a circular opening 4. Figure 2 discloses a number of elements 13 showing other examples of such details. Said details may comprise, for example, different kinds of closed openings 4, openings 5 open to one side, door elements 6, or e.g. a special text 7, a special coloring or other such special details promoting the fantasy education of children. In addition to such details which are included as parts of modular elements in accordance with the invention the system may comprise e.g. special triangular gable elements (not especially shown in the Figures) or elements standing completely by themselves but being connectable to some element, for which a flag pole 8 in Figure 6 may be used as an example.

[0012] Figures 4 to 6 disclose further examples of more complicated three dimensional room structures for use in play, where the structure according to Figure 5 simultaneously comprises normal functional solutions, in this case a portion 9 intended for use as a normal bed, at which the lower levels of the structure simultaneously may be used as steps. Alternatively, the structural kit may comprise, as a special detail, special ladder elements or elements having an integral ladder structure. In all cases disclosed in the Figures the basic modules comprise at least one opening 2 intended for use as a door, but e.g. an embodiment structured for use as, for instance, a "pirate ship" may instead of a door comprise such basic modules which are accessible only from the top, and which represent "cargo holds", "prison dungeons" or the like spaces which may be utilized during playing.

[0013] In principle the structure of the three dimensional basic module is a cube having square modular sides. Said sides are primarily constituted of board like basic elements 1, 11, 12 based on a basic modular standard side measure "b" and manufactured from a suitable board material, e.g. plywood, sheet metal, plastic boards or the like. Said board like elements are as such dimensioned to take all such loads which a normal use of the structure may cause, and the structure can thus be erected without any further load bearing framework.

[0014] In practice the respective board like basic elements comprise four modular sides 10, as is evident from Figure 3, and each basic element has a defined board thickness "a" (see Figure 13). In a favorable embodiment every modular side 10 has a modular width "b" of e.g. 30...120 centimeters, suitably 60, 80 or 100 centimeters, while said thickness "a" is of an order of 1 to 20 millimeters; for a material based on wood fibres it is suitably 4 to 12 millimeters; for outdoor use perhaps slightly more, e.g. 15 to 16 millimeters. According to one embodiment said elements may comprise a load bearing connective edge (see for example 16' in Figure 12) surrounding boards made of a material which is essentially thinner, for instance of an order of 0.5 to 6 millimeters. In certain cases said connecting edge 16' is

suitably glued to said boards at at least one edge, while said edge in other cases may be more or less detachable in order to permit freer rebuilding possibilities.

[0015] As basis for a structure according to the invention one may also use a smaller basic element, for example one having a side width of 30 to 60 centimeters, in which case larger elements have sides of a width which is a multiple of the side width of said smaller element. Such smaller elements may also be interconnected at an angle, or alternatively they may have their edges directed one towards the other for constituting larger partial elements. Such smaller elements may also be used in combination with larger basic elements, as is evident from Figure 6 at the reference 20.

[0016] Each basic element 1, 11, 12 is designed so that it may be connected to another corresponding element. For this purpose each respective basic element, i.e. at least said larger rectangular elements 1 and any possible additional elements 11, 12, comprises series of holes 18 (see Figure 3) into which interconnecting tightening elements, e.g. bolts 14 or the like, may be inserted in accordance with Figures 7 to 12. Corresponding holes are also arranged at at least one side edge or the like in elements 13 having said special details, and at any other possible extra elements 8.

[0017] Said tightening elements 14 are used for the attachment of interconnecting elements 15, 16, 16' to said board like basic elements 1 and said extra elements 11, respectively, in which case said elements 14, 15, 16, 16' interact in order to connect selected board like elements either in a side-by-side relationship (see Figures 7, 8) or edge-to-edge at an angle (see figures 9 to 12). Since said element boards normally, as such, carry any such loads which the use might cause, the main function of said connecting elements 14, 15, 16, 16' will only be to interconnect the different board like elements 1, 11, 12, 13 into a desired three dimensional form. In certain especially heavily loaded cases said interconnecting elements, or special reinforcing elements may be used as enforcement especially against buckling.

[0018] Since the interconnection should be simple it is favorable that said bolts 14 or the like, as well as any related locking elements like nuts 14a or the like may be tightened using the same tool, for example a hexagon spanner, but also conventional screw heads 14' intended for a screw driver, or socket head caps or the like may be acceptable. In certain cases said nut element 14a or the like may be replaced by a screw threading 14b made directly into the respective interconnecting elements 15, 16, 16', or alternatively in the actual board material or in a special reinforcing edging suitably made of metal or a plastic material.

[0019] In principle said interconnecting elements 15, 16, 16' are so designed that each respective element 15, 16, 16' comprises at least two holes 17, 17a, suitably one at each respective end of a respective interconnecting element 15, 16, 16'. In the embodiments shown

in the drawings interconnecting elements of a straight design have been generally referred to as 15, while the reference 16, 16' generally indicates elements for connecting at an angle. Figure 7 shows a connection using interconnecting elements having a short dimensional size in the lateral direction. In Figure 9 the corresponding elements are in the form of an oblong rim, for example V-bars and/or flat iron, but said interconnecting elements 15 may of course also be of an oblong design, while said angle elements 16 may comprise for example console-like shorter elements. Figure 11 shows a connection where an interconnecting element 16 at at least one side has a leg 21 inserted into a groove in a corresponding board like element 1, and said Figure also shows an alternative interconnecting arrangement comprising a counter-sunk screw 14' and threading arranged in the angle bar 16 itself. These features may, of course, also be utilized in other combinations. Figure 12 shows an interconnection using rims having a special design with grooves 22 for receiving the edges 10 of said element boards 1, 11, 12, 13. For thicker board material said grooves are made correspondingly wider, and in certain cases one side of said groove may be completely removed so that said rim, in practice, actually corresponds to the angle bars discussed above. The arrangement mentioned above also facilitates the connection of boards of different thickness to the same rim. In certain embodiments one or several interconnecting rims 16, 16' may comprise further grooves, in addition to said actual grooves 22 intended for receiving the primary element boards 1, 11, 12, 13. Said further grooves may be essentially parallel with said actual grooves 22, so that further boards, for example signboards or the like arranged in a parallel manner, may be attached to the same rim. Said rims 16, 16' may also comprise further grooves extending in a different direction, so that also boards which are not parallel with said primary element boards, for example inclined roofing boards or the like additional elements, may be attached in a simple manner to the same rim 16, 16'.

[0020] According to one embodiment of the invention each attachment point (and respective combination of said holes 17, 18) arranged in double so that the tightening element 14 for said attachment point may be inserted into an alternative of two hole series or the like fastening positions arranged generally close to another. This will prevent said tightening elements 14 especially in an inner corner from being positioned one against the other, which in certain cases (e.g. when using bolts having nuts arranged in the inner portions of said corner) would lead to problems due to the lack of space. This arrangement is more closely disclosed in Figure 12, where the respective X and Y axes of said tightening elements do not cross, since the hole 17' having the axis Y' is out of use. According to a favorable embodiment the elements 16, 16' acting as angle bars are constituted of rims having a generally essentially proper rectangular cross section, and in this case mutually dis-

placed double holes 17, 17', 18 are indispensable, since only one respective bolt 14 or the like can be inserted in holes crossing each other in a common plane.

[0021] The interconnection is usually (except for the embodiment disclosed in Figure 12) performed edge-to-edge, either at right angle one to another (see Figures 9 to 12) or in a common plane (see Figures 7, 8). In this manner one can erect spatial structures of a nearly arbitrary design. Since the interconnection of the elements is extremely simple also small children, perhaps with some initial aid from an older person, can manage to build his or her own playing environments from said basic and additional elements 1, 11, 12 and utilizing elements 13 comprising special details 4, 5, 6, 7, and these environments may easily be altered and extended at a later stage.

[0022] For the connection two short interconnecting elements 15 are normally used (see Figure 7) or alternatively one longer element 16, 16' (see Figures 9, 12) extending over several holes 18 may be used. In certain special cases the number of interconnecting elements may be higher than two. At the interconnection said interconnecting elements 15, 16, 16' are provided with respective tightening elements 14. In certain cases said interconnection may be performed totally without any particular interconnecting elements so that a board like element 1 is tightened in between two other elements, for example an element 12 and special elements 13 in accordance with Figure 13. In certain special cases said interconnecting elements 15, 16, 16' are pre-attached in a more or less permanent manner to at least one side 10 of an element.

[0023] In order for the system to give a desired flexibility to the system it is favorable that at least each proper board element 1, 11, 12, 13 at at least one edge, suitably at several edges comprises holes 18 as discussed above, said holes preferably being arranged in a manner which is especially evident from Figure 3. The distance between said holes is selected so that to each proper board element 1, 11, 12, 13 an identical element is attachable, or an element one side of which has a modular size corresponding to, for instance, half said modular measure "b" of a proper board element 1, or to a multiple thereof. Thus, said holes 18 are suitably arranged at the outer edge 10 of each board element 1, 11, 12, 13, respectively, favorably at a mutually equal distance. In addition thereto at least the larger elements suitably comprise more centrally located holes 19 arranged at corresponding mutual distances from each other and from said holes 18 located at the edge, in which case said holes 19 in at least one direction are located in the inner portion of the surface area of the respective board element 1, 11. In this manner said board elements can be so attached that certain elements extend transversely from the centre of another element, as is evident from Figure 9. The exact position of said holes 18 in accordance with a favorable embodiment of the invention is more closely discussed in the

appended claims.

[0024] As evident from the drawings and from the above discussion, the disclosed embodiments comprise, besides quadratic basic elements 1 of a certain modular size, also elements of other forms and/or dimensions. Thus, the system may also be based on smaller elements 20, the side width of which correspond to half the side width of the larger elements discussed above. The system may further comprise other elements 11 of a rectangular form, or other quadratic elements 12 of another dimension than that of said basic elements. Generally such additional elements, though, are characterized in that they comprise at least one side the dimensions of which correspond to a multiple of half the modular standard width of said rectangular basic elements, in which case said side suitably is provided with said holes 18 arranged in accordance with the principles discussed above.

Claims

1. Elements for a structural kit for building, in a play like manner, three dimensional structures of play-house character, said elements comprising board like basic elements (1, 11, 12) made of an essentially three dimensional board material, said elements having a rectangular design, the dimensioning of which being based on a modular side measure (b), interconnecting elements (15, 16, 16') comprising pieces of a durable material provided with holes, as well as tightening elements (14, 14') fitting into said holes, said board like basic elements (1, 11, 12) and any possible additional elements (13, 20) comprising holes (18, 19) adapted for said tightening elements (14, 14') for connecting to said interconnecting elements (15, 16, 16'), for interconnecting said basic elements (1, 11, 12) and any possible additional elements (13, 20) to constitute a three dimensional building structure, the dimensioning of said elements and said additional elements (1, 11, 12, 13, 20) at at least one side corresponding to a multiple of said modular measure (b) and said holes (18, 19) for said interconnecting elements (14, 14') in each element, respectively, being located in a corresponding modular manner and opposite to corresponding holes (18, 19) in another element, said holes being, within the scope of a reasonable tolerance, located at such a distance (c) from a first adjacent outer edge (10) of said element which distance corresponds to half the distance between corresponding holes in the respective interconnecting element (15, 16, 16') **characterized** in that the outermost ones of respective holes (18) for said interconnecting elements (15, 16, 16') are located at such a distance (d) from a second adjacent outer edge (10) which joins said first adjacent outer edge which distance is greater than half the distance between corresponding holes in the respective interconnecting element (15, 16, 16'), by the width (e) of said respective interconnecting element (15, 16, 16').
2. Elements according to claim 1, **characterized** in that said elements (1, 11, 12, 13, 20) in addition to said holes (18) for said interconnecting elements (15, 16, 16') comprise further holes (19) for said interconnecting elements (15, 16, 16') which holes (19) are located at a substantially longer distance from at least one of said edges (10) of said element but on the same mutual modular internal distance (f).
3. Elements according to claim 1 or 2, **characterized** in that said elements (1, 11, 12, 13) at least at one edge (10) comprise reinforcement means which suitably simultaneously act as interconnecting elements for connecting to one or several adjacent elements (1, 11, 12, 13, 20).
4. Elements according to claim 3, **characterized** in that said reinforcement means comprise outer rims (16') located at the outer edge of said elements (1, 11, 12, 13, 20), said rims favorably having a planar and/or angular cross section and suitably being made of metal, hard plastic, wood or the like.
5. Elements according to claim 3, **characterized** in that said reinforcement means comprise pieces (21) which are recessed into a respective edge (10) of said elements, said pieces suitably at said holes (18) comprising threading (14b) or the like therein for said respective tightening element (14).
6. Elements according to any one of claims 1 to 5, **characterized** in that said elements (1, 11, 12, 13, 20) are dimensioned for carrying, in an essentially self-supporting manner, any loads which the normal use of an assembled building structure causes on said element (1, 11, 12, 13) when said structure is used as a play-house or the like.
7. Elements according to any one of claims 1 to 6, **characterized** in that said elements (1, 11, 12, 13, 20) comprise details and/or elements for promoting children's playing and/or fantasy education.
8. Elements according to claim 7, **characterized** in that said details comprise openings (4, 5, 6) intended to represent openings (2, 3) present in full scale buildings.
9. Elements according to claim 7, **characterized** in that said details are colors and/or specifically arranged markings (7) intended to represent functions present in the community.

10. Elements according to claim 7, **characterized** in that said details are structural additional features like door panels, roof hatches, ladders, flag poles (8) and the like.

Patentansprüche

1. Elemente eines Baukastens, mittels dessen in einer spielerischen Art und Weise dreidimensionale Bauten nach Art eines Spielhauses aufbaubar sind, die brettartige Grundelemente (1, 11, 12), die aus im wesentlichen dreidimensionalem Brettmaterial aufgebaut sind, eine rechteckige Form besitzen und deren Maße auf einer modularen Seitengröße (b) basieren, verbindende Elementen (15, 16, 16'), die Teile aus einem haltbaren, mit Löchern versehenen Material umfassen, sowie in diese Löcher passende Befestigungselemente (14, 14') umfassen, wobei die brettartigen Grundelemente (1, 11, 12) und alle möglichen zusätzlichen Elemente (13, 20) für die Befestigungselemente (14, 14') passende Löcher (18, 19) aufweisen zum Verbinden mit den verbindenden Elementen (15, 16, 16') und zum Verbinden der Grundelemente (1, 11, 12) mit allen möglichen zusätzlichen Elementen (13, 20), um eine dreidimensionale Gebäudestruktur zu errichten, wobei die Maße der Elemente und der zusätzlichen Elemente (1, 11, 12, 13, 20) an wenigstens einer der Seiten einem Mehrfachen der modularen Größe (b) entsprechen und die Löcher (18, 19) für die verbindenden Elemente (14, 14') in dem jeweiligen Element in einer entsprechenden modularen Art und den entsprechenden Löchern (18, 19) eines anderen Elements gegenüberliegend so angeordnet sind, daß die Löcher (18, 19), innerhalb einer vernünftigen Toleranz, sich in einer solchen Entfernung (c) von einem ersten benachbarten äußeren Rand (10) des Elements befinden, daß die Entfernung die Hälfte des Abstandes zwischen entsprechenden Löchern im entsprechenden verbindenden Element (15, 16, 16') beträgt, **dadurch gekennzeichnet**, daß die äußersten entsprechenden Löcher (18) für die verbindenden Elemente (15, 16, 16') in einer Entfernung (d) von einem zweiten benachbarten äußeren Rand (10), der an den ersten äußeren Rand grenzt, angeordnet sind, die um die Breite (e) des entsprechenden verbindenden Elements (15, 16, 16') größer als die Hälfte der Entfernung zwischen entsprechenden Löchern in dem entsprechenden verbindenden Element (15, 16, 16') ist.
2. Elemente nach Anspruch 1, **dadurch gekennzeichnet**, daß in den Elementen (1, 11, 12, 13, 20) zusätzlich zu den Löchern (18) für die verbindenden Elemente (15, 16, 16') weitere Löcher (19) für die verbindenden Elemente (15, 16, 16') vorhanden

sind, wobei die Löcher (19) sich in einem beträchtlich größerem Abstand von wenigstens einem der Ränder (10) des Elements befinden, aber in der gleichen gegenseitigen modularen internen Entfernung (f).

3. Elemente nach Anspruch 1 oder 2, **dadurch gekennzeichnet**, daß in den Elementen (1, 11, 12, 13) mindestens ein Rand (10) verstärkende Mittel umfaßt, die zweckmäßig gleichzeitig als verbindende Elemente zur Verbindung zu einem oder mehreren benachbarten Elementen (1, 11, 12, 3, 20) dienen.
4. Elemente nach Anspruch 3, **dadurch gekennzeichnet**, daß die verstärkenden Mittel äußere Kanten (16') umfassen, die sich an den äußeren Rändern der Elemente (1, 11, 12, 13, 20) befinden, vorzugsweise einen flachen und/oder eckigen Querschnitt aufweisen und zweckmäßig aus Metall, hartem Kunststoff, Holz oder dergleichen gemacht sind.
5. Elemente nach Anspruch 3, **dadurch gekennzeichnet**, daß die verstärkenden Mittel Teile (21) die in einen jeweiligem Rand (10) der Elemente eingelassen sind und zweckmäßig an den Löchern (18) Teile mit Gewinde (14b) oder dergleichen für das jeweilige Befestigungselement (14) umfassen.
6. Elemente nach einem der Ansprüche 1 bis 5, **dadurch gekennzeichnet**, daß die Elemente (1, 11, 112, 13, 20) so dimensioniert sind, daß sie Lasten, die durch den normalen Einsatz einer zusammengesetzten Gebäudestruktur auf das Element (1, 11, 12, 13) bei Gebrauch als Spielhaus oder dergleichen einwirken, in einer freitragenden Art aushalten.
7. Elemente nach einem der Ansprüche 1 bis 6, **dadurch gekennzeichnet**, daß die Elemente (1, 11, 12, 13, 20) Einzelheiten und/oder Elemente umfassen, die das Spielen und/oder die phantasiefördernde Erziehung von Kindern unterstützen.
8. Elemente nach Anspruch 7, **dadurch gekennzeichnet**, daß die Einzelheiten Öffnungen (4, 5, 6) umfassen, die Öffnungen (2, 3), die in lebensgroßen Gebäuden vorkommen, darstellen sollen.
9. Elemente nach Anspruch 7, **dadurch gekennzeichnet**, daß die Einzelheiten Farben und/oder speziell angeordnete Markierungen (7) sind, die Funktionen, die in der Gesellschaft vorkommen, darstellen sollen.
10. Elemente nach Anspruch 7, **dadurch gekennzeichnet**, daß die Einzelheiten zusätzliche struktu-

relle Merkmale, wie Türpaneele, Dachluken, Leitern, Fahnenmasten (8) und dergleichen sind.

Revendications

1. Eléments pour un ensemble structurel pour construire, à la manière d'un jeu, des structures tridimensionnelles d'un type de maison à jouer, lesdits éléments comprenant des éléments de base en carton (1, 11, 12) réalisés à partir d'un matériau de carton essentiellement tridimensionnel, lesdits éléments ayant une configuration rectangulaire, dont le dimensionnement est basé sur une mesure latérale modulaire (b), des éléments d'interconnexion (15, 16, 16') comprenant des pièces en un matériau durable pourvu de trous, ainsi que des éléments de serrage (14, 14') s'adaptant dans lesdits trous, lesdits éléments de base en forme de carton (1, 11, 12) et tous les éléments additionnels éventuels (13, 20) comprenant des trous (18, 19) conçus pour lesdits éléments de serrage (14, 14') pour la connexion auxdits éléments d'interconnexion (15, 16, 16') pour l'interconnexion desdits éléments de base (1, 11, 12) et de tous les éléments additionnels éventuels (13, 20) pour constituer une structure de bâtiment tridimensionnelle, le dimensionnement desdits éléments et éléments additionnels (1, 11, 12, 13, 20) à au moins un côté correspondant à un multiple de ladite mesure modulaire (b), et lesdits trous (18, 19) pour lesdits éléments d'interconnexion (14, 14') dans chaque élément, respectivement, étant situés d'une manière modulaire correspondante et en face de trous correspondants (18, 19) dans un autre élément, lesdits trous étant situés, dans une plage de tolérance raisonnable, à une telle distance (c) d'un premier bord extérieur adjacent (10) dudit élément, cette distance correspondant à la moitié de la distance entre des trous correspondants dans l'élément d'interconnexion respectif (15, 16, 16'), caractérisés en ce que les trous respectifs les plus extérieurs (18) pour lesdits éléments d'interconnexion (15, 16, 16') se situent à une telle distance (d) d'un deuxième bord extérieur adjacent (10) qui rejoint ledit premier bord extérieur adjacent, cette distance étant plus grande que la moitié de la distance entre des trous correspondants dans l'élément d'interconnexion respectif (15, 16, 16'), par la largeur (8) dudit élément d'interconnexion respectif (15, 16, 16').
2. Eléments selon la revendication 1, caractérisés en ce que lesdits éléments (1, 11, 12, 13, 20), en plus desdits trous (18) pour lesdits éléments d'interconnexion (15, 16, 16') comprennent d'autres trous (19) pour lesdits éléments d'interconnexion (15, 16, 16'), ces trous (19) se trouvant à une distance nettement plus grande d'au moins un desdits bords (10) dudit élément, mais à la même distance

interne modulaire mutuelle (f).

3. Eléments selon la revendication 1 ou 2, caractérisés en ce que lesdits éléments (1, 11, 12, 13), au moins à un bord (10), comprennent des moyens de renforcement qui agissent d'une manière appropriée simultanément comme éléments d'interconnexion pour la connexion à un ou plusieurs éléments adjacents (1, 11, 12, 13, 20).
4. Eléments selon la revendication 3, caractérisés en ce que lesdits moyens de renforcement comprennent des rebords extérieurs (16') situés au bord extérieur desdits éléments (1, 11, 12, 13, 20), lesdits rebords ont avantageusement une section transversale plane et/ou angulaire et sont réalisés d'une manière appropriée en métal, plastique dur, bois ou analogue.
5. Eléments selon la revendication 3, caractérisés en ce que lesdits moyens de renforcement comprennent des pièces (21) qui sont évidées dans un bord respectif (10) desdits éléments, lesdites pièces présentant d'une manière appropriée auxdits trous (18) un filetage (14b) au analogue à l'intérieur pour ledit élément de serrage respectif (14).
6. Eléments selon l'une des revendications 1 à 5, caractérisés en ce que lesdits éléments (1, 11, 12, 13, 20) sont dimensionnés pour porter, essentiellement d'une manière auto-porteuse, toutes les charges que l'utilisation normale d'une structure de bâtiment assemblée exerce sur ledit élément (1, 11, 12, 13) lorsque ladite structure est utilisée comme maison pour jouer ou analogue.
7. Eléments selon l'une des revendications 1 à 6, caractérisés en ce que lesdits éléments (1, 11, 12, 13, 20) comprennent des détails et/ou des éléments pour encourager le jeu des enfants et/ou l'éducation de l'imagination.
8. Eléments selon la revendication 7, caractérisés en ce que lesdits détails comprennent des ouvertures (4, 5, 6) destinées à représenter des ouvertures (2, 3) présentes dans des bâtiments de grandeur nature.
9. Eléments selon la revendication 7, caractérisés en ce que lesdits détails sont des couleurs et/ou des marques disposées spécifiquement (7) destinées à représenter des fonctions présentes dans la communauté.
10. Eléments selon la revendication 7, caractérisés en ce que lesdits détails sont des caractéristiques structurelles additionnelles comme des panneaux de porte, des panneaux de toit, des échelles, des

poteaux de drapeau (8) et analogues.

5

10

15

20

25

30

35

40

45

50

55

8

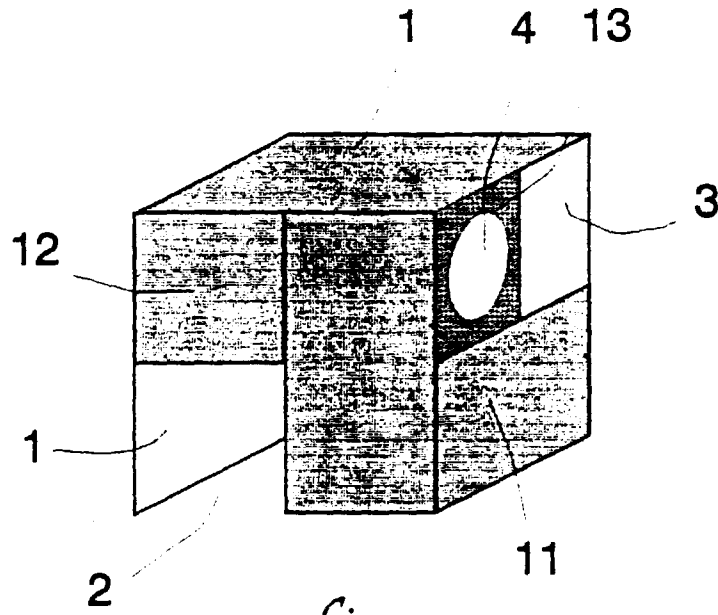

Fig 1

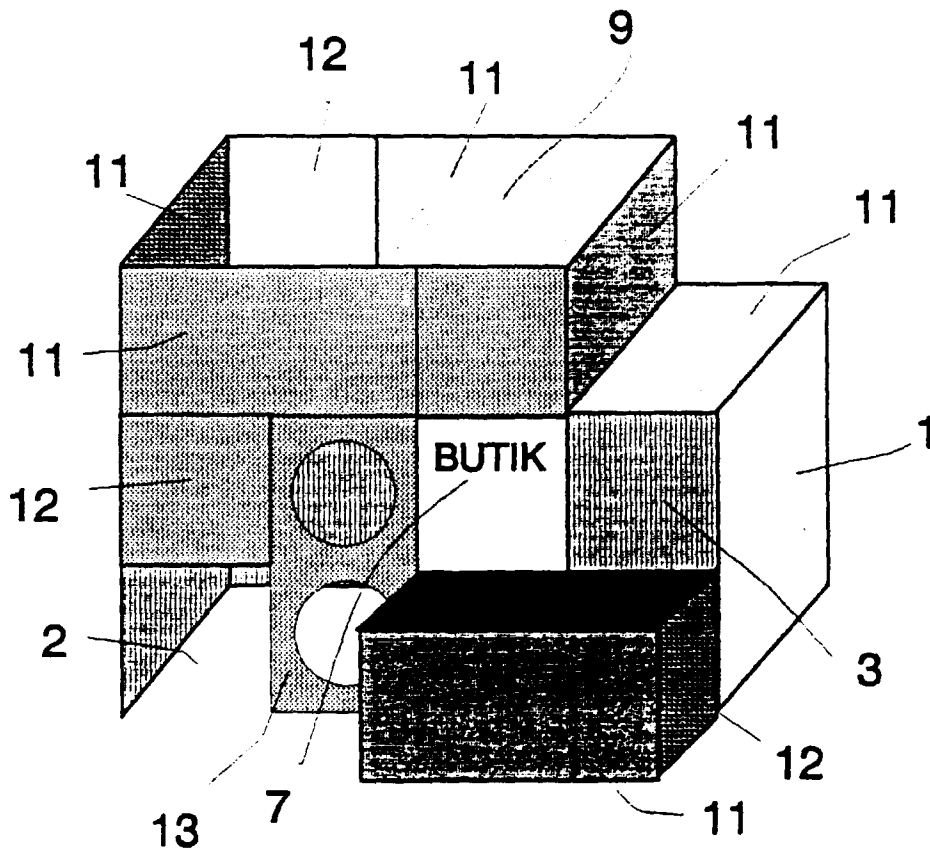
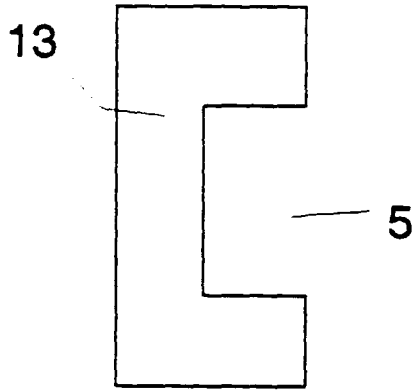
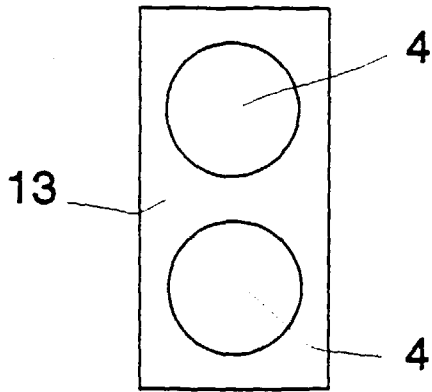

Fig 5



13

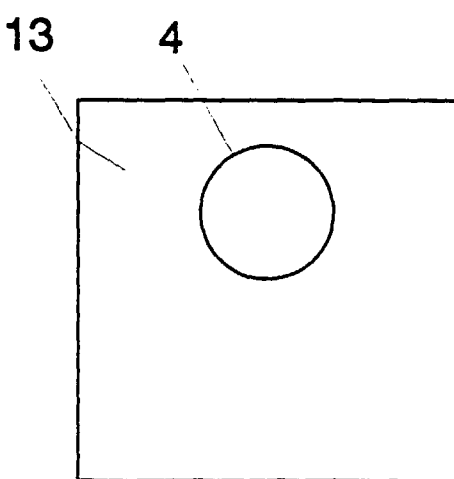
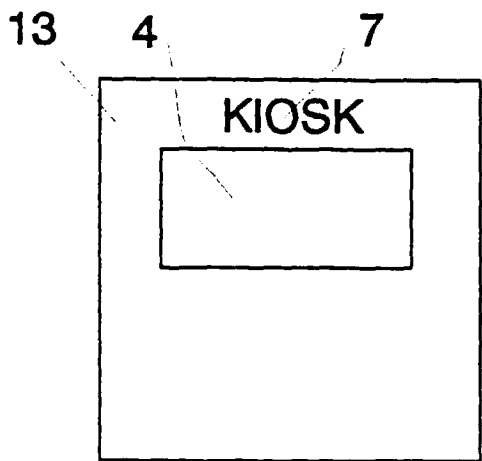
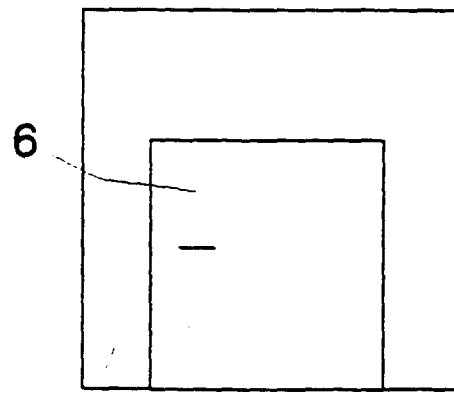
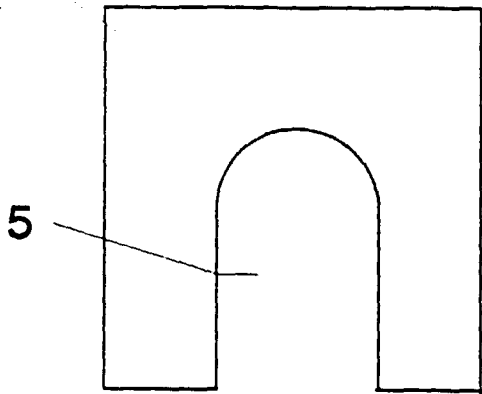

Fig 2

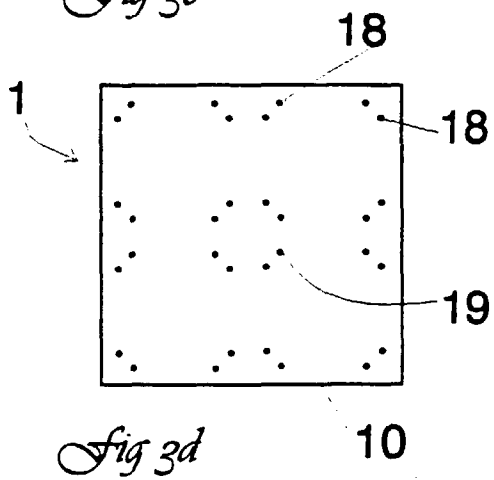
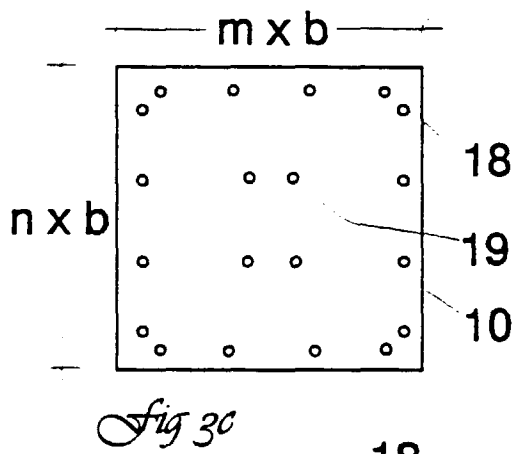
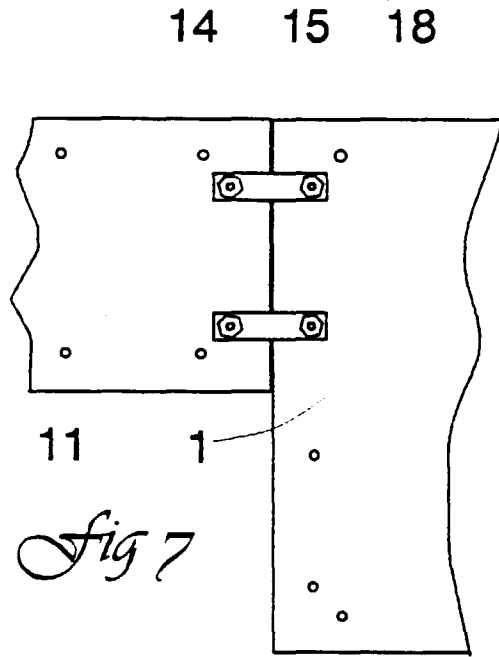
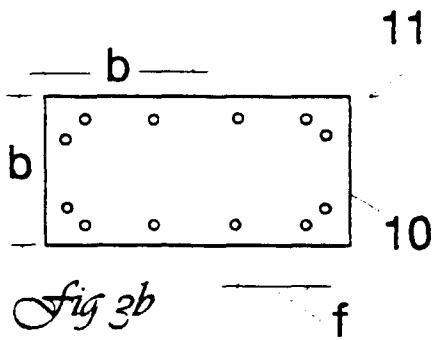
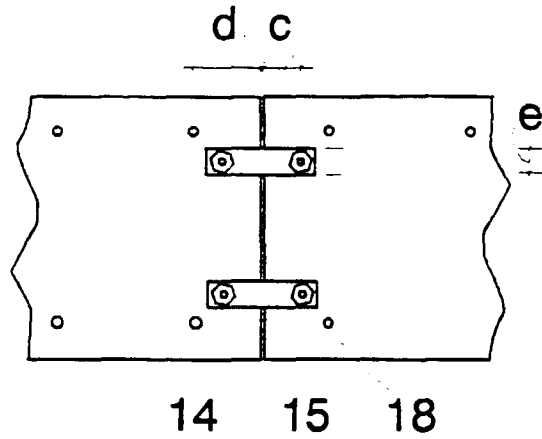
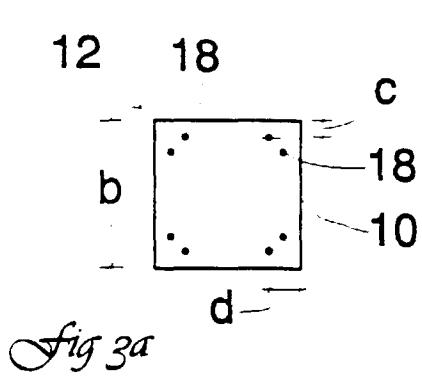
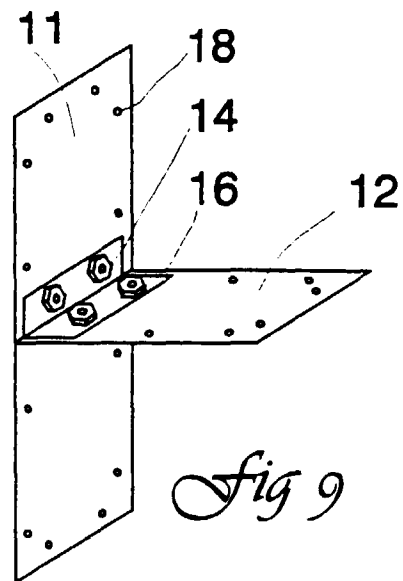

Fig 3



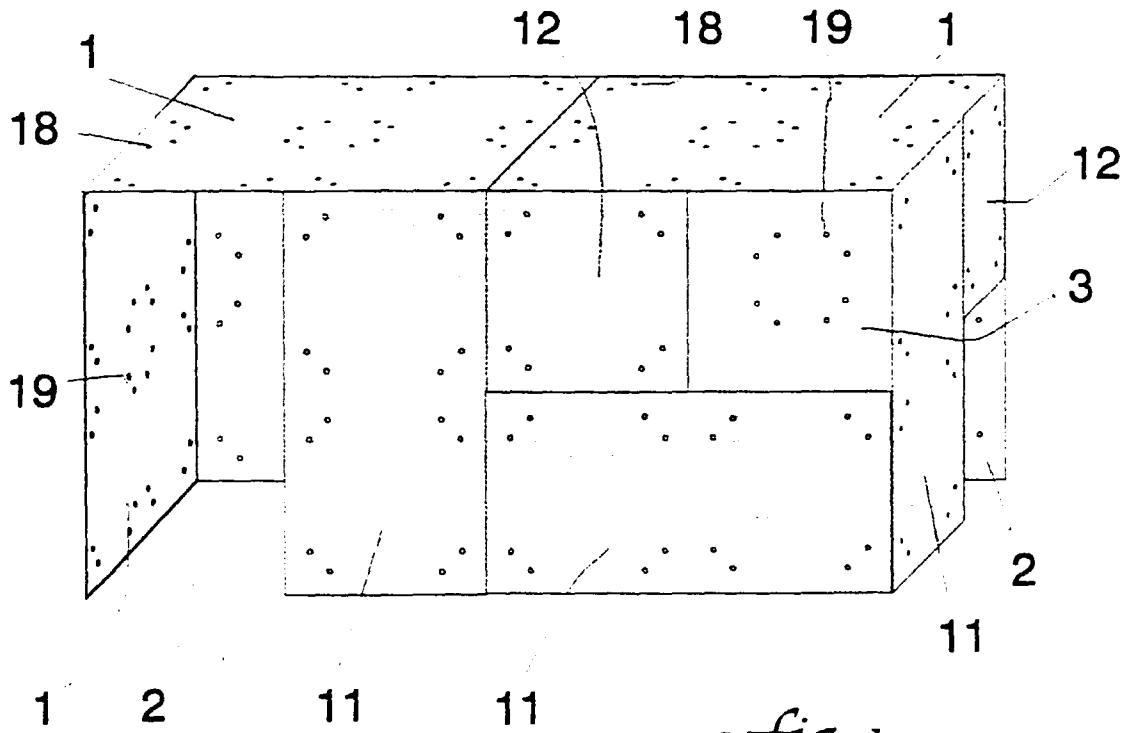

Fig 4

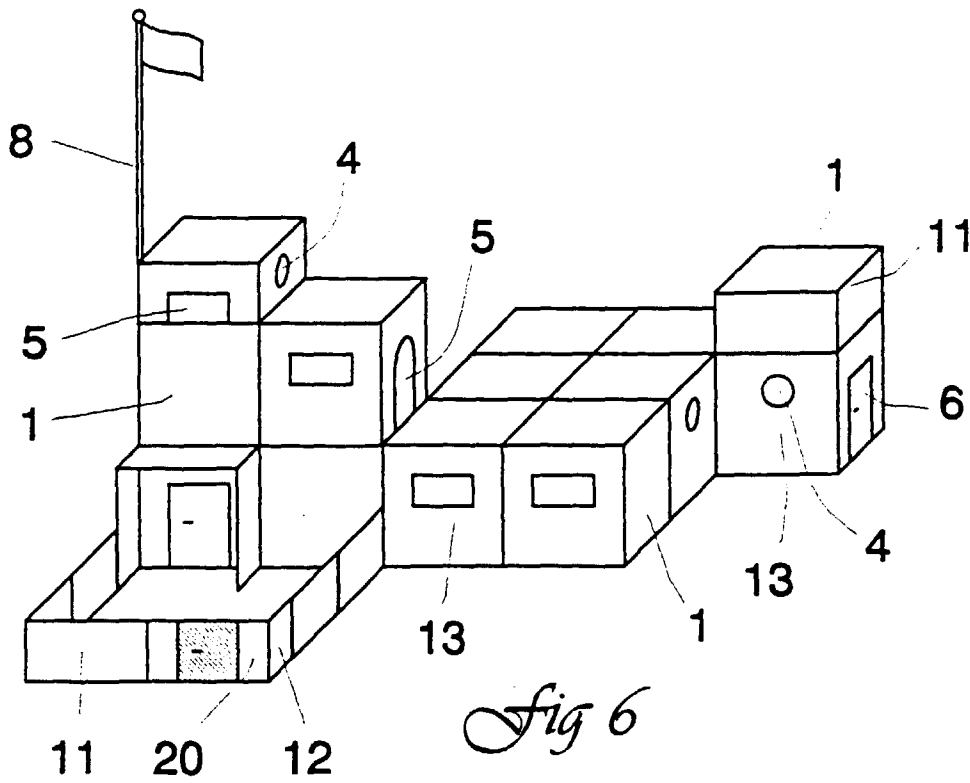

Fig 6

