

(19) World Intellectual Property Organization  
International Bureau



(43) International Publication Date  
6 August 2009 (06.08.2009)

PCT

(10) International Publication Number  
**WO 2009/097027 A1**

- (51) International Patent Classification:  
*B01D 53/50* (2006.01)    *B01J 8/00* (2006.01)  
*B01D 50/00* (2006.01)
- (21) International Application Number:  
PCT/US2008/079321
- (22) International Filing Date: 9 October 2008 (09.10.2008)
- (25) Filing Language: English
- (26) Publication Language: English
- (30) Priority Data:  
11/862,013    31 January 2008 (31.01.2008)    US
- (71) Applicant (for all designated States except US): **CONOCOPHILLIPS COMPANY** [US/US]; 600 N. Dairy Ashford, Houston, Texas 77079 (US).
- (72) Inventors; and
- (75) Inventors/Applicants (for US only): **SCHMIDT, Roland** [DE/US]; 5255 S. Nowata Road, K103, Bartlesville, Oklahoma 74006 (US). **MORTON, Robert, W.** [US/US]; 352 Cr 3105, Bartlesville, Oklahoma 74003 (US). **CROSS, Joseph, B.** [US/US]; 2924 Montrose Drive, Bartlesville, Oklahoma 74006 (US). **SUGHRUE, Edward, L., II**

[US/US]; 6468 Clear Creek Loop, Bartlesville, Oklahoma 74006 (US). **TSANG, Albert, C.** [US/US]; 6411 Aspen Cove Ct., Sugar Land, Texas 77479 (US).

(74) Agent: **FU, Xuping**; Conocophillips Company, IP Services Group, 600 N. Dairy Ashford Bldg. MA-1135, Houston, Texas 77079 (US).

(81) Designated States (unless otherwise indicated, for every kind of national protection available): AE, AG, AL, AM, AO, AT, AU, AZ, BA, BB, BG, BH, BR, BW, BY, BZ, CA, CH, CN, CO, CR, CU, CZ, DE, DK, DM, DO, DZ, EC, EE, EG, ES, FI, GB, GD, GE, GH, GM, GT, HN, HR, HU, ID, IL, IN, IS, JP, KE, KG, KM, KN, KP, KR, KZ, LA, LC, LK, LR, LS, LT, LU, LY, MA, MD, ME, MG, MK, MN, MW, MX, MY, MZ, NA, NG, NI, NO, NZ, OM, PG, PH, PL, PT, RO, RS, RU, SC, SD, SE, SG, SK, SL, SM, ST, SV, SY, TJ, TM, TN, TR, TT, TZ, UA, UG, US, UZ, VC, VN, ZA, ZM, ZW.

(84) Designated States (unless otherwise indicated, for every kind of regional protection available): ARIPO (BW, GH, GM, KE, LS, MW, MZ, NA, SD, SL, SZ, TZ, UG, ZM, ZW), Eurasian (AM, AZ, BY, KG, KZ, MD, RU, TJ, TM), European (AT, BE, BG, CH, CY, CZ, DE, DK, EE, ES, FI, FR, GB, GR, HR, HU, IE, IS, IT, LT, LU, LV, MC, MT, NL,

[Continued on next page]

(54) Title: CONTAMINANT REMOVAL FROM A GAS STREAM

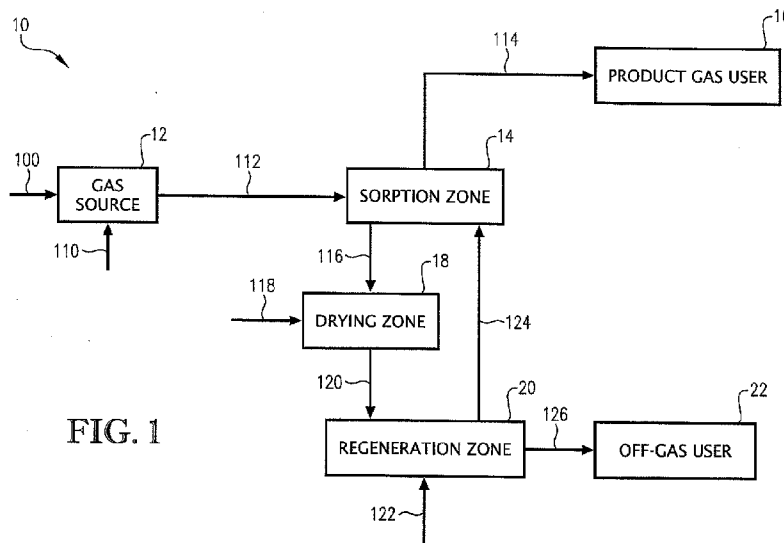

FIG. 1

(57) Abstract: A system employing a regenerable zinc-oxide based sorbent to remove one or more contaminants from an incoming gas stream. The contaminant-depleted gas stream can then be used for any subsequent application, while at least a portion of the contaminant-laden sorbent can be regenerated via a step-wise regeneration process. In one embodiment, sorbent regenerated via the step-wise regeneration process can comprise less sorbent-damaging compounds than traditional sorbents exposed to conventional regeneration processes.

WO 2009/097027 A1



---

NO, PL, PT, RO, SE, SI, SK, TR), OAPI (BF, BJ, CF, CG,  
CI, CM, GA, GN, GQ, GW, ML, MR, NE, SN, TD, TG).

**Published:**  
— *with international search report*

## CONTAMINANT REMOVAL FROM A GAS STREAM

### BACKGROUND OF THE INVENTION

#### 1. Field of the Invention

5           The present invention relates generally to contaminant removal from gas streams. In another aspect, the present invention relates to a process for removing one or more contaminants from a gas stream via contact with a regenerable sorbent.

#### 2. Description of the Prior Art

10           In recent years, the demand for natural gas and other gas-phase fuels has increased substantially. At the same time, stricter regulations concerning allowable levels of certain components (e.g., sulfur species, acid gases, and other compounds of environmental concern) have been imposed, prompting fuel gas producers to develop economical methods of producing a compliant gas product.

15           One known method of treating a gas stream to remove undesirable components is to contact the gas stream with a physical or chemical solvent. Examples of chemical solvents include amines such as methyldiethanolamine (MDEA) and diethanolamine (DEA). Often, the selectivity of the chemical solvents can be problematic. For example, while amines are capable of efficiently removing hydrogen sulfide ( $H_2S$ ) from gas streams, the amines are generally not capable of absorbing other undesirable sulfur-containing compounds, such as, for example carbonyl sulfide (COS). As a result, 20 additional process steps (e.g., COS hydrolysis) must be carried out before the gas stream can be used as fuel. In addition to removing  $H_2S$ , most amines also remove carbon dioxide, which can place unnecessary processing loads on subsequent waste gas facilities. Further, most processes utilizing chemical solvents require extensive cooling 25 of the incoming gas stream and often use large volumes of steam to remove absorbed contaminants from the solvent, which make these processes energy-intensive. Physical solvent-based processes are also highly energy-intensive and often require high operating pressures and/or low operating temperatures.

30           Accordingly, a need exists for an economic process for removing contaminants from a gas stream.

**SUMMARY OF THE INVENTION**

In one embodiment of the present invention, there is provided a process comprising: (a) contacting an sulfur-containing gas stream with an initial sorbent in a sorption zone to thereby produce an sulfur-depleted product stream and a sulfur-laden sorbent, wherein the initial sorbent comprises Zn and a promoter metal; and (b) contacting at least a portion of the sulfur-laden sorbent with a regeneration gas stream in a regeneration zone under regeneration conditions to thereby produce a regenerated sorbent and an off-gas stream, wherein the contacting of step (b) includes introducing the regeneration gas into the regeneration zone at an initial standard gas hourly space velocity (SGHSV) in the range of from about 100 to about 100,000 h<sup>-1</sup>, wherein the contacting of step (b) includes increasing the SGHSV of the regeneration gas to a final SGHSV that is at least 1,000 h<sup>-1</sup> higher than the initial SGHSV.

In another embodiment of the present invention, there is provided a process comprising: (a) introducing a raw gas stream into a sorption zone, wherein the raw gas stream comprises in the range of from about 10 to about 75 volume percent carbon monoxide (CO), in the range of from about 8 to about 50 volume percent hydrogen (H<sub>2</sub>), in the range of from about 4 to about 40 volume percent water (H<sub>2</sub>O), and in the range of from about 0.001 to about 5 volume percent hydrogen sulfide (H<sub>2</sub>S); (b) contacting at least a portion of the raw gas stream with an initial sorbent in the sorption zone to thereby produce a product gas stream and a sulfur-laden sorbent, wherein the initial sorbent comprises Zn and a promoter metal; (c) drying at least a portion of the sulfur-laden sorbent to thereby produce a dried sulfur-laden sorbent; and (d) regenerating at least a portion of the dried sulfur-laden sorbent in a regeneration zone under regeneration conditions to thereby produce a regenerated sorbent and an off-gas stream, wherein the regenerated sorbent comprises less than about 20 weight percent of sorbent-damaging compounds formed during the regenerating of step (d).

In yet another embodiment of the present invention, there is provided a process comprising: (a) gasifying a carbon-containing material in a gasification zone to thereby produce a raw gas stream, wherein the raw gas stream comprises in the range of from about 10 to about 75 volume percent carbon monoxide (CO), in the range of from about 8 to about 50 volume percent hydrogen (H<sub>2</sub>), in the range of from about 4 to about 40

volume percent water (H<sub>2</sub>O), in the range of from about 0.001 to about 5 volume percent sulfur-containing compounds, and in the range of from about 50 to about 2,000 parts per million by volume (ppmv) of hydrochloric acid (HCl); (b) introducing at least a portion of the raw gas stream into a sorption zone, wherein the sorption zone contains an initial sorbent, wherein the initial sorbent comprises Zn, expanded perlite, and a promoter metal, wherein at least a portion of the initial sorbent comprises a substitutional solid solution characterized by the formula  $M_ZZn_{(1-Z)}Al_2O_4$  and a substitutional solid metal solution characterized by the formula  $M_AZn_B$ , wherein M is a promoter metal component and A, B, and Z are in the range of from about 0.01 to about 0.99; (c) sorbing at least a portion of the sulfur-containing compounds from the raw gas stream in the sorption zone with the initial sorbent to thereby produce a sulfur-laden sorbent and a product gas stream, wherein the sorbing is carried out at a temperature in the range of from about 225 to about 550°C and a pressure in the range of from about 250 to about 575 psig, wherein the sulfur-laden sorbent has a sulfur loading in the range of from about 1 to about 27 weight percent, wherein the product gas stream comprises less than 50 ppmv of sulfur-containing materials and less than 20 ppmv of HCl; (d) drying at least a portion of the sulfur-laden sorbent in a drying zone to thereby produce a dried sulfur-laden sorbent; (e) regenerating at least a portion of the dried sulfur-laden sorbent in a regeneration zone via contact with a regeneration gas under regeneration conditions to thereby produce a regenerated sorbent and a SO<sub>2</sub>-containing off-gas, wherein the regeneration gas has an initial standard gas hourly space velocity (SGHSV) in the range of from about 1,000 to about 80,000 h<sup>-1</sup>, wherein the regenerating is carried out with an initial temperature in the range of from about 300 to about 600°C; (f) returning at least a portion of the regenerated sorbent to the sorption zone, wherein the regenerated sorbent returned to the sorption zone comprises a substitutional solid metal oxide solution characterized by the formula  $M_XZn_YO$ , wherein M is a promoter metal component and X and Y are in the range of from about 0.01 to about 0.99, wherein the regenerated sorbent has a sulfur loading of less than 6 weight percent, wherein the regenerated sorbent comprises less than 20 weight percent of sorbent-damaging compounds created during the regenerating of step (e); and (g) routing at least a portion of the SO<sub>2</sub>-containing off-gas stream to a Claus unit.

## BRIEF DESCRIPTION OF THE FIGURES

FIG. 1 is a schematic diagram of a contaminant removal system in accordance with one embodiment of the present invention.

## 5 DETAILED DESCRIPTION

Referring to FIG. 1, a contaminant removal system 10 is illustrated as generally comprising a gas source 12, a sorption zone 14, a product gas user 16, a drying zone 18, a regeneration zone 20, and an off-gas user 22. In general, a raw gas stream exiting gas source 12 can be contacted with a sorbent in sorption zone 14 to thereby remove one or more contaminants from the gas stream. The resulting, contaminant-depleted product gas stream exiting sorption zone 14 can be routed to product gas user 16, while at least a portion of the contaminant-laden sorbent can be dried in drying zone 18 prior to being regenerated via contact with a regeneration gas in regeneration zone 20. The resulting off-gas stream exiting regeneration zone 20 can be routed to off-gas user 22, while at least a portion of the regenerated sorbent can then be returned to sorption zone 14 for subsequent reuse. In one embodiment, at least one of the sorption, drying, and regeneration zones 14, 18, 20 can be contained within the same process vessel. In another embodiment, at least one of the sorption, drying, and regeneration zones 14, 18, 20 can be contained in two or more separate process vessels. Further, the contaminant removal system 10 depicted in FIG. 1 can be operated in continuous, semi-continuous, semi-batch, or batch mode. The operation of contaminant removal system 10 will now be described in more detail below.

Gas source 12 can comprise any source or system capable of producing a gas stream. In general, the raw gas stream produced from gas source 12 can have a vapor fraction greater than about 0.8, greater than about 0.9, or greater than 0.95 at standard conditions. In one embodiment, the raw gas stream from gas source 12 can comprise less than about 1 volume percent, less than about 0.5 volume percent, less than 0.05 volume percent, or less than 500 parts per million by volume (ppmv) of C<sub>6</sub>+ hydrocarbon material. For example, gas source 12 can comprise a natural gas well, a refinery or chemical plant process stream, or any other suitable source.

In one embodiment, gas source 12 can comprise a gasification system operable to produce a raw gas stream via the gasification of a solid-based carbon-containing material, such as, for example, coal or petroleum coke. Typically, the solid carbon-containing material can be gasified via contact with a gasification stream comprising steam, oxygen, air, hydrogen, carbon dioxide, or any combination thereof. In one embodiment, a slurry of solid carbon-containing material in conduit 100 can be gasified via contact with an oxygen-containing stream entering gas source 12 via conduit 110 at a temperature in the range of from about 530 to about 1950°C, about 810 to about 1650°C, or 950 to 1510°C and a pressure in the range of from about 150 to about 800 pounds-per-square inch, gauge (psig), about 250 to about 700 psig, or 300 to 600 psig.

The raw gas stream exiting gas source 12 via conduit 112 can comprise one or more of the following compounds: carbon monoxide (CO), carbon dioxide (CO<sub>2</sub>), hydrogen (H<sub>2</sub>), water (H<sub>2</sub>O), propane and lighter hydrocarbons (C<sub>3</sub>+), nitrogen (N<sub>2</sub>), and the like. Additionally, the raw gas stream can comprise one or more undesirable components (i.e., contaminants) that should be removed prior to utilizing the raw gas stream as fuel. Sulfur compounds, such as, for example, hydrogen sulfide (H<sub>2</sub>S), carbonyl sulfide (COS), carbon disulfide (CS<sub>2</sub>), and even organosulfur compounds such as mercaptans and various thiophenic compounds are a few examples of common contaminants found in the raw gas stream. Other examples of contaminants typically present in the raw gas stream can include, but are not limited to ammonia (NH<sub>3</sub>), hydrochloric acid (HCl), and hydrogen cyanide (HCN).

Table 1, below, summarizes the composition of the raw gas stream in conduit 112 according to one embodiment of the present invention.

25

30

<b>Table 1</b>			
<b>Component</b>	<b>Component in Raw Gas Stream (based on total stream volume)</b>		
	<b>Broad Range</b>	<b>Intermediate Range</b>	<b>Narrow Range</b>
H <sub>2</sub>	8 – 50 vol %	10 – 40 vol %	15 – 35 vol %
CO	10 – 75 vol %	15 – 60 vol %	25 – 50 vol %
CO <sub>2</sub>	1 – 40 vol %	5 – 30 vol %	7 – 20 vol %
H <sub>2</sub> O	4 – 40 vol %	8 – 30 vol %	10 – 25 vol %
H <sub>2</sub> S	0.001 – 5 vol %	0.1 – 2.5 vol %	0.5 – 2 vol %
CH <sub>4</sub>	0.05 – 10 vol %	0.1 to 7.5 vol %	0.5 to 5.0 vol %
COS	100 – 5,000 ppmv	200 – 2,500 ppmv	350 – 1,500 ppmv
HCl	50 – 2,000 ppmv	100 – 1,500 ppmv	250 – 1,000 ppmv
NH <sub>3</sub>	50 – 2,000 ppmv	100 – 1,500 ppmv	250 – 1,000 ppmv
Other (total)	< 2.5 vol %	< 2.0 vol %	< 1 vol %

As depicted in FIG 1, at least a portion of the raw gas stream exiting gas source 5  
 12 in conduit 112 can be routed into sorption zone 14, wherein the stream can be  
 contacted with a sorbent to remove at least a portion of at least one contaminant from the  
 incoming gas stream. In one embodiment, the raw gas stream is not cooled prior to  
 entering sorption zone 14 and can have a temperature that is within about 200°C, about  
 100°C, or 50°C of the temperature of the raw gas stream exiting gas source 12.  
 10 Generally, the raw gas stream entering sorption zone 14 can have a temperature in the  
 range of from about 150 to about 700°C, about 250 to about 600°C, or 350 to 450°C and  
 a pressure in the range of from about 100 to about 750 psig, about 250 to about 600 psig,  
 or 350 to 450 psig.

In general, the sorbent employed in sorption zone 14 can be any sufficiently  
 15 regenerable zinc-oxide-based sorbent composition having sufficient contaminant  
 removal ability. While described below in terms of its ability to remove sulfur  
 contaminants from an incoming gas stream, it should be understood that the sorbent of



the present invention can also have significant capacity to remove one or more other contaminants, such as, for example, one or more of the contaminants listed above.

In one embodiment of the present invention, the sorbent employed in sorption zone 14 can comprise zinc and a promoter metal component. The promoter metal component can comprise one or more promoter metal selected from the group consisting of nickel, cobalt, iron, manganese, tungsten, silver, gold, copper, platinum, zinc, tin, ruthenium, molybdenum, antimony, vanadium, iridium, chromium, palladium, and mixtures thereof. In one embodiment, at least a portion of the promoter metal component is present in a reduced-valence state. The valence reduction of the promoter metal component can be achieved by contacting the sorbent with a hydrogen-containing stream within sorption zone 14 and/or prior to introduction into sorption zone 14.

In one embodiment of the present invention, the reduced-valence promoter metal component can comprise, consist of, or consist essentially of, a substitutional solid metal solution characterized by the formula:  $M_AZn_B$ , wherein M is the promoter metal and A and B are each numerical values in the range of from about 0.01 to about 0.99. In the above formula for the substitutional solid metal solution, A can be in the range of from about 0.70 to about 0.98 or 0.85 to 0.95 and B can be in the range of from about 0.03 to about 0.30 or 0.05 to 0.15. In one embodiment,  $A + B = 1$ .

Substitutional solid solutions are a subset of alloys that are formed by the direct substitution of the solute metal for the solvent metal atoms in the crystal structure. For example, it is believed that the substitutional solid metal solution  $M_AZn_B$  is formed by the solute zinc metal atoms substituting for the solvent promoter metal atoms. Three basic criteria exist that favor the formation of substitutional solid metal solutions: (1) the atomic radii of the two elements are within 15 percent of each other; (2) the crystal structures of the two pure phases are the same; and (3) the electronegativities of the two components are similar. The promoter metal (as the elemental metal or metal oxide) and zinc (as the elemental metal or metal oxide) employed in the sorbent described herein typically meet at least two of the three criteria set forth above. For example, when the promoter metal is nickel, the first and third criteria, are met, but the second is not. The nickel and zinc metal atomic radii are within 10 percent of each other and the electronegativities are similar. However, nickel oxide (NiO) preferentially forms a cubic

crystal structure, while zinc oxide (ZnO) prefers a hexagonal crystal structure. A nickel zinc solid solution retains the cubic structure of the nickel oxide. Forcing the zinc oxide to reside in the cubic structure increases the energy of the phase, which limits the amount of zinc that can be dissolved in the nickel oxide structure. This stoichiometry control manifests itself microscopically in a 92:8 nickel zinc solid solution ( $\text{Ni}_{0.92}\text{Zn}_{0.08}$ ) that is formed during reduction and microscopically in the repeated regenerability of sorbent.

In addition to zinc and the promoter metal, the sorbent employed in sorption zone 14 can further comprise a porosity enhancer (PE) and an aluminate. The aluminate can comprise a promoter metal-zinc aluminate substitutional solid solution characterized by the formula:  $\text{M}_Z\text{Zn}_{(1-Z)}\text{Al}_2\text{O}_4$ , wherein M is the promoter metal and Z is in the range of from 0.01 to 0.99. The porosity enhancer, when employed, can be any compound which ultimately increases the macroporosity of the sorbent. In one embodiment, the porosity enhancer can comprise perlite. Examples of sorbents suitable for use in sorption zone 14 and methods of making these sorbents are described in detail in U.S. Patent Nos., 6,429,170 and 7,241,929, the entire disclosures of which are incorporated herein by reference.

Table 2, below, provides the composition of a sorbent employed in sorption zone 14 according to an embodiment of the present invention where reduction of the sorbent is carried out prior to introduction of the sorbent into sorption zone 14.

<b>Table 2</b>				
<b>Range</b>	<b>Reduced Sorbent Composition (wt %)</b>			
	<b>ZnO</b>	<b><math>\text{M}_A\text{Zn}_B</math></b>	<b>PE</b>	<b><math>\text{M}_Z\text{Zn}_{(1-Z)}\text{Al}_2\text{O}_4</math></b>
Broad	10-90	5-80	2-50	2-50
Intermediate	20-60	10-60	5-30	5-30
Narrow	30-40	30-40	10-20	10-20

20

In an alternative embodiment where the sorbent is not reduced prior to introduction into sorption zone 14, the promoter metal component can comprise a substitutional solid metal oxide solution characterized by the formula  $\text{M}_X\text{Zn}_Y\text{O}$ , wherein M is the promoter metal and X and Y are in the range of from about 0.01 to about 0.99. In one embodiment, X can be in the range of from about 0.5 to about 0.9, about 0.6 to about 0.8, or 0.65 to 0.75 and Y can be in the range of from about 0.10 to about 0.5, about 0.2 to about 0.4, or 0.25 to 0.35. In general,  $X + Y = 1$ .

25

Table 3, below, provides the composition of an unreduced sorbent employed in sorption zone 14 according to an embodiment where the sorbent is not reduced prior to introduction into sorption zone 14.

<b>Table 3</b>				
<b>Range</b>	<b>Unreduced Sorbent Composition (wt %)</b>			
	<b>ZnO</b>	<b>M<sub>x</sub>Zn<sub>y</sub>O</b>	<b>PE</b>	<b>M<sub>z</sub>Zn<sub>(1-z)</sub>Al<sub>2</sub>O<sub>4</sub></b>
Broad	10-90	5-70	2-50	2-50
Intermediate	20-70	10-60	5-30	5-30
Narrow	35-45	25-35	10-20	10-20

5 As mentioned above, when an unreduced sorbent composition is contacted with a hydrogen containing compound in sorption zone 14, reduction of the sorbent can take place in sorption zone 14. Therefore, when sorbent reduction takes place in sorption zone 14, the initial sorbent contacted with the raw gas stream in sorption zone 14 can be a mixture of reduced sorbent (Table 2) and unreduced sorbent (Table 3).

10 In general, the incoming raw gas stream can contact the initial sorbent in sorption zone 14 at a temperature in the range of from about 150 to about 650°C, about 225 to about 550°C, or 325 to 475°C and a pressure in the range of from about 100 to about 750 psig, about 250 to 575 psig, or 350 to 450 psig. At least a portion of sulfur-containing compounds (and/or other contaminants) in the raw gas stream can be sorbed by the sorbent, thereby creating a sulfur-depleted product gas stream and a sulfur-laden sorbent.  
 15 In one embodiment, sulfur-removal efficiency of sorption zone 14 can be greater than about 85 percent, greater than about 90 percent, greater than about 95 percent, greater than about 98 percent, or greater than 99 percent.

20 As depicted in FIG. 1, at least a portion of the contaminant-depleted product gas stream can exit sorption zone 14 via conduit 114. In one embodiment, the product gas stream can comprise less than about 50, less than about 20, less than about 10, less than about 5, or less than 1 ppmv H<sub>2</sub>S. In addition, the product gas stream can comprise less than about 20, less than about 10, less than about 5, or less than 2 ppmv of HCl and/or COS. This is in contrast to conventional sulfur removal sorbents, which are often  
 25 incapable of effectively removing sulfur-containing compounds such as H<sub>2</sub>S and COS simultaneously with other contaminants such as HCl.

As shown in FIG. 1, the contaminant-depleted product gas stream can then be routed to a product gas user 16. Product gas user 16 can comprise any industrial, commercial, or residential use or application of a contaminant-depleted product gas stream. In one embodiment, product gas user 16 can comprise an industrial gas turbine  
5 located in a facility used to co-produce steam and electricity.

As depicted in FIG. 1, at least a portion of the sulfur-laden sorbent discharged from sorption zone 14 can be routed to drying zone 18 via conduit 116. In one embodiment, the sulfur-laden sorbent can have a sulfur loading in the range of from about 1 to about 27, about 3 to about 26, about 5 to about 25, or 10 to 20 weight percent.  
10 In drying zone 18, at least a portion of the sulfur-laden sorbent can be dried by flowing an inert gas purge stream in conduit 118 having a temperature in the range of from about 100 to about 550°C, about 150 to about 500°C, or 200 to 475°C through the sorbent for a time period of at least about 15 minutes, or a time period in the range of from about 30 minutes to about 100 hours, about 45 minutes to about 36 hours, or 1 hour to 12 hours.  
15 The resulting dried, sulfur-laden sorbent can then be routed to regeneration zone 20 via conduit 120, as illustrated in FIG. 1.

Regeneration zone 20 can employ a regeneration process capable of removing least a portion of the sulfur (or other sorbed contaminants) from the sulfur-laden sorbent via contact with a regeneration gas stream under sorbent regeneration conditions. In one  
20 embodiment, the regeneration gas stream entering regeneration zone 20 via conduit 122 can comprise an oxygen-containing gas stream, such as, for example, air (e.g., about 21 volume percent oxygen). In another embodiment, the regeneration gas stream in conduit 120 can be an oxygen-enriched gas stream comprising at least about 50, at least about 75, at least about 85, or at least 90 volume percent oxygen. In yet another embodiment, the  
25 regeneration gas stream can comprise a substantially pure oxygen stream.

According to one embodiment of the present invention, the regeneration process employed in regeneration zone 20 can be a step-wise regeneration process. In general, a step-wise regeneration process includes adjusting at least one regeneration variable from an initial value to a final value in two or more incremental adjustments (i.e., steps).  
30 Examples of adjustable regeneration variables can include, but are not limited to, temperature, pressure, and regeneration gas flow rate. In one embodiment, the

temperature in regeneration zone 20 can be increased by a total amount that is at least about 75°C, at least about 100°C, or at least 150°C above an initial temperature, which can be in the range of from about 250 to about 650°C, about 300 to about 600°C, or 350 to 550°C. In another embodiment, the regeneration gas flow rate can be adjusted so that the standard gas hourly space velocity (SGHSV) of the regeneration gas in contact with the sorbent can increase by a total amount that is at least about 1,000, at least about 2,500, at least about 5,000, or at least 10,000 volumes of gas per volume of sorbent per hour (v/v/h or h<sup>-1</sup>) above an initial SGHSV value, which can be in the range of from about 100 to about 100,000 h<sup>-1</sup>, about 1,000 to about 80,000 h<sup>-1</sup>, or 10,000 to 50,000 h<sup>-1</sup>.

In one embodiment, the size of the incremental adjustments (i.e., the incremental step size) can be in the range of from about 2 to about 50, about 5 to about 40, or 10 to 30 percent of magnitude of the desired overall change (i.e., the difference between the final and initial values). For example, if an overall temperature change of about 150°C is desired, the incremental step size can be in the range of from about 3 to about 75°C, about 7.5 to about 60°C, or 15 to 45°C. In another embodiment, the magnitude of the incremental step size can be in the range of from about 2 to about 50, about 5 to about 40, or 10 to 30 percent of magnitude of the initial variable value. For example, if the initial regeneration temperature is 250°C, the incremental step size can be in the range of from about 5 to about 125°C, about 12.5 to about 100°C, or 25 to 75°C. In general, successive incremental steps can have the same incremental step sizes, or, alternatively, one or more incremental step sizes can be greater than or less than the incremental step size of the preceding or subsequent steps.

In one embodiment, subsequent adjustments to the regeneration variable(s) can be carried out at predetermined time intervals. For example, adjustments can be made after time intervals in the range of from about 1 minute to about 45 minutes, about 2 minutes to about 30 minutes, or 5 to 20 minutes. In another embodiment, the adjustments can be made based on the value(s) of one or more "indicator" variable(s). An indicator variable is a variable in the system monitored to determine the progress of the sorbent regeneration. Examples of indicator variables can include, but are not limited to, sorbent carbon or sulfur loading, regeneration sorbent bed temperature, regeneration zone temperature profile (i.e., exotherm), and off-gas stream composition. In one

embodiment, the sulfur dioxide (SO<sub>2</sub>) concentration in the off-gas stream is monitored to determine when the flow rate of the regeneration gas and/or the regeneration temperature are incrementally adjusted.

5 The regeneration process can be carried out in regeneration zone 20 until at least one regeneration end point is achieved. In one embodiment, the regeneration end point can be the achievement of a desired value for one or more of the adjusted regeneration variables. For example, the regeneration process can be carried out until the temperature achieves a final value in the range of from about 300 to about 800°C, about 350 to about 750°C, or 400 to 700°C or the SGHSV reaches a final value in the range of from about 1,100 to about 110,000 h<sup>-1</sup>, about 5,000 to about 85,000 h<sup>-1</sup>, or 25,000 to 60,000 h<sup>-1</sup>. In another embodiment, the regeneration process can be finished after a predetermined number of variable adjustments. For example, the regeneration process can be carried out long enough for at least 1 or in the range of from about 2 to about 8 or 3 to 5 incremental adjustments to be made. In yet another embodiment, the regeneration process can be carried out until a final value of the selected indicator variable is achieved. For example, the regeneration process can be carried out until the concentration of SO<sub>2</sub> in the off-gas exiting regeneration zone 20 declines to a value less than about 1 volume percent, less than about 0.5 volume percent, less than about 0.1 volume percent, or less than 500 ppmv. Regardless of the specific endpoint selected, the entire length of the regeneration process can be less than about 100 hours, or in the range of from about 30 minutes to about 48 hours, about 45 minutes to about 24 hours, or 1.5 to 12.5 hours.

25 In one embodiment, the above-described regeneration process can have a regeneration efficiency of at least about 75 percent, at least about 85 percent, at least about 90 percent, at least about 95 percent, at least about 98 percent, or at least 99 percent. The regenerated sorbent can have a sulfur loading that is less than about 10 weight percent, or in the range of from about 0.05 to about 6 weight percent, or 0.1 to 4 weight percent.

30 In general, regenerating at least a portion of the above-described sorbent can result in the formation of one or more sorbent-damaging compounds. A sorbent-damaging compound can be any compound sorbed into or onto the sorbent that adversely

impacts the sorbent's ability to sorb sulfur from the incoming gas stream in sorption zone 14. Examples of sorbent-damaging compounds can include, but are not limited to, zinc oxy-sulfate and zinc silicate. In one embodiment of the present invention, the regenerated sorbent exposed to the above-described regeneration process in regeneration zone 20 can comprise less than expected amounts of sorbent-damaging compounds as compared to traditional sorbents exposed to conventional regeneration processes. For example, the regenerated sorbent exiting regeneration zone via conduit 124 can comprise less than about 20 weight percent sorbent-damaging compounds or in the range of from 0 to about 15 weight percent, or 0 to about 10 weight percent, or 0 to 5 weight percent of sorbent-damaging compounds.

As illustrated in FIG. 1, at least a portion of the regenerated sorbent in conduit 124 can then be returned to sorption zone 14. As discussed above, in one embodiment, at least a portion of the regenerated sorbent does not undergo a reduction step prior to introduction into sorption zone. In such an embodiment, the regenerated but unreduced sorbent introduced into sorption zone 14 can comprise an unreduced promoter metal component that includes a substitutional solid metal oxide solution characterized by the formula  $M_xZn_yO$  (See e.g., Table 3, above).

Referring back to FIG. 1, the off-gas stream exiting regeneration zone 20 via conduit 126 can subsequently be routed to off-gas user 22. Off-gas user 22 can comprise any unit capable of processing the off-gas stream, such as, for example, a Claus sulfur processing unit. In one embodiment, the off-gas stream exiting regeneration zone 20 via conduit 126 can comprise at least about 5, at least about 10, at least about 20, or at least 25 volume percent  $SO_2$ . In one embodiment, the off-gas stream comprises less  $H_2S$  than in the raw gas stream entering sorption zone 14 via conduit 112. In another embodiment, off-gas stream can comprise substantially no  $H_2S$ .

The following example is intended to be illustrative of one embodiment of the present invention in order to teach one of ordinary skill in the art to make and use the invention and is not intended to limit the scope of the invention in any way.

### 30 **EXAMPLE**

An unreduced Zn-promoter metal sorbent (SZorb<sup>TM</sup> Generation IV sorbent commercially available from Sud-Chemie Inc. of Louisville, Kentucky) was crushed and

sieved to obtain 100+/200-mesh size particles. Fifteen grams of the crushed sorbent was combined with 45 grams of alundum and the resulting mixture was charged to a fixed bed, downflow reaction vessel. A raw gas stream, the composition of which is summarized in Table 4 below, was passed through the reaction vessel and contacted with the sorbent mixture at a temperature of 420°C and a pressure of 408 psig.

<b>Component</b>	<b>Amount (vol %)</b>	<b>Component</b>	<b>Amount (vol %)</b>
CO	38.6	N <sub>2</sub>	1.3
H <sub>2</sub>	25.6	Ar	0.9
CO <sub>2</sub>	14.6	COS	0.2
H <sub>2</sub> O	15.7	HCl	0.02
CH <sub>4</sub>	1.7	NH <sub>3</sub>	0.07
H <sub>2</sub> S	1.2	HCN	0.01

The concentration of sulfur compounds (i.e., H<sub>2</sub>S and COS) in the product gas stream exiting the reaction vessel was continuously monitored using an online sulfur analyzer (Model 902D2, available from Galvanic Applied Sciences USA, Inc. of Lowell, Massachusetts), while the concentrations of the remaining compounds were measured with an online mass spectrometer (EcoSys™, commercially available from European Spectrometry Systems, Ltd. of Northwich, Cheshire, United Kingdom). Sulfur “breakthrough” occurred after 1.5 hours when the concentration of sulfur compounds in the gas stream exiting the reaction vessel exceeded 0.1 volume percent (i.e., 1000 ppmv). Once breakthrough was observed, the flow of feed gas to the reaction vessel was stopped and several sulfur-laden sorbent samples from various locations throughout the sorbent bed were removed for subsequent analysis. The sulfur-laden sorbent had an average sulfur loading of 25.9 weight percent, as determined by X-ray fluorescence (XRF) analysis.

The sulfur-laden sorbent remaining in the reaction vessel was purged with a stream of nitrogen having a temperature of 400°C and a flow rate of 100 mL/min to dry the sorbent prior to regeneration. After one hour, regeneration was initiated by



introducing a stream of air having a flow rate of 100 mL/min to the sorbent bed, which had an initial temperature of 400°C. Both the regeneration temperature (in 30-50°C increments) and the air flow rate (in 100 to 250 mL/min increments) were adjusted to maintain reasonably consistent concentrations of sulfur dioxide in the off-gas stream exiting the reaction vessel. When SO<sub>2</sub> levels declined substantially, the regeneration process was stopped and several regenerated sorbent samples were taken at various locations throughout the bed. Subsequent XRF analysis showed the regenerated sorbent had an average sulfur loading of 3.52 weight percent and the XRD analysis revealed the average combined amount of zinc oxysulfate and zinc silicate (i.e., sorbent-damaging compounds) to be 10.1 percent.

### NUMERICAL RANGES

The present description uses numerical ranges to quantify certain parameters relating to the invention. It should be understood that when numerical ranges are provided, such ranges are to be construed as providing literal support for claim limitations that only recite the lower value of the range as well as claims limitation that only recite the upper value of the range. For example, a disclosed numerical range of 10 to 100 provides literal support for a claim reciting "greater than 10" (with no upper bounds) and a claim reciting "less than 100" (with no lower bounds).

### DEFINITIONS

As used herein, the terms "a," "an," "the," and "the" mean one or more.

As used herein, the term "and/or," when used in a list of two or more items, means that any one of the listed items can be employed by itself or any combination of two or more of the listed items can be employed. For example, if a composition is described as containing components A, B, and/or C, the composition can contain A alone; B alone; C alone; A and B in combination; A and C in combination; B and C in combination; or A, B, and C in combination.

As used herein, the terms "comprising," "comprises," and "comprise" are open-ended transition terms used to transition from a subject recited before the term to one or

more elements recited after the term, where the element or elements listed after the transition term are not necessarily the only elements that make up the subject.

As used herein, the terms “containing,” “contains,” and “contain” have the same open-ended meaning as “comprising,” “comprises,” and “comprise” provided above.

5 As used herein, the terms “including,” “includes,” and “include” have the same open-ended meaning as “comprising,” “comprises,” and “comprise” provided above.

As used herein, the terms “having,” “has,” and “have” have the same open-ended meaning as “comprising,” “comprises,” and “comprise” provided above.

10 As used herein, the terms, “including,” “include,” and “included” have the same open-ended meaning as “comprising,” “comprises,” and “comprise” provided above.

As used herein, the term “indicator variable” refers to a variable monitored to determine the progress of the sorbent regeneration.

As used herein, the term “reduced-valence promoter metal component” refers to a promoter metal component having a valence with is less than the valence of the promoter metal component in its common oxidized state.

As used herein, the term “regeneration conditions” refer to conditions necessary to remove at least a portion of sorbed sulfur from the sulfur-laden sorbent.

As used herein, the term “regeneration efficiency” refers to the ability of a regeneration zone to remove one or more sorbed compounds from an incoming sorbent. Regeneration efficiency can be expressed according to the following formula: [(sulfur loading of sulfur-laden sorbent x mass of sulfur-laden sorbent entering regeneration zone) – (sulfur loading of regenerated sorbent x mass of regenerated sorbent exiting regeneration zone) / (sulfur loading of sulfur-laden sorbent x mass of sulfur-laden sorbent entering regeneration zone), expressed as a percentage.

25 As used herein, the term “sorb” refers to any type or combination of physical and/or chemical adsorption and/or absorption.

As used herein, the term “sorbent-damaging compound” refers to a compound sorbed into or onto the sorbent that adversely impacts the sorbent’s ability to remove sulfur or other contaminants from a fluid stream.

30 As used herein, the term “standard conditions” refers to a pressure of 1 atmosphere and a temperature of 60°F.

As used herein, the term “standard gas hourly space velocity” or “SGHSV” refers to the gas hourly space velocity of a gas stream measured at standard conditions.

As used herein, the term “sulfur loading” refers to the average weight percent of sulfur sorbed onto a sorbent.

5 As used herein, the term “sulfur removal efficiency” refers to the ability of a sorbent to remove sulfur compounds or other contaminants from an incoming fluid stream. Sulfur removal efficiency can be calculated by the following formula: (mass flow rate of sulfur compounds entering a sorption zone in a fluid stream – mass flow rate of sulfur compounds exiting a sorption zone in a fluid stream) / (mass flow rate of sulfur  
10 compounds entering a sorption zone in the feed stream), expressed as a percentage.

#### **CLAIMS NOT LIMITED TO THE DISCLOSED EMBODIMENTS**

The preferred forms of the invention described above are to be used as illustration only, and should not be used in a limiting sense to interpret the scope of the present  
15 invention. Modifications to the exemplary embodiments, set forth above, could be readily made by those skilled in the art without departing from the spirit of the present invention.

The inventors hereby state their intent to rely on the Doctrine of Equivalents to determine and assess the reasonably fair scope of the present invention as pertains to any  
20 apparatus not materially departing from but outside the literal scope of the invention as set forth in the following claims.

**CLAIMS**

What is claimed is:

1. A process comprising:
  - 5 (a) contacting an sulfur-containing gas stream with an initial sorbent in a sorption zone to thereby produce an sulfur-depleted product stream and a sulfur-laden sorbent, wherein said initial sorbent comprises Zn and a promoter metal; and
  - (b) contacting at least a portion of said sulfur-laden sorbent with a regeneration gas stream in a regeneration zone under regeneration conditions to thereby produce a regenerated sorbent and an off-gas stream,
- 10 wherein said contacting of step (b) includes introducing said regeneration gas into said regeneration zone at an initial standard gas hourly space velocity (SGHSV) in the range of from about 100 to about 100,000 h<sup>-1</sup>, wherein said contacting of step (b) includes increasing the SGHSV of said regeneration gas to a final SGHSV that is at least 1,000 h<sup>-1</sup> higher than said initial SGHSV.
- 15
2. The process of claim 1, wherein said contacting of step (b) further comprises increasing the temperature of said regeneration zone by at least 75°C.
3. The process of claim 2, wherein said contacting of step (b) further
- 20 comprises alternating said increasing the temperature of said regeneration zone and said increasing the SGHSV of said regeneration gas, wherein said alternating is carried out until said off-gas stream comprises less than about 0.05 volume percent sulfur dioxide (SO<sub>2</sub>).
- 25
4. The process of claim 1, wherein said contacting of step (b) is carried out at a temperature less than 650°C for a period of time less than 24 hours .
5. The process of claim 1, wherein said sulfur-laden sorbent has a sulfur loading in the range of from about 1 to about 27 weight percent, wherein said
- 30 regenerated sorbent has a sulfur loading of less than 10 weight percent.

6. The process of claim 1, wherein said promoter metal is nickel.

7. The process of claim 1, wherein said initial sorbent comprises a substitutional solid metal solution characterized by the formula  $M_AZn_B$ , wherein M is said promoter metal, wherein A and B are in the range of from about 0.01 to about 0.99.

8. The process of claim 1, further comprising, prior to step (b), drying at least a portion of said sulfur-laden sorbent to thereby provide a dried sulfur-laden sorbent and subjecting at least a portion of said dried sulfur-laden sorbent to said contacting of step (b).

9. The process of claim 8, wherein said sulfur-containing gas stream comprises in the range of from about 4 to about 40 volume percent water, wherein said regenerated sorbent comprises in the range of from 0 to about 10 weight percent of sorbent-damaging compounds created during said contacting of step (b).

10. The process of claim 9, wherein said sulfur-containing gas stream further comprises in the range of from about 10 to about 75 volume percent carbon monoxide (CO) and in the range of from about 8 to about 50 volume percent hydrogen (H<sub>2</sub>).

11. The process of claim 1, wherein said sulfur-containing gas stream comprises in the range of from about 0.001 to about 5 volume percent H<sub>2</sub>S, wherein said sulfur-depleted product stream comprises less than 50 ppmv H<sub>2</sub>S.

12. The process of claim 1, further comprising introducing at least a portion of said regenerated sorbent into said sorption zone, wherein said regenerated sorbent introduced into said sorption zone comprises a substitutional solid metal oxide solution characterized by the formula  $M_XZn_YO$ , wherein M is said promoter metal, wherein X and Y are in the range of from about 0.01 to about 0.99.

13. A process comprising:

(a) introducing a raw gas stream into a sorption zone, wherein said raw gas stream comprises in the range of from about 10 to about 75 volume percent carbon monoxide (CO), in the range of from about 8 to about 50 volume percent hydrogen (H<sub>2</sub>), in the range of from about 4 to about 40 volume percent water (H<sub>2</sub>O), and in the range of from about 0.001 to about 5 volume percent hydrogen sulfide (H<sub>2</sub>S);

(b) contacting at least a portion of said raw gas stream with an initial sorbent in said sorption zone to thereby produce a product gas stream and a sulfur-laden sorbent, wherein said initial sorbent comprises Zn and a promoter metal;

(c) drying at least a portion of said sulfur-laden sorbent to thereby produce a dried sulfur-laden sorbent; and

(d) regenerating at least a portion of said dried sulfur-laden sorbent in a regeneration zone under regeneration conditions to thereby produce a regenerated sorbent and an off-gas stream,

wherein said regenerated sorbent comprises less than about 20 weight percent of sorbent-damaging compounds formed during said regenerating of step (d).

14. The process of claim 13, wherein said sulfur-laden sorbent comprises in the range of from about 10 to about 20 weight percent sorbed sulfur, wherein said regenerating of step (d) removes at least 90 weight percent of said sorbed sulfur.

15. The process of claim 13, wherein said sorbent-damaging compounds include zinc oxysulfate and/or zinc silicate.

16. The process of claim 13, wherein said regenerating of step (d) is carried out with an initial temperature in the range of from about 250 to about 650°C, wherein said regenerating of step (d) further comprises increasing the temperature of said regeneration zone by at least 75°C above said initial temperature during a time period of less than about 24 hours.

17. The process of claim 13, wherein said regenerating of step (d) includes introducing a regeneration gas having an initial standard hourly space velocity (SGHSV) greater than  $1,000 \text{ h}^{-1}$  into said regeneration zone, wherein said regenerating of step (d) includes increasing the SGHSV of said regeneration gas by at least about  $1,000 \text{ h}^{-1}$ .

5

18. The process of claim 13, wherein said raw gas stream further comprises in the range of from about 100 to about 5,000 parts per million by volume (ppmv) of carbonyl sulfide (COS) and in the range of from about 50 to about 2,000 ppmv of hydrochloric acid (HCl), wherein said product gas stream comprises less than 20 ppmv of said HCl and/or said COS.

10

19. The process of claim 13, wherein said product gas comprises less than 50 ppmv of  $\text{H}_2\text{S}$ .

15

20. The process of claim 13, wherein said initial sorbent comprises a substitutional solid metal solution characterized by the formula  $\text{M}_A\text{Zn}_B$ , wherein M is said promoter metal, wherein A and B are in the range of from about 0.01 to about 0.99, wherein said promoter metal is nickel.

20

21. The process of claim 13, further comprising introducing at least a portion of said regenerated sorbent into said sorption zone, wherein said regenerated sorbent introduced into said sorption zone comprises a substitutional solid metal oxide solution characterized by the formula  $\text{M}_X\text{Zn}_Y\text{O}$ , wherein M is said promoter metal, wherein X and Y are in the range of from about 0.01 to about 0.99.

22. A process comprising:

- 5 (a) gasifying a carbon-containing material in a gasification zone to thereby produce a raw gas stream, wherein said raw gas stream comprises in the range of from about 10 to about 75 volume percent carbon monoxide (CO), in the range of from about 8 to about 50 volume percent hydrogen (H<sub>2</sub>), in the range of from about 4 to about 40 volume percent water (H<sub>2</sub>O), in the range of from about 0.001 to about 5 volume percent sulfur-containing compounds, and in the range of from about 50 to about 2,000 parts per million by volume (ppmv) of hydrochloric acid (HCl);
- 10 (b) introducing at least a portion of said raw gas stream into a sorption zone, wherein said sorption zone contains an initial sorbent, wherein said initial sorbent comprises Zn, expanded perlite, and a promoter metal, wherein at least a portion of said initial sorbent comprises a substitutional solid solution characterized by the formula  $M_ZZn_{(1-Z)}Al_2O_4$  and a substitutional solid metal solution characterized by the formula  $M_AZn_B$ , wherein M is a promoter metal component and A, B, and Z are in the range of from about 0.01 to about 0.99;
- 15 (c) sorbing at least a portion of said sulfur-containing compounds from said raw gas stream in said sorption zone with said initial sorbent to thereby produce a sulfur-laden sorbent and a product gas stream, wherein said sorbing is carried out at a temperature in the range of from about 225 to about 550°C and a pressure in the range of from about 250 to about 575 psig, wherein said sulfur-laden sorbent has a sulfur loading in the range of from about 1 to about 27 weight percent, wherein said product gas stream comprises less than 50 ppmv of sulfur-containing materials and less than 20 ppmv of HCl;
- 20 (d) drying at least a portion of said sulfur-laden sorbent in a drying zone to thereby produce a dried sulfur-laden sorbent;
- 25 (e) regenerating at least a portion of said dried sulfur-laden sorbent in a regeneration zone via contact with a regeneration gas under regeneration conditions to thereby produce a regenerated sorbent and a SO<sub>2</sub>-containing off-gas, wherein said regeneration gas has an initial standard gas hourly space velocity (SGHSV) in the range of from about 1,000 to about 80,000 h<sup>-1</sup>, wherein said regenerating is
- 30



carried out with an initial temperature in the range of from about 300 to about 600°C;

- 5 (f) returning at least a portion of said regenerated sorbent to said sorption zone, wherein said regenerated sorbent returned to said sorption zone comprises a substitutional solid metal oxide solution characterized by the formula  $M_XZn_YO$ , wherein M is a promoter metal component and X and Y are in the range of from about 0.01 to about 0.99, wherein said regenerated sorbent has a sulfur loading of less than 6 weight percent, wherein said regenerated sorbent comprises less than 20 weight percent of sorbent-damaging compounds created during said  
10 regenerating of step (e); and
- (g) routing at least a portion of said SO<sub>2</sub>-containing off-gas stream to a Claus unit.

23. The process of claim 22, wherein said regenerating of step (e) further comprises alternating between the sub-steps of:

15 (e1) increasing the temperature of said regeneration zone by a first incremental amount, wherein the magnitude of said first incremental amount is in the range of from 10 to 30 percent of said initial temperature; and

(e2) increasing the SGHSV of said regeneration gas by a second incremental amount, wherein the magnitude of said second incremental amount is in the range of from  
20 10 to 30 percent of said initial SGHSV,  
wherein steps (e1) and (e2) are carried out over a time period of less than 12.5 hours,

wherein said alternating between steps (e1) and (e2) is carried out until said off-gas stream comprises less than about 500 ppmv of sulfur dioxide.

25 24. The process of claim 22, wherein said promoter metal is nickel.

25. The process of claim 22, wherein the temperature of said sorption zone is within at least 200°C of the temperature of said raw gas stream exiting said gasification  
30 zone.

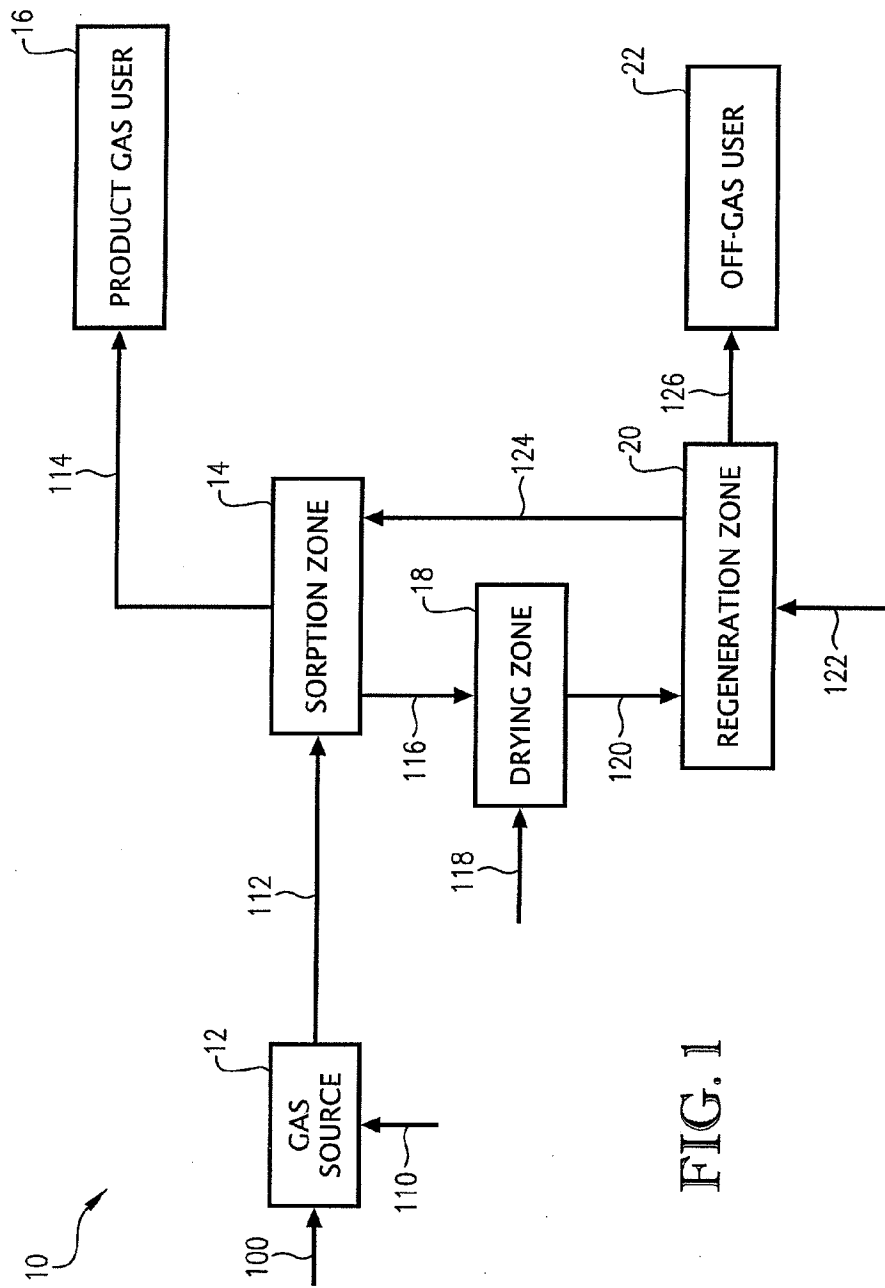

FIG. 1

## INTERNATIONAL SEARCH REPORT

International application No.  
**PCT/US2008/079321****A. CLASSIFICATION OF SUBJECT MATTER*****B01D 53/50(2006.01)i, B01D 50/00(2006.01)i, B01J 8/00(2006.01)i***

According to International Patent Classification (IPC) or to both national classification and IPC

**B. FIELDS SEARCHED**

Minimum documentation searched (classification system followed by classification symbols)

IPC 8: B01D, B01J

Documentation searched other than minimum documentation to the extent that such documents are included in the fields searched

Korean Utility models and applications for Utility Models since 1975

Electronic data base consulted during the international search (name of data base and, where practicable, search terms used)

eKIPASS(KIPO internal) "sulfur", "sorbent", "adsorbent", "regeneration", "zinc", "space velocity", "increasing", "step", "adjust", and similar terms

**C. DOCUMENTS CONSIDERED TO BE RELEVANT**

Category*	Citation of document, with indication, where appropriate, of the relevant passages	Relevant to claim No.
Y A	WO 03/053566 A1 (PHILLIPS PETROLEUM COMPANY) 3 July 2003 See the whole document.	13-15, 18-22, 24-25 1-12, 16, 17, 23
Y A	WO 2006/052997 A1 (TRUSTEES OF TUFTS COLLEGE) 18 May 2006 see abstract and claims 1-12.	13-15, 18-22, 24-25 1-12, 16, 17, 23
Y A	US 5366717 B2 (DORCHAK et al.) 22 November 1994 see column 4 lines 32 - 49 and column 6 line 12 - 22.	13-15, 18-22, 24-25 1-12, 16, 17, 23
A	WO 2005/058468 A2 (CONOCOPHILLIPS COMPANY) 30 June 2005 see the whole document.	1-25
A	US 5703003 A (SIRIWARDANE) 30 December 1997 see the whole document.	1-25

 Further documents are listed in the continuation of Box C. See patent family annex.

\* Special categories of cited documents:

"A" document defining the general state of the art which is not considered to be of particular relevance

"E" earlier application or patent but published on or after the international filing date

"L" document which may throw doubts on priority claim(s) or which is cited to establish the publication date of citation or other special reason (as specified)

"O" document referring to an oral disclosure, use, exhibition or other means

"P" document published prior to the international filing date but later than the priority date claimed

"T" later document published after the international filing date or priority date and not in conflict with the application but cited to understand the principle or theory underlying the invention

"X" document of particular relevance; the claimed invention cannot be considered novel or cannot be considered to involve an inventive step when the document is taken alone

"Y" document of particular relevance; the claimed invention cannot be considered to involve an inventive step when the document is combined with one or more other such documents, such combination being obvious to a person skilled in the art

"&amp;" document member of the same patent family

Date of the actual completion of the international search

29 APRIL 2009 (29.04.2009)

Date of mailing of the international search report

**30 APRIL 2009 (30.04.2009)**

Name and mailing address of the ISA/KR

Korean Intellectual Property Office  
Government Complex-Daejeon, 139 Seonsa-ro, Seo-  
gu, Daejeon 302-701, Republic of Korea

Facsimile No. 82-42-472-7140

Authorized officer

JANG, Sung Won

Telephone No. 82-42-481-8296



**INTERNATIONAL SEARCH REPORT**

Information on patent family members

International application No.

**PCT/US2008/079321**

Patent document cited in search report	Publication date	Patent family member(s)	Publication date
WO 03-053566 A1	03.07.2003	AU 2002-322119 A1 US 6635795	09.07.2003 21.10.2003
WO 2006-052997 A1	18.05.2006	AU 2005-304693 A1 CN 101098742 EP 1819420 A1 US 2008-0267848 A1	18.05.2006 02.01.2008 22.08.2007 30.10.2008
US 5366717	22.11.1994	US 5798088 US 5366717 A WO 91-04941 A1	25.08.1998 22.11.1994 18.04.1991
US 2004-0140244 A1	22.07.2004	WO 2005-058468 A2	30.06.2005
US 5703003	30.12.1997	CA 2145250 A1 CN 1111602 A DE 19510633 A1 ES 2116879 A1 FI 951344 A FR 2718658 A1 GB 2287714 A IT 1291950 B1 TO 950220 A1 JP 07-256093 NL 9500519 A US 5494880 US 5866503	24.09.1995 15.11.1995 28.09.1995 16.07.1998 24.09.1995 20.10.1995 27.09.1995 21.01.1999 25.09.1995 09.10.1995 01.11.1995 27.02.1996 02.02.1999