

Oct. 6, 1925.

1,556,020

J. J. NOLL

REMOVABLE CLOSURE FOR RECEPTACLES

Filed July 28, 1922

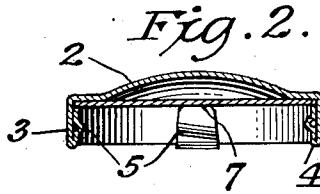
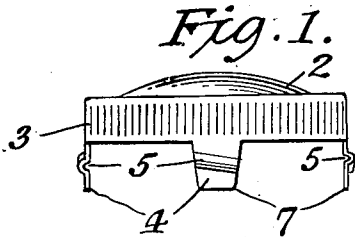

*Fig. 1a.*

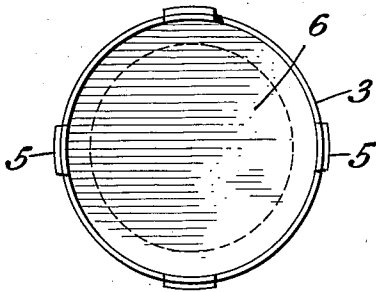

*Fig. 3.*

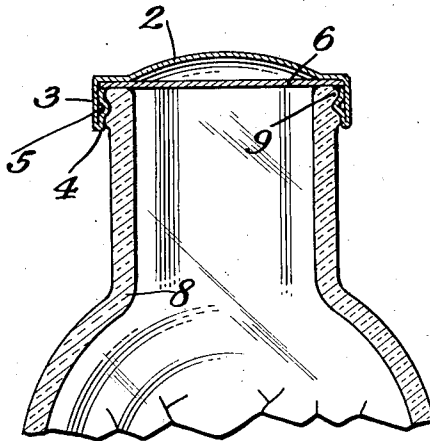

*Fig. 5.*

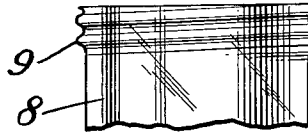
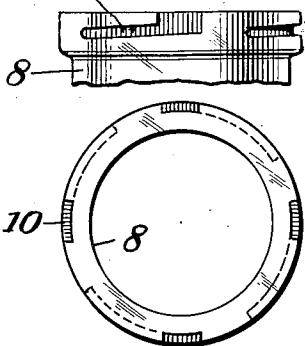

*Fig. 4.*

Inventor  
*John J. Noll*  
By his Attorney  
*Clarence D. Kerr*

# UNITED STATES PATENT OFFICE.

JOHN J. NOLL, OF WHEELING, WEST VIRGINIA, ASSIGNOR TO HAZEL-ATLAS GLASS COMPANY, OF WHEELING, WEST VIRGINIA, A CORPORATION OF WEST VIRGINIA.

## REMOVABLE CLOSURE FOR RECEPTACLES.

Application filed July 28, 1922. Serial No. 578,042.

*To all whom it may concern:*

Be it known that I, JOHN J. NOLL, a citizen of the United States, and a resident of Wheeling, Ohio County, West Virginia, have  
 5 invented new and useful Improvements in Removable Closures for Receptacles, of which the following is a specification, reference being had to the accompanying drawings, in which—

10 Fig. 1 is a perspective of a cap or closure embodying my invention, but showing the securing lugs before they are bent into final position; Fig. 1\* is a bottom plan of the cap shown in Fig. 1; Fig. 2 is a section of  
 15 a completed cap; Fig. 3 is a section showing the application of the cap to a glass jar; Fig. 4 is an elevation of the top of the jar showing the threads thereon; and Fig. 5 shows in elevation and plan, respectively,  
 20 the top of a receptacle with a bayonet slot for reception of the securing means on my improved cap.

My invention relates to closures or caps which have interiorly formed threads for  
 25 engagement with corresponding threads on the exterior of a receptacle, my invention comprises a closure or cap preferably formed from a unitary metal shell in which portions of the shell are bent inwardly to form on  
 30 the inside thereof a series of threads intended to engage continuous threads, quick threads and jump threads or lugs formed around the top or neck of a glass jar or other receptacle. My invention also comprises the various features which I shall  
 35 hereinafter describe and claim.

Referring to the drawings, the closure or cap is preferably formed from a single piece of metal having an uninterrupted top 2 and  
 40 a depending annular flange 3. Attached to the flange 3 are a plurality of projections 4 which, as is shown in Fig. 1, are formed with ribs or threads 5, and are bent in the position shown in Figs. 2 and 3, in which the  
 45 inwardly and upwardly bent ends 7 of the projections 4 serve to hold the liner 6 in operative position in the cap.

When the caps are applied to a bottle or jar 8, as is shown in Fig. 3, the ribs 5, which  
 50 are diagonal in shape, grasp the threads 9 tightly and thereby hold the cap securely in position. Further, the projections 4 as

formed constitute spring pieces which accommodate themselves to variations in sizes of bottles or jars, and of the threads thereon, as they maintain a spring pressure  
 55 against the threads 9 and thereby always provide a close fit.

In Fig. 5 I have shown a modified form of my invention in which the jar 8 is provided with threads 10 in the form of a bayonet slot, into which the ribs 5 of the cap may be inserted, and rotation of the cap through  
 60 an angle of about 45 degrees will lock the cover securely thereon.

My improved construction is of advantage in permitting ready application of the caps to the receptacles, in insuring quick and positive locking of the caps, in providing for variations in sizes of threads and  
 70 sizes of the receptacles, and in preventing liners from falling out of the caps before application of the caps to receptacles.

The terms and expressions which I have employed are used as terms of description  
 75 and not of limitation, and I have no intention, in the use of such terms and expressions of excluding any mechanical equivalents of the features shown and described, or portions thereof, but recognize that various  
 80 structural modifications are possible within the scope of the invention claimed, it being understood that by the term "threads" I refer to continuous threads, quick threads, and various forms of interrupted threads.

What I claim is:

1. A closure for receptacles comprising a metal cap having an uninterrupted top surface and a depending annular flange, projections on the lower edge of said flange arranged to be bent inwardly and upwardly  
 90 against the interior of said flange, and ribs on said projections forming threads for engaging resiliently threads on the receptacle, the projections having bearings against the  
 95 inner face of said flange above and below said ribs whereby the said projections and ribs are held tightly against the threads of the receptacle by said flange.

2. A closure for receptacles comprising a  
 100 metal cap having an uninterrupted top surface and a depending annular flange, projections on the lower edge of said flange arranged to be bent inwardly and upwardly

against the interior of said flange, ribs on the receptacle by said flange, and a liner  
said projections forming threads for engag- supported inside said cap by the said pro- 10  
ing resiliently threads on the receptacle, the jections in substantially the position oc-  
projections having bearings against the in- cupied when the cap is applied to a recepta-  
5 ner face of said flange above and below cle.  
said ribs whereby the said projections and  
ribs are held tightly against the threads of

JOHN J. NOLL.