

R. WHITEHILL.

BOBBIN-WINDERS FOR SEWING-MACHINES.

No. 184,937.

Patented Nov. 28, 1876.

Fig. 1.

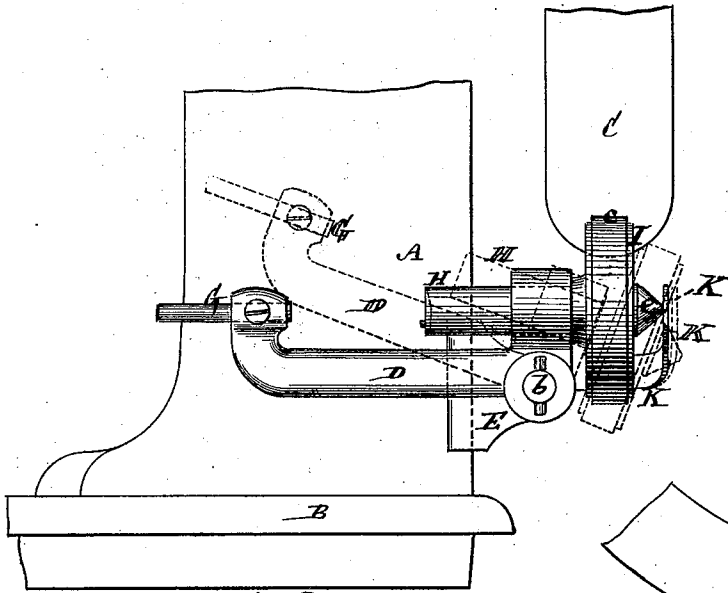

Fig. 2.

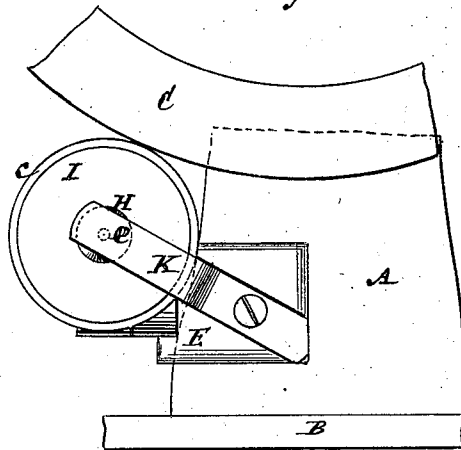
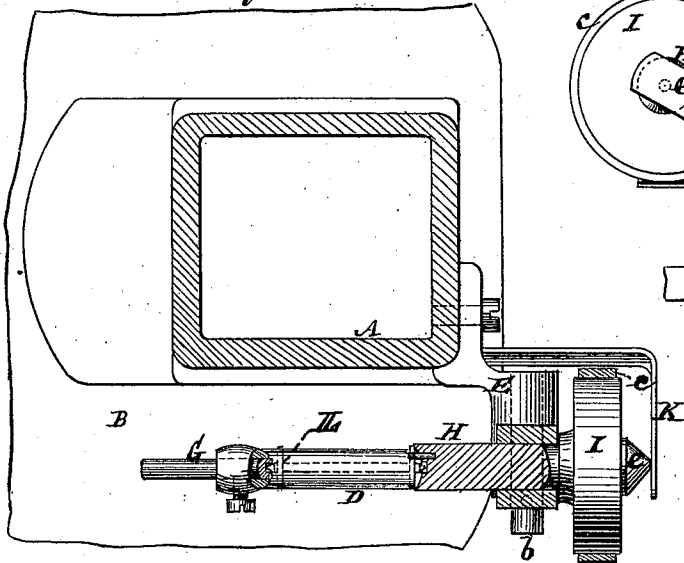

Fig. 3.



Witnesses
John Recker
Fred. Hayes

Robert Whitehill.
by his Attorneys
J. Brown & Allen

UNITED STATES PATENT OFFICE.

ROBERT WHITEHILL, OF NEW YORK, N. Y.

IMPROVEMENT IN BOBBIN-WINDERS FOR SEWING-MACHINES.

Specification forming part of Letters Patent No. **154,937**, dated November 28, 1876; application filed April 24, 1876.

To all whom it may concern:

Be it known that I, ROBERT WHITEHILL, of the city, county, and State of New York, have invented certain new and useful Improvements in Bobbin-Winders for Sewing-Machines; and I do hereby declare that the following is a full, clear, and exact description of the same, reference being had to the accompanying drawing, which forms part of this specification.

This invention relates to shuttle-bobbin winders for sewing-machines in which the winder is provided with a wheel that is brought into contact with the fly or driving wheel of the machine to effect the winding, and is released from said contact after the required amount of thread has been wound upon the bobbin.

The invention consists in a bobbin-winder of this description that is swiveled or rocked to bring its wheel in contact with and release it from action by the operating-wheel of the machine, and in which the construction is such that both the bobbin and the winding-spindle work between two centers, subject to an easy axial spring pressure or hold, and in which the same spring not only serves to thus hold the bobbin and winding-spindle, but also to keep the winder in position when its wheel is brought in contact with the operating-wheel of the machine, and to provide for its release from such contact when required.

A bobbin-winder thus constructed, while it affords every facility for a rapid connection and disconnection of it with and from the operating-wheel of the machine, and for the insertion and removal of the bobbin, has an easy or free running action, which not only reduces "bearing" friction, but avoids any liability of the slipping of the winder on the wheel which operates it.

In the accompanying drawing, Figure 1 represents a side view of a bobbin-winder constructed in accordance with the invention, and as applied to a sewing-machine, here shown only in part. Fig. 2 is a rear-end view of the same, and Fig. 3 a partly-sectional horizontal view thereof.

A is the frame of a sewing-machine or rear base portion of the goose-neck thereof, and B its cloth table or bed. C is the fly, or it may be the driving-wheel, of the machine. D is the arm or frame of the shuttle-bobbin winder, hung to rock on a pivot, *b*, of a bracket, E, which is secured to the rear base

portion of the goose-neck A. This arm or frame D is provided, at its one end, with a female bobbin-center, G, and with a longitudinally sliding or adjustable winding and bobbin-driving spindle, H, at its opposite end. I is the wheel on the winding-spindle H, by which winding motion is communicated to the latter by friction, through contact with the fly-wheel C, when the winder is swiveled on its pivot *b* to the position shown for it by full lines in Fig. 1. The same view shows, by dotted lines, the position of the parts when the winder is swiveled on its pivot *b* to release its wheel I from driving contact with the wheel C. Said wheel I is covered with a rubber band, *c*, or otherwise clothed or formed to establish the necessary driving friction when said wheel is brought in contact with the fly-wheel C.

K is a bent sheet-metal spring, fastened at its rear end to the frame of the machine, or bracket E attached thereto, and bearing at its outer and free end on a back center, *e*, of the winding-spindle H.

This spring serves several functions. Thus it serves to give an elastic axial pressure or hold of the shuttle-bobbin L (shown by dotted lines in Fig. 3) between the center G and winding-spindle H, and an inward axial pressure on the center *e* of said spindle, thus causing the bobbin and winding-spindle to work between two centers. Said spring K also serves to hold the winder in position when it is swung on its pivot *b* to bring the wheel I into working contact with the wheel C, as shown by full lines in Figs. 1, 2, and 3. It also serves to provide for the retention of the winder, and for the ready insertion and removal of the bobbin, when the winder is swiveled on its pivot *b*, as shown by dotted lines in Fig. 1, to put its wheel I out of contact with the operating-wheel C, and the center *e* of the longitudinally-movable winding-spindle is released from contact with or brought under the spring K.

I claim—

The combination of the spring K with the back center *e* of the longitudinally-free winding-spindle H, the wheel I on said spindle, the rocking or swinging bobbin-winder frame D, and the center G, essentially as herein set forth.

Witnesses: ROBERT WHITEHILL.
MICHAEL RYAN,
FRED. HAYNES.