



US 20070272109A1

(19) **United States**

(12) **Patent Application Publication**
Heinke et al.

(10) **Pub. No.: US 2007/0272109 A1**

(43) **Pub. Date: Nov. 29, 2007**

(54) **BLASTING**

Publication Classification

(76) Inventors: **Nils Alberto Heinke**, Elkins, WV (US);
Roger Dean Skaggs, Bonne Terre, MO
(US); **Stephen Mitchell Collinsworth**,
Stanton, KY (US)

(51) **Int. Cl.**
F42D 1/08 (2006.01)
(52) **U.S. Cl.** **102/312**

Correspondence Address:
COZEN O'CONNOR, P.C.
1900 MARKET STREET
PHILADELPHIA, PA 19380 (US)

(57) **ABSTRACT**

(21) Appl. No.: **10/574,377**

(22) PCT Filed: **Sep. 30, 2004**

(86) PCT No.: **PCT/IB04/03196**

§ 371(c)(1),
(2), (4) Date: **Apr. 30, 2006**

(30) **Foreign Application Priority Data**

Oct. 3, 2003 (ZA)..... 2003/7748

In blasting rock, a drill hole (12) is charged with spaced, composite layers (20), (30, 40) at different levels between an open mouth (14) and a blind bottom (16). Each composite layer is supported on a plug (22, 32, 42). Flowable plunger material (24, 34, 44), e.g. drill cuttings, is supported on the respective plug followed by blast material (26, 36, 46), topped by a further layer of plunger material (28, 38, 48). The plunger material (48) at the top, is in the form of tamping. The composite layers are spaced respectively from one another and optionally, from the bottom (16). Initiators (27, 37, 47) can be actuated by means of a controller to initiate the blasting material to displace the layers of plunger material at speed to collide, e.g. with the bottom and with one another to concentrate energy at the collision sites.

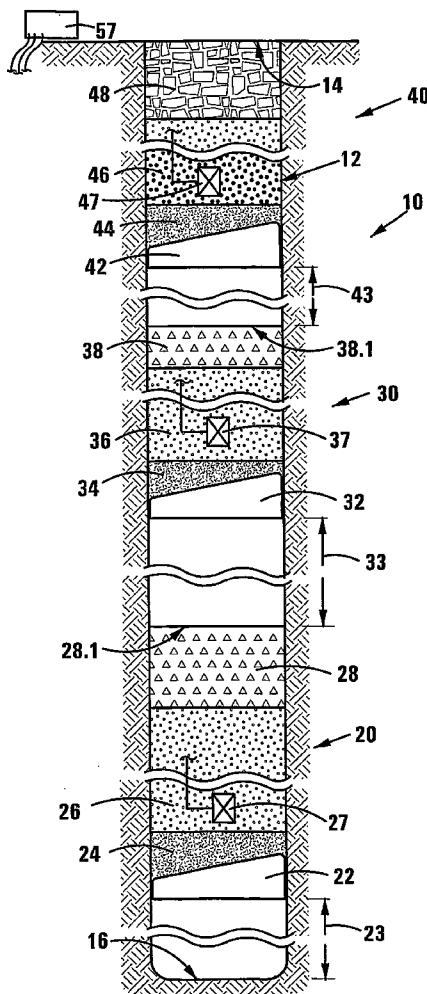

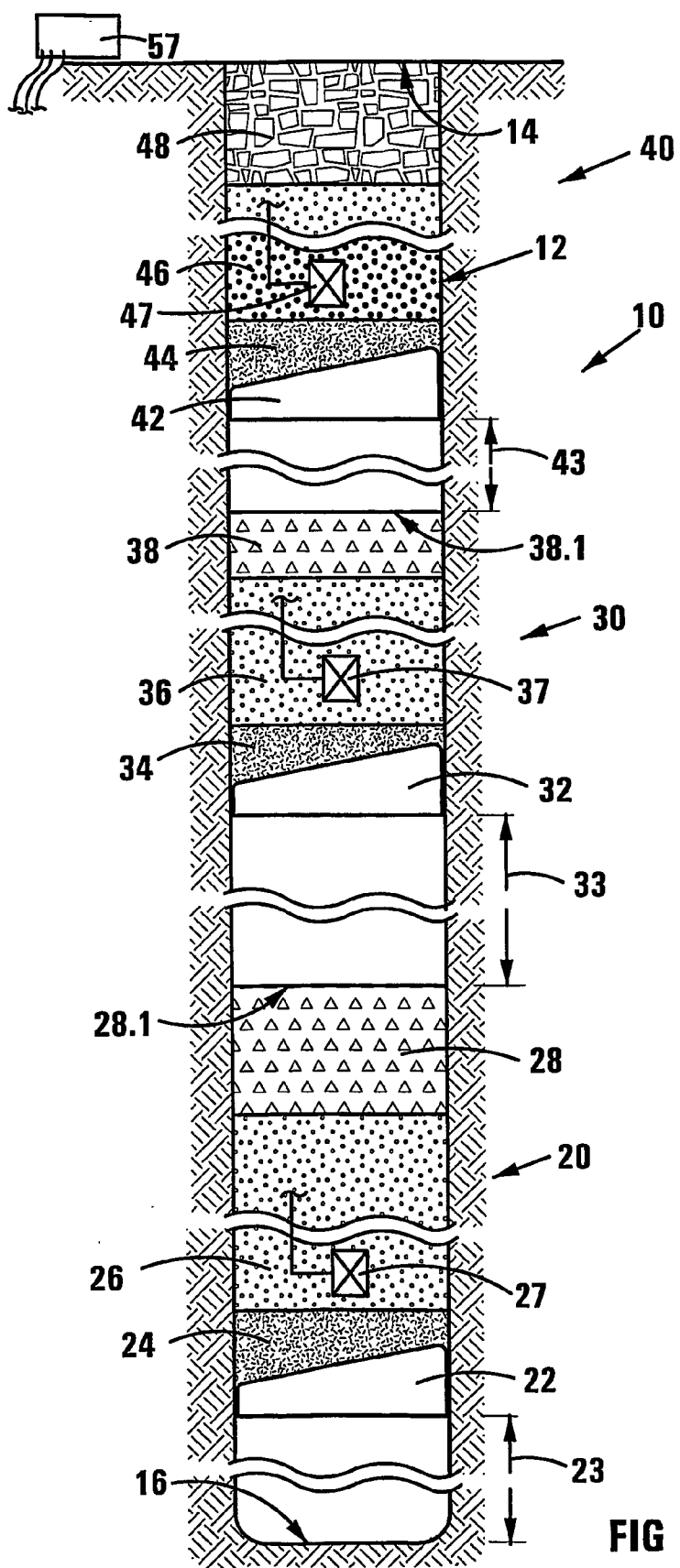

FIG 1

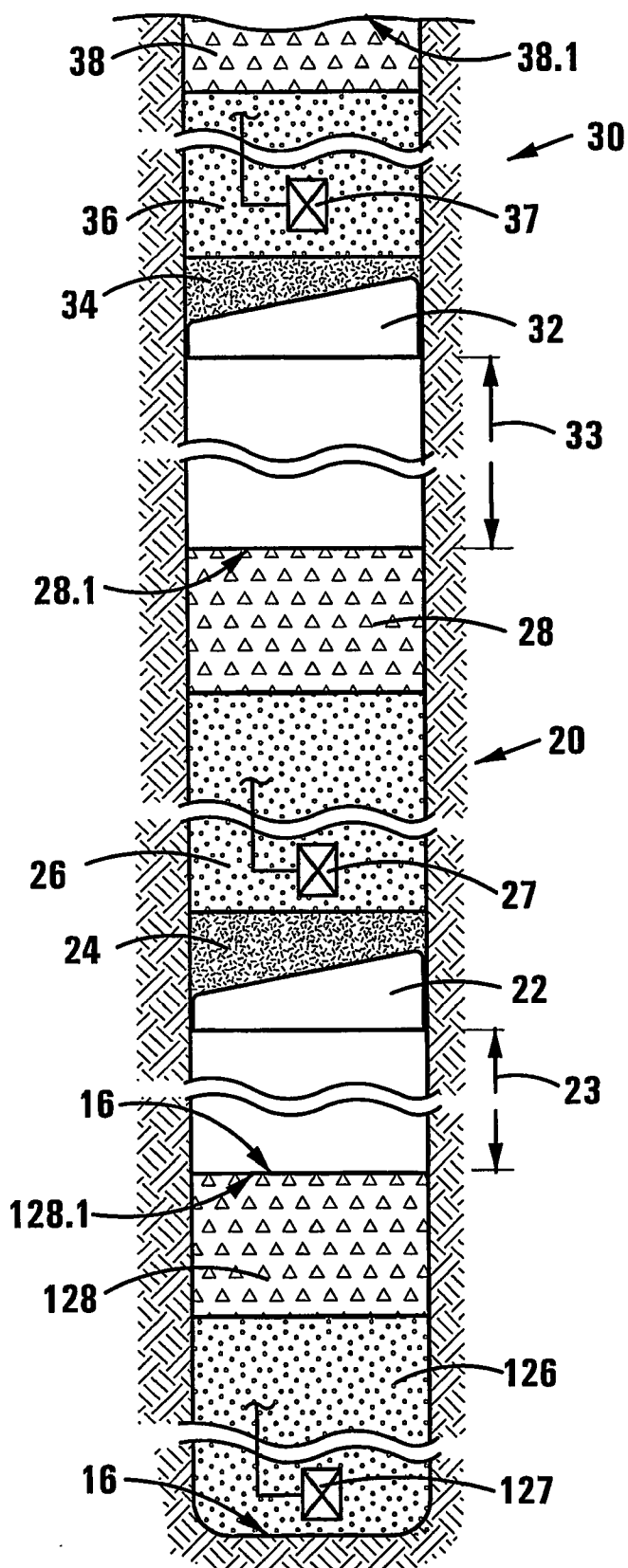

FIG 2

BLASTING

[0001] THIS INVENTION relates to blasting. It relates more specifically to blasting of rock or other material by means of a blasting substance charged into a drill hole extending into the rock or other material to be blasted.

[0002] For purposes of this invention, the term “blasting” is to be interpreted widely to cover, generally, destruction of rock or other material by means of pressure generating or shock wave generating substances such as explosives, propellants, or the like. Likewise, the term “blasting substance” is to be interpreted to cover explosives, propellants and other pressure or shock wave generating substances.

[0003] In accordance with a first aspect of this invention, there is provided a method of charging a drill hole extending between a mouth thereof at a surface, and a blind end or bottom thereof remote from the mouth, the method including

[0004] providing in the drill hole at a relatively low level toward said bottom a lower layer of a blasting substance, and a lower layer of a plunger material proximately above the lower layer of blasting substance;

[0005] providing in the drill hole at a relatively high level remote from said bottom a higher layer of a plunger material, spaced a predetermined distance above said lower layer of plunger material, and proximately above said higher layer of plunger material, a higher layer of a blasting substance;

[0006] placing initiators in association with the respective layers of blasting substances and connecting the initiators to a controller for actuating the initiators at predetermined time intervals.

[0007] The spacing between opposing surfaces of respectively said lower layer and said higher layer of plunger material may be of the same order of magnitude, i.e. between about 0.5 m and about 3 m.

[0008] The respective layers of plunger material may be flowable material allowing placement in the drill hole at the respective desired positions. Drill cuttings are a preferred plunger material.

[0009] Said relatively low level may be spatially adjacent a bottom of the drill hole and spaced above the bottom by a predetermined distance. The spacing may be between about 0.5 m and about 3 m, advantageously between about 1 m and about 2 m, preferably about 1.5 m, but depending on several factors, such as the depth of the drill hole, the nature of the rock or other material to be blasted, the nature of the plunger material, the nature of the blasting substance, and the like.

[0010] The method may include supporting in each respective case the layer of plunger material and the layer of blasting substance on a plug capable of being positioned in the drill hole at a predetermined level.

[0011] By way of development, preferably, the method may include providing plunger material below the lower layer of blasting substance to provide a lower composite layer, providing plunger material above the higher layer of blasting substance to provide a higher composite layer, and providing one or more further composite layers of blasting substance and plunger material in the drill hole, with spac-

ings in-between, in series along the drill hole. Further, preferably, the method may include tamping the drill hole proximate its mouth.

[0012] In a variant method, the lower layer of blasting substance may be positioned proximate and may be supported on the bottom of the drill hole.

[0013] In accordance with a second aspect of this invention, there is provided a method of blasting a drill hole charged in accordance with the first aspect of this invention, the method including actuating the initiators by means of the controller. The initiators may be actuated simultaneously. They may be actuated electrically or electronically. Instead, they may be actuated pyrotechnically.

[0014] The invention extends in accordance with a third aspect to a method of mining including blasting an array of drill holes, each in accordance with the second aspect of this invention.

[0015] The invention extends in accordance with a fourth aspect to a charged drill hole extending between a mouth thereof at a surface, and a blind end or bottom thereof remote from the mouth, including

[0016] a lower layer of a blasting substance at a relatively high level toward said bottom, and a lower layer of a plunger material proximately above the lower layer of blasting substance;

[0017] a higher layer of a plunger material at a relatively high level remote from said bottom, and spaced a predetermined distance above said lower layer of plunger material, and proximately above said higher layer of plunger material, a higher layer of a blasting substance;

[0018] initiators placed in association with the respective layers of blasting substances and having connectors for connection to a controller for actuating the initiators at predetermined time intervals.

[0019] Thus, generally, the drill hole is charged in accordance with the first aspect of this invention.

[0020] The spacing between opposing surfaces of respectively said lower layer and said higher layer of plunger material may be between about 0.5 m and about 3 m.

[0021] The respective layers of plunger material may be flowable material allowing placement in the drill hole at the respective desired positions. The plunger material may be drill cuttings.

[0022] Said relatively low level may be spatially adjacent a bottom of the drill hole and spaced above the bottom by a predetermined distance. The spacing may be between about 0.5 m and about 3 m, with the preferred range and value, and provisos mentioned above.

[0023] In a preferred embodiment, in each respective case or in each respective series, the layer of plunger material and the layer of blasting substance may be supported on a plug positioned in the drill hole at a predetermined level.

[0024] By way of preferred development, the charged drill hole may include plunger material provided below the lower layer of blasting substance to form a lower composite layer, plunger material provided above the higher layer of blasting substance to form a higher composite layer, and one or more

further composite layers of blasting substance and plunger material, with spacings in-between, in series along the drill hole.

[0025] The charged drill hole may include tamping material closing the drill hole proximate its mouth.

[0026] In accordance with a fifth aspect of the invention, there is provided a blasting operation including an array of blast holes each in accordance with the fourth aspect.

[0027] The initiators may be connected to a common control.

[0028] The invention is now described by way of example with reference to the accompanying diagrammatic drawings, which show, in sectional views, respectively a charged drill hole in accordance with the invention, and, truncated, a variant embodiment thereof.

[0029] With reference to FIG. 1 of the drawings, a charged drill hole in accordance with the invention is generally indicated by reference numeral 10.

[0030] A drill hole, indicated by reference numeral 12, extends along material, such as rock, to be blasted. The drill hole 12 has an open mouth 14 at a surface of the material to be blasted, and a blind end or blind bottom remote from the mouth and indicated by reference numeral 16. For convenience of terminology (e.g. higher/lower, above/below, and the like), it is assumed that the drill hole is a vertical drill hole extending from the mouth 14 downwardly to the bottom.

[0031] However other orientations, such as drill holes extending obliquely downwardly, are also covered mutandis mutandis as falling within the scope of this invention.

[0032] The charged drill hole 10 comprises a lower composite layer generally indicated by reference numeral 20. The position of the lower composite layer 20 is determined by means of a plug 22 which is lodged at a predetermined position in the drill hole 12. The plug 22 is a sacrificial plug and may be any plug suitable for this purpose.

[0033] In the embodiment illustrated in FIG. 1, the lower composite layer 20, and more specifically the plug 22, is at a predetermined spacing, generally indicated by reference numeral 23, above the bottom 16. In this embodiment, the spacing 23 is about 1.5 m.

[0034] The lower composite layer 20 extends from the position of the plug 22 upwardly. Immediately above the plug 22, supported by, and partially contained within, the plug 22, is provided a layer 24 of plunger material in the form of drill cuttings. The layer 24, including a portion of the layer 24 contained within the plug 22, is of the order of 150 mm length or thickness, in this embodiment. The reason for selecting the term "plunger material" for the layer 24 and its mechanism of operation, will be described herein below.

[0035] Immediately above the layer 24, there is provided a layer 26 of an explosive which, in this embodiment, is of the order of 9 m long.

[0036] Immediately above the layer 26 of explosive, there is provided a further layer of plunger material generally indicated by reference numeral 28. The plunger material 28, in this embodiment, is of the order of about 0.6 m thick or long and it has an upper, free surface 28.1.

[0037] At a relatively higher level remote from the bottom, there is provided a higher composite layer generally indicated by reference numeral 30. The higher composite layer 30 is of generally similar construction and composition to the lower composite layer 20. Furthermore, the higher composite layer 30 is spaced at a predetermined spacing 33 above the upper free surface 28.1 in a manner similar to spacing of the lower composite layer 20 above the bottom 16. For convenience, similar reference numerals have been used for the respective layers or components and they are not again described. The length of the layer 36 of explosive, for the higher composite layer, is of the order of about 6 m.

[0038] The general arrangement may be repeated as many times as required, depending also on the depth of the drill hole. Generally, all of the composite layers have a more or less central charge of explosives flanked above and below by a layer of plunger material and each composite layer is based or supported on a plug 22, 23, or the like.

[0039] Toward the top of the drill hole 12, there is provided a plug 42 supporting a layer of plunger material in the form of drill cuttings indicated by reference numeral 44 and having thereabove a charge of explosives 46. Above the charge of explosives 46, tamping material, for example in the form of hard rock, drill cuttings, or the like is provided indicated by reference numeral 48, and which extends generally to the mouth 14.

[0040] In each of the layers of explosives, there is provided one or more initiators 27, 37, 47 for actuating the explosives. In this embodiment, the initiators are electric or electronic and are controlled by means of a controller 57. In another embodiment or application, the initiators may be pyrotechnic.

[0041] The Applicant does not wish to be bound by theory, but an explanation of the Applicant's hypothesis of the mechanism of operation when the explosives are actuated, is expected to assist a reader's understanding of the invention.

[0042] Generally, the Applicant expects that it would wish the explosives to be actuated generally simultaneously, but this is not at this stage regarded as of particular importance, and further tests, also depending on various factors, may indicate that time lags may be advantageous.

[0043] The general hypothesis is based on two aspects. First, it is believed that actuation of an explosive would propel the adjacent material, i.e. the plunger material, in the nature of a plunger away from the centre of actuation i.e. along a respective spacing, 23, 33, 43, or the like, bearing in mind that such spacing would generally offer the route of least resistance. It is expected that at least the spacings remote from the bottom 16 would consist of air, whereas the spacing 23 adjacent the bottom may consist of air, or water in the case of wet holes, or partially water and partially air.

[0044] The second aspect is that the plunger propelled by actuation of the explosive will necessarily impinge on an obstacle and will come to a sudden halt. For example, the layer of plunger material 24 will impinge and come to a halt when it hits the bottom 16, and in the case of the plunger material 28 propelled upwardly when the layer of explosive 26 is actuated, and the plunger material 34 which will be propelled downwardly when the explosive 36 is actuated, they will impinge upon each other to cause the sudden halt.

[0045] It is to be appreciated that propelling of the plunger material converts the chemical or potential energy, associated with actuation of the explosive, into or partially into kinetic energy in that the respective layers or masses of plunger material are propelled at high speed. Initial calculations indicate that very high amounts of kinetic energy are involved.

[0046] Thus, when the carrier of the kinetic energy (i.e. the mass proceeding at high speed) is forced to a sudden halt, the kinetic energy is again converted into energy associated with pressure or shock wave which causes very effective destruction of rock or other surrounding material, in accordance with preliminary tests conducted by the Applicant.

[0047] The Applicant believes that this invention has the possibility of greatly reducing the amount of explosives required to conduct blasting operations. This will have the direct effect of a commensurate cost saving in respect of explosives, which makes out a high percentage of the total cost of blasting. It is further expected to have the subsidiary advantages, which may be very important in some applications, of focussing or concentrating the destructive effort intermediate the bottom 16 of the drill hole and the mouth 14 of the drill hole thus limiting or virtually totally obviating unrequired and sometimes undesired destruction of rock below the bottom 16. Furthermore, it limits and possibly virtually obviates transfer of energy above the level of the mouth, for example limiting or obviating fly rock, and other undesirable side effects of blasting.

[0048] With reference to FIG. 2, in a variation of the embodiment of FIG. 1, an explosive substance 126 is positioned proximate the bottom 16 to be supported on the bottom 16. Immediately above the layer 126 of explosive substance, there is provided a layer 128 of a plunger material, conveniently in the form of drill cuttings, and forming a free upper surface 128.1. An initiator 127 is provided with the explosive substance 126 and is connected to a controller such as the controller 57. Spaced above the free upper surface 128.1 (i.e. with an air space in between) there is provided one or more composite layers 20, 30 and the like as described with reference to FIG. 1.

1. A method of charging and blasting a drill hole extending between a mouth thereof at a surface, and a blind end or bottom thereof remote from the mouth, the method comprising:

- charging the drill hole which comprises
 - providing in the drill hole at a relatively low level toward said bottom a lower layer of a blasting substance, and a lower layer of a plunger material proximately above the lower layer of blasting substance;
 - providing in the drill hole at a relatively high level remote from said bottom a higher layer of a plunger material, spaced a predetermined distance above said lower layer of plunger material to form a spacing, and proximately above said higher layer of plunger material, a higher layer of a blasting substance;
 - placing initiators in association with the respective layers of blasting substances and connecting the initiators to a controller for actuating the initiators at predetermined time interval; and

blasting the charged drill hole which comprises

actuating the initiators by means of the controller, thereby propelling the lower layer of plunger material by means of the lower layer of blasting substance into said spacing, and propelling the higher layer of plunger material by means of the higher layer of blasting substance into said spacing thereby causing the lower layer of plunger material and the higher layer of plunger material to impinge upon each other, and causing conversion of kinetic energy associated with the propelled layers of plunger material into pressure or shock waves to effect destruction of rock in the surrounding material.

2. A method as claimed in claim 1, in which the spacing between opposing surfaces of respectively said lower layer of plunger material and said higher layer of plunger material is between about 0.5 m and about 3 m.

3. A method as claimed in claim 1 in which the respective layers of plunger material are flowable material allowing placement in the drill hole at the respective desired positions.

4. A method as claims in claim 1, further comprising tamping the drill hole proximate its mouth.

5. A method as claimed in claim 1 in which said relatively lower level is spatially adjacent the bottom of the drill hole end spaced above the bottom by a predetermined distance.

6. A method as claimed in claim 5 in which the spacing between said relatively low level and the bottom is between about 0.5 m and about 3 m.

7. A method as claimed in claim 5, wherein said charging step further comprises supporting in each respective case the layer of plunger material and the layer of blasting substance on a plug capable of being positioned in the drill hole at a predetermined level.

8. A method as claims in claim 5, wherein said charging step further comprises providing plunger material below the lower layer of blasting substance to provide a lower composite layer, providing plunger material above the higher layer of blasting substance to provide a higher composite layer, and providing one or more further composite layers of blasting substance and plunger material in the drill hole, with spacings in-between, in series along the drill hole.

9. A method as claimed in claim 1, in which the lower layer of blasting substance is positioned proximate and is supported on the bottom of the drill hole.

10. A method as claimed in claim 1 wherein said actuating step further comprises actuating the initiators at time intervals to initiate the respective blasting substances simultaneously.

11. A method as claimed in claim 10 wherein said actuating step further comprises actuating the initiators in a way selected from electrically, electronically, or pyrotechnically.

12. A method of mining comprising carrying out the method of claim 1 on each of an array of drill holes.

13. A charged drill hole extending between a mouth thereof at a surface, and a blind end or bottom thereof remote from the mouth, comprising within the drill hole,

- a lower layer of a blasting substance at a relatively low level toward said bottom, and a lower layer of plunger material proximately above the lower layer of blasting substance,

a higher layer of plunger material at a relatively high level remote from said bottom, and spaced a predetermined distance above said lower layer of plunger material such as to form a spacing therebetween, and proximately above said higher layer of plunger material, a higher layer of a blasting substance;

initiators placed in association with the respectively layers of blasting substances and having connectors for connection to a controller for actuating the initiators at predetermined time intervals,

wherein the lower and higher layers of plunger material oppose each other spatially, each layer of plunger material being backed by a layer of blasting substance, such that, in use, on actuation of the layers of blasting substance the layers of plunger material are propelled toward each other, to impinge upon each other and to convert kinetic energy associated with the propelled layers of plunger material into pressure or shock waves to destruct surrounding material.

14. A charged drill hole as claimed in claim 13 in which the spacing between opposing surfaces of respectively said lower layer and said higher layer of plunger material is between about 0.5 m and about 3 m.

15. A charged drill hole as claimed in claim 13 in which the respective layers of plunger material are flowable material allowing placement in the drill hole at the respective desired positions.

16. A charged drill holes as claimed in claim 13, further comprising tamping material closing the drill hole proximate its mouth.

17. A charged drill hole as claimed in claim 13 in which said relatively low level is spatially adjacent a bottom of the drill hole and spaced above the bottom by a predetermined distance.

18. A charged drill hole as claimed in claim 17 in which the spacing is between about 0.5 m and about 3 m.

19. A charged drill hole as claimed in claim 17 in which in each respective case, the layer of plunger material and the layer of blasting substance is supported on a plug positioned in the drill hole at a predetermined level.

20. A charged drill hole as claimed in claim 17, further comprising plunger material provided below the lower layer of blasting substance to form a lower composite layer, plunger material provided above the higher layer of blasting substance to form a higher composite layer, and one or more further composite layers of blasting substance and plunger material, with spacings in-between, in series along the drill hole.

21. A charged drill hole as claimed in claim 13, in which the lower layer of blasting substance in proximate the bottom and is supported on the bottom.

22. A blasting operation comprising an array of blast holes each in accordance with claim 13.

* * * * *