



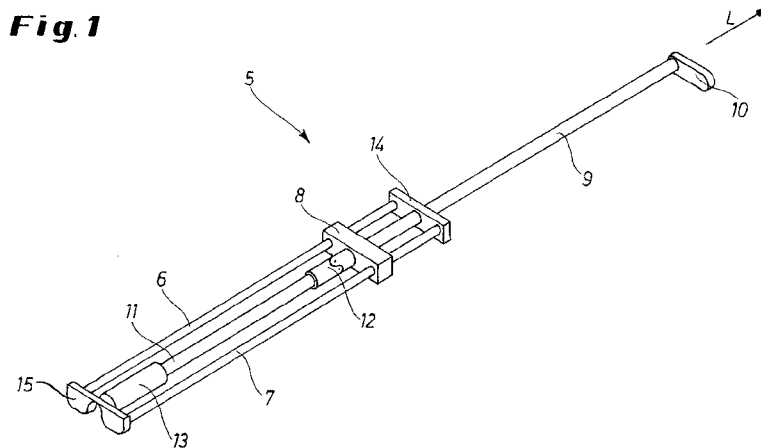
- (51) International Patent Classification:  
*B64D 11/00* (2006.01) *B64D 11/04* (2006.01)
- (21) International Application Number:  
PCT/EP2015/069827
- (22) International Filing Date:  
31 August 2015 (31.08.2015)
- (25) Filing Language: English
- (26) Publication Language: English
- (30) Priority Data:  
62/046,390 5 September 2014 (05.09.2014) US
- (71) Applicant: SELL GMBH [DE/DE]; Dr.-Siegfried-Straße,  
35745 Herborn (DE).
- (72) Inventors: WALLBOTT, Tim Tobias; Mühlweg 27,  
35633 Lahnau (DE). KLASSEN, Samuel; Haigerer Straße  
25, 35708 Haiger (DE).
- (74) Agent: GROSSE, Wolf-Dietrich; Gihске Große Klüppel  
Kross, Bürogemeinschaft von Patentanwälten, Hammer-  
straße 3, 57072 Siegen (DE).

- (81) Designated States (unless otherwise indicated, for every kind of national protection available): AE, AG, AL, AM, AO, AT, AU, AZ, BA, BB, BG, BH, BN, BR, BW, BY, BZ, CA, CH, CL, CN, CO, CR, CU, CZ, DE, DK, DM, DO, DZ, EC, EE, EG, ES, FI, GB, GD, GE, GH, GM, GT, HN, HR, HU, ID, IL, IN, IR, IS, JP, KE, KG, KN, KP, KR, KZ, LA, LC, LK, LR, LS, LU, LY, MA, MD, ME, MG, MK, MN, MW, MX, MY, MZ, NA, NG, NI, NO, NZ, OM, PA, PE, PG, PH, PL, PT, QA, RO, RS, RU, RW, SA, SC, SD, SE, SG, SK, SL, SM, ST, SV, SY, TH, TJ, TM, TN, TR, TT, TZ, UA, UG, US, UZ, VC, VN, ZA, ZM, ZW.
- (84) Designated States (unless otherwise indicated, for every kind of regional protection available): ARIPO (BW, GH, GM, KE, LR, LS, MW, MZ, NA, RW, SD, SL, ST, SZ, TZ, UG, ZM, ZW), Eurasian (AM, AZ, BY, KG, KZ, RU, TJ, TM), European (AL, AT, BE, BG, CH, CY, CZ, DE, DK, EE, ES, FI, FR, GB, GR, HR, HU, IE, IS, IT, LT, LU, LV, MC, MK, MT, NL, NO, PL, PT, RO, RS, SE, SI, SK, SM, TR), OAPI (BF, BJ, CF, CG, CI, CM, GA, GN, GQ, GW, KM, ML, MR, NE, SN, TD, TG).

Published:

— with international search report (Art. 21(3))

(54) Title: TROLLEY ARRANGEMENT OF A GALLEY OF A VEHICLE, ESPECIALLY OF AN AIRCRAFT



(57) Abstract: The invention relates to a trolley arrangement (1) of a galley of a vehicle, especially of an aircraft, wherein the trolley arrangement (1) comprises a trolley container (2) in which at least two trolleys (3, 4) can be arranged along a longitudinal direction (L), wherein the trolley arrangement (1) furthermore comprises a trolley handling device (5) for pulling and pushing a trolley (3, 4) into the trolley container (2) in the longitudinal direction (L). To facilitate the handling of the trolleys when storing them in the trolley container and taking them out of the same the invention is characterized in that the trolley handling device (5) comprises a linear guide (6, 7, 8) with at least one stationary guiding bar (6, 7) and a slide (8) which is movable along the at least one guiding bar (6, 7) in longitudinal direction (L), a pulling and pushing bar (9) which is axially fixed at the slide (8) but which can rotate around its axis which is oriented in longitudinal direction (L), wherein at least one hook (10) is arranged at the distal end of the pulling and pushing bar (9) which is remote from the slide (8), and a handling bar (11) which is axially fixed at the slide (8) or at the pulling and pushing bar (9), wherein a joint (12) is arranged between the handling bar (11) and the slide (8) or the pulling and pushing bar (9), so that the handling bar (11) and the pulling and pushing bar (9) are axially connected and are rotationally coupled.

WO 2016/034531 A1

## **Trolley Arrangement of a Galley of a Vehicle, especially of an Aircraft**

The invention relates to a trolley arrangement of a galley of a vehicle, especially of an aircraft, wherein the trolley arrangement comprises a trolley container in which at least two trolleys can be arranged along a longitudinal direction, wherein the trolley arrangement furthermore comprises a trolley handling device for pulling and pushing a trolley into the trolley container in the longitudinal direction.

A generic trolley arrangement is known from **WO 2014/125046 A1**. Here, trolleys can be pulled out of a trolley container, wherein (at least) two trolleys are arranged one after another in longitudinal direction. The handling device is here a simple rod with a hook at its end for pulling the rear trolley out of the container. Problems occur when the used trolleys have to be pushed into the container again. The pre-known device is not suitable to securely push in all trolleys into the trolley container. Thus, with pre-known trolley arrangement it is possible to pull out trolleys from the trolley container; but it is not possible to securely push back trolleys into the container again after use.

Thus, it is an object of the present invention to further develop a trolley arrangement of the generic kind which allows to facilitate the handling of the trolleys when storing them in the trolley container and taking them out of the same.

The solution of this object by the invention is characterized in that the trolley handling device comprises

- a linear guide with at least one stationary guiding bar and a slide which is movable along the at least one guiding bar in longitudinal direction,
- a pulling and pushing bar which is axially fixed at the slide but which can rotate around its axis which is oriented in longitudinal direction, wherein at least one hook is arranged at the distal end of the pulling and pushing bar which is remote from the slide, and
- a handling bar which is axially fixed at the slide or at the pulling and pushing bar, wherein a joint is arranged between the handling bar and the slide or the pulling and pushing bar, so that the handling bar and the pulling and pushing bar are axially connected and are rotationally coupled.

The joint is preferably a cardan joint. In general each type of joint can be employed, e. g. a ball joint, a universal joint, a spring joint.

The joint can have a stop which limits the angle between the pulling and pushing bar and the handling bar.

The trolley handling device is preferably arranged in the upper region of the trolley container at its inner side.

A handling grip can be arranged at the distal end of the handling bar which is remote from the slide. Thereby, it is possible that the handling grip is arranged at the same height as at least one locking bolt which is arranged at a galley front for locking of the trolleys in the trolley container.

The trolley handling device can furthermore comprise two stops which limit the movement of the slide in longitudinal direction.

According to a possible embodiment a single hook can be arranged at the distal end of the pulling and pushing bar.

Alternatively, two hooks can be arranged at the distal end of the pulling and pushing bar. In this case it can be provided that the two hooks are arranged preferably parallel to another at a defined distance.

At least one of the hooks can be arranged at the pulling and pushing bar by means of a hinge-joint. The hinge-joint can thereby comprise a spring element which biases the hook against a stop.

A further embodiment of the invention proposes that a further hook is arranged at the pulling and pushing bar adjacent to the joint. This allows a further improved handling of trolleys.

The linear guide has preferably two stationary guiding bars which are arranged parallel to another and extend in longitudinal direction.

Thus, the arm-like trolley handling device allows pulling out and pushing in of a trolley into the trolley container especially in the galley of an aircraft. By the proposed device the trolleys can easily be reached even if they are in the rear part or position in the trolley container. It is not necessary that a user must grab deeply below the working area of the galley (on top of the trolley container) to reach all trolleys in the container. So, the device according to the invention increases the comfort of use and allows a quick and easy pulling out and pushing in of a trolley during flight. For example, by the proposed arrangement two full-size trolley (at least 1.5 trolleys) can be parked one after another.

Beneficially, the proposed trolley handling device allows an easy extraction and retraction of the trolley from the trolley container and into the same.

For each trolley row (if there are several side by side) one trolley handling device can be arranged.

Also it is beneficial that the proposed trolley handling device can easily withstand inflight loads as defined by the authorities and the OEM specification.

In the drawings embodiments of the invention are shown.

Fig. 1 shows a perspective view of a trolley handling device in an extended position,

Fig. 2 shows a perspective view of the trolley handling device in a retracted position,

Fig. 3 shows a perspective view of two trolleys which are arranged in a trolley container,

Fig. 4 shows a side view of two trolleys which are arranged in the trolley container,

Fig. 5 shows a perspective view of the trolley handling device in an alternative embodiment,

Fig. 6a shows a side view of two trolleys which are arranged in the trolley container,

Fig. 6b shows a side view of the container at a later stage during taking out the trolleys from the trolley container,

Fig. 6c shows a side view of the trolley container at a later stage as in Fig. 6b,

Fig. 6d shows a side view of the trolley container at a later stage as in Fig. 6c,

Fig. 7 shows a side view of a trolley which is arranged in the trolley container,

Fig. 8 shows a side view of the end of the pulling and pushing bar of the trolley handling device with two hooks at a distal end,

- Fig. 9 shows a side view of the end of the pulling and pushing bar of the trolley handling device with one hinged hook at a distal end,
- Fig. 10 shows a perspective view of an end of the handling bar with a handling grip according to a first embodiment of the grip,
- Fig. 11 shows a perspective view of an end of the handling bar with a handling grip according to a second embodiment of the grip,
- Fig. 12 shows a perspective view of an end of the handling bar with a handling grip according to a third embodiment of the grip,
- Fig. 13a shows a side view of the trolley container with a trolley in it with a trolley handling device according to another embodiment of the invention during taking out of the trolley from the container,
- Fig. 13b shows a side view of the trolley container at a later stage during taking out of the trolley from the container,
- Fig. 13c shows a side view of the trolley container at a later stage as in Fig. 13b,

Fig. 13d shows a side view of the trolley container at a later stage as in Fig. 13c,

Fig. 13e shows a side view of the trolley container at a later stage as in Fig. 13d,

Fig. 14 shows a side view of the trolley container with two trolleys in it a stored position,

Fig. 15 shows a side view of the trolley handling device according to an alternative embodiment,

Fig. 16 shows a cross section perpendicular to the longitudinal direction through the trolley handling device,

Fig. 17 shows a cross section perpendicular to the longitudinal direction through the trolley handling device according to a further alternative embodiment of the invention in a first position,

Fig. 18 shows the cross section perpendicular to the longitudinal direction through the trolley handling device according to the further alternative embodiment of the invention in a second position and

Fig. 19 shows a perspective view of a galley which is arranged in an aircraft, wherein a trolley arrangement according to the invention is depicted.

In the below figures a trolley arrangement 1 of a galley of an aircraft are shown and described. The arrangement comprises a trolley container 2 in which two trolleys can be arranged one after another. At the bottom side of the top plate of the trolley container 2 a trolley handling device 5 is arranged which allows an easy pulling out and pushing in of the trolleys 3, 4 from and into the trolley container 2. During handling of the trolleys 3, 4 the same are moved into a longitudinal direction L.

In figures 1 and 2 the trolley handling device 5 is shown in an extended position and in a retracted position.

The trolley handling device 5 has a linear guide 6, 7, 8 which comprises two guiding bars 6 and 7 which are stationary mounted in the trolley container. On the guiding bars 6, 7 a slide 8 is arranged which can move in longitudinal direction L. Two stops 14 and 15 limit the movement of the slide 8.

A pulling and pushing bar 9 is axially fixed at the slide 8 but it can rotate around its axis which is oriented in longitudinal direction L. A hook 10 is arranged at the distal end of the pulling and pushing bar 9 which is remote from the slide 8.

Furthermore, a handling bar 11 is arranged which is axially fixed at the slide 8 (alternatively at the pulling and pushing bar 9). A joint 12 being a cardan joint is arranged between the handling bar 11 and the slide 8 (or alternatively the pulling and pushing bar 9), so that the handling bar 11 and the pulling and pushing bar 9 are axially connected and are rotationally coupled; this means a rotation of the handling bar 11 is transferred to the pulling and pushing bar 9. The end of the handling bar 11 is equipped with a handling grip 13.

Thus, by rotating of the handling grip 13 around the axis of the handling bar 11 (which is identical with the longitudinal direction L in figures 2 and 3) also the pulling and pushing bar 9 is rotated and also the hook 10 rotates from the position as shown in figure 2 to the position as shown in figures 3 and vice versa. That is, the hook 10 can be brought into engagement with a trolley to pull it out of the trolley container 2 and push it back into the same.

The stop 14 is arranged in such a manner that a rotational movement of the pulling and pushing bar 9 allows a proper engagement of the hook 10 into the trolley 3 when the slide 8 reaches this stop 14.

Due to the joint 12 the handling bar 11 can be angled as far as necessary to allow an easy handling of the trolley handling device 5.

The trolley handling device 5 is arranged above the trolleys 3, 4 in the trolley container 2. This is shown in figure 3 and figure 4.

In figure 5 an alternative design of the trolley handling device 5 is shown. Here, the distal end of the pulling and pushing bar 9 is equipped with two hooks 10 which are arranged in a distance a. Also the handling grip 13 is here designed in another manner.

The operation of the trolley handling device 5 is depicted in figures 6a to 6d. If the trolleys 3, 4 have to be taken out from the trolley container 2 at first the front trolley 3 is taken out conventionally by hand, see figure 6a. Then, the rear trolley 4 has to be pulled out of the trolley container 2 by use of the trolley handling device 5. This is shown in the figures 6b to 6d.

By a rotational movement of the handling bar 11 – using the handling grip 13 – the hook 10 is engaged into the trolley 4, see figure 6b. Then the trolley 4 is pulled out by pulling the handling grip 13. The joint 12 allows an easy handling due to the possibility to swivel the handling bar 11 into a convenient position for use.

The trolley 4 can then be easily pulled out of the container 2 in a conventional way.

If the trolley handling device 5 is no longer necessary (see figures 6c and 6d) the hook 10 can be rotated back out of engagement with the trolley 4 and the device 5 can be brought back into the non-use position (see figure 6d).

Inserting of a trolley 4 into the container 2 takes place accordingly by carrying out the steps in the reverse order.

The joint 12 is used to absorb vertical forces which can be created during operation. So, the handling bar 11 remains movable and it is prevented that the mechanism is exposed to too high loads (transverse to the longitudinal direction). This is also beneficial for the user because he or she can hold the handling grip according to the body height conveniently in the right height.

Furthermore, it is possible to provide a stop for the swivel angle of the handling bar in the joint 12, so that a maximum angle is defined. Alternatively a joint with a predetermined angle can be employed, see figure 7.

In distinction to pre-known devices with flexible pulling rods the proposed trolley handling device 5 allows not only the application of pulling forces but also of pushing forces which allow a proper insertion of the trolley into the trolley container.

For the design of the hook 10 different embodiments are suggested. The hook 10 is responsible for engaging with the trolley to be pulled out or pushed into the container.

To hold the trolleys secure during all flight conditions it is preferred that the pulling and pushing bar 9 is equipped with two hooks 10 as shown in figure 8. The two hooks 10 are arranged parallel and at a defined distance  $a$ . The hooks 10 surround the trolley grip. So, the trolley is secured in both moving directions and cannot roll out from the container unintentionally.

In figure 9 another embodiment is shown. Here the hook or the hooks 10 are equipped with a hinge joint 16 which is supplied with a spring (not depicted) which biases the hook 10 in the position which is shown in figure 9 with full lines; the deflected position is shown with broken lines. So the hook 10 latches automatically into the trolley grip (at least in one moving direction).

In figures 10, 11 and 12 different designs of the handling grip 13 are shown. The handling grip 13 is the actuation element of the trolley handling device 5.

A first embodiment according to figure 10 has a cylindrical rotational body which is arranged coaxially to the handling bar 11. Here, the handling grip is not in the movement space of the trolleys in any status of the movement of the same. To recognize the position of the handling bar 11 and thus of the hook(s) 10 a visual mark can be provided at the handling grip 13.

Further embodiments are shown in figures 11 and 12 where the handling grip 13 is L-shaped or T-shaped. Here, the ergonomics are improved because the actuation forces are reduced. Also, the position of the handling bar 11 and thus of the hook(s) can be seen directly.

In figure 13a to 13e a further embodiment of the invention is shown which comes up with a further hook 17.

Here it is provided that an additional hook 17 is arranged adjacent to the joint 12 that is approximately in the position of a half-size trolley. With the above described solution a trolley 4 can be taken out of the container 2 only until a certain position. With the equipment of the further hook 17 it becomes possible to pull out a trolley more convenient. With the additional hook 17 it becomes possible to extract a trolley further until the front of the container 2 by a second movement of the trolley handling device and the handling bar 11 respectively and using the hook 17. So the comfort of handling is further improved. The user has not to grip into the container 2 to pull out a trolley completely.

This is depicted by the subsequent figures 13a to 13e.

A securing element for the trolleys acting in longitudinal direction can be relinquished by the further embodiment according to figure 14. Here, the hooks 10 are designed in such a manner that the outer dimension between the two hooks corresponds to the distance of the trolleys 3, 4 in the resting position. So the resting position is defined when the trolley handling device 5 is in the position as shown in figure 14. Thus, the hooks 10 are located in the resting position as shown; this position is thereby secured. So, an additional securing element can be avoided.

The beneficial placement of the trolley handling device 5 in the trolley container 2 is shown in figures 15 and 16. Here, the linear guide is integrated in the bottom

side of the cover of the trolley container 2 and above the trolleys. By doing so, weight can be saved. Thus, in this case the guiding bar (only one in this case) is established by the cover of the trolley container itself.

An alternative design of this concept is shown in figures 17 and 18.

So, a light-weight device is available which allows an easy handling of the trolleys 3, 4 during their movement into and out of the trolley container.

In Fig. 19 again a trolley arrangement 1 of a galley of an aircraft is shown. The arrangement comprises the trolley container 2 in which again two trolleys 3, 4 (trolley 4 cannot be seen) can be arranged one after another. At the bottom side of the top plate of the trolley container 2 the trolley handling device 5 (only the handling grip 13 can be seen) is arranged which allows the easy pulling out and pushing in of the trolleys 3, 4 from and into the trolley container 2. During handling of the trolleys 3, 4 the same are moved into a longitudinal direction L. The trolley handling device 5 is shown in the stored position and can be reached from the galley front 18.

As can also be seen in Fig. 19 locking bolts 19 for locking of the trolleys are arranged. The handling grips 13 as well as the locking bolts 19 are arranged on the same height and can be easily seen by the cabin crew.

By the proposed design it is possible to pull out trolleys from the rearmost position of the container in a convenient manner, i. e. without grabbing deep into the container.

The joint 12 allows that pressure forces can be transferred for pushing a trolley into the container. Also by use of the joint it is avoided that vertical and lateral forces coming from the user or resulting from the flight can damage the device.

The proposed device is useful for the aircrew as well as for ground staff during loading of aircraft galleys in the case of trolley containers which contain more than 1.5 trolleys one after the other.

**List of References:**

1	Trolley arrangement
2	Trolley container
3	Trolley
4	Trolley
5	Trolley handling device
6, 7, 8	Linear guide
6	Guiding bar
7	Guiding bar
8	Slide
9	Pulling and pushing bar
10	Hook
11	Handling bar
12	Joint
13	Handling grip
14	Stop
15	Stop
16	Hinge-joint
17	Hook
18	Galley front
19	Locking bolt
L	Longitudinal direction
a	Distance

**Patent Claims:**

1. Trolley arrangement (1) of a galley of a vehicle, especially of an aircraft, wherein the trolley arrangement (1) comprises a trolley container (2) in which at least two trolleys (3, 4) can be arranged along a longitudinal direction (L), wherein the trolley arrangement (1) furthermore comprises a trolley handling device (5) for pulling and pushing a trolley (3, 4) into the trolley container (2) in the longitudinal direction (L),

**characterized in that**

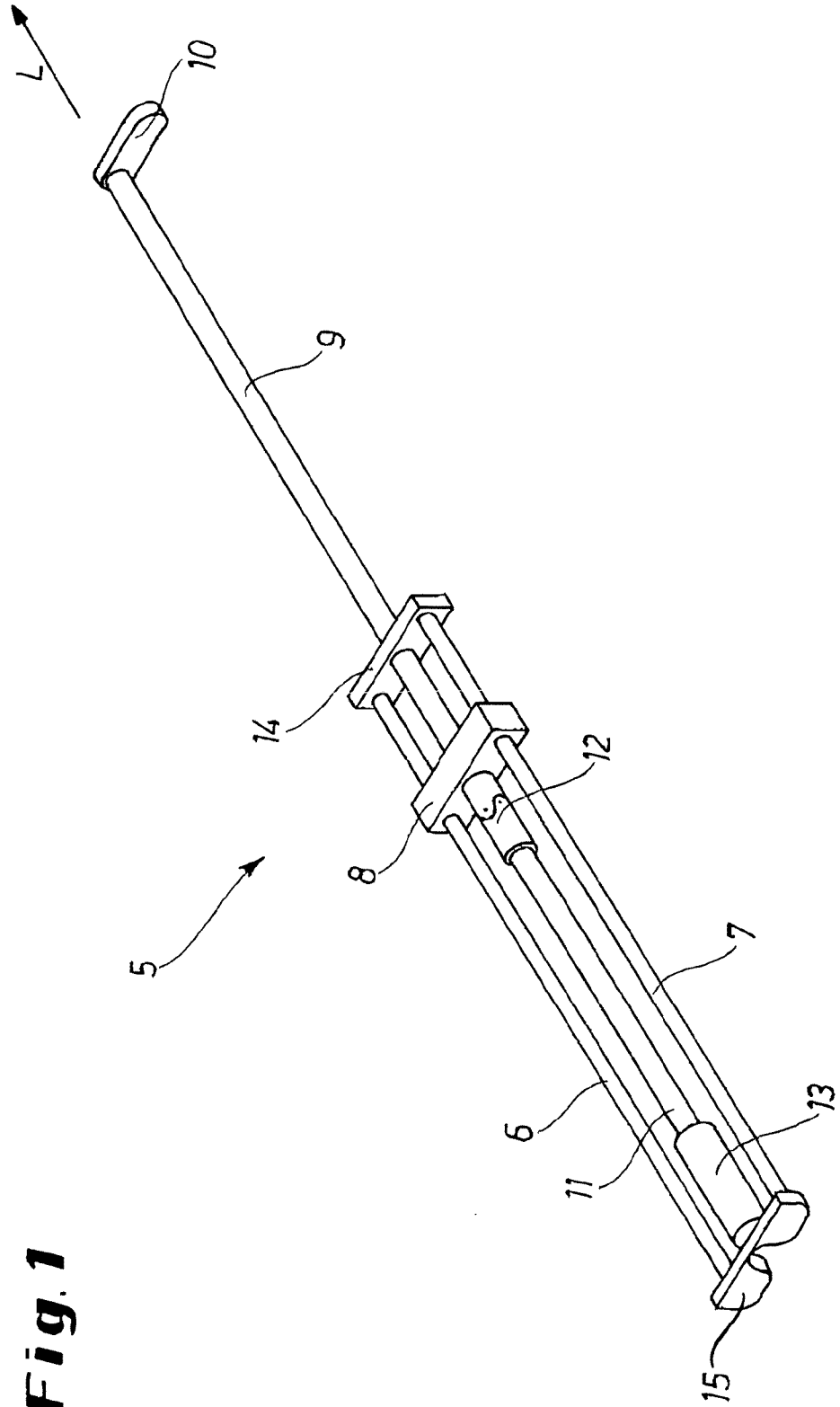
the trolley handling device (5) comprises

- a linear guide (6, 7, 8) with at least one stationary guiding bar (6, 7) and a slide (8) which is movable along the at least one guiding bar (6, 7) in longitudinal direction (L),
- a pulling and pushing bar (9) which is axially fixed at the slide (8) but which can rotate around its axis which is oriented in longitudinal direction (L), wherein at least one hook (10) is arranged at the distal end of the pulling and pushing bar (9) which is remote from the slide (8),
- a handling bar (11) which is axially fixed at the slide (8) or at the pulling and pushing bar (9), wherein a joint (12) is arranged between the handling bar (11) and the slide (8) or the pulling and pushing bar (9), so that the handling bar (11) and the pulling and pushing bar (9) are axially connected and are rotationally coupled.

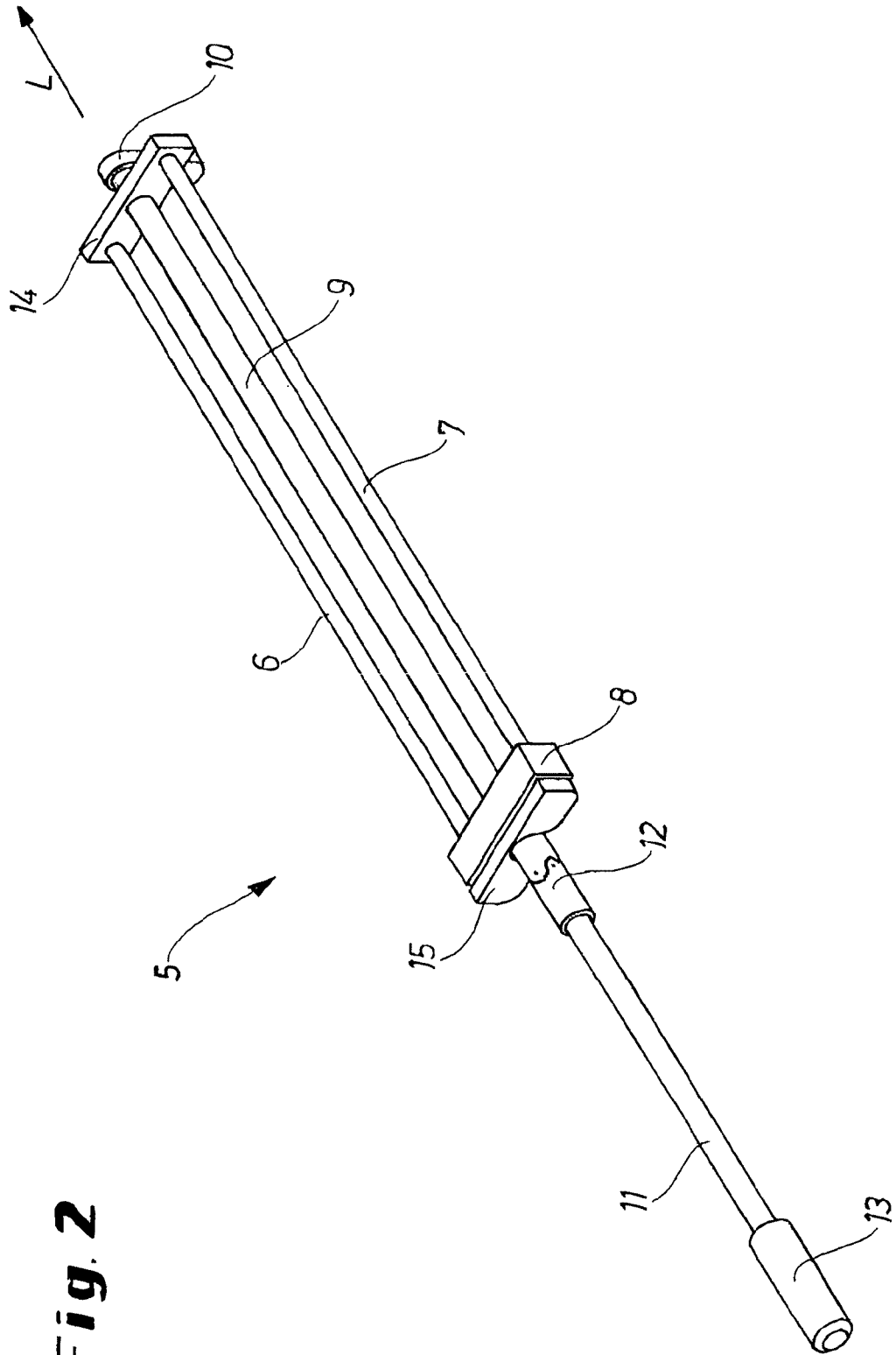
2. Trolley arrangement according to claim 1, characterized in that the joint (12) is a cardan joint.
3. Trolley arrangement according to claim 1 or 2, characterized in that the joint (12) has a stop which limits the angle between the pulling and pushing bar (9) and the handling bar (11).
4. Trolley arrangement according to one of claims 1 to 3, characterized in that the trolley handling device (5) is arranged in the upper region of the trolley container (2) at its inner side.
5. Trolley arrangement according to one of claims 1 to 4, characterized in that a handling grip (13) is arranged at the distal end of the handling bar (11) which is remote from the slide (8).
6. Trolley arrangement according to claim 5, characterized in that the handling grip (13) is arranged at the same height as at least one locking bolt (19) which is arranged at a galley front (18) for locking of the trolleys (3, 4) in the trolley container (2).
7. Trolley arrangement according to one of claims 1 to 6, characterized in that the trolley handling device (5) furthermore comprises two stops (14, 15) which limit the movement of the slide (8) in longitudinal direction (L).

8. Trolley arrangement according to one of claims 1 to 7, characterized in that a single hook (10) is arranged at the distal end of the pulling and pushing bar (9).
9. Trolley arrangement according to one of claims 1 to 7, characterized in that two hooks (10) are arranged at the distal end of the pulling and pushing bar (9).
10. Trolley arrangement according to claim 9, characterized in that two hooks (10) are arranged preferably parallel to another at a defined distance (a).
11. Trolley arrangement according to one of claims 1 to 10, characterized in that at least one of the hooks (10) is arranged at the pulling and pushing bar (9) by means of a hinge-joint (16).
12. Trolley arrangement according to claim 11, characterized in that the hinge-joint (16) comprises a spring element which biases the hook (10) against a stop.
13. Trolley arrangement according to one of claims 1 to 12, characterized in that a further hook (17) is arranged at the pulling and pushing bar (9) adjacent to the joint (12).

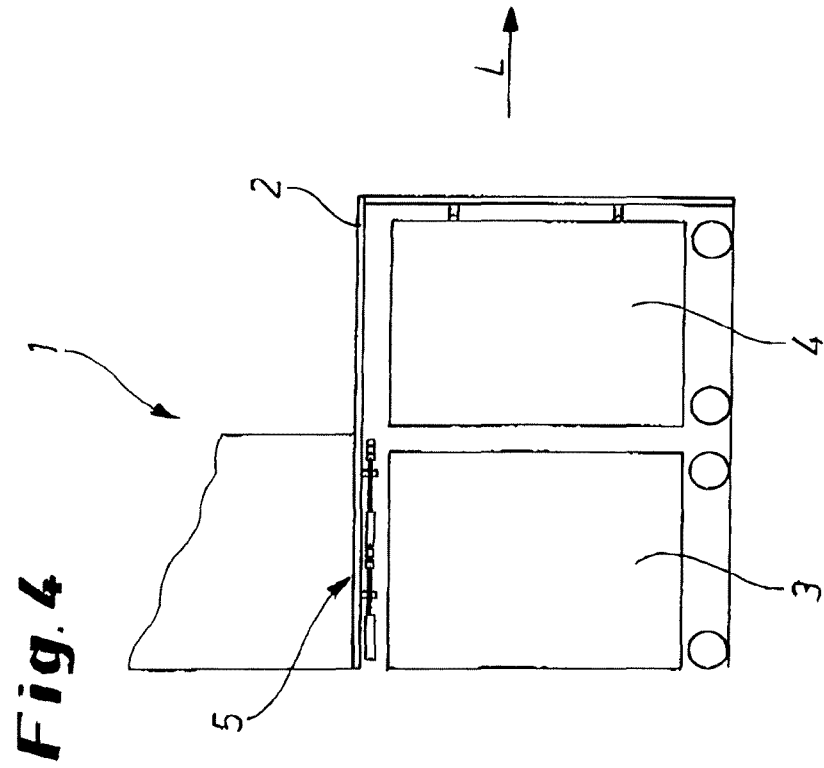
14. Trolley arrangement according to one of claims 1 to 13, characterized in that the linear guide (6, 7, 8) has two stationary guiding bars (6, 7) which are arranged parallel to another and extend in longitudinal direction (L).



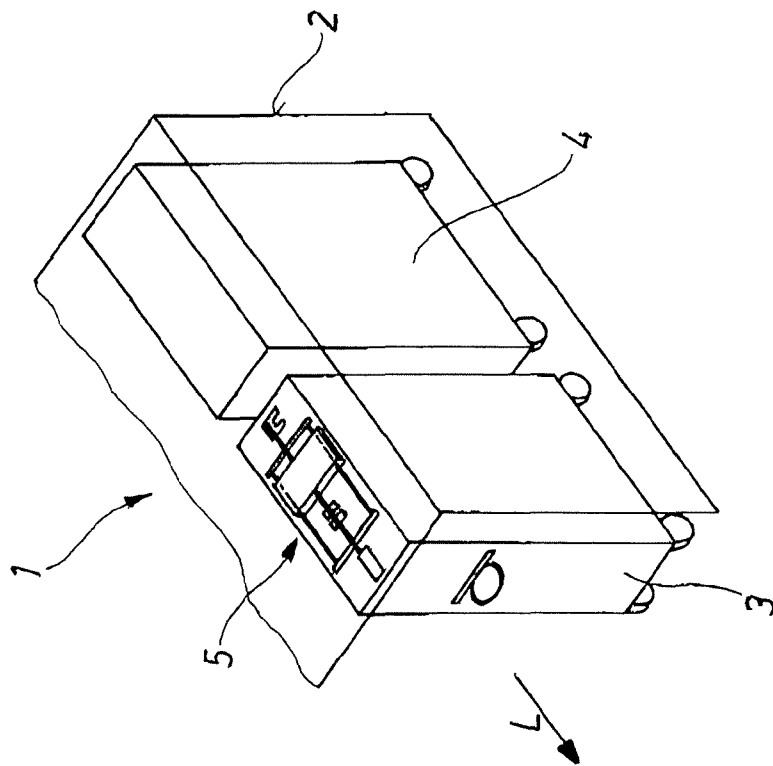
**Fig. 1**



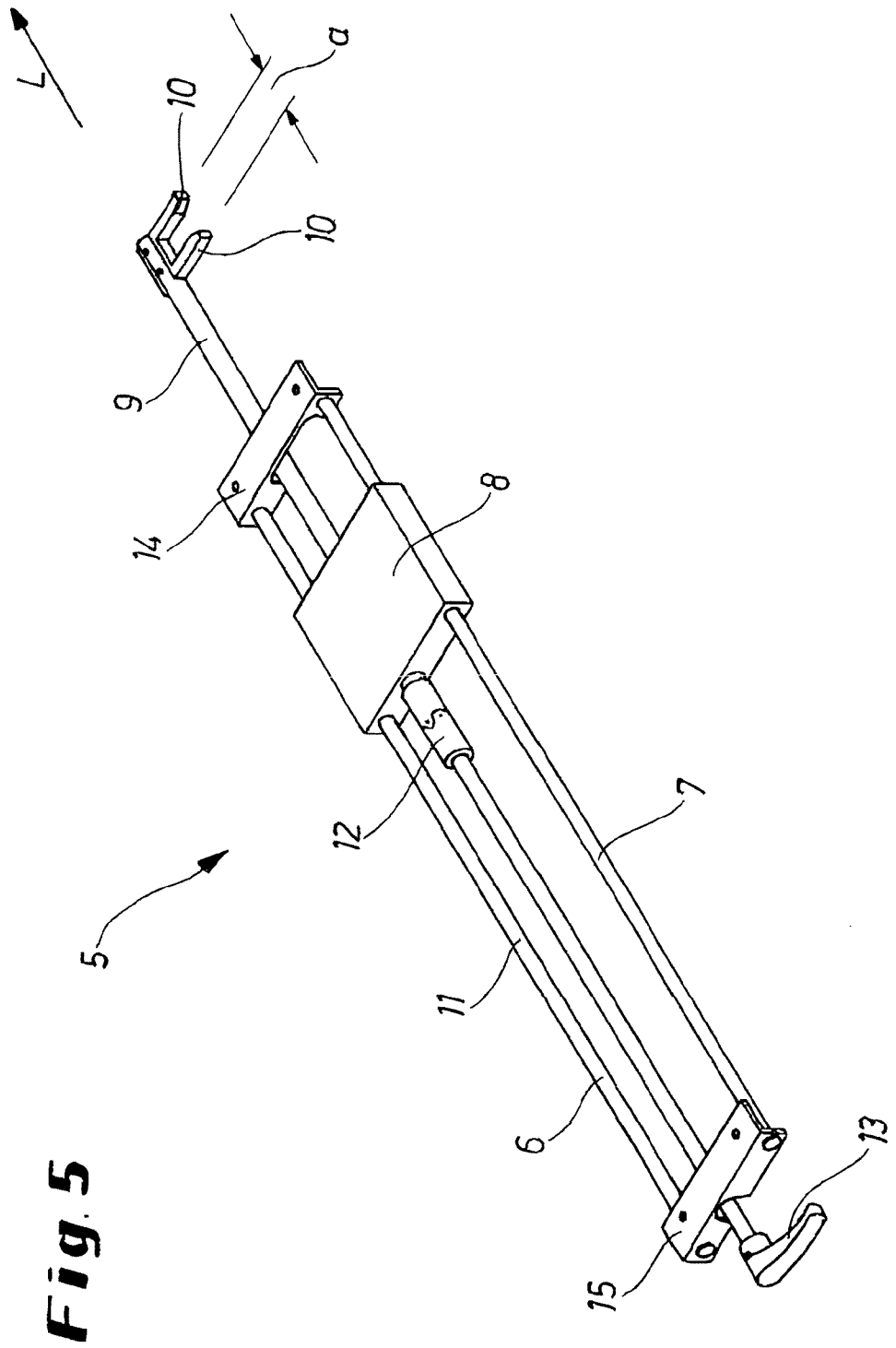
**Fig. 2**



**Fig. 4**

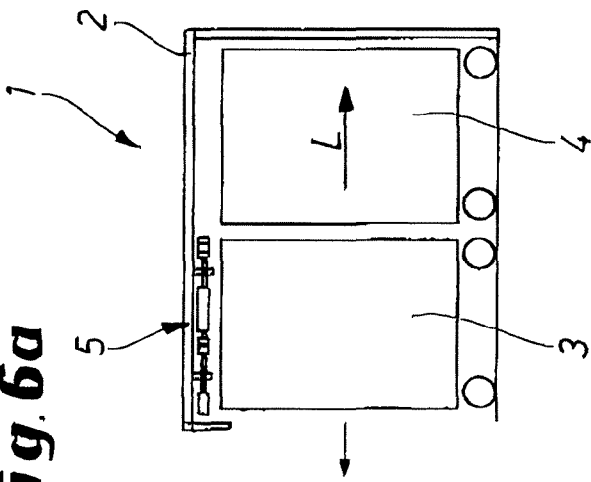


**Fig. 3**

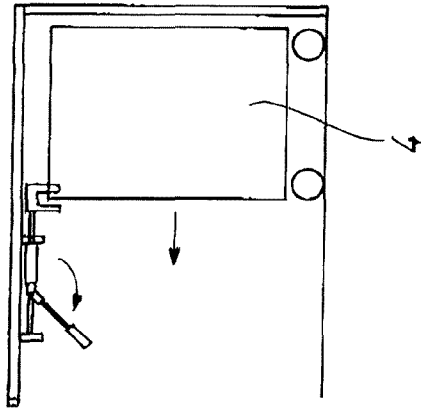


**Fig. 5**

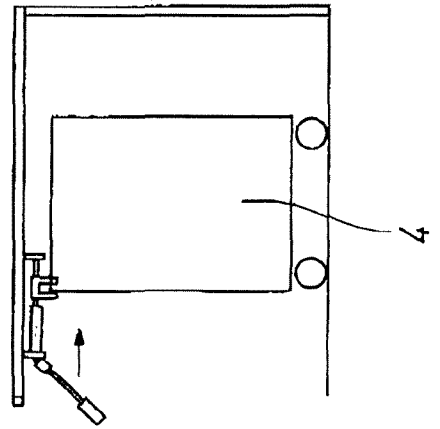
**Fig. 6a**



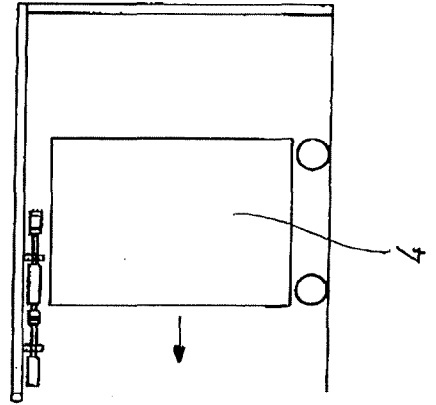
**Fig. 6b**



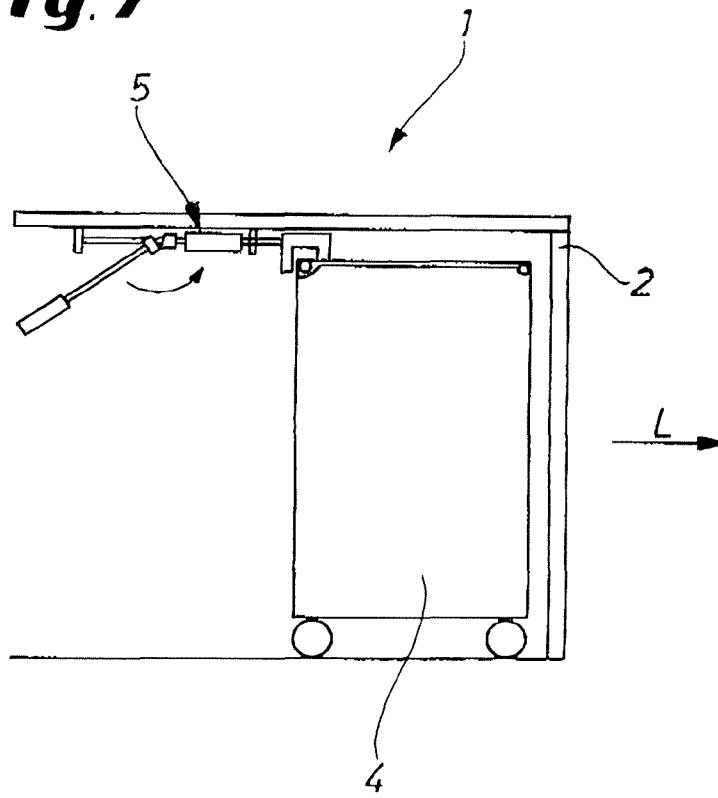
**Fig. 6c**



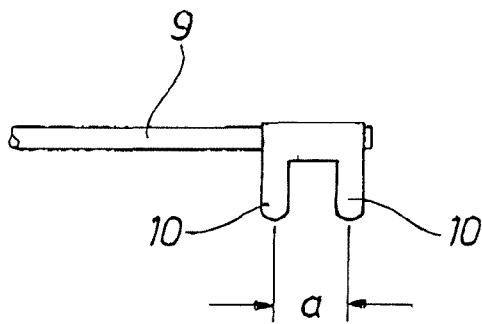
**Fig. 6d**



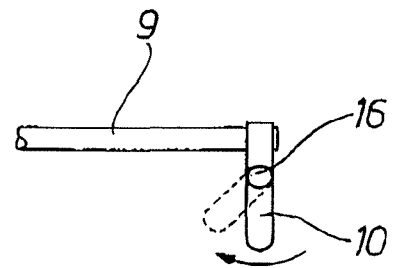
**Fig. 7**



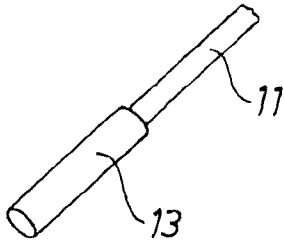
**Fig. 8**



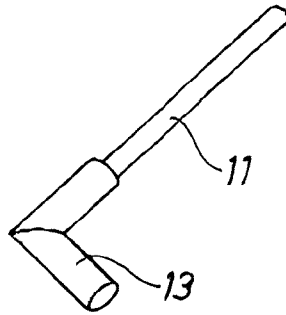
**Fig. 9**



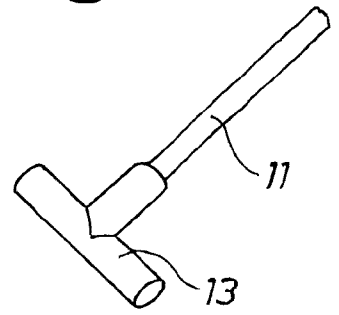
**Fig. 10**



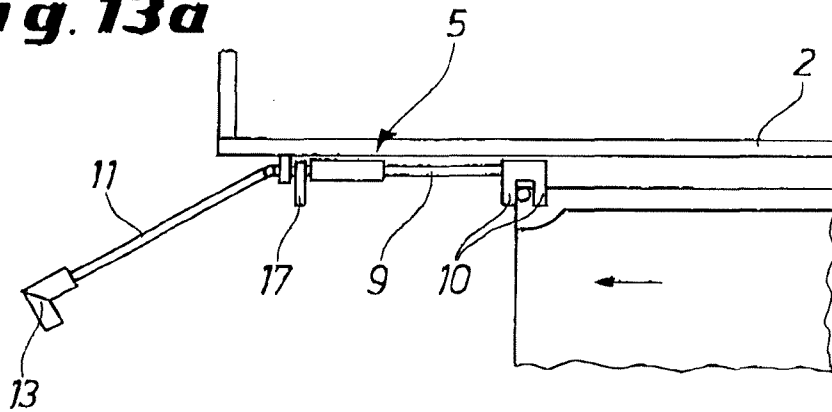
**Fig. 11**



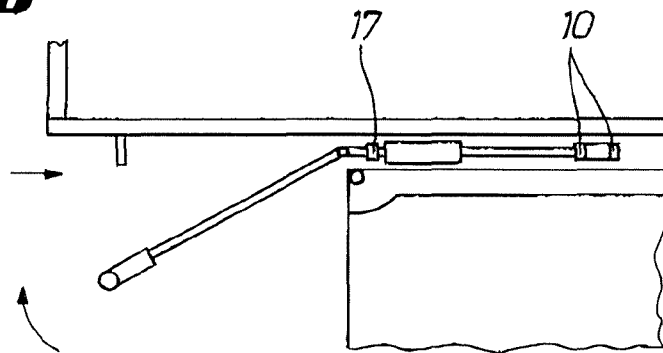
**Fig. 12**



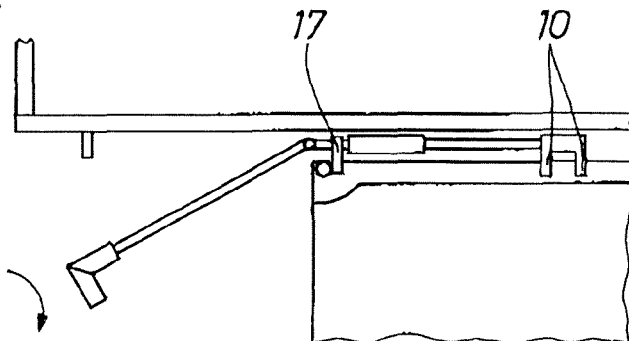
**Fig. 13a**



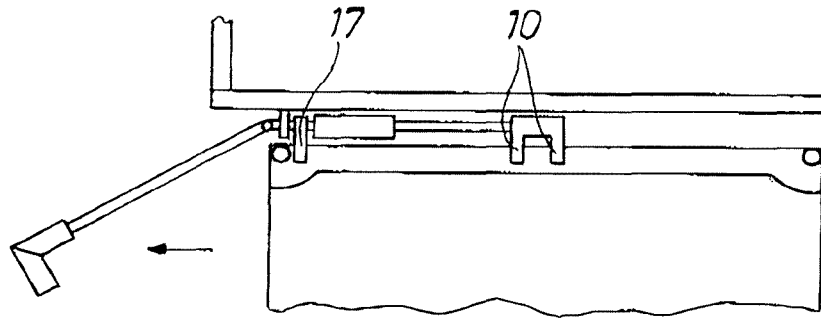
**Fig. 13b**



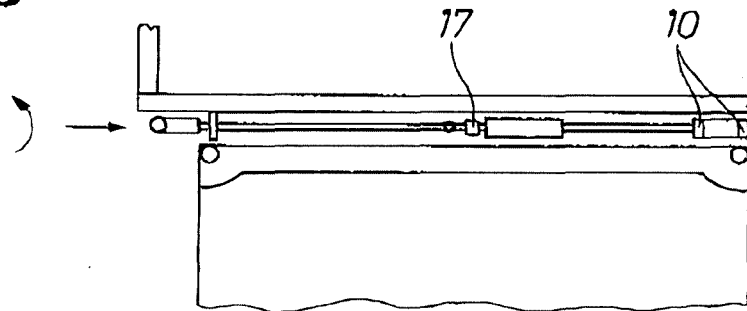
**Fig. 13c**



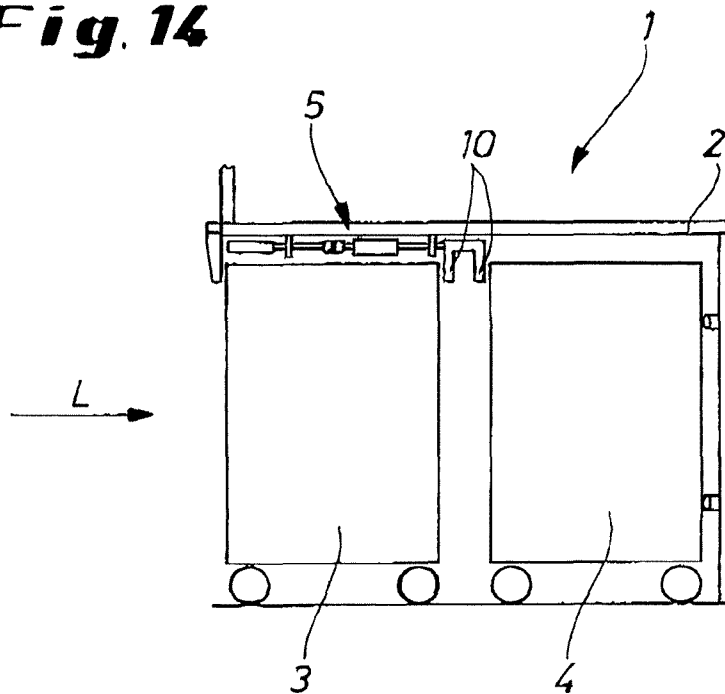
**Fig. 13d**



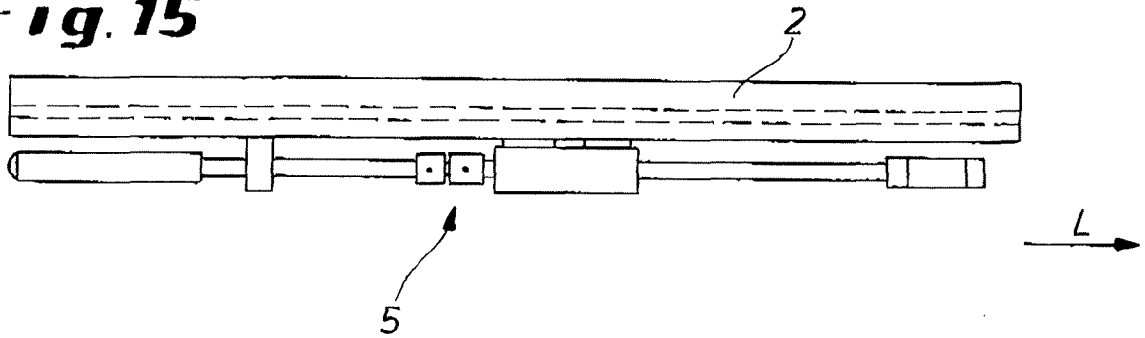
**Fig. 13e**



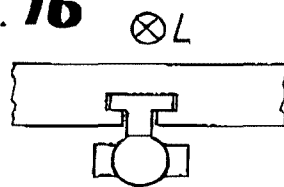
**Fig. 14**



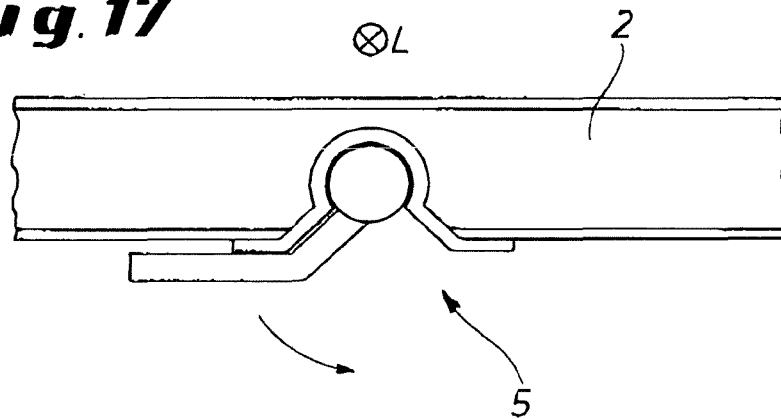
**Fig. 15**



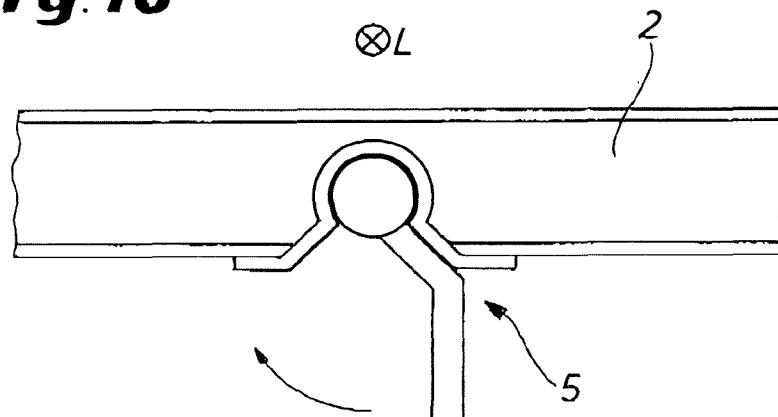
**Fig. 16**



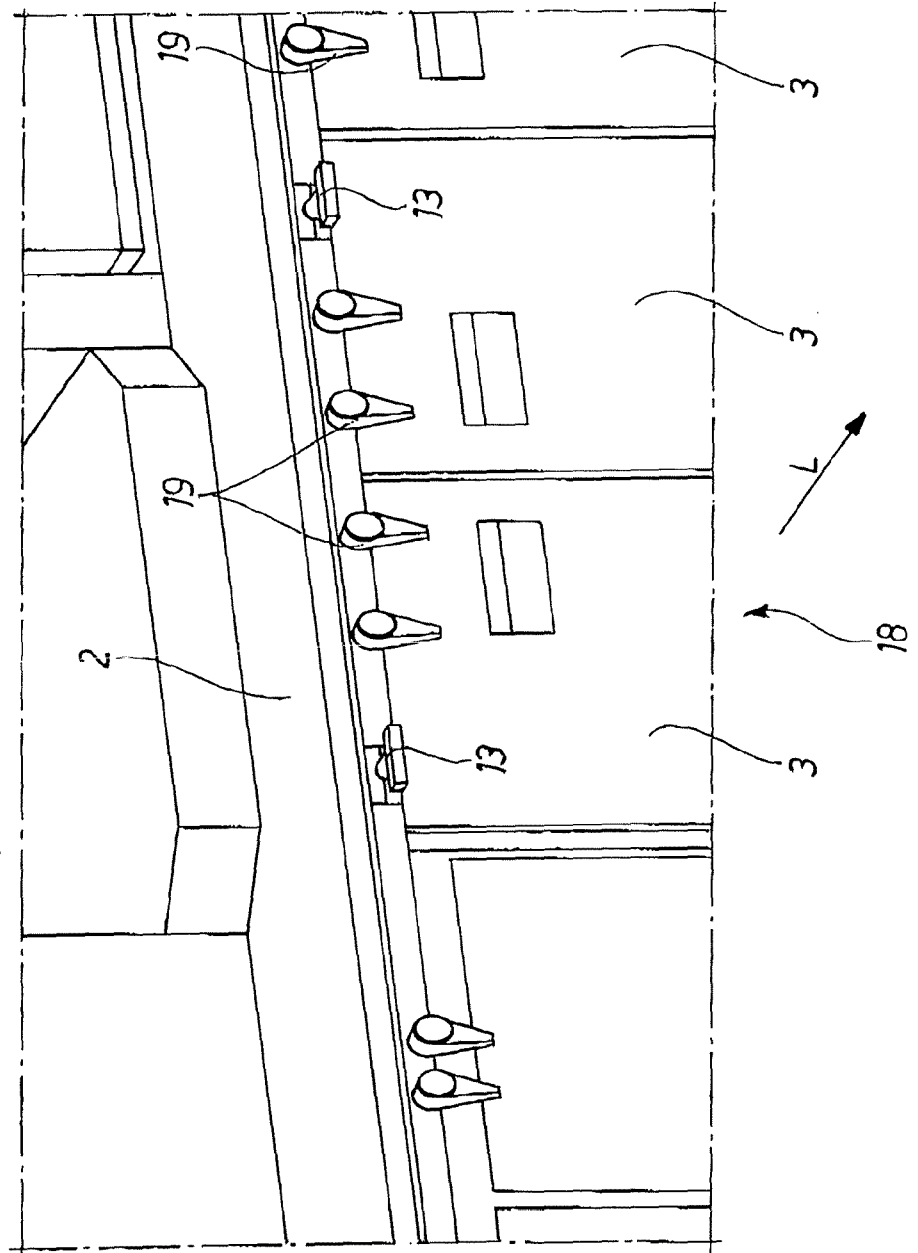
**Fig. 17**



**Fig. 18**



**Fig. 19**



**INTERNATIONAL SEARCH REPORT**

International application No  
PCT/EP2015/069827

A. CLASSIFICATION OF SUBJECT MATTER  
INV. B64D11/00 B64D11/04  
ADD.  
According to International Patent Classification (IPC) or to both national classification and IPC

B. FIELDS SEARCHED  
Minimum documentation searched (classification system followed by classification symbols)  
B64D

Documentation searched other than minimum documentation to the extent that such documents are included in the fields searched

Electronic data base consulted during the international search (name of data base and, where practicable, search terms used)  
EPO-Internal, WPI Data

C. DOCUMENTS CONSIDERED TO BE RELEVANT

Category*	Citation of document, with indication, where appropriate, of the relevant passages	Relevant to claim No.
A	US 2014/166806 A1 (DURAND YVES [FR] ET AL) 19 June 2014 (2014-06-19) paragraph [0123] - paragraph [0127] paragraph [0140] - paragraph [0144]; figures	1-14
A	WO 2014/125046 A1 (SELL GMBH [DE]) 21 August 2014 (2014-08-21) cited in the application page 10, line 7 - line 19; figures 13,14	1-14
A	US 2013/259612 A1 (GUERING BERNARD [FR]) 3 October 2013 (2013-10-03) paragraph [0083] - paragraph [0085] paragraph [0094] - paragraph [0097]; figures	1-14

Further documents are listed in the continuation of Box C.

See patent family annex.

\* Special categories of cited documents :

- "A" document defining the general state of the art which is not considered to be of particular relevance
- "E" earlier application or patent but published on or after the international filing date
- "L" document which may throw doubts on priority claim(s) or which is cited to establish the publication date of another citation or other special reason (as specified)
- "O" document referring to an oral disclosure, use, exhibition or other means
- "P" document published prior to the international filing date but later than the priority date claimed

- "T" later document published after the international filing date or priority date and not in conflict with the application but cited to understand the principle or theory underlying the invention
- "X" document of particular relevance; the claimed invention cannot be considered novel or cannot be considered to involve an inventive step when the document is taken alone
- "Y" document of particular relevance; the claimed invention cannot be considered to involve an inventive step when the document is combined with one or more other such documents, such combination being obvious to a person skilled in the art
- "&" document member of the same patent family

Date of the actual completion of the international search <b>2 December 2015</b>	Date of mailing of the international search report <b>10/12/2015</b>
---	---

Name and mailing address of the ISA/ European Patent Office, P.B. 5818 Patentlaan 2 NL - 2280 HV Rijswijk Tel. (+31-70) 340-2040, Fax: (+31-70) 340-3016	Authorized officer <b>Silva d'Oliveira, M</b>
--	--

# INTERNATIONAL SEARCH REPORT

Information on patent family members

International application No

PCT/EP2015/069827

Patent document cited in search report	Publication date	Patent family member(s)	Publication date	
US 2014166806	A1	19-06-2014	CN 103863565 A	18-06-2014
			EP 2743182 A2	18-06-2014
			FR 2999546 A1	20-06-2014
			US 2014166806 A1	19-06-2014
-----				
WO 2014125046	A1	21-08-2014	EP 2956361 A1	23-12-2015
			WO 2014125046 A1	21-08-2014
-----				
US 2013259612	A1	03-10-2013	CN 103068676 A	24-04-2013
			FR 2964085 A1	02-03-2012
			US 2013259612 A1	03-10-2013
			WO 2012025673 A1	01-03-2012
-----				