



(72) DOBAK, JOHN D., III, US

(71) DEL MAR MEDICAL TECHNOLOGIES, INC., US

(51) Int.Cl.⁶ A61B 17/36

(30) 1998/01/23 (09/012,287) US

(54) **PROCEDE ET DISPOSITIF SELECTIFS SERVANT
A METTRE UN ORGANE EN HYPOTHERMIE**

(54) **SELECTIVE ORGAN HYPOTHERMIA METHOD
AND APPARATUS**

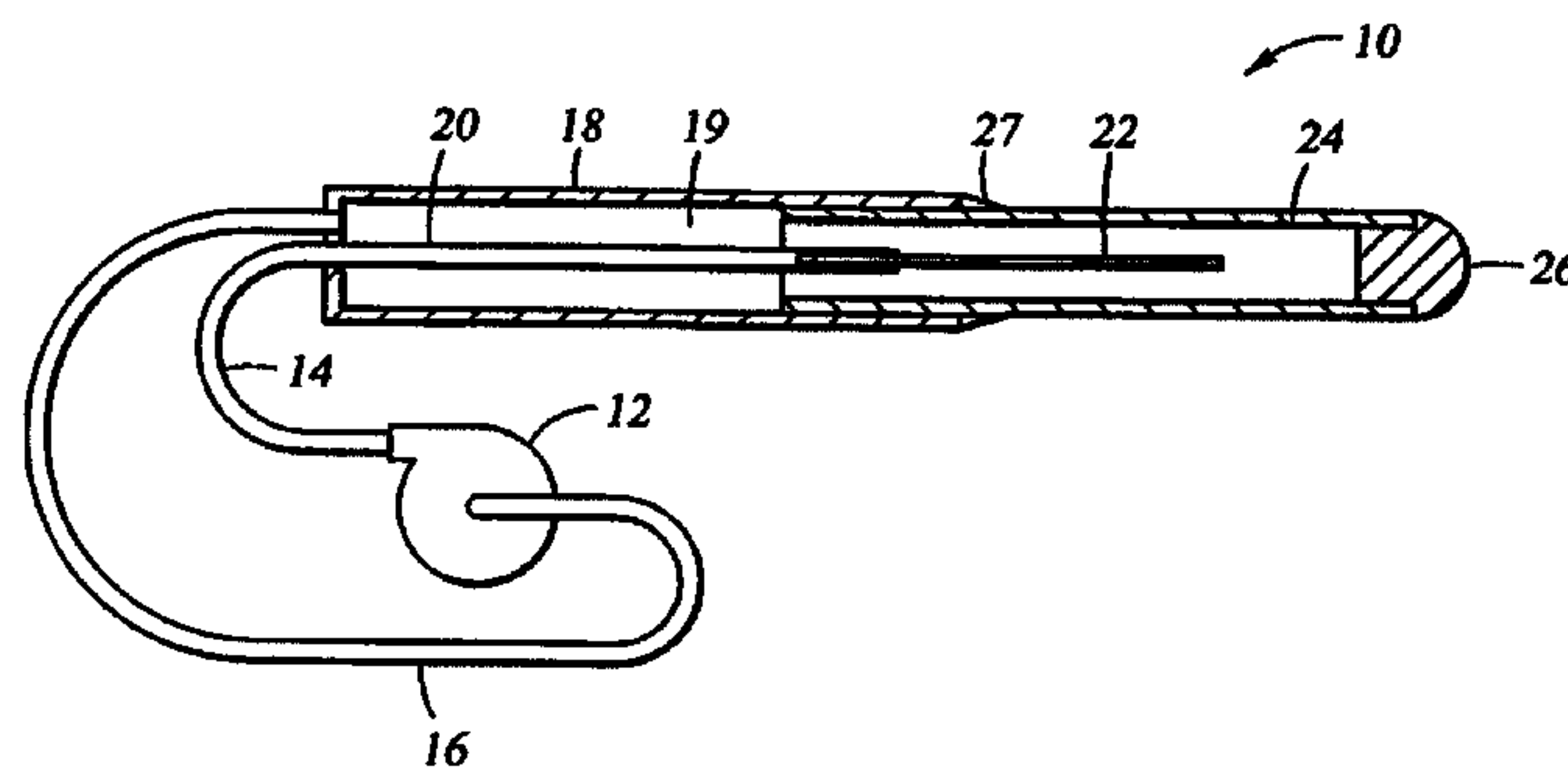

(57) L'invention concerne un procédé et un dispositif servant à mettre en hypothermie un organe corporel sélectionné sans exercer d'effet conséquent sur les organes situés à proximité ou sur d'autres tissus. On insère un cathéter souple (10) à travers le système vasculaire d'un patient, de manière à placer la pointe distale (26) du cathéter dans une artère alimentant l'organe sélectionné. On pompe un réfrigérant sous pression à travers le cathéter vers un élément de dilatation (11) situé à proximité de la pointe distale du cathéter, dans lequel ce réfrigérant se vaporise et se dilate, de façon à refroidir un élément souple de transfert de chaleur (24) placé dans la pointe distale du cathéter. Cet élément de transfert de chaleur refroidit le sang s'écoulant à travers l'artère afin de refroidir l'organe sélectionné, en position distale par rapport à la pointe du cathéter.

(57) The present invention is a method, and apparatus for performing hypothermia of a selected body organ without significant effect on surrounding organs or other tissue. A flexible catheter (10) is inserted through the vascular system of a patient to place the distal tip (26) of the catheter in an artery feeding the selected organ. A compressed refrigerant is pumped through the catheter to an expansion element (22) near the distal tip of the catheter, where the refrigerant vaporizes, and expands to cool a flexible heat transfer element (24) in the distal tip of the catheter. The heat transfer element cools the blood flowing through the artery to cool the selected organ, distal to the tip of the catheter.



PCT

WORLD INTELLECTUAL PROPERTY ORGANIZATION
International Bureau

INTERNATIONAL APPLICATION PUBLISHED UNDER THE PATENT COOPERATION TREATY (PCT)

(51) International Patent Classification ⁶ : A61B 17/36	A1	(11) International Publication Number: WO 99/37226 (43) International Publication Date: 29 July 1999 (29.07.99)
--	-----------	---

(21) International Application Number: PCT/US99/01275

(22) International Filing Date: 21 January 1999 (21.01.99)

(30) Priority Data:
09/012,287 23 January 1998 (23.01.98) US(71) Applicant: DEL MAR MEDICAL TECHNOLOGIES, INC.
[US/US]; Suite 106, 6199 Cornerstone Court, East, San Diego, CA 92121 (US).

(72) Inventor: DOBAK, John, D., III; 2385 Ridgeway Row, La Jolla, CA 92037 (US).

(74) Agent: SPINKS, Gerald, W.; P.O. Box 10158, College Station, TX 77842-0158 (US).

(81) Designated States: AU, CA, JP, European patent (AT, BE, CH, CY, DE, DK, ES, FI, FR, GB, GR, IE, IT, LU, MC, NL, PT, SE).

Published*With international search report.
With amended claims.*

(54) Title: SELECTIVE ORGAN HYPOTHERMIA METHOD AND APPARATUS

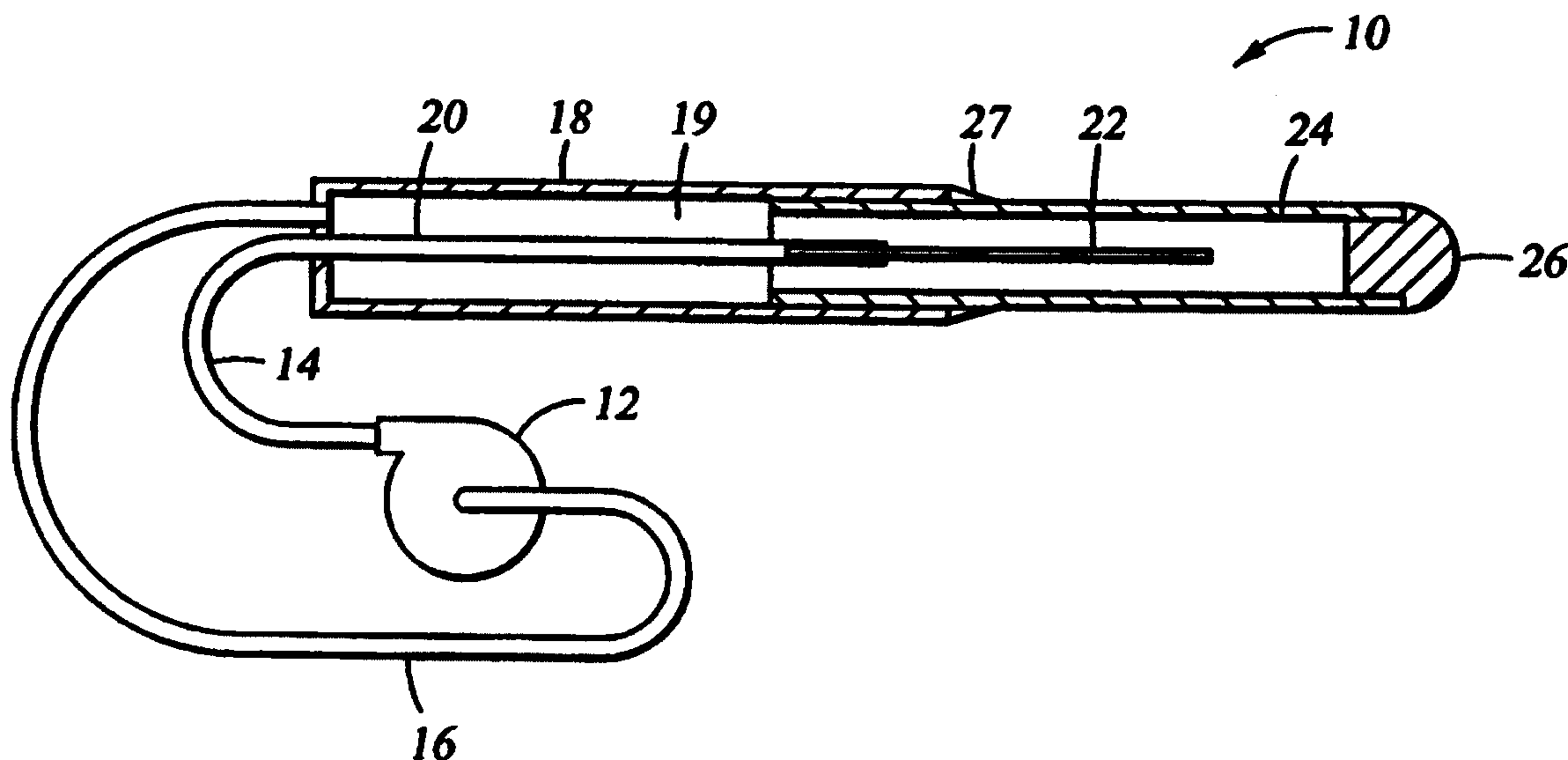

(57) Abstract

The present invention is a method, and apparatus for performing hypothermia of a selected body organ without significant effect on surrounding organs or other tissue. A flexible catheter (10) is inserted through the vascular system of a patient to place the distal tip (26) of the catheter in an artery feeding the selected organ. A compressed refrigerant is pumped through the catheter to an expansion element (22) near the distal tip of the catheter, where the refrigerant vaporizes, and expands to cool a flexible heat transfer element (24) in the distal tip of the catheter. The heat transfer element cools the blood flowing through the artery to cool the selected organ, distal to the tip of the catheter.

TITLE OF THE INVENTION

Selective Organ Hypothermia Method And Apparatus

BACKGROUND OF THE INVENTION

5 Field of the Invention - The current invention relates to selective cooling, or hypothermia, of an organ, such as the brain, by cooling the blood flowing into the organ. This cooling can protect the tissue from injury caused by anoxia or trauma.

Background Information - Organs of the human body, such as the brain, kidney, and heart, are maintained at a constant temperature of approximately 37° C. Cooling of organs below 35° C is known to provide cellular protection from anoxic damage caused by a disruption of blood supply, or by trauma. Cooling can also reduce swelling associated with these injuries.

Hypothermia is currently utilized in medicine and is sometimes performed to protect the brain from injury. Cooling of the brain is generally accomplished through whole body cooling to create a condition of total body hypothermia in the range of 20° to 30° C. This cooling is accomplished by immersing the patient in ice, by using cooling blankets, or by cooling the blood flowing externally through a cardiopulmonary bypass machine. U. S. Pat. No. 3,425,419 to Dato and U. S. Pat. No. 5,486,208 to Ginsburg disclose catheters for cooling the blood to create total body hypothermia. However, they rely on circulating a cold fluid to produce cooling. This is unsuitable for selective organ hypothermia, because cooling of the entire catheter by the cold fluid on its way to the organ would ultimately result in non-selective, or total body, cooling.

Total body hypothermia to provide organ protection has a number of drawbacks. First, it creates cardiovascular problems, such as cardiac arrhythmias, reduced cardiac output, and increased systemic vascular resistance. These side effects can result in organ damage. These side effects are believed to be caused reflexively in response to the reduction in core body temperature. Second, total body hypothermia is difficult to administer. Immersing a patient in ice water clearly has its associated problems. Placement on cardiopulmonary bypass requires surgical intervention and specialists to operate the machine, and it is associated with a number of complications including bleeding and volume overload. Third, the time required to reduce the body

temperature and the organ temperature is prolonged. Minimizing the time between injury and the onset of cooling has been shown to produce better clinical outcomes.

Some physicians have immersed the patient's head in ice to provide brain cooling. There are also cooling helmets, or head gear, to perform the same. This approach suffers from the problems of slow cool down and poor temperature control due to the temperature gradient that must be established externally to internally. It has also been shown that complications associated with total body cooling, such as arrhythmia and decreased cardiac output, can also be caused by cooling of the face and head only.

10 Selective organ hypothermia has been studied by Schwartz, et. al. Utilizing baboons, blood was circulated and cooled externally from the body via the femoral artery and returned to the body through the carotid artery. This study showed that the brain could be selectively cooled to temperatures of 20° C without reducing the temperature of the entire body. Subsequently, cardiovascular complications associated total body hypothermia did not occur. However, external circulation of the blood for cooling is not a practical approach for the treatment of humans. The risks of infection, bleeding, and fluid imbalance are great. Also, at least two arterial vessels must be punctured and cannulated. Further, percutaneous cannulation of the carotid artery is very difficult and potentially fatal, due to the associated arterial wall trauma. Also, 15 20 this method could not be used to cool organs such as the kidneys, where the renal arteries cannot be directly cannulated percutaneously.

Selective organ hypothermia has also been attempted by perfusing the organ with a cold solution, such as saline or perflourocarbons. This is commonly done to protect the heart during heart surgery and is referred to as cardioplegia. This procedure has a number of drawbacks, including limited time of administration due to excessive volume accumulation, cost and inconvenience of maintaining the perfusate, and lack of effectiveness due to temperature dilution from the blood. Temperature dilution by the blood is a particular problem in high blood flow organs such as the brain. For cardioplegia, the blood flow to the heart is minimized, and therefore this effect is minimized. 25 30

Intravascular, selective organ hypothermia, created by cooling the blood flowing into the organ, is the ideal method. First, because only the target organ is

cooled, complications associated with total body hypothermia are avoided. Second, because the blood is cooled intravascularly, or in situ, problems associated with external circulation of blood are eliminated. Third, only a single puncture and arterial vessel cannulation is required, and it can be performed at an easily accessible artery
5 such as the femoral, subclavian, or brachial. Fourth, cold perfusate solutions are not required, thus eliminating problems with excessive fluid accumulation. This also eliminates the time, cost, and handling issues associated with providing and maintaining cold perfusate solution. Fifth, rapid cooling can be achieved. Sixth, precise temperature control is possible.

10 Previous inventors have disclosed the circulation of a cold fluid to produce total body hypothermia, by placing a probe into a major vessel of the body. This approach is entirely unfeasible when considering selective organ hypothermia, as will be demonstrated below.

The important factor related to catheter development for selective organ
15 hypothermia is the small size of the typical feeding artery, and the need to prevent a significant reduction in blood flow when the catheter is placed in the artery. A significant reduction in blood flow would result in ischemic organ damage. While the diameter of the major vessels of the body, such as the vena cava and aorta, are as large as 15 to 20 mm., the diameter of the feeding artery of an organ is typically only 4.0 to
20 8.0 mm. Thus, a catheter residing in one of these arteries cannot be much larger than 2.0 to 3.0 mm. in outside diameter. It is not practical to construct a selective organ hypothermia catheter of this small size using the circulation of cold water or other fluid. Using the brain as an example, this point will be illustrated.

The brain typically has a blood flow rate of approximately 500 to 750 cc/min.
25 Two carotid arteries feed this blood supply to the brain. The internal carotid is a small diameter artery that branches off of the common carotid near the angle of the jaw. To cool the brain, it is important to place some of the cooling portion of the catheter into the internal carotid artery, so as to minimize cooling of the face via the external carotid, since face cooling can result in complications, as discussed above. It would
30 be desirable to cool the blood in this artery down to 32°C, to achieve the desired cooling of the brain. To cool the blood in this artery by a 5C° drop, from 37°C down to 32°C, requires between 100 and 150 watts of refrigeration power.

In order to reach the internal carotid artery from a femoral insertion point, an overall catheter length of approximately 100 cm. would be required. To avoid undue blockage of the blood flow, the outside diameter of the catheter can not exceed approximately 2 mm. Assuming a coaxial construction, this limitation in diameter would dictate an internal supply tube of about 0.70 mm. diameter, with return flow being between the internal tube and the external tube.

A catheter based on the circulation of water or saline operates on the principle of transferring heat from the blood to raise the temperature of the water. Rather than absorbing heat by boiling at a constant temperature like a freon, water must warm up to absorb heat and produce cooling. Water flowing at the rate of 5.0 grams/sec, at an initial temperature of 0°C and warming up to 5°C, can absorb 100 watts of heat. Thus, the outer surface of the heat transfer element could only be maintained at 5°C, instead of 0°C. This will require the heat transfer element to have a surface area of approximately 1225 mm². If a catheter of approximately 2.0 mm. diameter is assumed, the length of the heat transfer element would have to be approximately 20 cm.

In actuality, because of the overall length of the catheter, the water would undoubtedly warm up before it reached the heat transfer element, and provision of 0°C water at the heat transfer element would be impossible. Circulating a cold liquid would cause cooling along the catheter body and could result in non-specific or total body hypothermia. Furthermore, to achieve this heat transfer rate, 5 grams/sec of water flow are required. To circulate water through a 100 cm. long, 0.70 mm. diameter supply tube at this rate produces a pressure drop of more than 3000 psi. This pressure exceeds the safety levels of many flexible medical grade plastic catheters. Further, it is doubtful whether a water pump that can generate these pressures and flow rates can be placed in an operating room.

BRIEF SUMMARY OF THE INVENTION

The selective organ cooling achieved by the present invention is accomplished by placing a cooling catheter into the feeding artery of the organ. The cooling catheter is based on the vaporization and expansion of a compressed and condensed refrigerant, such as freon. In the catheter, a shaft or body section would carry the

liquid refrigerant to a distal heat transfer element where vaporization, expansion, and cooling would occur. Cooling of the catheter tip to temperatures above minus 2°C results in cooling of the blood flowing into the organ located distally of the catheter tip, and subsequent cooling of the target organ. For example, the catheter could be placed into the internal carotid artery, to cool the brain. The size and location of this artery places significant demands on the size and flexibility of the catheter. Specifically, the outside diameter of the catheter must be minimized, so that the catheter can fit into the artery without compromising blood flow. An appropriate catheter for this application would have a flexible body of 70 to 100 cm. in length and 2.0 to 3.0 mm. in outside diameter.

It is important for the catheter to be flexible in order to successfully navigate the arterial path, and this is especially true of the distal end of the catheter. So, the distal end of the catheter must have a flexible heat transfer element, which is composed of a material which conducts heat better than the remainder of the catheter. The catheter body material could be nylon or PBAX, and the heat transfer element could be made from nitinol, which would have approximately 70 to 100 times the thermal conductivity of the catheter body material, and which is also superelastic. Nitinol could also be treated to undergo a transition to another shape, such as a coil, once it is placed in the proper artery. Certain tip shapes could improve heat transfer as well as allow the long tip to reside in arteries of shorter length.

The heat transfer element would require sufficient surface area to absorb 100 to 150 watts of heat. This could be accomplished with a 2 mm. diameter heat transfer tube, 15 to 18 cm. in length, with a surface temperature of 0°C. Fins can be added to increase the surface area, or to maintain the desired surface area while shortening the length.

The cooling would be provided by the vaporization and expansion of a liquid refrigerant, such as a freon, across an expansion element, such as a capillary tube. For example, freon R12 boiling at 1 atmosphere and a flow rate of between 0.11 and 0.18 liter/sec could provide between approximately 100 and 150 watts of refrigeration power. Utilizing a liquid refrigerant allows the cooling to be focused at the heat transfer element, thereby eliminating cooling along the catheter body. Utilizing boiling heat transfer to the expanded fluid also lowers the fluid flow rate requirement

to remove the necessary amount of heat from the blood. This is important because the required small diameter of the catheter would have higher pressure drops at higher flow rates.

The catheter would be built in a coaxial construction with a 0.70 mm. inner supply tube diameter and a 2.0 mm. outer return tube diameter. This limits the pressure drops of the freon along the catheter length, as well as minimizing the catheter size to facilitate carotid placement. The inner tube would carry the liquid freon to the tubular heat transfer element at the distal end of the catheter body. If a heat transfer element surface temperature of 0°C is maintained, just above the freezing point of blood, then 940 mm² of surface area in contact with the blood are required to lower the temperature of the blood by the specified 5C° drop. This translates to a 2.0 mm. diameter heat transfer tube by 15 cm. in length. To generate 0°C on the nitinol surface, the freon must boil at a temperature of minus 28°C. It is important to have boiling heat transfer, which has a higher heat transfer coefficient, to maintain the surface temperature at 0°C. There are several freons that can be controlled to boil at minus 28°C, such as a 50/50 mixture of pentafluoroethane and 1,1,1 trifluoroethane or a 50/50 mixture of difluoromethane and pentafluoroethane. The 50/50 mixture of pentafluoroethane and 1,1,1 trifluoroethane would require a flow rate of approximately 7.0 liters/min or 0.52 gram/sec to absorb 100 watts of heat. At this flow rate, the pressure drop along the inner tube is less than 7 psi in 100 cm. of length, and the pressure drop along the outer tube is less than 21 psi in 100 cm. of length.

The inner supply tube of the catheter would be connected to a condenser, fed by the high pressure side of a compressor, and the outer return tube of the catheter would be connected to the low pressure side of the compressor.

The novel features of this invention, as well as the invention itself, will be best understood from the attached drawings, taken along with the following description, in which similar reference characters refer to similar parts, and in which:

BRIEF DESCRIPTION OF THE SEVERAL VIEWS OF THE DRAWINGS

Figure 1 is a schematic, partially in section, showing a first embodiment of the flexible catheter according to the present invention;

Figure 2 is a perspective view of a second embodiment of the distal tip of the catheter of the present invention, after transformation;

Figure 3 is a section view of a third embodiment of the distal tip of the catheter of the present invention, after expansion of the heat transfer element;

5 Figure 4 is a partial section view of a fourth embodiment of the distal tip of the catheter of the present invention, after transformation;

Figure 5 is an elevation view of a fifth embodiment of the distal tip of the catheter of the present invention, before transformation;

10 Figure 6 is an elevation view of the embodiment shown in Figure 5, after transformation to a double helix;

Figure 7 is an elevation view of the embodiment shown in Figure 5, after transformation to a looped coil;

15 Figure 8 is an elevation view of a sixth embodiment of the distal tip of the catheter of the present invention, showing longitudinal fins on the heat transfer element;

Figure 9 is an end view of the embodiment shown in Figure 8;

Figure 10 is an elevation view of a seventh embodiment of the distal tip of the catheter of the present invention, showing annular fins on the heat transfer element;
and

20 Figure 11 is an end view of the embodiment shown in Figure 10.

DETAILED DESCRIPTION OF THE INVENTION

As shown in Figure 1, the apparatus of the present invention includes a flexible catheter assembly 10, fed by a refrigeration compressor unit 12, which can include a condenser. The compressor unit 12 has an outlet 14 and an inlet 16. The catheter assembly 10 has an outer flexible catheter body 18, which can be made of braided PBAX or other suitable catheter material. The catheter body 18 must be flexible, to enable passage through the vascular system of the patient to the feeding artery of the selected organ. The inner lumen 19 of the catheter body 18 serves as the return flow path for the expanded refrigerant. The catheter assembly 10 also has an inner flexible refrigerant supply conduit 20, which can be made of nylon, polyimide, nitinol, or other suitable catheter material. The length and diameter of the catheter

body 18 and refrigerant supply conduit 20 are designed for the size and location of the artery in which the apparatus will be used. For use in the internal carotid artery to achieve hypothermia of the brain, the catheter body 18 and refrigerant supply conduit 20 will have a length of approximately 70 to 100 centimeters. The catheter body 18
5 for this application will have an outside diameter of approximately 2.5 millimeters and an inside diameter of approximately 2.0 millimeters, and the refrigerant supply conduit will have an outside diameter of approximately 1.0 millimeter and an inside diameter of approximately 0.75 millimeter. A supply conduit 20 of this diameter will have a refrigerant pressure drop of only approximately 0.042 atmospheres per 100
10 centimeters. The return flow path through a catheter body 18 of this diameter will have a refrigerant pressure drop of only approximately 0.064 atmospheres per 100 centimeters.

The compressor outlet 14 is attached in fluid flow communication, by known means, to a proximal end of the refrigerant supply conduit 20 disposed coaxially
15 within said catheter body 18. The distal end of the refrigerant supply conduit 20 is attached to an expansion element, which in this embodiment is a capillary tube 22 having a length of approximately 15 to 25 centimeters. The capillary tube 22 can be made of polyimide or nitinol, or other suitable material, and it can be a separate element attached to the supply conduit 20, or it can be an integral portion of the
20 supply conduit 20. For the internal carotid artery application, the capillary tube 22 will have an outside diameter of approximately 0.6 millimeter and an inside diameter of approximately 0.25 millimeter. The expansion element, such as the capillary tube 22, has an outlet within a chamber of a flexible heat transfer element such as the hollow flexible tube 24. The tube 24 shown in this embodiment is flexible but
25 essentially straight in its unflexed state. The heat transfer element must be flexible, to enable passage through the vascular system of the patient to the feeding artery of the selected organ. For the internal carotid application the flexible tube 24 will have a length of approximately 15 centimeters, an outside diameter of approximately 1.9 millimeters and an inside diameter of approximately 1.5 millimeters. The heat
30 transfer element also includes a plug 26 in the distal end of the flexible tube 24. The plug 26 can be epoxy potting material, plastic, or a metal such as stainless steel or

gold. A tapered transition of epoxy potting material can be provided between the catheter body 18 and the flexible tube 24.

5 A refrigerant, such as freon, is compressed, condensed, and pumped through the refrigerant supply conduit 20 to the expansion element, or capillary tube, 22. The refrigerant vaporizes and expands into the interior chamber of the heat transfer element, such as the flexible tube 24, thereby cooling the heat transfer element 24. Blood in the feeding artery flows around the heat transfer element 24, thereby being cooled. The blood then continues to flow distally into the selected organ, thereby cooling the organ.

10 A second embodiment of the heat transfer element is shown in Figure 2. This embodiment can be constructed of a tubular material such as nitinol, which has a temperature dependent shape memory. The heat transfer element 28 can be originally shaped like the flexible tube 24 shown in Figure 1, at room temperature, but trained to take on the coiled tubular shape shown in Figure 2 at a lower temperature. This
15 allows easier insertion of the catheter assembly 10 through the vascular system of the patient, with the essentially straight but flexible tubular shape, similar to the flexible tube 24. Then, when the heat transfer element is at the desired location in the feeding artery, such as the internal carotid artery, refrigerant flow is commenced. As the expanding refrigerant, such as a 50/50 mixture of pentafluoroethane and 1,1,1
20 trifluoroethane or a 50/50 mixture of difluoromethane and pentafluoroethane, cools the heat transfer element down, the heat transfer element takes on the shape of the heat transfer coil 28 shown in Figure 2. This enhances the heat transfer capacity, while limiting the length of the heat transfer element.

A third embodiment of the expansion element and the heat transfer element is
25 shown in Figure 3. This embodiment of the expansion element is an orifice 30, shown at the distal end of the refrigerant supply conduit 20. The outlet of the orifice 30 discharges into an expansion chamber 32. In this embodiment, the heat transfer element is a plurality of hollow tubes 34 leading from the expansion chamber 32 to the refrigerant return lumen 19 of the catheter body 18. This embodiment of the heat
30 transfer element 34 can be constructed of a tubular material such as nitinol, which has a temperature dependent shape memory, or some other tubular material having a permanent bias toward a curved shape. The heat transfer element tubes 34 can be

essentially straight, originally, at room temperature, but trained to take on the outwardly flexed "basket" shape shown in Figure 3 at a lower temperature. This allows easier insertion of the catheter assembly 10 through the vascular system of the patient, with the essentially straight but flexible tubes. Then, when the heat transfer element 34 is at the desired location in the feeding artery, such as the internal carotid artery, refrigerant flow is commenced. As the expanding refrigerant cools the heat transfer element 34 down, the heat transfer element takes on the basket shape shown in Figure 3. This enhances the heat transfer capacity, while limiting the length of the heat transfer element.

10 A fourth embodiment of the heat transfer element is shown in Figure 4. This embodiment can be constructed of a material such as nitinol. The heat transfer element 36 can be originally shaped as a long loop extending from the distal end of the catheter body 18, at room temperature, but trained to take on the coiled tubular shape shown in Figure 4 at a lower temperature, with the heat transfer element 36
15 coiled around the capillary tube 22. This allows easier insertion of the catheter assembly 10 through the vascular system of the patient, with the essentially straight but flexible tubular loop shape. Then, when the heat transfer element 36 is at the desired location in the feeding artery, such as the internal carotid artery, refrigerant flow is commenced. As the expanding refrigerant cools the heat transfer element
20 down, the heat transfer element takes on the shape of the coil 36 shown in Figure 4. This enhances the heat transfer capacity, while limiting the length of the heat transfer element 36. Figure 4 further illustrates that a thermocouple 38 can be incorporated into the catheter body 18 for temperature sensing purposes.

Yet a fifth embodiment of the heat transfer element is shown in Figures 5, 6,
25 and 7. In this embodiment, an expansion element, such as a capillary tube or orifice, is incorporated within the distal end of the catheter body 18. This embodiment of the heat transfer element can be constructed of a material such as nitinol. The heat transfer element is originally shaped as a long loop 40 extending from the distal end of the catheter body 18, at room temperature. The long loop 40 has two sides 42, 44,
30 which are substantially straight but flexible at room temperature. The sides 42, 44 of the long loop 40 can be trained to take on the double helical shape shown in Figure 6 at a lower temperature, with the two sides 42, 44 of the heat transfer element 40 coiled

around each other. Alternatively, the sides 42, 44 of the long loop 40 can be trained to take on the looped coil shape shown in Figure 7 at a lower temperature, with each of the two sides 42, 44 of the heat transfer element 40 coiled independently. Either of these shapes allows easy insertion of the catheter assembly 10 through the vascular system of the patient, with the essentially straight but flexible tubular loop shape. Then, when the heat transfer element 40 is at the desired location in the feeding artery, such as the internal carotid artery, refrigerant flow is commenced. As the expanding refrigerant cools the heat transfer element down, the heat transfer element 40 takes on the double helical shape shown in Figure 6 or the looped coil shape shown in Figure 7. Both of these configurations enhance the heat transfer capacity, while limiting the length of the heat transfer element 40.

As shown in Figures 8 through 11, the heat transfer element 24 can have external fins 46, 48 attached thereto, such as by welding or brazing, to promote heat transfer. Use of such fins allows the use of a shorter heat transfer element without reducing the heat transfer surface area, or increases the heat transfer surface area for a given length. In Figures 8 and 9, a plurality of longitudinal fins 46 are attached to the heat transfer element 24. The heat transfer element 24 in such an embodiment can have a diameter of approximately 1.0 millimeter, while each of the fins 46 can have a width of approximately 0.5 millimeter and a thickness of approximately 0.12 millimeter. This will give the heat transfer element an overall diameter of approximately 2.0 millimeters, still allowing the catheter to be inserted into the internal carotid artery.

In Figures 10 and 11, a plurality of annular fins 48 are attached to the heat transfer element 24. The heat transfer element 24 in such an embodiment can have a diameter of approximately 1.0 millimeter, while each of the fins 48 can have a width of approximately 0.5 millimeter and a thickness of approximately 0.12 millimeter. This will give the heat transfer element an overall diameter of approximately 2.0 millimeters, still allowing the catheter to be inserted into the internal carotid artery.

While the particular invention as herein shown and disclosed in detail is fully capable of obtaining the objects and providing the advantages hereinbefore stated, it is to be understood that this disclosure is merely illustrative of the presently preferred

WO 99/37226

PCT/US99/01275

embodiments of the invention and that no limitations are intended other than as described in the appended claims.

CLAIMS

I claim:

- 1 1. An apparatus for selective organ hypothermia, said apparatus
2 comprising:
3 a compressor;
4 a flexible elongated catheter, said catheter having a flexible tubular catheter
5 body;
6 a flexible tubular refrigerant supply conduit within said catheter body, a
7 proximal end of said refrigerant supply conduit being connected in
8 fluid flow communication with an outlet of said compressor;
9 a refrigerant return path within said catheter body, a proximal end of said
10 refrigerant return path being connected in fluid flow communication
11 with an inlet of said compressor;
12 an expansion element adjacent to a distal end of said catheter body, said
13 expansion element having an inlet at a distal end of said refrigerant
14 supply conduit;
15 a flexible heat transfer element mounted to said distal end of said catheter
16 body; and
17 a refrigerant chamber within said heat transfer element, said refrigerant
18 chamber being connected in fluid flow communication with an outlet
19 of said expansion element, said refrigerant chamber being connected in
20 fluid flow communication with a distal end of said refrigerant return
21 path within said catheter body.
- 1 2. An apparatus as recited in claim 1, further comprising a condenser
2 connected in fluid flow communication with said outlet of said compressor, wherein
3 said refrigerant supply conduit carries a liquid refrigerant to said expansion element.

1 3. An apparatus as recited in claim 1, wherein:
2 said refrigerant supply conduit is substantially coaxial with said catheter body;
3 and
4 said refrigerant return path surrounds said refrigerant supply conduit.

1 4. An apparatus as recited in claim 1, wherein said expansion element is a
2 capillary tube.

1 5. An apparatus as recited in claim 4, wherein said capillary tube is an
2 integral portion of said refrigerant supply conduit.

1 6. An apparatus as recited in claim 1, wherein said expansion element is
2 an orifice.

1 7. An apparatus as recited in claim 1, wherein said heat transfer element
2 comprises a hollow tube of material conducive to heat transfer.

1 8. An apparatus as recited in claim 7, further comprising at least one fin
2 of heat conducive material attached to said hollow tubular heat transfer element.

1 9. An apparatus as recited in claim 8, wherein said at least one fin
2 comprises a longitudinal fin.

1 10. An apparatus as recited in claim 8, wherein said at least one fin
2 comprises an annular fin.

1 11. An apparatus as recited in claim 1, wherein said heat transfer element
2 comprises a straight but flexible hollow tube constructed to transform to a hollow
3 coiled tube upon a temperature change in said heat transfer element.

1 12. An apparatus as recited in claim 1, wherein said heat transfer element
2 comprises a plurality of hollow tubes leading from said expansion element to said
3 refrigerant return path in said catheter body, said hollow tubes being outwardly
4 expandable.

1 13. An apparatus as recited in claim 1, wherein said heat transfer element
2 is constructed to transform to a hollow tube coiled around said refrigerant supply
3 conduit, upon a temperature change in said heat transfer element.

1 14. An apparatus as recited in claim 1, wherein said heat transfer element
2 comprises a hollow tube in the form of a loop having two sides, said loop being
3 constructed to transform to a double helix upon a temperature change in said heat
4 transfer element.

1 15. An apparatus as recited in claim 1, wherein said heat transfer element
2 comprises a hollow tube in the form of a loop having two sides, each side of said loop
3 being constructed to transform to a coil upon a temperature change in said heat
4 transfer element.

1 16. A method for selective organ hypothermia, said method comprising:
2 providing a flexible catheter, said catheter having an expansion element and a
3 hollow flexible heat transfer element adjacent its distal tip;
4 inserting said catheter through the vascular system of a patient to place said
5 heat transfer element in a feeding artery of a selected organ;
6 supplying compressed refrigerant to said expansion element;
7 expanding said refrigerant through said expansion element to cool the interior
8 of said hollow heat transfer element;
9 cooling blood flowing in said feeding artery with said heat transfer element, to
10 enable said blood to flow distally into said selected organ and cool said
11 organ.

1 17. A method as recited in claim 16, further comprising condensing said
2 compressed refrigerant prior to supplying said refrigerant to said expansion element.

1 18. A method as recited in claim 16, further comprising;
2 forming said heat transfer element as a hollow tube; and
3 creating a temperature change in said heat transfer element to transform said
4 heat transfer element to a hollow coiled tube.

1 19. A method as recited in claim 16, further comprising;
2 forming said heat transfer element as a hollow tube; and
3 creating a temperature change in said heat transfer element to transform said
4 heat transfer element to a hollow tube coiled around said refrigerant
5 supply conduit.

1 20. A method as recited in claim 16, further comprising:
2 forming said heat transfer element as a hollow tube in the form of a loop
3 having two sides; and
4 creating a temperature change in said heat transfer element to transform said
5 loop to a double helix.

1 21. A method as recited in claim 16, further comprising:
2 forming said heat transfer element as a hollow tube in the form of a loop
3 having two sides; and
4 creating a temperature change in said heat transfer element to transform each
5 said side of said loop to a coil.

1 22. A method as recited in claim 16, wherein said heat transfer element
2 comprises a plurality of hollow tubes leading from said expansion element to a
3 refrigerant return path in said catheter, said method further comprising expanding said
4 plurality of hollow tubes outwardly.

AMENDED CLAIMS

[received by the International Bureau on 28 May 1999 (28.05.99);
new claims 23-25 added; remaining claims unchanged (2 pages)]

1 23. A method of selectively inducing at least partial hypothermia in an organ
2 of a patient, comprising:
3 providing a catheter with a flexible metallic heat transfer element disposed at a
4 distal end thereof;
5 inserting the catheter and heat transfer element into the vascular system of a
6 patient to place at least a portion of the heat transfer element in a feeding
7 artery of an organ;
8 circulating a working fluid through the catheter and through the heat transfer
9 element to lower the temperature of the heat transfer element;
10 cooling blood in the feeding artery by contact with the cooled heat transfer
11 element; and
12 cooling the organ by flow of the cooled blood through the feeding artery while
13 maintaining the core body temperature at a substantially constant level.

1 24. A method of selectively inducing at least partial hypothermia in an organ
2 of a patient, comprising:
3 providing a catheter with a flexible metallic heat transfer element disposed at a
4 distal end thereof;
5 inserting the catheter and heat transfer element into the vascular system of a
6 patient to place at least a portion of the heat transfer element in a feeding
7 artery of an organ;
8 circulating a working fluid through the catheter and through the heat transfer
9 element to lower the temperature of the heat transfer element;
10 cooling blood in the feeding artery by contact with the cooled heat transfer
11 element; and
12 cooling the organ by flow of the cooled blood through the feeding artery such
13 that the organ temperature decreases substantially prior to reduction of the
14 core body temperature.

1 25. A method of selectively inducing at least partial hypothermia in an organ
2 of a patient, comprising:
3 providing a catheter with a flexible metallic heat transfer element disposed at a
4 distal end thereof;
5 inserting the catheter and heat transfer element into the vascular system of a
6 patient to place at least a portion of the heat transfer element in a feeding
7 artery of an organ;
8 circulating a working fluid through the catheter and through the heat transfer
9 element to lower the temperature of the heat transfer element; and
10 cooling blood in the feeding artery by contact with the cooled heat transfer
11 element.

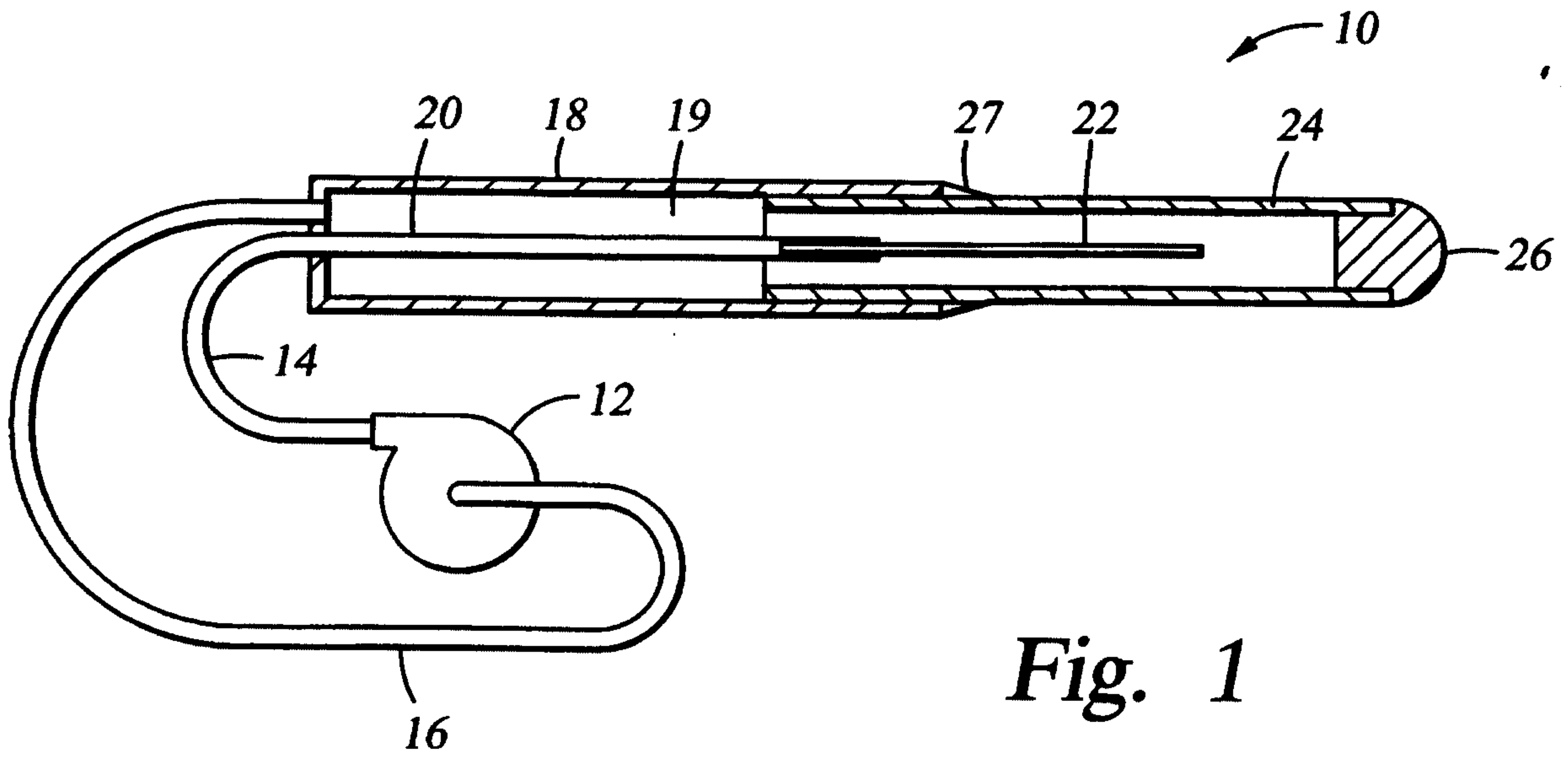

Fig. 1

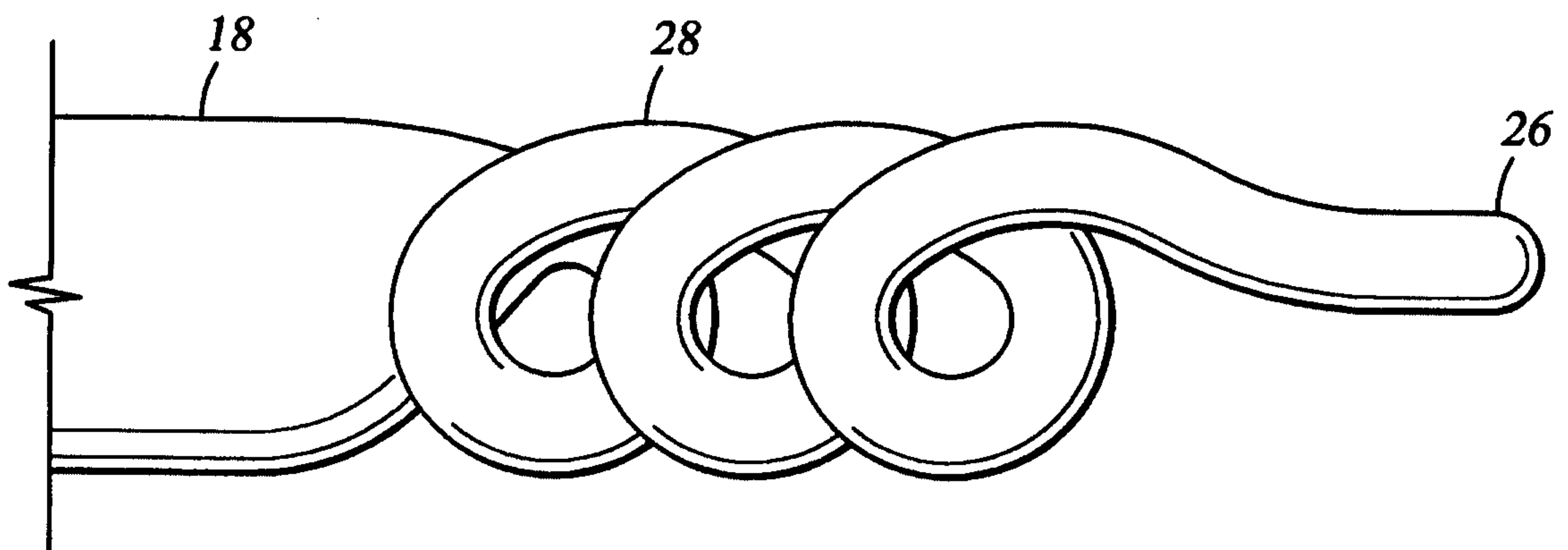

Fig. 2

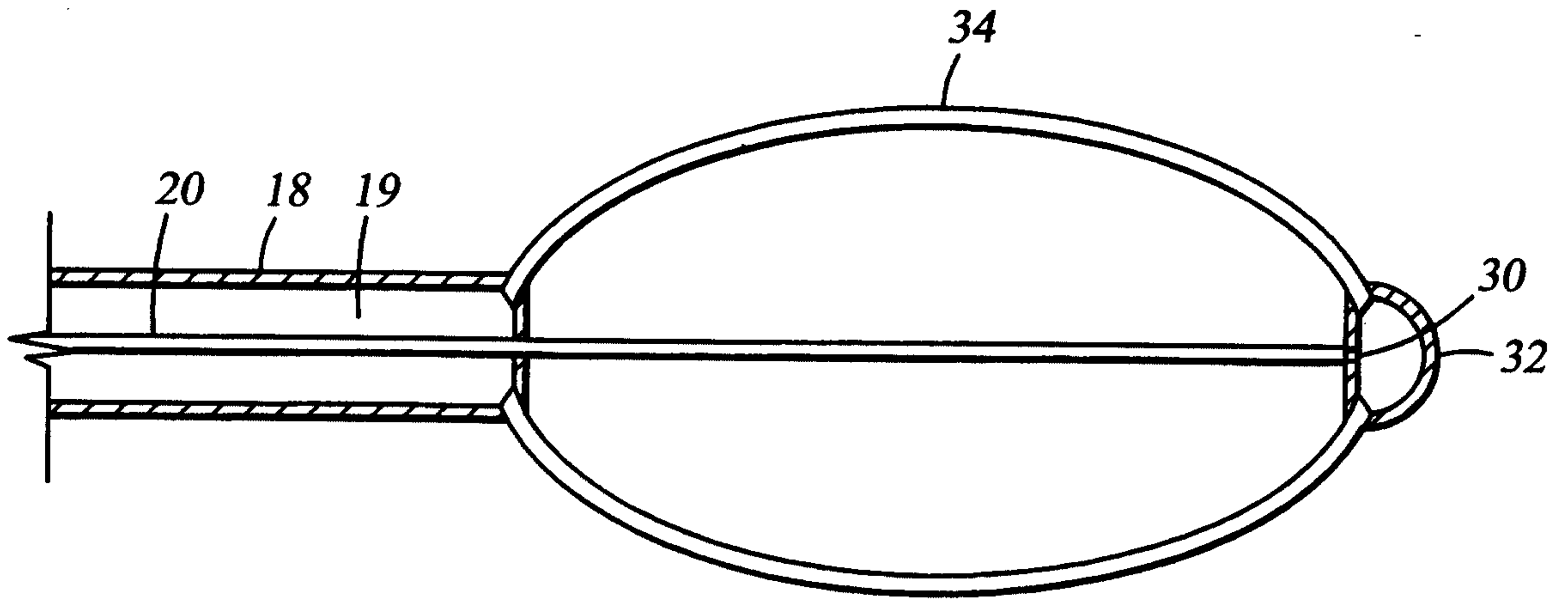

Fig. 3

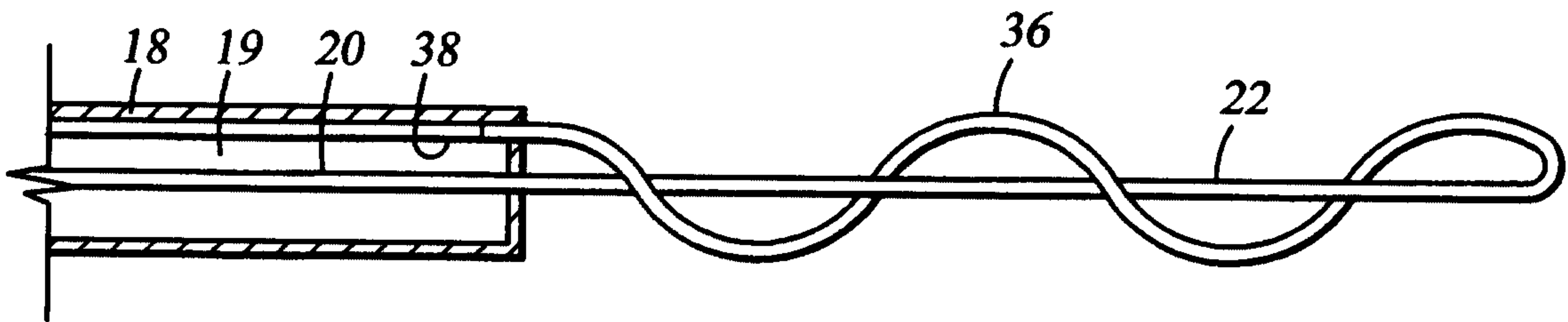

Fig. 4

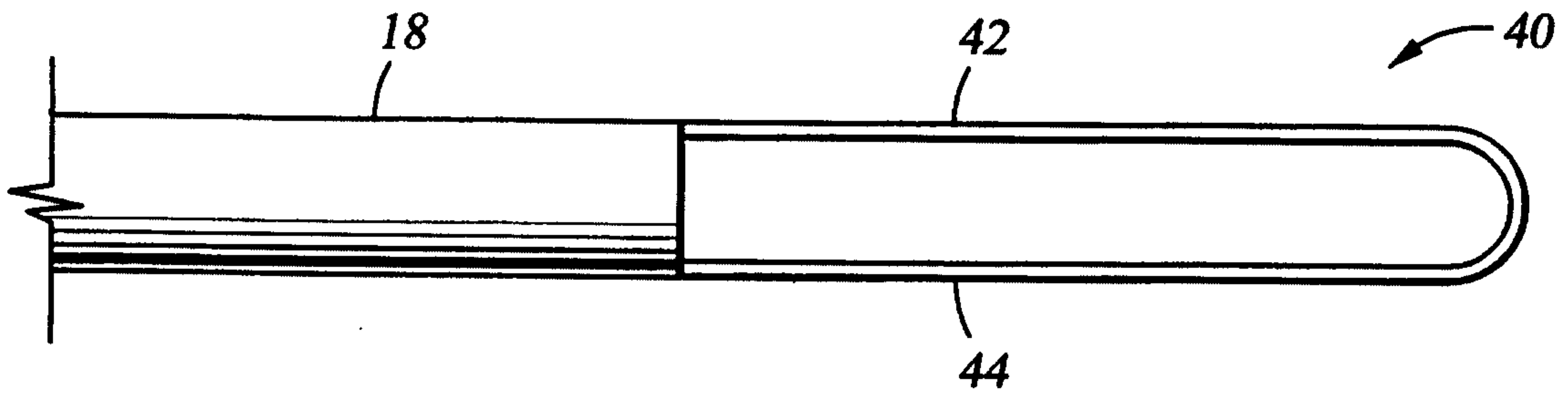

Fig. 5

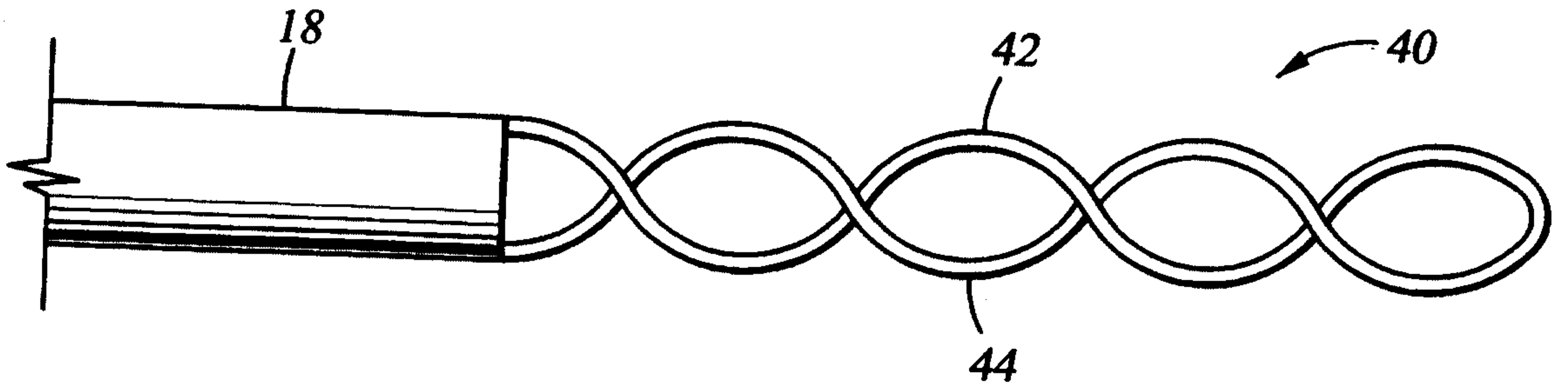

Fig. 6

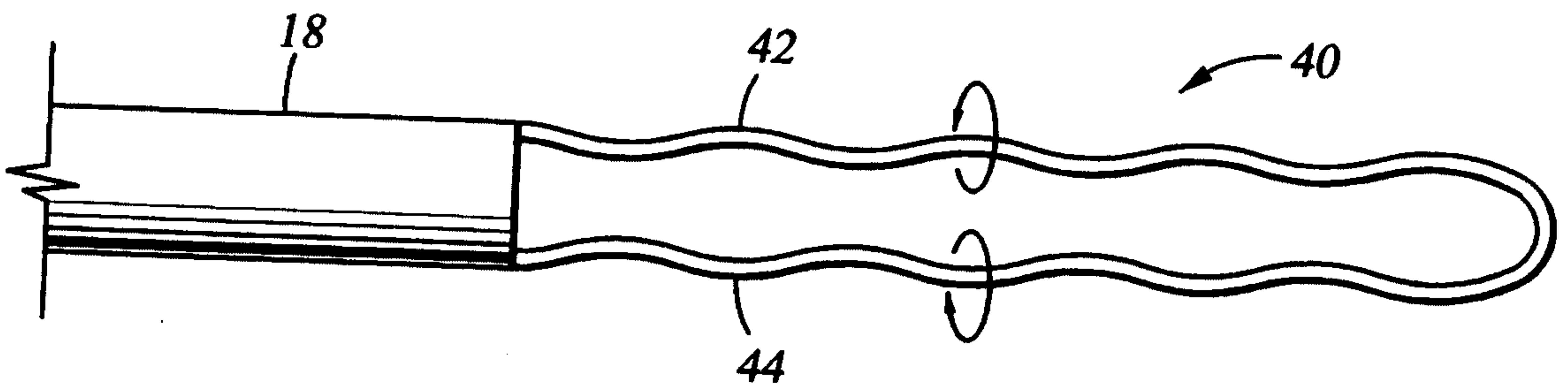

Fig. 7

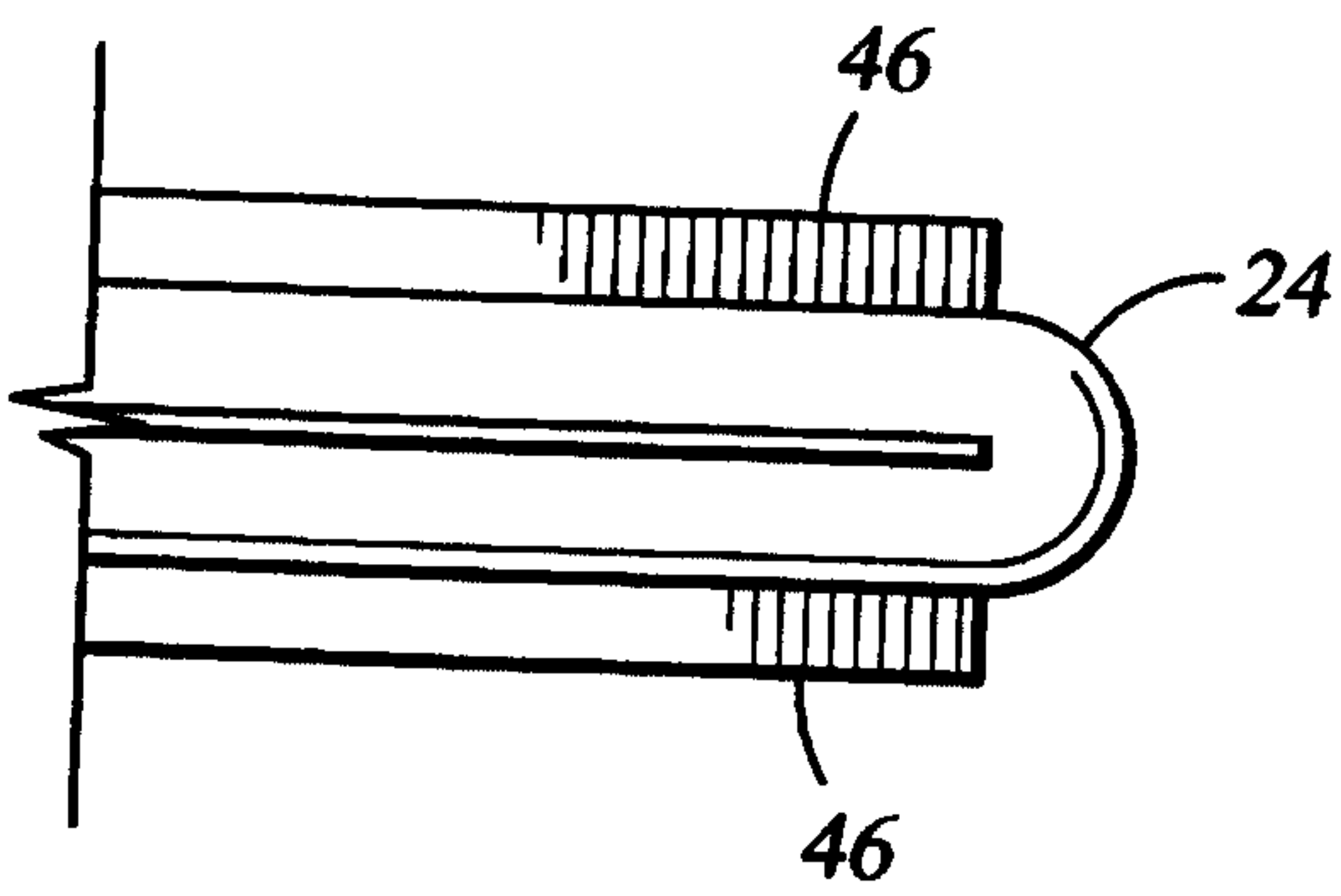

Fig. 8

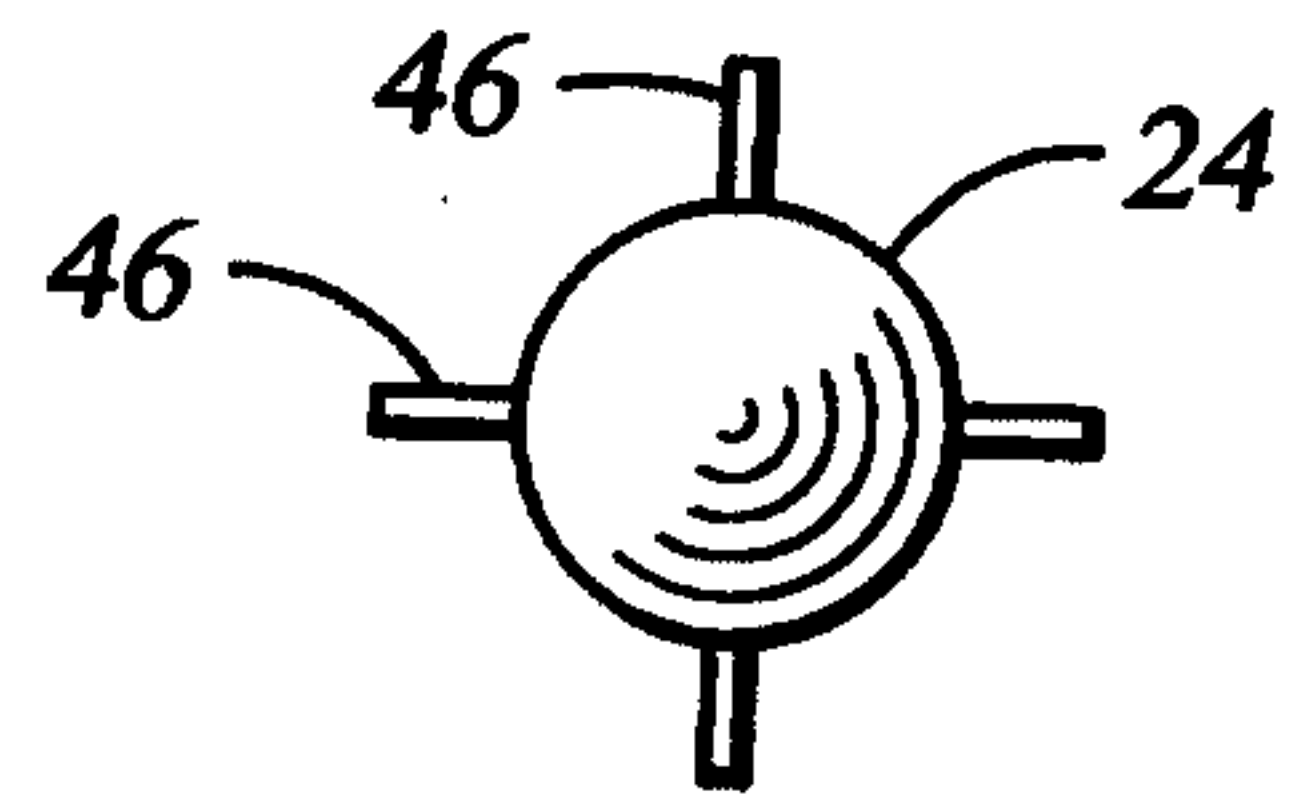

Fig. 9

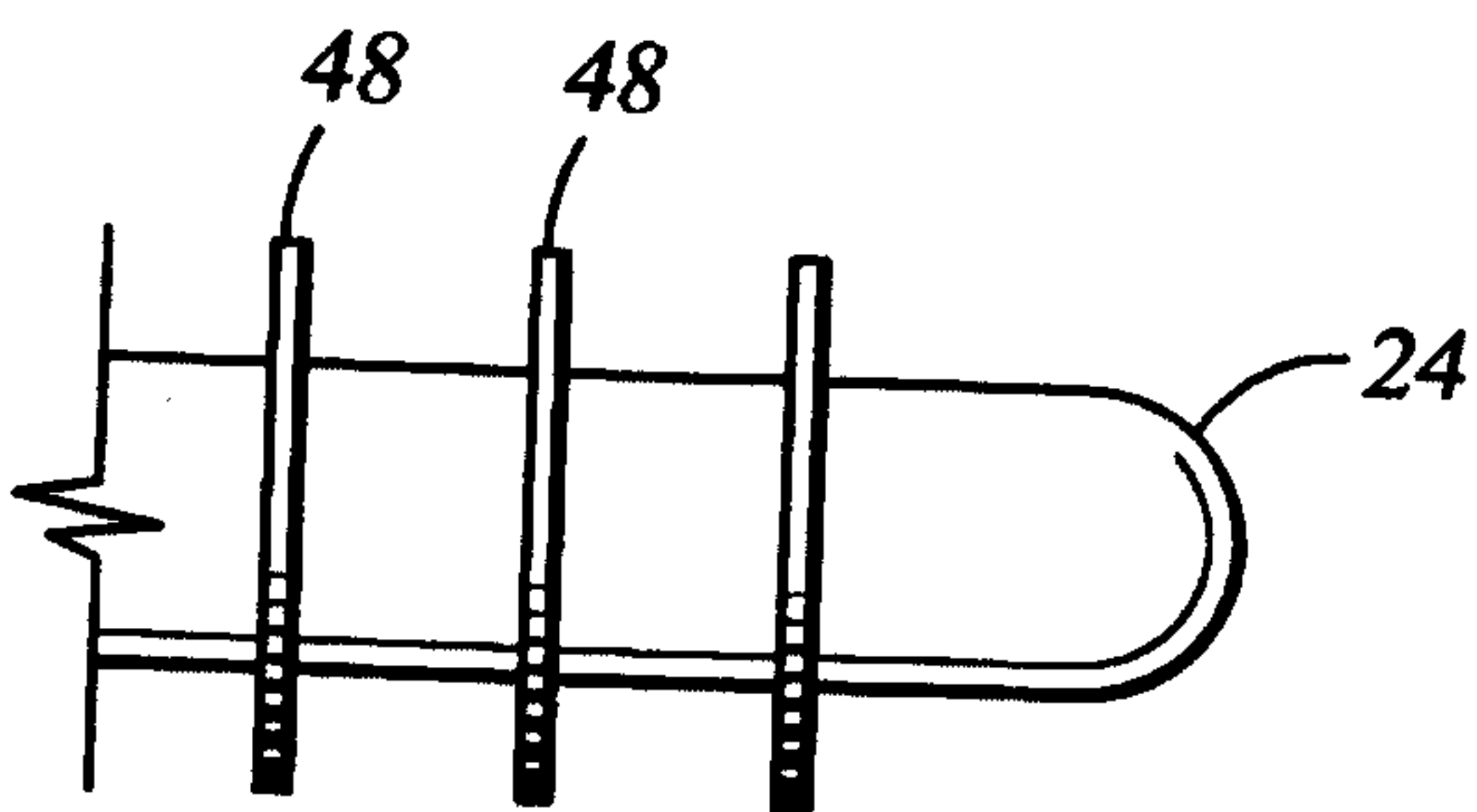

Fig. 10

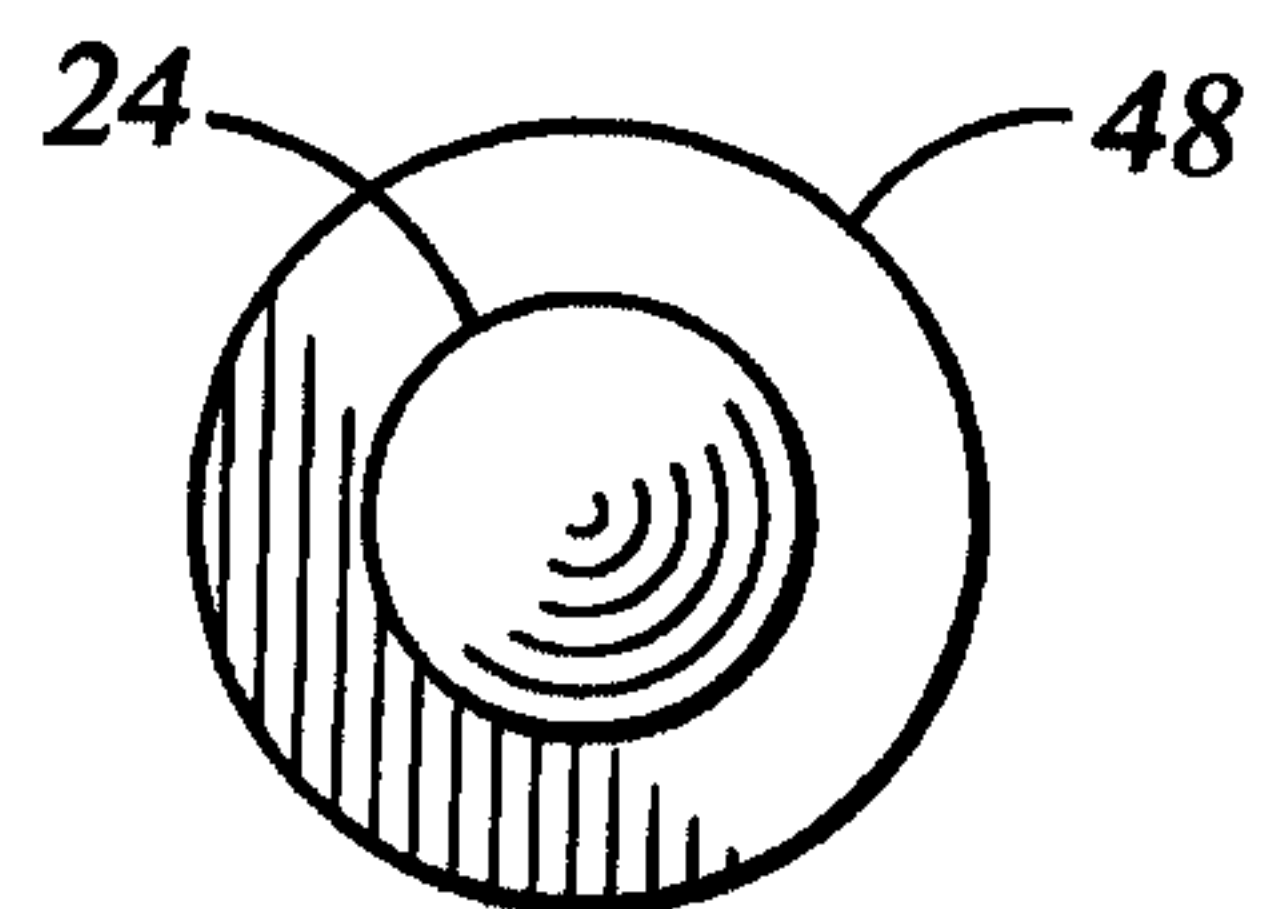

Fig. 11

