



- (51) International Patent Classification:
A61F 2/24 (2006.01)
- (21) International Application Number:
PCT/US2017/021709
- (22) International Filing Date:
10 March 2017 (10.03.2017)
- (25) Filing Language: English
- (26) Publication Language: English
- (30) Priority Data:
15/067,232 11 March 2016 (11.03.2016) US
- (71) Applicant: MEDTRONIC VASCULAR INC. [US/US];
3576 Unocal Place, Santa Rosa, CA 95003 (US).
- (72) Inventors: SANDSTROM, Jeffrey; c/o IP Legal Department,
Medtronic Vascular Inc., 3576 Unocal Place, Santa
Rosa, CA 95403 (US). VAUGHAN, Brendan; c/o IP Leg-
al Department, Medtronic Vascular Inc., 3576 Unocal
Place, Santa Rosa, CA 95403 (US).
- (74) Agent: HAYNES, William, H.; c/o IP Legal Department,
Medtronic Vascular Inc., 3576 Unocal Place, Santa Rosa,
CA 95403 (US).

- (81) Designated States (unless otherwise indicated, for every kind of national protection available): AE, AG, AL, AM, AO, AT, AU, AZ, BA, BB, BG, BH, BN, BR, BW, BY, BZ, CA, CH, CL, CN, CO, CR, CU, CZ, DE, DJ, DK, DM, DO, DZ, EC, EE, EG, ES, FI, GB, GD, GE, GH, GM, GT, HN, HR, HU, ID, IL, IN, IR, IS, JP, KE, KG, KH, KN, KP, KR, KW, KZ, LA, LC, LK, LR, LS, LU, LY, MA, MD, ME, MG, MK, MN, MW, MX, MY, MZ, NA, NG, NI, NO, NZ, OM, PA, PE, PG, PH, PL, PT, QA, RO, RS, RU, RW, SA, SC, SD, SE, SG, SK, SL, SM, ST, SV, SY, TH, TJ, TM, TN, TR, TT, TZ, UA, UG, US, UZ, VC, VN, ZA, ZM, ZW.
- (84) Designated States (unless otherwise indicated, for every kind of regional protection available): ARIPO (BW, GH, GM, KE, LR, LS, MW, MZ, NA, RW, SD, SL, ST, SZ, TZ, UG, ZM, ZW), Eurasian (AM, AZ, BY, KG, KZ, RU, TJ, TM), European (AL, AT, BE, BG, CH, CY, CZ, DE, DK, EE, ES, FI, FR, GB, GR, HR, HU, IE, IS, IT, LT, LU, LV, MC, MK, MT, NL, NO, PL, PT, RO, RS, SE, SI, SK, SM, TR), OAPI (BF, BJ, CF, CG, CI, CM, GA, GN, GQ, GW, KM, ML, MR, NE, SN, TD, TG).

Published:

— with international search report (Art. 21(3))

(54) Title: DELIVERY DEVICE FOR PROSTHETIC HEART VALVE WITH CAPSULE ADJUSTMENT DEVICE

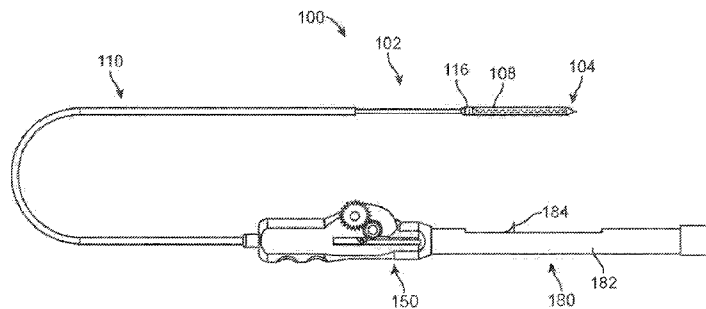
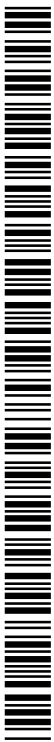

FIG. 3

(57) Abstract: A delivery device for percutaneously delivering a stented prosthetic heart includes a sheath, a handle, and adjustment device including a fine adjustment mechanism, and an outer stability shaft. The sheath defines a lumen and is configured to compressively constrain the stented prosthetic heart valve. The handle is coupled to the proximal portion of the sheath and includes an actuator mechanism coupled to a proximal portion of the sheath that is configured to selectively move the sheath relative to the housing to release the stented prosthetic heart valve. The adjustment device is coupled to the handle and includes an adjustment lumen through which the sheath and the handle slidably extend. The outer stability shaft is coupled to the adjustment device. The fine adjustment mechanism is configured to selectively move the handle and the sheath relative to the adjustment device and the outer stability shaft.



DELIVERY DEVICE FOR PROSTHETIC HEART VALVE WITH CAPSULE ADJUSTMENT DEVICE

CROSS-REFERENCE TO RELATED APPLICATIONS

[0001] The present application is a continuation-in-part of U.S. Patent Application No. 14/656,838 filed March 13, 2015, the contents of which are incorporated by reference herein in their entirety.

FIELD OF THE INVENTION

[0002] The present invention relates to systems and methods for percutaneous implantation of a prosthetic heart valve. More particularly, it relates to the systems and methods for the fine adjustment and placement of a stented prosthetic heart valve via transcatheter implantation.

BACKGROUND

[0003] Heart valves are sometimes damaged by disease or by aging, resulting in problems with the proper functioning of the valve. Heart valve replacement has become a routine surgical procedure for patients suffering from valve dysfunctions. Traditional open surgery inflicts significant patient trauma and discomfort, requires extensive recuperation times, and may result in life-threatening complications.

[0004] To address these concerns, efforts have been made to perform cardiac valve replacements using minimally-invasive techniques. In these methods, laparoscopic instruments are employed to make small openings through the patient's ribs to provide access to the heart. While considerable effort has been devoted to such techniques, widespread acceptance has been limited by the clinician's ability to access only certain regions of the heart using laparoscopic instruments.

[0005] Still other efforts have been focused upon percutaneous transcatheter (or transluminal) delivery of replacement cardiac valves to solve the problems presented by traditional open surgery and minimally-invasive surgical methods. In such methods, a valve prosthesis is compacted for delivery in a catheter and then advanced, for example through an opening in the femoral artery, and through the descending aorta to the heart, where the prosthesis is then deployed in the valve annulus (e.g., the aortic valve annulus).

[0006] Various types and configurations of prosthetic heart valves are available for percutaneous valve replacement procedures. In general, prosthetic heart valve designs attempt to replicate the function of the valve being replaced and thus will include valve leaflet-like structures. Valve prostheses are generally formed by attaching a bioprosthetic valve to a frame made of a wire or a network of wires. Such a valve prosthesis can be contracted radially to introduce the valve prosthesis into the body of the patient percutaneously through a catheter. The valve prosthesis can be deployed by radially expanding it once positioned at the desired target site.

[0007] In addition to the delivery device itself, typical transcatheter heart implantation techniques entail the use of a separate introducer device to establish a portal to the patient's vasculature (e.g., femoral artery) and through which the prosthetic valve-loaded delivery device is inserted. The introducer device generally includes a relatively short sheath and a valve structure. By inserting the prosthetic heart valve-loaded sheath through the introducer valve and sheath, a low friction hemostasis seal is created around the outer surface of the delivery sheath. While highly desirable, friction between the introducer device and the delivery sheath can be problematic, leading to unexpected movement of the prosthesis prior to release from the delivery device. If the deployed prosthesis is incorrectly positioned relative to the native annulus, serious complication may arise including paravalvular leakage (PVL) or the requirement for placement of a permanent pacemaker.

[0008] For example, FIG. 1A illustrates, in simplified form, an introducer device 10 establishing a portal to a patient's vasculature 12, and through which a prosthetic heart valve-loaded delivery shaft 14 has been inserted. As shown, delivery shaft 14 has been manipulated to locate the loaded prosthetic heart valve 16 (generally referenced) near a desired position relative to an aortic valve 18. An outer delivery sheath 20 contains the prosthetic heart valve 16. However, it is not always possible to accurately position the delivery device containing the prosthetic heart valve 16 at the desired position. Accordingly, adjustments in the position must be made. Conventionally, adjusting the position of the prosthetic heart valve 16 is accomplished by moving handle 22 proximally or distally. In the example of FIG. 1B, handle 22 is moved proximally. However, as handle 22 is moved proximally, outer delivery sheath 20 pulls towards the inner wall of the descending aorta 29 and away from outer wall of aortic arch 28. With this movement, handle 22 has moved, but prosthetic heart valve 16 has not moved relative to aortic valve 18. Thus, it takes more movement of handle 22 to move prosthetic heart

valve 22. Further, the location of prosthetic heart valve 16 often needs to be adjusted a very small amount, which is difficult to accomplish by pushing or pulling handle 22.

[0009] Accordingly, there is a need for an improved adjustment mechanism and method to more accurately position a prosthetic heart valve implanted via transcatheter delivery devices and methods.

SUMMARY OF THE INVENTION

[0010] Embodiments hereof relate to a delivery device for percutaneously delivering a stented prosthetic heart valve to the site of a damaged or diseased native valve. The stented prosthetic heart valve is radially expandable from a radially compressed configuration to a radially expanded configuration. The delivery device includes a sheath, a handle, and adjustment device including a fine adjustment mechanism, and an outer stability shaft. The sheath defines a lumen and is configured to compressively constrain the stented prosthetic heart valve. The handle is coupled to the proximal portion of the sheath and includes an actuator mechanism coupled to a proximal portion of the sheath that is configured to selectively move the sheath relative to the housing to release the stented prosthetic heart valve. The adjustment device is coupled to the handle and includes an adjustment lumen through which the sheath and the handle slidably extend. The outer stability shaft is coupled to the adjustment device. The fine adjustment mechanism is configured to selectively move the handle and the sheath relative to the adjustment device and the outer stability shaft.

[0011] Embodiments hereof also relate to a method for restoring a defective heart valve in a patient. The method includes manipulating a delivery device to guide a prosthetic heart valve through a patient's vasculature and into the defective heart valve by moving a handle of the delivery device. The delivery device is loaded with a prosthetic heart valve in a radially compressed configuration, the prosthetic heart including a stent frame to which a valve structure is attached. The delivery device includes a delivery sheath, an outer stability shaft, a handle, and an adjustment device. The sheath constrains the prosthetic heart valve in the radially compressed configuration. The outer stability shaft is coaxially received over the delivery sheath and terminates proximal of the prosthetic heart valve when the delivery device is in the delivery configuration. The handle includes a housing and an actuating mechanism coupled to the delivery sheath. The adjustment device is coupled to the handle. Moving the handle causes the adjustment device, delivery sheath, and the outer stability shaft to move. The location

of the prosthetic heart valve within the defective heart valve is finely adjusted by manipulating the fine adjustment mechanism of the adjustment device. Manipulating the fine adjustment mechanism causes the handle and the delivery sheath to move relative to the adjustment device and the outer stability shaft. The delivery sheath is withdrawn from the prosthetic heart valve by actuating the actuator mechanism such that the delivery sheath slides relative to the outer stability shaft and the handle to release the prosthetic heart valve from the delivery sheath. With the release of the prosthetic heart valve from the delivery sheath, the prosthetic heart valve self-expands into engagement with the native heart valve.

BRIEF DESCRIPTION OF DRAWINGS

[0012] FIGS. 1A-1B are simplified illustrations of conventional transcatheter delivery of a stented prosthetic heart valve.

[0013] FIG. 2A is a side illustration of a stented prosthetic heart valve useful with systems, devices, and methods of the present disclosure and in a normal, expanded configuration.

[0014] FIG. 2B is a side illustration of the prosthetic heart valve of FIG. 2A in a radially compressed configuration.

[0015] FIG. 3 is a side illustration of the delivery device of the present disclosure.

[0016] FIG. 4 is a cutaway illustration of an adjustment device of the delivery device of FIG. 3.

[0017] FIG. 5 is an exploded perspective illustration of the delivery device of FIG. 3.

[0018] FIG. 6 is a cutaway illustration of the delivery device of FIG. 3.

[0019] FIGS. 7A-7E are illustrations of the adjustment of the location of a capsule of the delivery device of FIG. 3.

[0020] FIGS. 8A-8B are simplified illustrations of a method of adjusting the location of a stented prosthetic heart valve during transcatheter delivery using the delivery device of FIG. 3.

[0021] FIG. 9 is a side illustration of another embodiment of the delivery device of the present disclosure.

[0022] FIG. 10 is a cutaway illustration of an adjustment device of the delivery device of FIG. 9.

[0023] FIG. 10A is a close-up view of the adjustment device of FIG. 10.

[0024] FIG. 11 is an exploded perspective illustration of the delivery device of FIG. 9.

[0025] FIG. 12 is a cutaway illustration of the delivery device of FIG. 9.

[0026] FIG. 12A is a schematic cross-sectional view of a portion of the delivery device of FIG. 9.

[0027] FIGS. 13A-13E are illustrations of the adjustment of the location of a capsule of the delivery device of FIG. 9.

DETAILED DESCRIPTION

[0028] Specific embodiments of the present invention are now described with reference to the figures, wherein like reference numbers indicate identical or functionally similar elements. The terms “distal” and “proximal”, when used in the following description to refer to a catheter or delivery device, are with respect to a position or direction relative to the treating clinician. Thus, “distal” and “distally” refer to positions distant from, or in a direction away from, the clinician and “proximal” and “proximally” refer to positions near, or in a direction toward, the clinician.

[0029] The following detailed description is merely exemplary in nature and is not intended to limit the invention or the application and uses of the invention. Furthermore, there is no intention to be bound by any expressed or implied theory presented in the preceding technical field, background, brief summary, or the following detailed description.

[0030] As referred to herein, the stented prosthetic heart valves used in accordance with and/or as part of the various systems, devices, and methods of the present disclosure may include a wide variety of different configurations, such as a bioprosthetic heart valve having tissue leaflets or a synthetic heart valve having polymeric, metallic, or tissue-engineered leaflets, and can be specifically configured for replacing any heart valve.

[0031] In general terms, the stented prosthetic heart valve of the present disclosure includes a stent supporting a valve structure (tissue or synthetic), with the stent having a normal, expanded configuration that is collapsible to a compressed configuration for loading within a delivery device. The stent is usually constructed to self-deploy or expand when released from the delivery device. For example, the stented prosthetic heart valve useful with the present disclosure can be a prosthetic heart valve sold under the trade name CoreValve® available from Medtronic CoreValve, LLC. Other non-

limiting examples of the transcatheter heart valve prostheses useful with the systems, devices, and methods of the present disclosure are described in U. S. Patent Nos. 7,662,186; and 7,740,655, which are incorporated in their entirety by reference herein. The stents or stent frames are support structures that comprise a number of struts or wire portions arranged relative to each other to provide a desired compressibility and strength to the prosthetic heart valve. In general terms, the stents or stent frames of the present disclosure are generally tubular support structures having an internal area in which valve structure leaflets will be secured.

[0032] With the above understanding in mind, one non-limiting example of a stented prosthetic heart valve 30 useful with systems, devices, and methods of the present disclosure is illustrated in FIG. 2A. As a point of reference, the prosthetic heart valve 30 is shown in a normal, pre-set, or expanded configuration in the view of FIG. 2A. FIG. 2B illustrates the prosthetic heart valve 30 in a compressed configuration (e.g., when compressively retained within an outer catheter or sheath). Prosthetic heart valve 30 includes a stent, or stent frame 32, and a valve structure 34. The valve structure 34 is assembled to stent frame 32 and provides two or more (typically three) leaflets 36. Stent frame 32 may assume differing forms and construction based upon application needs as described in greater detail in U.S. Patent No. 8,579,963, which is incorporated in its entirety by reference herein.

[0033] With the above understanding of the stented prosthetic heart valve 30 in mind, one embodiment of a delivery device 100, in accordance with the present disclosure, for percutaneously delivering and implanting a prosthetic heart valve 30, is shown in FIG. 3. Delivery device 100 may assume differing forms and construction based upon application needs as described in greater detail in U.S. Patent Nos. 8,579,963; 8,491,650; and 8,465,541, which are incorporated in their entirety by reference herein.

[0034] Delivery device 100 includes a handle 180, an adjustment device 150, an outer stability shaft 110, a delivery sheath assembly 102, and an inner shaft assembly 104 as shown in FIG. 3. Each of these components is described in greater detail below. Delivery device 100 is configured to be used for transcatheter valve implantation. Other embodiments of the delivery device and adjustment device are possible. Delivery device 100, described in greater detail below, is merely an exemplary embodiment of a transcatheter delivery device and modifications can be made to the embodiments described herein without departing from the spirit and scope of the present invention. Therefore, the following detailed description is not meant to be limiting. Further, the

systems and functions described below can be implemented in many different embodiments of hardware. Any actual hardware described is not meant to be limiting. The operation and behavior of the systems and methods presented are described with the understanding that modifications and variations of the embodiments are possible given the level of detail presented.

[0035] Components in accordance with the embodiment of delivery device 100 of FIG. 3 are presented in greater detail in FIGS. 4-6. Various features of the components of delivery device 100 reflected in FIGS. 4-6 and described below can be modified or replaced with differing structures and/or mechanisms. The present disclosure is in no way limited to delivery sheath assembly 102, inner shaft assembly 104, outer stability shaft 110, adjustment device 150, and handle 180 shown and described below. In more general terms, delivery devices in accordance with the principles of the present disclosure provide features capable of compressively retaining a self-expanding, stented prosthetic heart valve (e.g., the capsule 108), along with an mechanism and method for finely adjusting the position of a self-expanding, stented prosthetic heart valve (e.g., adjustment device 150) within a defective heart valve.

[0036] In the embodiment of FIGS. 4-6, delivery sheath assembly or sheath 102 includes a capsule 108 and a shaft 118, and defines a lumen 112 extending from a proximal end 130 to a distal end 132 of delivery sheath assembly 102. The length and thickness of capsule 108 are determined by the requirements of the specific application and are described in greater detail in U.S. Patent No. 8,579,963, previously incorporated by reference herein. Shaft 118 is configured for fixed connection to capsule 108 at connection point 116, and extends proximally from capsule 108, with shaft 118 configured for fixed connection of delivery sheath assembly 102 to handle 180. Although delivery sheath assembly 102 is described herein as including capsule 108 and shaft 118, capsule 108 may simply be an extension of shaft 118 and the delivery sheath assembly 102 may be described simply as sheath 102.

[0037] Inner shaft assembly 104 can assume a variety of configurations described in greater detail in U.S. Patent No. 8,579,963, previously incorporated by reference herein. In general, inner shaft assembly 104 includes a proximal inner shaft 114, a retention member 120, and a tip 121. Proximal inner shaft 114 connects to retention member 120, and retention member 120 connects to tip 121. Proximal inner shaft 114 is configured for fixed connection of inner shaft assembly 104 to handle 180. The components of inner shaft assembly 104 combine to define a continuous lumen 122,

which is sized to receive an auxiliary component such as a guide wire (not shown). Although inner shaft assembly 104 is described herein as including proximal inner shaft 114, retention member 120, and tip 121, retention member 120 and tip 121 may simply be an extension of proximal inner shaft 114 and the inner shaft assembly 104 may be described simply as inner shaft 104.

[0038] Outer stability shaft 110 can assume a variety of configurations described in greater detail in U.S. Patent No. 8,579,963, previously incorporated by reference herein. In general, outer stability shaft 110 is configured for fixed connection to adjustment device 150. Outer stability shaft 110 serves as a stability shaft for delivery device 100, and has a proximal end 124, a distal end 126, and a passageway 128 extending between ends 124 and 126. The passageway is sized to coaxially receive delivery sheath assembly 102, and in particular shaft 118, in a manner permitting the sliding of shaft 118 relative to outer stability shaft 110.

[0039] Handle 180 can assume a variety of configurations described in greater detail in U.S. Patent No. 8,579,963, previously incorporated by reference, and modified herein. In general, handle 180 includes a housing 182, an actuator mechanism 184, a handle extension 186, and teeth 188 on handle extension 186. Housing 182 retains actuator mechanism 184. Sheath 102 is coupled to actuator mechanism 184 such that movement of actuator mechanism 182 causes sheath 102 to move relative to outer stability shaft 110 and inner shaft assembly 104, as described below. Handle extension 186 extends from the distal end of housing 182.

[0040] In the embodiment of FIGS. 5-6, handle 180 provides a surface for convenient handling and grasping by a user, and can have a generally cylindrical shape as shown. While the handle of FIGS. 5-6 is shown with a cylindrical shape, it is not meant to limit the design, and other shapes and sizes are contemplated based on application requirements.

[0041] Handle 180 is configured to maintain portions of the actuator mechanism 184 within a cavity 183 defined by housing 182. In the embodiment shown in FIGS. 5-6, housing 180 further forms a longitudinal slot 185 through which actuator mechanism 184 extends for interfacing by a user. Handle extension 186 extends distally from housing 182 and provides a mounting surface for teeth 188. For example, and not by way of limitation, teeth 188 may be formed integrally as part of handle extension 186 or may be coupled to handle extension 186 by adhesives, welding, clamping, and other coupling devices as appropriate. While FIGS. 5-6 show teeth 188 located on one side

of handle extension 186, this is not meant to limit the design, and teeth 188 may be located elsewhere on handle extension 186.

[0042] Adjustment device 150, as shown in the embodiment of FIGS. 4-6, includes an adjustment housing 151, an adjustment mechanism 152, and an extension 160 at the distal end of adjustment device 150. The components of adjustment device 150 combine to define a continuous lumen 159 through adjustment device 150. The proximal portion of lumen 159 is configured to accept handle extension 186 of handle 180. A distal portion of lumen 159 defined by extension 160 is configured to accept the proximal end of outer stability shaft 110. Outer stability shaft 110 may be coupled to extension 160 by adhesives, welding, clamping, and other coupling devices, as appropriate.

[0043] Adjustment device 150 provides a surface for convenient handling and grasping by a user, and can have a generally cylindrical shape as shown. While adjustment device 150 of FIGS. 4-6 is shown with a cylindrical shape, it is not meant to limit the design, and other shapes and sizes are contemplated based on application requirements. Adjustment device 150 is configured to maintain portions of adjustment mechanism 152 within a cavity defined by housing 151. In the embodiment shown in FIG. 5, housing 151 further includes a longitudinal slot 161 through which adjustment mechanism 152 extends for interfacing by a user.

[0044] Adjustment mechanism 152 includes a first toothed wheel 154 and a second toothed wheel 158, as shown in FIGS. 4-6. First toothed wheel 154 has teeth 153. Second toothed wheel 158 has teeth 156. First toothed wheel 154 is disposed within housing 151 on a first pivot axis 155 such that first toothed wheel 154 rotates about first pivot axis 155. The upper radius of first toothed wheel 154 extends through longitudinal slot 161 in housing 151 for user interface. Second toothed wheel 158 is disposed within housing 151 on a second pivot axis 157 such that second toothed wheel 158 rotates about second pivot axis 157. Teeth 156 on second toothed wheel 158 are configured to engage with teeth 188 on handle extension 186, as described in more detail below. First toothed wheel 154 and second toothed wheel 158 are configured such that teeth 153 of first toothed wheel 154 engage with teeth 156 of second toothed wheel 158. While FIGS. 4-6 show adjustment mechanism 152 having a specific number of teeth 153 on first toothed wheel 154 and a specific number of teeth 156 on second toothed wheel 158, this is not meant to limit the design and the number of teeth 153 and 156 may assume other configurations.

[0045] Adjustment mechanism 152 is generally constructed to provide selective retraction/advancement of handle 180, delivery sheath assembly 102, and inner shaft assembly 104 relative to housing 151 of adjustment device 150 and outer stability shaft 110. Adjustment mechanism 152 can have a variety of constructions and/or devices capable of providing the desired user interface and the current embodiment shown in FIGS. 4-6 is not meant to limit the design, but rather provide an example of one possible embodiment. For example, other embodiments of adjustment device 152 may utilize only first toothed wheel 152 to engage teeth 188 on handle extension 186.

[0046] When delivery device 100 is assembled, handle extension 186 resides within the proximal portion of lumen 159 of adjustment device 150, and is configured such that teeth 188 on handle extension 186 engage teeth 156 of second toothed wheel 158 of adjustment device 150. Handle extension 186 is sized such that it may fit within lumen 159 of adjustment device 150 and retract/advance within lumen 159 with user actuation of adjustment mechanism 152 of adjustment device 150.

[0047] Actuator mechanism 184 is generally constructed to provide selective retraction/advancement of the delivery sheath assembly 102 and can have a variety of constructions and/or devices capable of providing the desired user interface. One example of an actuator mechanism 184 is further described in U.S. Patent No. 8,579,963, previously incorporated by reference herein.

[0048] Construction of delivery device 100 is reflected in FIGS. 5-6 and includes delivery sheath assembly 102 being coaxially and slidably disposed between inner shaft assembly 104 and outer stability shaft 110. FIG. 6 shows delivery device 100 in the delivery configuration, with a prosthetic heart valve in a radially compressed configuration loaded within capsule 108. As shown in FIG. 6, capsule 108 is coaxially disposed over retention member 120 of inner shaft assembly 104. Inner shaft assembly 104 is rigidly connected to housing 182. Delivery sheath assembly 102 is movably connected to housing 182 via actuator mechanism 184. Outer stability shaft 110 is rigidly connected to adjustment device 150, as described previously. Generally speaking, delivery sheath assembly 102 can be retracted in a proximal direction relative to inner shaft assembly 104, outer stability shaft 110, and housing 182 from the delivery configuration of FIG. 6 to a deployed configuration wherein capsule 108 is retracted proximally such that capsule 108 does not surround the prosthetic heart valve. This allows the prosthetic heart valve to radially expand for engagement with the native heart valve (not shown).

[0049] Inner shaft assembly 104 extends within lumen 112 of sheath 102. Proximal inner shaft 114 of inner shaft assembly 104 extends proximally through lumen 159 of adjustment device 150, continuing proximally through housing 182, and is rigidly connected to handle 180 such that lumen 122 provides access for auxiliary components (e.g., a guide wire) therein. Proximal inner shaft 114 may be coupled to handle 180, for example, and not by way of limitation, by adhesives, welding, clamping, and other coupling devices as appropriate. Inner shaft assembly 104 is fixed relative to handle 180.

[0050] Delivery sheath assembly 102 extends within passageway 128 of outer stability shaft 110. Shaft 118 of delivery sheath assembly 102 extends proximally through lumen 159 of adjustment device 150, continuing proximally into housing 182 of handle 180, and is rigidly connected to actuator mechanism 184 of handle 180. Shaft 118 may be coupled to actuator mechanism 184 by adhesives, welding, clamping, and other coupling devices as appropriate. Delivery sheath assembly 102 is movable relative to handle 180 and adjustment device 150 by actuator mechanism 184. However, if actuator mechanism 184 is not moved and handle 180 is moved, delivery sheath assembly 102 moves with handle 180, not relative to handle 180, as explained in more detail below.

[0051] Outer stability shaft 110 is disposed within distal portion of lumen 159 and is coupled to extension 160. For example, and not by way of limitation, outer stability shaft 110 may be coupled to extension 160 by adhesives, welding, clamping, and other coupling devices as appropriate. Although outer stability shaft 110 is described as being attached to extension 160, outer stability shaft 110 may be coupled to housing 151 of adjustment device 150, and extension 160 may be excluded. Outer stability shaft 110 extends distally from adjustment device 150, and encompasses a portion of the length of shaft 118, thus stabilizing at least a portion of shaft 118 without impeding sliding/transitioning of capsule 108 from the delivery configuration to the deployed configuration. Outer stability shaft 110 is fixed longitudinally relative to adjustment device 150.

[0052] With the above understanding of components in mind, operation and interaction of components of the present disclosure may be explained. FIG. 4 illustrates adjustment device 150. Adjustment mechanism 152 of adjustment device 150 is configured such that, as first toothed wheel 154 is rotated in a first direction, teeth 153 on first toothed wheel 154 engage with teeth 156 on second toothed wheel 158 such

that rotation of first toothed wheel 154 causes rotation of second toothed wheel 158 in a second direction opposite the first direction. Teeth 156 of second toothed wheel 158 engage teeth 188 on handle extension 186 such that handle extension 186, and thus handle 180, moves relative to housing 151 of adjustment device 150. Inner shaft assembly 104 and delivery sheath assembly 102, being coupled to handle 180, also move relative to housing 151 of adjustment device 150. The engagement of teeth 156 on second toothed wheel 158 with teeth 188 on handle extension 186 also translates the rotational movement of second toothed wheel 158 to longitudinal movement of handle extension 186.

[0053] Handle 180 resides partially within the proximal end of adjustment lumen 159 of adjustment housing 151 such that teeth 188 on handle extension 186 are oriented parallel to longitudinal axis LA of adjustment device 150. First toothed wheel 154 and second toothed wheel 158 are oriented relative to longitudinal axis LA such that rotation of first toothed wheel 154 is parallel to longitudinal axis LA (i.e., first pivot axis 155 is transverse to longitudinal axis LA). In the embodiment shown, second toothed wheel 158 is also oriented relative to longitudinal axis LA such that rotation of second toothed wheel 158 is parallel to longitudinal axis LA (i.e., second pivot axis 157 is transverse to longitudinal axis LA). Adjustment mechanism 154 is configured to selectively move handle 180, delivery sheath assembly 102, and inner shaft assembly 104 relative to housing 151 of adjustment device 150 and outer stability shaft 110 a distance in the range of 1-50 mm, preferably in the range of 10-40 mm, and most preferably in the range of 20-30 mm. up to 25.0 mm.

[0054] FIGS. 7A-7E schematically show delivery device 100 in operation. In FIGS. 7A-7E the exposed portion of first toothed wheel 154 is rotated in a first direction 200, towards the distal end of adjustment device 150. Adjustment mechanism 152 is configured such that, as toothed wheel 154 is rotated in first direction 200, teeth 153 on first toothed wheel 154 engage teeth 156 on second toothed wheel 158 to rotate second toothed wheel 158 in direction 202. Teeth 156 of second toothed wheel 158 engage teeth 188 on handle extension 186 such that handle extension 186, and thus handle 180, move in distal direction 204, while housing 151 of adjustment device 150 remains stationary. Delivery sheath assembly 102 and inner shaft assembly 104, being coupled to handle 180, also move in distal direction 204. Although FIGS. 7A-7E only show movement of first toothed wheel 154 in first direction 200, resulting movement of handle 180, inner shaft assembly 104, and delivery sheath assembly 102 in distal direction 204,

movement of first toothed wheel 154 in second direction 202 results in movement of second toothed wheel 158 in first direction 200, and movement of handle 180, inner shaft assembly 104, and delivery sheath assembly 102 in a proximal direction opposite distal direction 204. Movement direction, either distally or proximally, of handle 180, delivery sheath assembly 102, and inner shaft assembly 104, relative to housing 151 of adjustment device 150 is dependent upon the direction of rotation of first toothed wheel 154. Rotational direction of first toothed wheel 154 is selected by operator manipulation.

[0055] FIGS. 9-13E illustrate another embodiment of a delivery device 300 in accordance with the present disclosure. Delivery device 300 includes a handle 380, an adjustment device 350, an outer stability shaft 310, a delivery sheath assembly 302, and an inner shaft assembly 304, as shown in FIG. 9. Outer stability shaft 310, delivery sheath assembly 302, and inner shaft assembly 304 are similar to outer stability shaft 110, delivery sheath assembly 102, and inner shaft assembly 104 of delivery device 100, described previously. Handle 380 and adjustment device 350 are described in greater detail below.

[0056] Handle 380 can assume a variety of configurations described in greater detail in U.S. Patent No. 8,579,963, previously incorporated by reference herein. In general, handle 380 includes a housing 382, an actuator mechanism 384, a handle extension 386, and a pin 388 extending from handle extension 386. Housing 382 is configured to retain actuator mechanism 384 therein. Delivery sheath assembly 302 is coupled to actuator mechanism 384 such that movement of actuator mechanism 384 causes delivery sheath assembly 302 to move relative to outer stability shaft 310 and inner shaft assembly 304, similar to delivery sheath assembly 102, actuator mechanism 184, outer stability shaft 110, and inner shaft assembly 104, as previously described with respect to delivery device 100. While a particular actuator mechanism and location of such an actuator mechanism is described herein, other actuator mechanisms may be used and may be located on different portions of the delivery device, as appropriate.

[0057] In the embodiment of FIGS. 9-13E, handle 380 provides a surface for convenient handling and grasping by a user, and can have a generally cylindrical shape as shown. While the handle of FIGS. 9-13E is shown with a cylindrical shape, it is not meant to limit the design, and other shapes and sizes may be used.

[0058] In an embodiment, and as described previously with respect to handle 180, actuator mechanism 184, and cavity 183 of delivery device 100, handle 380 of delivery device 300 is configured to maintain portions of the actuator mechanism 384 within a

cavity 383 defined by housing 382. In the embodiment shown in FIGS. 9-13E, housing 382 further forms a longitudinal slot 385 through which actuator mechanism 384 extends for interfacing by a user. Handle extension 386 extends distally from housing 382 and provides a mounting surface for pin 388.

[0059] Pin 388 is a generally cylindrical shape and includes a first end 389. Pin 388 extends radially outward from an outer surface of handle extension 386 such that pin 388 is disposed generally perpendicular to longitudinal axis LA1 of delivery device 300. Pin 388 may be formed as an integral part of handle extension 386 or may be coupled to handle extension 386 by methods such as, but not limited to adhesives, welding, clamping, and other coupling methods as appropriate. While FIGS. 9-13E show pin 388 located on one side of handle extension 386, this is not meant to limit the design, and pin 388 may be located elsewhere on handle extension 386. Additionally, while pin 388 is shown in FIGS. 9-13E with a generally cylindrical shape, this is not meant to limit the design and different shapes for pin 388 suitable for purposes of the present disclosure may be utilized. While first end 389 of pin 388 is shown as a flat disc, this is not meant to limit the design and other shapes may be utilized, such as, but not limited to, conical, square, or any corresponding shape suitable for the purposes described herein.

[0060] Adjustment device 350, as shown in the embodiment of FIGS. 9-13E, includes an adjustment housing 351, an adjustment mechanism 352, and an extension 360 at a distal end 355 of adjustment device 350. The components of adjustment device 350 combine to define a continuous lumen 359 through adjustment device 350. A proximal portion 361 of lumen 359 is configured to accept handle extension 386 of handle 380. A distal portion of lumen 359, defined by extension 360 is configured to accept a proximal end 324 of outer stability shaft 310. Outer stability shaft 310 may be coupled to extension 360 by adhesives, welding, clamping, and other coupling devices, as appropriate.

[0061] Adjustment device 350 provides a surface for convenient handling and grasping by a user, and can have a generally cylindrical shape as shown. While adjustment device 350 of FIGS. 9-13E is shown with a cylindrical shape, it is not meant to limit the design, and other shapes and sizes may be used. While extension 360 is shown in FIGS. 9-13E with a cylindrical shape, this is not meant to limit the design and other shapes may be utilized including a tapered cone, or other shapes suitable for the purposes described herein.

[0062] Housing 351 of adjustment device 350 includes a proximal end 363 a distal end 364. As shown in FIGS. 10 and 10A, a proximal portion of housing 351 includes a recess or channel 366. Channel 366 is a recessed portion of an outer surface of housing 351 disposed between a proximal shoulder 370 and a distal shoulder 371. Channel 366 is configured to receive an adjustment ring 353 of adjustment mechanism 352 such that adjustment ring 353 may rotate about an outer surface 373 of housing 351 at channel 366 and such that adjustment ring 353 is prevented from moving proximally or distally by shoulders 370, 371, respectively. A longitudinal slot 354 is disposed through the wall of housing 351 at channel 366. Longitudinal slot is generally parallel to longitudinal axis LA1 of delivery device 300. Longitudinal slot 354 is a through-slot such that it extends from outer surface 373 of channel 366 inward towards longitudinal axis LA1 and into proximal portion 361 of lumen 359 of housing 351. Longitudinal slot 354 is configured to accept pin 388 of handle extension 386 therethrough.

[0063] Adjustment mechanism 352 includes adjustment ring 353, as shown in FIGS. 9-13E. Adjustment mechanism 352 is configured to provide selective retraction/advancement of handle 380, delivery sheath assembly 302, and inner shaft assembly 304 relative to housing 351 of adjustment device 350 and outer stability shaft 310. Adjustment mechanism 352 can have a variety of constructions and/or devices capable of providing the desired user interface and the current embodiment shown in FIGS. 9-13E is not meant to limit the design, but rather provide an example of one possible embodiment.

[0064] Adjustment ring 353 of adjustment mechanism 352 is a generally tubular configuration and includes a first end 367 and a second end 368. Adjustment ring 353 further includes a lumen 374 extending from first end 367 to second end 368. Adjustment ring 353 further includes a helical groove or thread 369 disposed on an inner surface of adjustment ring 353. As described above, adjustment ring 353 is disposed about an outer surface of housing 351 at channel 366 such that housing 351 is disposed within lumen 374 of adjustment ring 353, as shown in FIGS. 10A and 12A. Adjustment ring 353 is configured to rotate about housing 351. Adjustment ring 353 may include indentations 372 or other surface modifications on an outer surface thereof as a guide for a user or to assist a user to rotate of adjustment ring 353

[0065] Helical thread 369 may be of any suitable design corresponding to first end 389 of pin 388 of handle 380. Helical thread 369 of adjustment ring 353 is configured to engage first end 389 of pin 388 of handle 380 therein. Helical thread 369 may be

formed for example, and not by way of limitation, as an integral portion of adjustment ring 353 or separate unit coupled to adjustment ring 353 for example, and not by way of limitation, by adhesives, welding, or other methods as appropriate. While helical thread is shown in FIGS. 9-13E with a specific gender, handedness, thread form, thread angle, lead, pitch, and start, this is not meant to limit the design and other configurations and combinations may be utilized.

[0066] When delivery device 300 is assembled, handle extension 386 resides within proximal portion 361 of lumen 359 of adjustment device 350, and is configured such that pin 388 on handle extension 386 extends through longitudinal slot 354 of housing 351 and engages helical thread 369 of adjustment ring 353 of adjustment mechanism 352. Handle extension 386 is sized such that it may fit within proximal portion 361 of lumen 359 of adjustment device 350 and retract/advance within proximal portion 361 with user actuation of adjustment mechanism 352 of adjustment device 350. With delivery device 300 so assembled, rotational movement of adjustment ring 353 causes helical thread 369 to move along pin 388. However, adjustment ring 353 cannot travel longitudinally because it is limited by shoulders 370, 371. Further, pin 388 cannot rotate with adjustment ring 353 because pin 388 is disposed through longitudinal slot 354. Thus, when adjustment ring 353 is rotated, pin 388 moves longitudinally along longitudinal slot 354. Since pin 388 is attached to handle extension 386, handle extension 386, and thus handle 380, move longitudinally with pin 388. Thus, rotational movement of adjustment ring 353 is converted to translational or longitudinal movement of pin 388 and handle 380.

[0067] Delivery sheath assembly 302, inner shaft assembly 304, outer stability shaft 310, a capsule 308, housing 382, and actuator mechanism 384 of delivery device 300 are similar in construction and configuration to delivery device 100 with respect to delivery sheath assembly 102, inner shaft assembly 104, outer stability shaft 110, capsule 108, housing 182, and actuator mechanism 184, as previously described. Generally speaking, delivery sheath assembly 302 of delivery device 300 can be retracted in a proximal direction relative to inner shaft assembly 304, outer stability shaft 310, and housing 382. Stated another way, delivery sheath assembly 302 is coaxially and slidably disposed between inner shaft assembly 304 and outer stability shaft 310. Capsule 308 is coaxially disposed over retention member 320 of inner shaft assembly 304. Inner shaft assembly 304 is rigidly connected to housing 382. Delivery sheath

assembly 302 is movably connected to housing 382 via actuator mechanism 384. Outer stability shaft 310 is rigidly connected to adjustment device 350.

[0068] With the above understanding of components in mind, operation and interaction of components of the present embodiment may be explained. Adjustment mechanism 352 of adjustment device 350 is configured such that, as adjustment ring 353 is rotated in a first direction 400, helical thread 369 rotates with adjustment ring 353 and engages pin 388 such that rotation of adjustment ring 353 causes longitudinal movement of pin 388 disposed therein in a distal direction 400. Pin 388 moves longitudinally within longitudinal slot 354. Longitudinal movement of pin 388 translates longitudinal movement to handle extension 386 such that handle extension 386, and thus handle 380, moves relative to housing 351 of adjustment device 350. Inner shaft assembly 304 and delivery sheath assembly 302, being coupled to handle 380, also move relative to housing 351 of adjustment device 350. Stated another way, the engagement of helical thread 369 of adjustment ring 353 with pin 388 on handle extension 386 translates the rotational movement of adjustment ring 353 to longitudinal movement of handle 380, inner shaft 304, and delivery sheath assembly 302.

[0069] Handle 380 resides partially within proximal portion 361 of adjustment lumen 359 of adjustment housing 351 such that pin 388 on handle extension 386 is oriented radially outward and perpendicular to longitudinal axis LA1 of adjustment device 300. Longitudinal slot 354 of adjustment mechanism 352 is parallel to longitudinal axis LA1, and longitudinal movement of pin 388 is parallel to longitudinal axis LA1. Adjustment mechanism 352 is configured to selectively move handle 380, delivery sheath assembly 302, and inner shaft assembly 304 relative to housing 351 of adjustment device 350 and outer stability shaft 310 a distance in the range of 1-50 mm, preferably in the range of 10-40 mm, and most preferably in the range of 20-30 mm.

[0070] FIGS. 13A-13E schematically show delivery device 300 in operation. In FIGS. 13A-13E, adjustment ring 353 is rotated in first direction 400. Adjustment mechanism 352 is configured such that, as adjustment ring 353 is rotated in first direction 400, helical thread 369 rotates in first direction 400. Helical thread 369 of adjustment ring 353 engages pin 388 of handle extension 386 such that pin 388, handle extension 386, and thus handle 380, moves in a distal direction 404, while housing 351 of adjustment device 350 remains stationary. Delivery sheath assembly 302 and inner shaft assembly 304, being coupled to handle 380, also move in distal direction 404. Although FIGS. 13A-13E only show rotation of adjustment ring 353 in first direction 400, resulting in

movement of handle 380, inner shaft assembly 304, and delivery sheath assembly 302 in distal direction 404, rotation of adjustment ring 353 in a second direction 402, wherein second direction 402 is opposite first direction 400, results in rotational movement of helical thread 369 in second direction 402, and movement of handle 380, inner shaft assembly 304, and delivery sheath assembly 302 in a proximal direction 406. Movement direction, either distally or proximally, of handle 380, delivery sheath assembly 302, and inner shaft assembly 304, relative to housing 351 of adjustment device 350 is dependent upon the direction of rotation of adjustment ring 353. Rotational direction of adjustment ring 353 is selected by operator manipulation.

[0071] In some embodiments, delivery device 100 can be used in conjunction with an introducer device 10 as shown in FIGS. 8A-8B. Introducer devices generally include an introducer sheath 13 and a valve 11. The introducer sheath 13 is typically a resilient body. To access a bodily lumen (e.g., femoral artery) of the patient, an incision is formed in the patient's skin, and introducer sheath 13 inserted through the incision and into the desired bodily lumen. Valve 11 fluidly closes the connection with the bodily lumen external the patient. Delivery device 100 is then inserted into the bodily lumen via introducer device 10.

[0072] As generally reflected in FIG. 8A, introducer sheath 13 has an inner diameter greater than outer stability shaft 110 (as well as capsule 108), such that capsule 108 can readily be delivered through the bodily lumen, directed to other branches of the patient's vasculature 12, and then into the defective heart valve implantation site 18 (e.g., aortic heart valve). In this regard, introducer valve 11 frictionally contacts outer stability shaft 110, thereby establishing a low friction hemostasis seal around outer stability shaft 110. Outer stability shaft 110 isolates delivery sheath assembly 102 from introducer sheath 13 and valve 11. While outer stability shaft 110 is in physical contact with portions of introducer device 10, the delivery sheath assembly 102 does not directly contact introducer device 10. Further, outer stability shaft 110 overtly supports shaft 118 in traversing the tortuous vasculature, minimizing occurrences of kinks forming in shaft 118 when, for example, moving across the aortic arch 28.

[0073] Once the prosthetic heart valve 30 is positioned near the deployment site, as shown in FIG. 8A, the position of capsule 108 and retention member 120 may be finely adjusted to the desired location within the native heart valve 18 via user manipulation of adjustment mechanism 152. Because outer stability shaft 110 is not moved when adjustment mechanism 152 is manipulated, outer stability shaft 110 does not move

within the aorta as described with respect to FIGS. 1A and 1B. Thus, movement of handle 180 by adjustment mechanism 152 is directly translated to movement of capsule 108 and retention member 120, with the prosthetic heart valve disposed within capsule 108. Determination of optimal deployment location is based upon known methods such as, but not limited to sonography and radioopaque markers. As shown in FIG. 8A, capsule 108 has been roughly positioned proximally of native aortic valve 18, but is not in the desired implantation location.

[0074] Thus, a user interface for adjustment mechanism 152 of adjustment device 150 is manipulated by the user to manipulate capsule 108 to the desired deployment location. For the delivery device of the embodiment of FIG. 7, first toothed wheel 154 of adjustment mechanism 152 is rotated in direction 200, towards the distal end of adjustment device 150, such that handle 180, delivery sheath assembly 102 (including capsule 108), and inner shaft assembly 104 advance incrementally towards the desired deployment location, as shown in FIG. 8B. The movement of handle 180, delivery sheath assembly 102 (including capsule 108), and inner shaft assembly 104 is relative to adjustment device 150 and outer stability shaft 110, as described above.

[0075] To deploy prosthetic heart valve 16 from delivery device 100 at the desired deployment location, actuator mechanism 184 of handle 180 is operated proximally to retract delivery sheath assembly 102. In particular, shaft 118 and capsule 108 are moved proximally to withdraw capsule 108 from its position surrounding prosthetic heart valve 30, thereby permitting prosthetic heart valve 30 to self-deploy from delivery device 100.

[0076] Although the method is described herein using delivery device 100, it will be apparent to one of ordinary skill that methods described herein may utilize delivery device 300. For delivery device 300 of the embodiment of FIGS. 9-13E, the step of rotating first toothed wheel 154 of adjustment mechanism 152 is replaced with the step of rotating adjustment ring 353 of adjustment mechanism 352 about the longitudinal axis of the delivery device 300 such that handle 380, delivery sheath assembly 302 (including capsule 308), and inner shaft assembly 304 advance or retract incrementally towards the desired deployment location

[0077] While only some embodiments have been described herein, it should be understood that it has been presented by way of illustration and example only, and not limitation. Various changes in form and detail can be made therein without departing from the spirit and scope of the invention, and each feature of the embodiment

discussed herein, and of each reference cited herein, can be used in combination with the features of any other embodiment. All patents and publications discussed herein are incorporated by reference herein in their entirety.

CLAIMS

What is claimed is:

1. A delivery device for percutaneously delivering a stented prosthetic heart valve, the stented prosthetic heart valve being radially expandable from a radially compressed configuration to a radially expanded configuration, the delivery device comprising:

a sheath defining a lumen, wherein the sheath is configured to compressively constrain the stented prosthetic heart valve;

a handle including a housing and an actuator mechanism, wherein the actuator mechanism is coupled to a proximal portion of the sheath and is configured to selectively move the sheath relative to the housing to release the stented prosthetic heart valve;

an adjustment device coupled to the handle, wherein the adjustment device includes an adjustment lumen through which the sheath and the handle slidably extend, wherein the adjustment device includes a fine adjustment mechanism; and

an outer stability shaft coupled to the adjustment device, wherein the fine adjustment mechanism is configured to selectively move the handle and the shaft relative to the adjustment device and the outer stability shaft.

2. The delivery device of claim 1, wherein the fine adjustment mechanism includes a toothed wheel that is coupled to teeth on the handle.

3. The delivery device of claim 2, wherein the toothed wheel is oriented relative to a longitudinal axis of the adjustment device and the handle such that the toothed wheel rotates parallel to the longitudinal axis to move the handle and the shaft.

4. The delivery device of claim 2, further comprising a second toothed wheel disposed between the toothed wheel and the teeth on the handle, wherein the toothed wheel is coupled to the second toothed wheel and the second toothed wheel is coupled to the teeth on the handle.

5. The delivery device of claim 1, wherein the outer stability shaft is configured to isolate the sheath from a separate introducer valve component through which the delivery device is inserted into a patient.

6. The delivery device of claim 1, wherein the sheath comprises a distal capsule and a proximal shaft, wherein the proximal shaft is attached to an actuator mechanism of the handle, and wherein the distal capsule is configured to compressively constrain the stented prosthetic heart valve.

7. The delivery device of claim 6, wherein an outer diameter of the capsule is greater than an outer diameter of the proximal shaft, the proximal shaft being affixed to the capsule at a connection point, and further wherein in a delivery configuration, the connection point is distal of the distal end of the stability shaft by a distance in the range of 3-13 cm.

8. The delivery device of claim 6, wherein an outer diameter of the capsule is greater than an outer diameter of the proximal shaft, the capsule being affixed to the proximal shaft at a connection point, and further wherein in a deployed configuration, the connection point is distal of the distal end of the stability shaft.

9. The delivery device of claim 1, wherein the adjustment mechanism is configured to selectively move the handle and the sheath relative to the adjustment device and the outer stability shaft a distance in the range of 10-40 mm.

10. A method for restoring a defective heart valve in a patient, the method comprising the steps of:

manipulating a delivery device loaded with a radially expandable prosthetic heart valve in a radially compressed configuration, the prosthetic heart valve having a stent frame to which a valve structure is attached, the delivery device including a delivery sheath constraining the prosthetic heart valve in the radially compressed configuration, an outer stability shaft coaxially received over the delivery sheath and terminating proximal of the prosthetic heart valve with the delivery device in a delivery configuration, a handle including a housing and an actuator mechanism coupled to the delivery sheath, and an adjustment device coupled to the handle, to

guide the prosthetic heart valve through the patient's vasculature and into the defective heart valve by moving the handle, which correspondingly moves the adjustment device, delivery sheath, and stability shaft;

finely adjusting the location of the prosthetic heart valve by manipulating the fine adjustment mechanism on the adjustment device, wherein manipulating the fine adjustment mechanism causes the handle and the delivery sheath to move relative to the adjustment device and the outer stability shaft; and

withdrawing the delivery sheath from the prosthetic heart valve by actuating the actuator mechanism such that the delivery sheath slides relative to the outer stability shaft and the handle to release the prosthetic heart valve from the delivery sheath such that the prosthetic heart valve self-expands into engagement with the native heart valve.

11. The method of claim 10, wherein the step of withdrawing the delivery sheath includes the outer stability shaft isolating the delivery sheath from an introducer valve.

12. The method of claim 10, wherein the fine adjustment mechanism includes a toothed wheel that is coupled to teeth on the handle, wherein the step of finely adjusting the location of the prosthetic heart valve comprises rotating the toothed wheel to move the handle and the delivery sheath attached to the handle.

13. The method of claim 12, wherein the toothed wheel is oriented relative to the longitudinal axis of the adjustment device and the handle such that the toothed wheel rotates parallel to the longitudinal axis to move the handle and the delivery sheath.

14. The method of claim 12, further comprising a second toothed wheel disposed between the toothed wheel and the teeth on the handle, such that the step of adjusting the fine adjustment mechanism comprises rotating the toothed wheel which rotates the second toothed wheel, which moves the handle via the teeth on the handle.

15. The method of claim 10, wherein the delivery device further includes an inner shaft disposed within the delivery sheath such that the prosthetic heart valve is disposed between the inner shaft and the delivery sheath in the delivery configuration, wherein during the step of finely adjusting the location of the prosthetic heart valve the inner shaft moves with the handle and the deliver sheath relative to the adjustment device and the outer stability shaft.

16. The method of claim 15, wherein during the step of withdrawing the delivery sheath, the delivery sheath slides relative to the inner shaft.

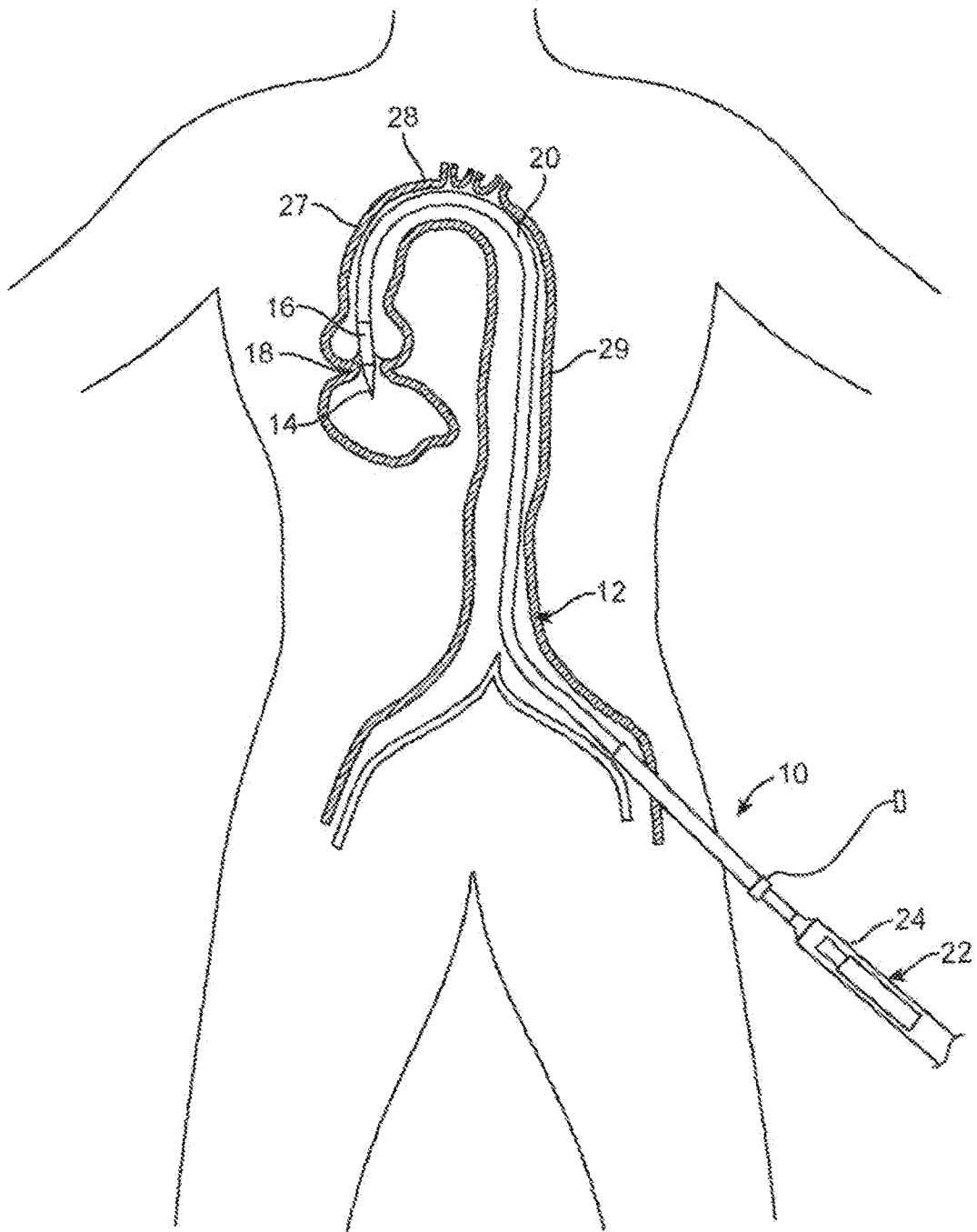

FIG. 1A
(PRIOR ART)

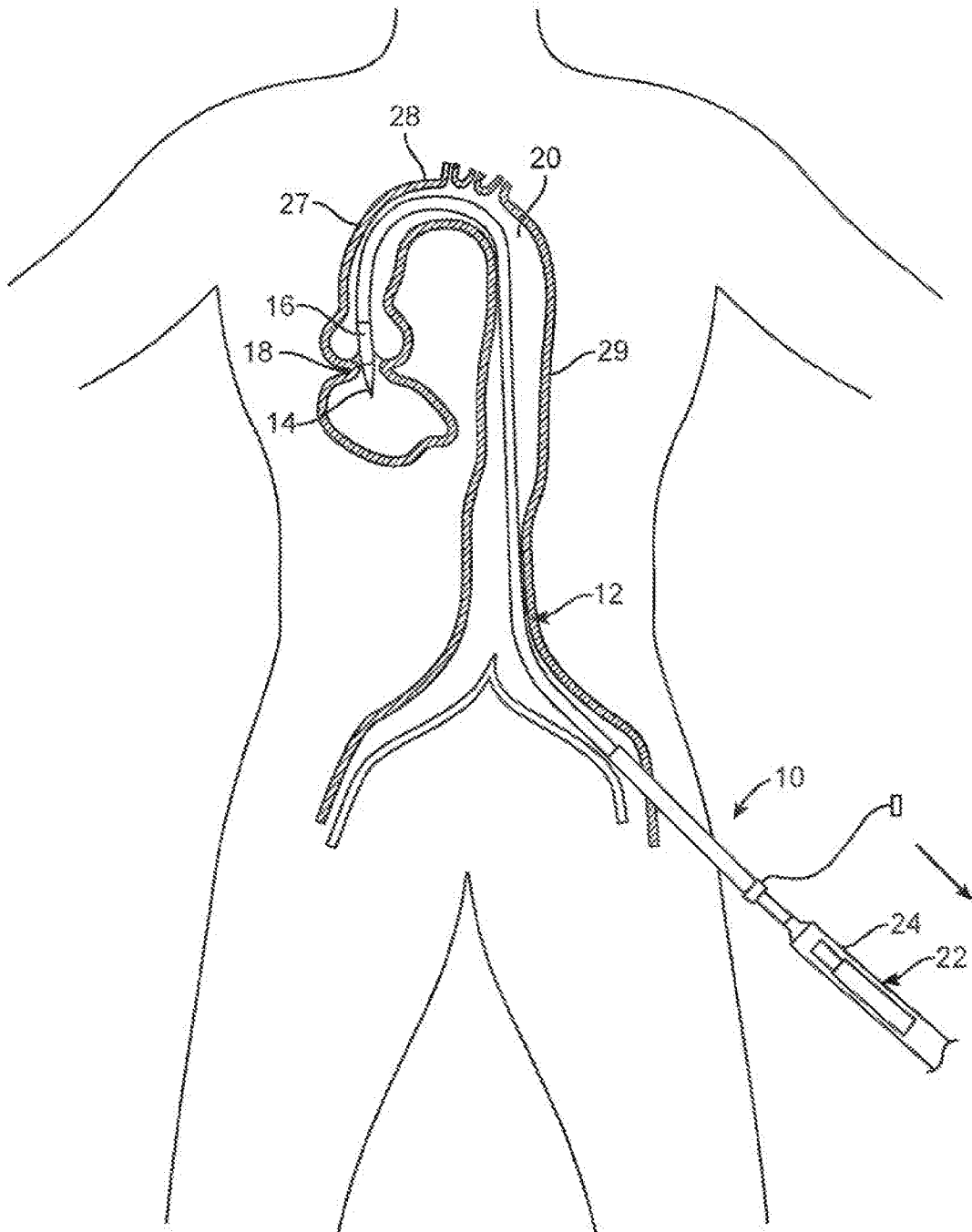

FIG. 1B
(PRIOR ART)

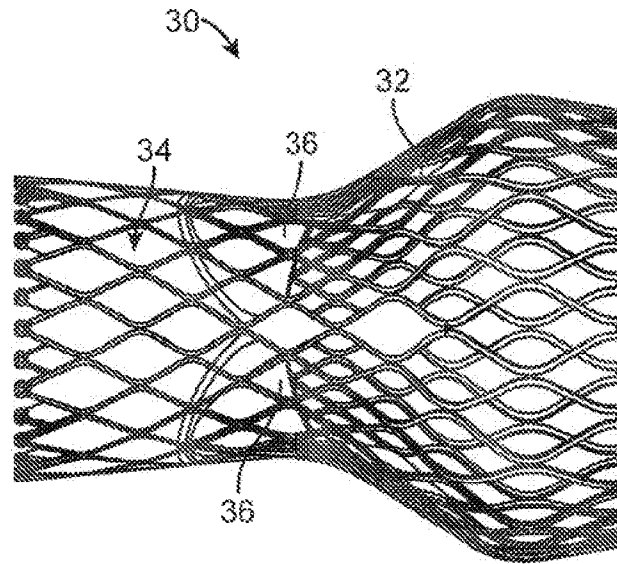

FIG. 2A
(PRIOR ART)

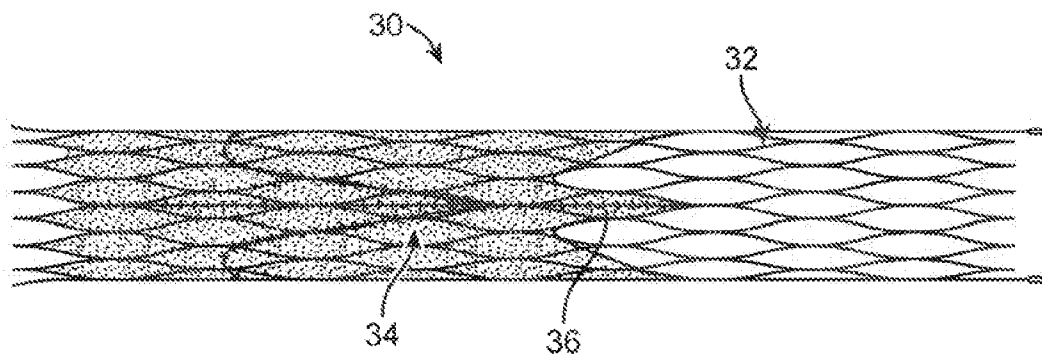

FIG. 2B
(PRIOR ART)

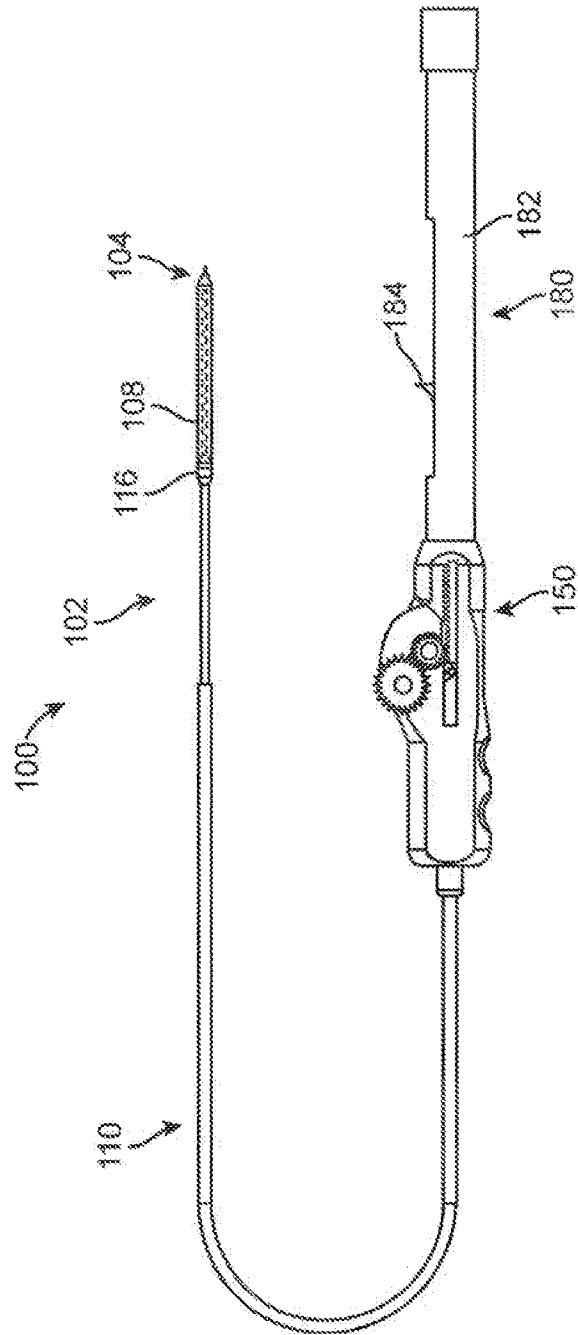

FIG. 3

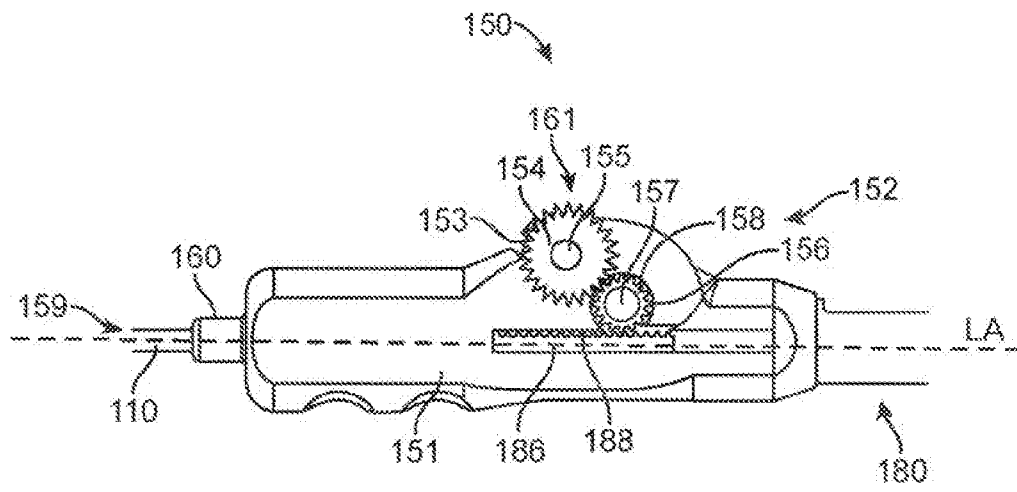

FIG. 4

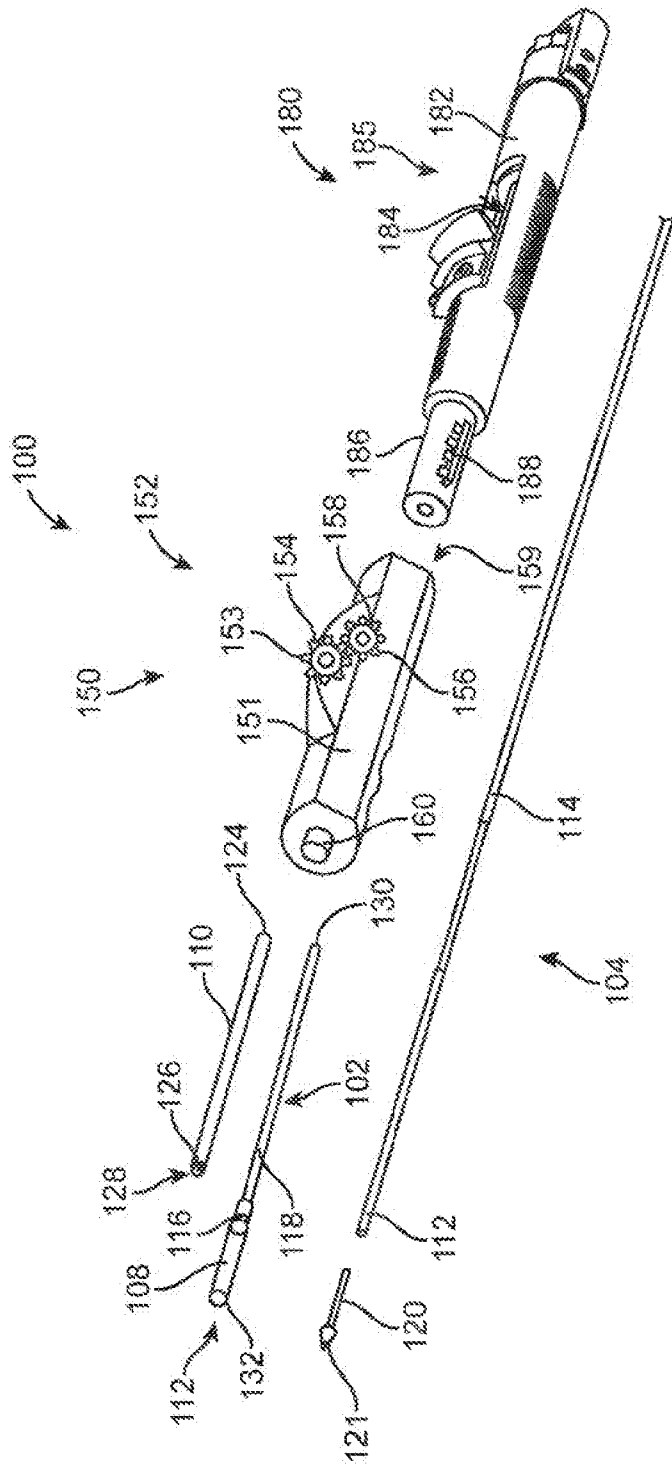

FIG. 5

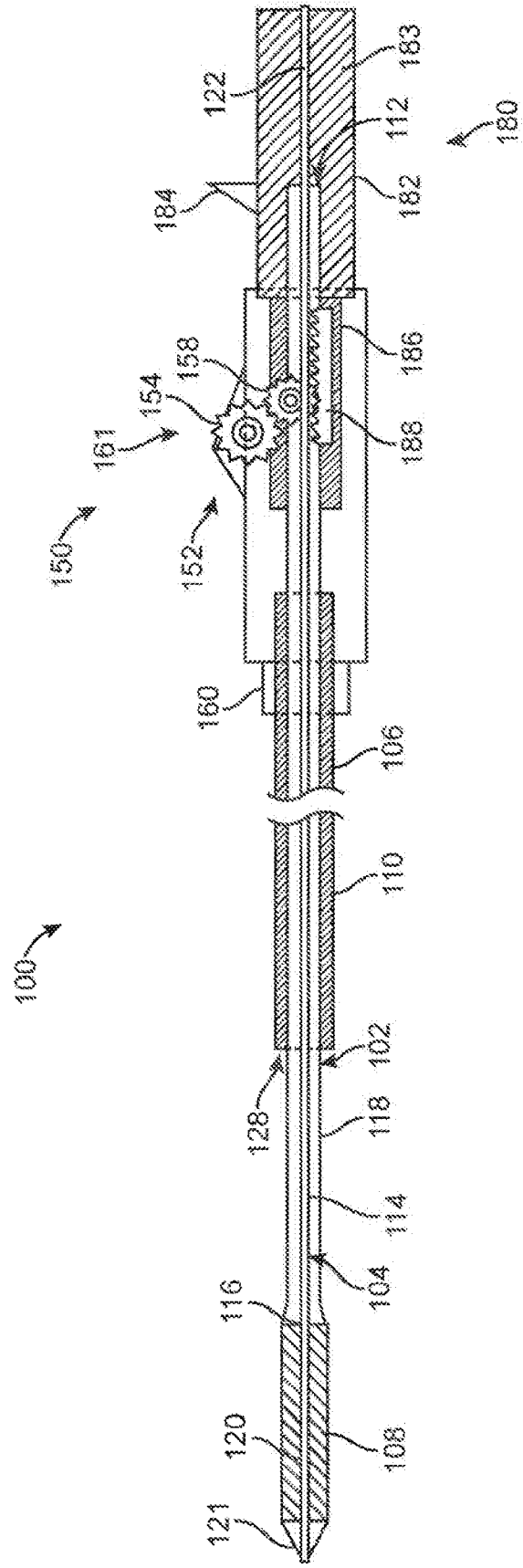

FIG. 6

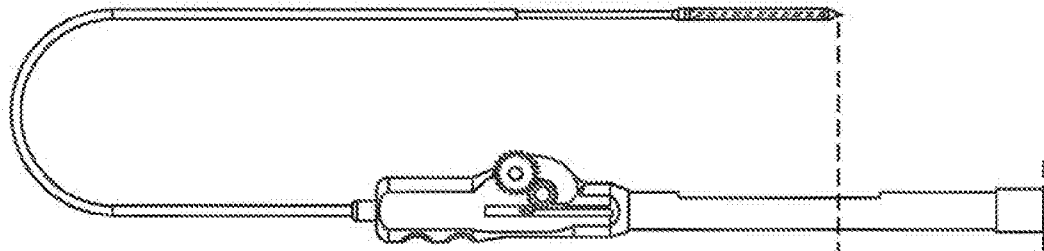

FIG. 7A

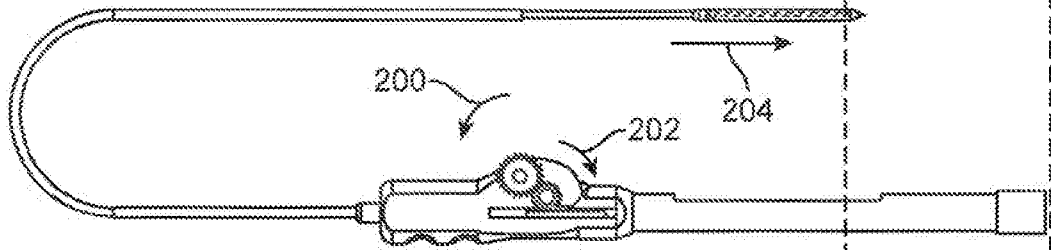

FIG. 7B

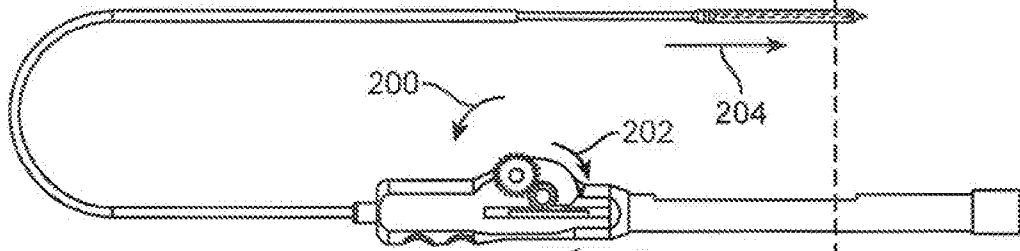

FIG. 7C

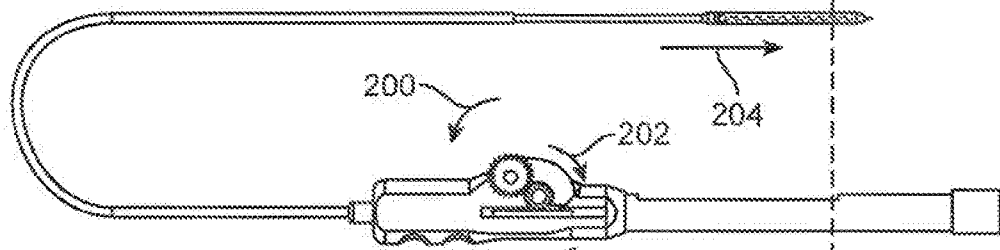

FIG. 7D

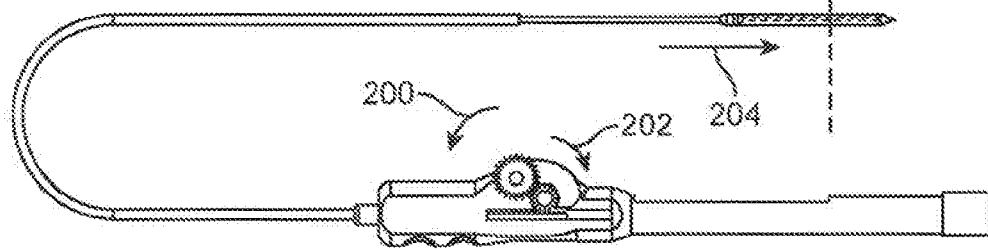

FIG. 7E

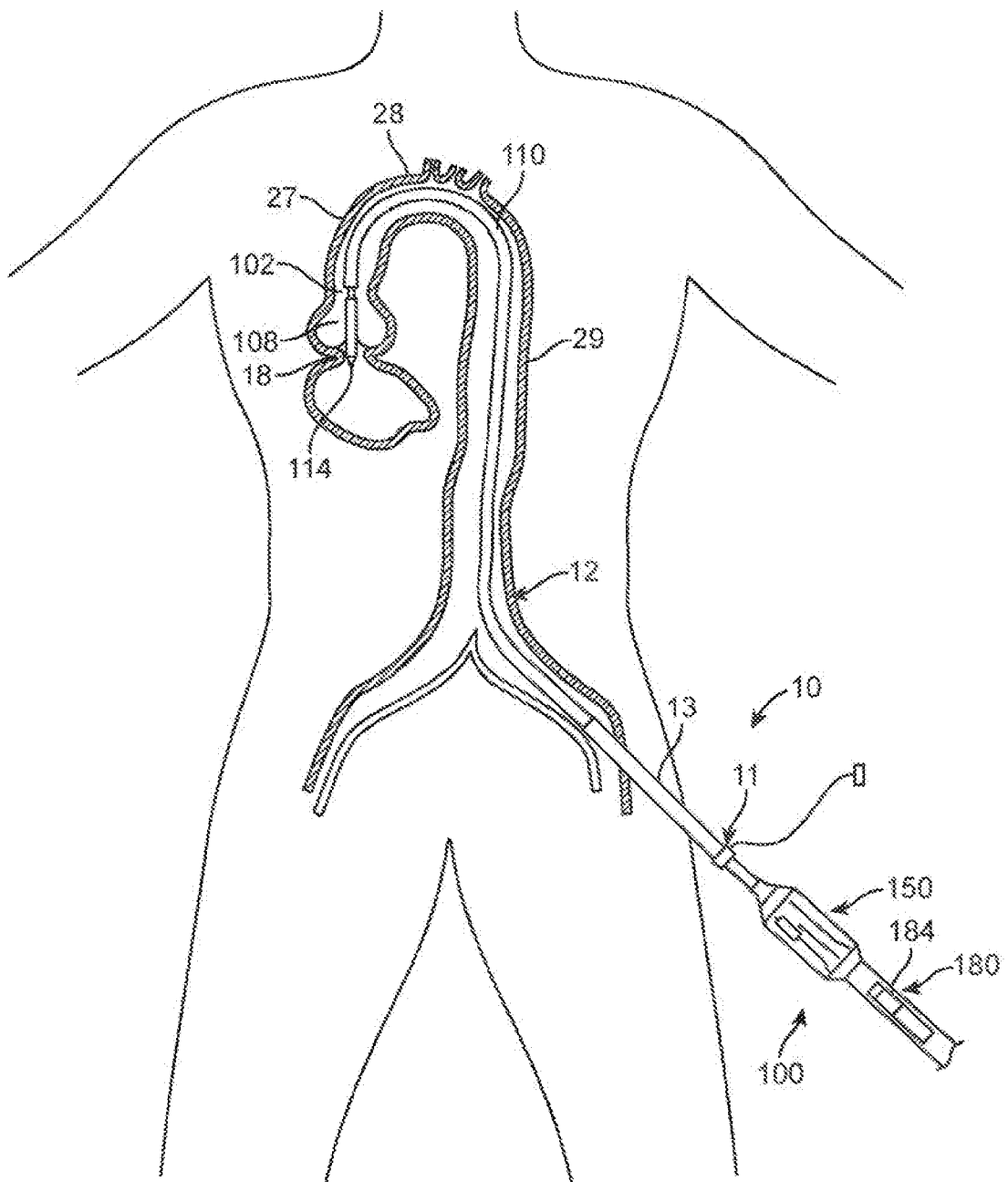

FIG. 8A

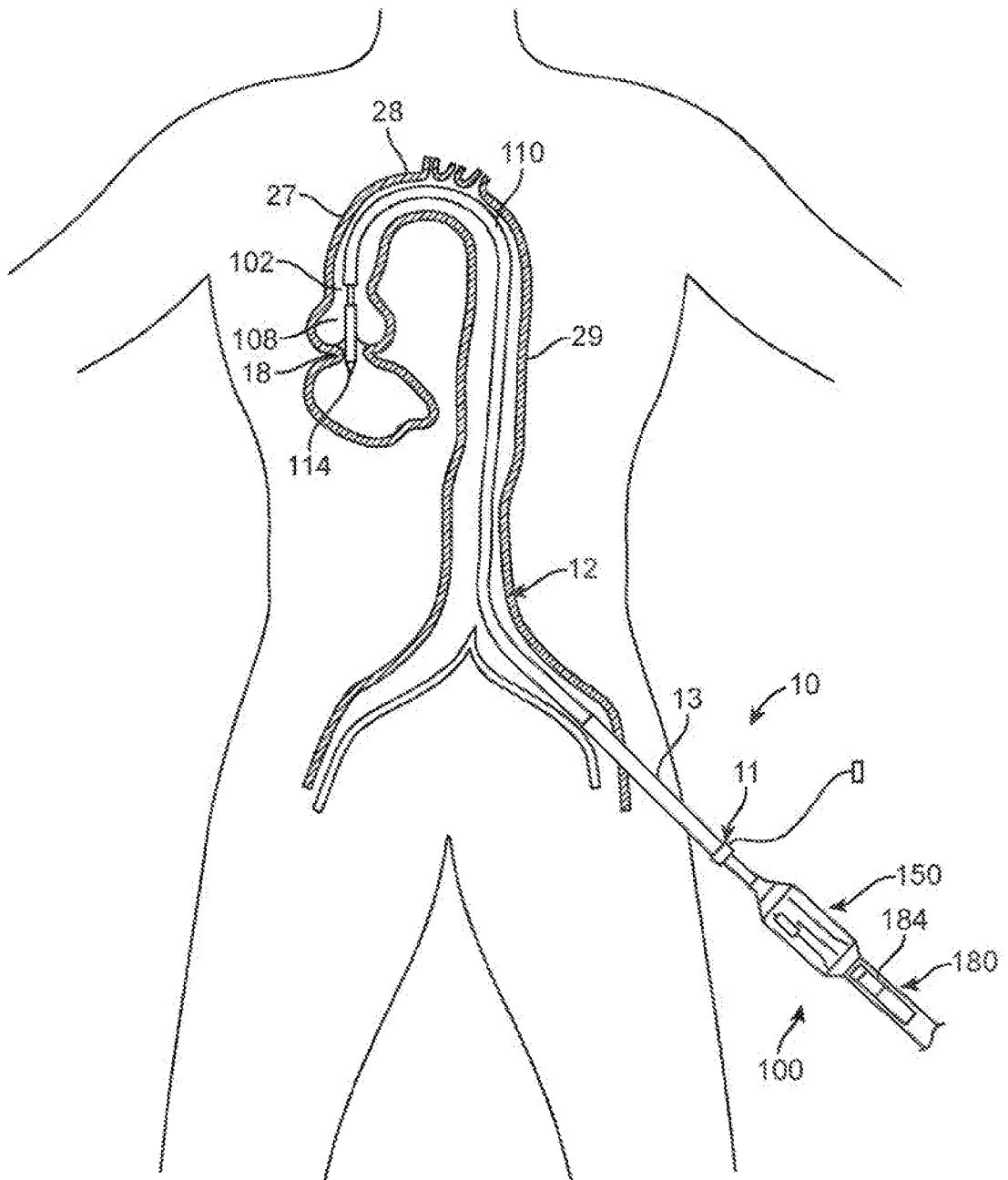

FIG. 8B

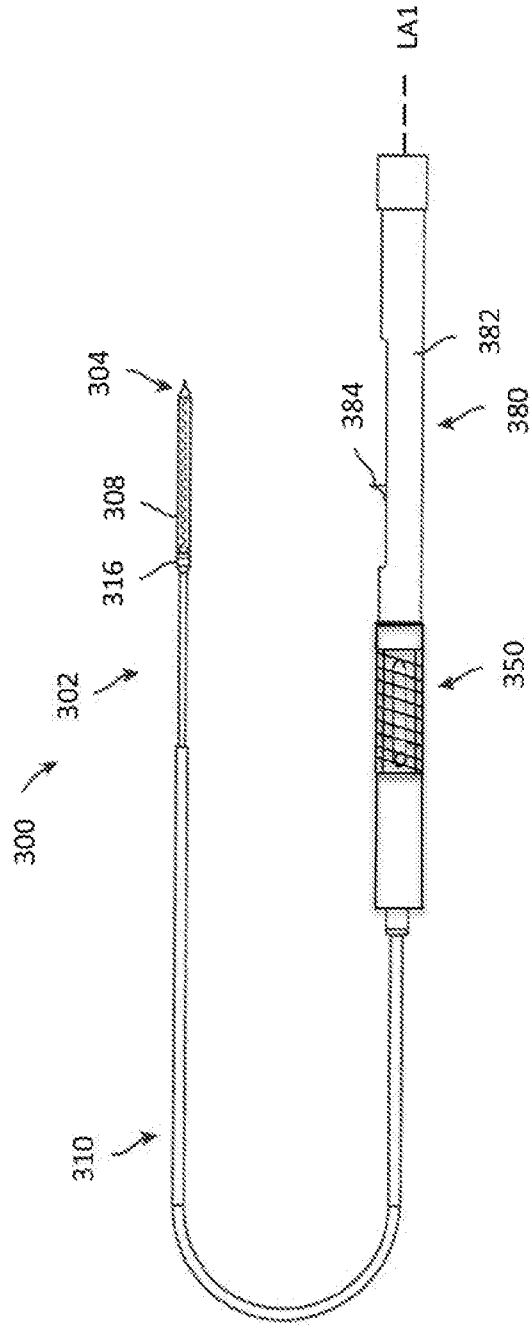

FIG. 9

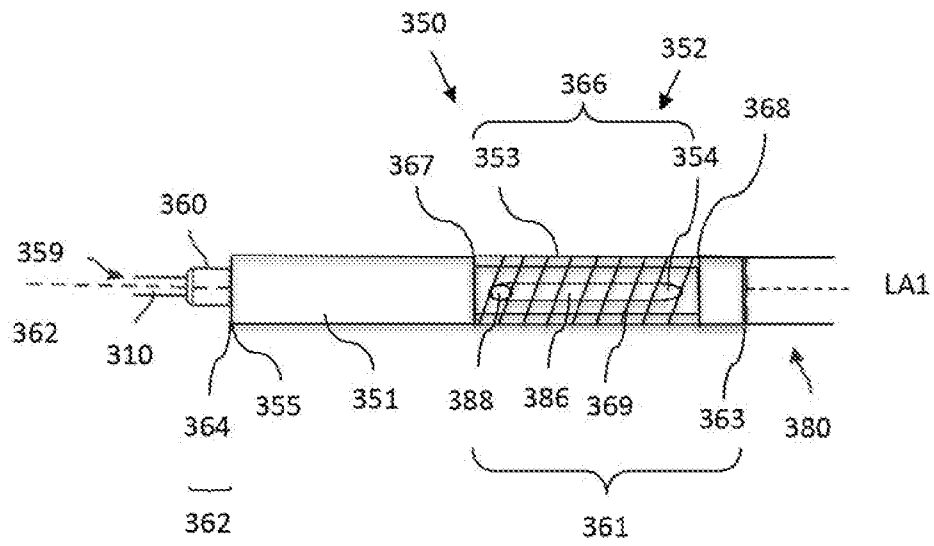

FIG. 10

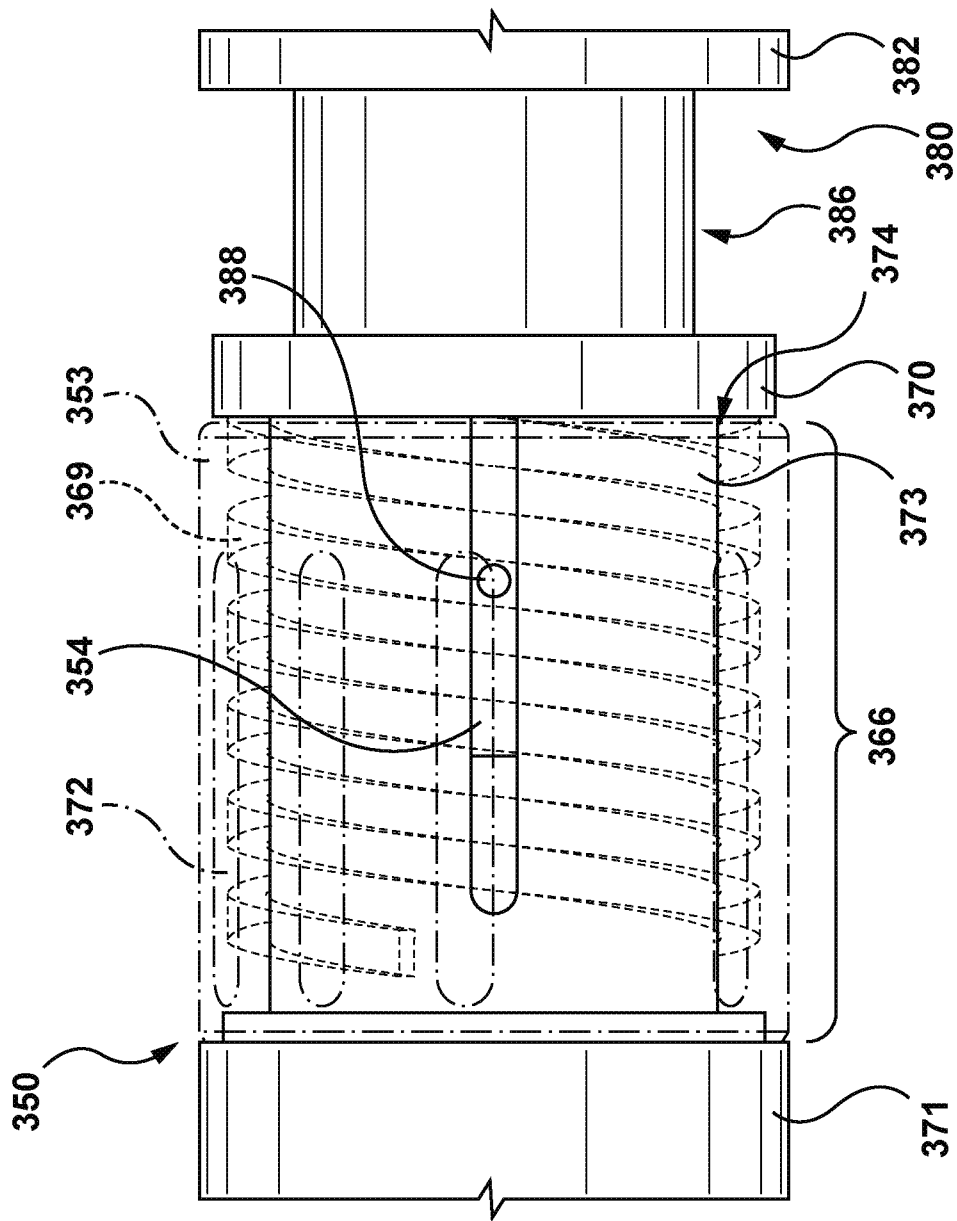

FIG. 10A

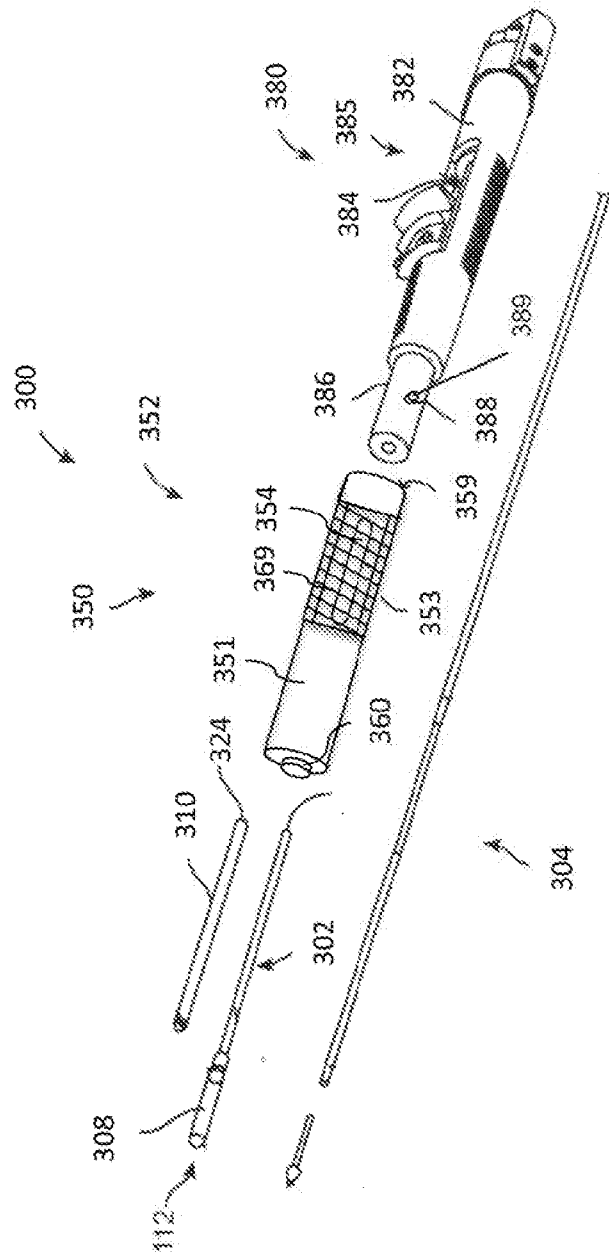

FIG. 11

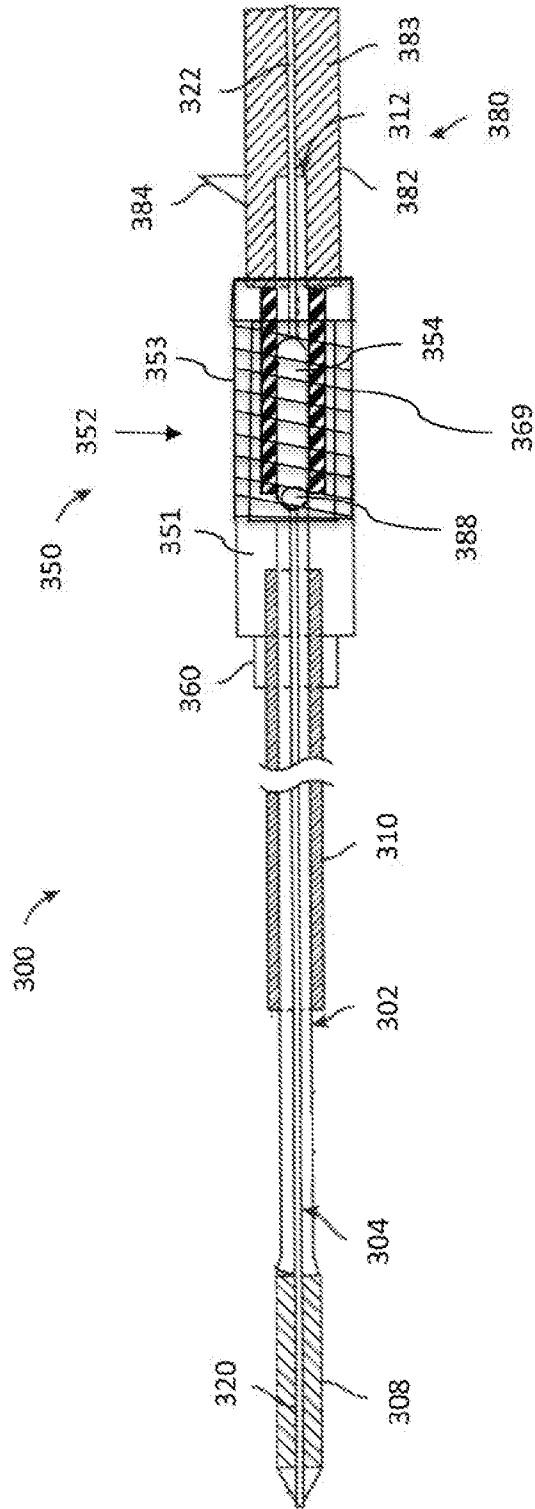

FIG. 12

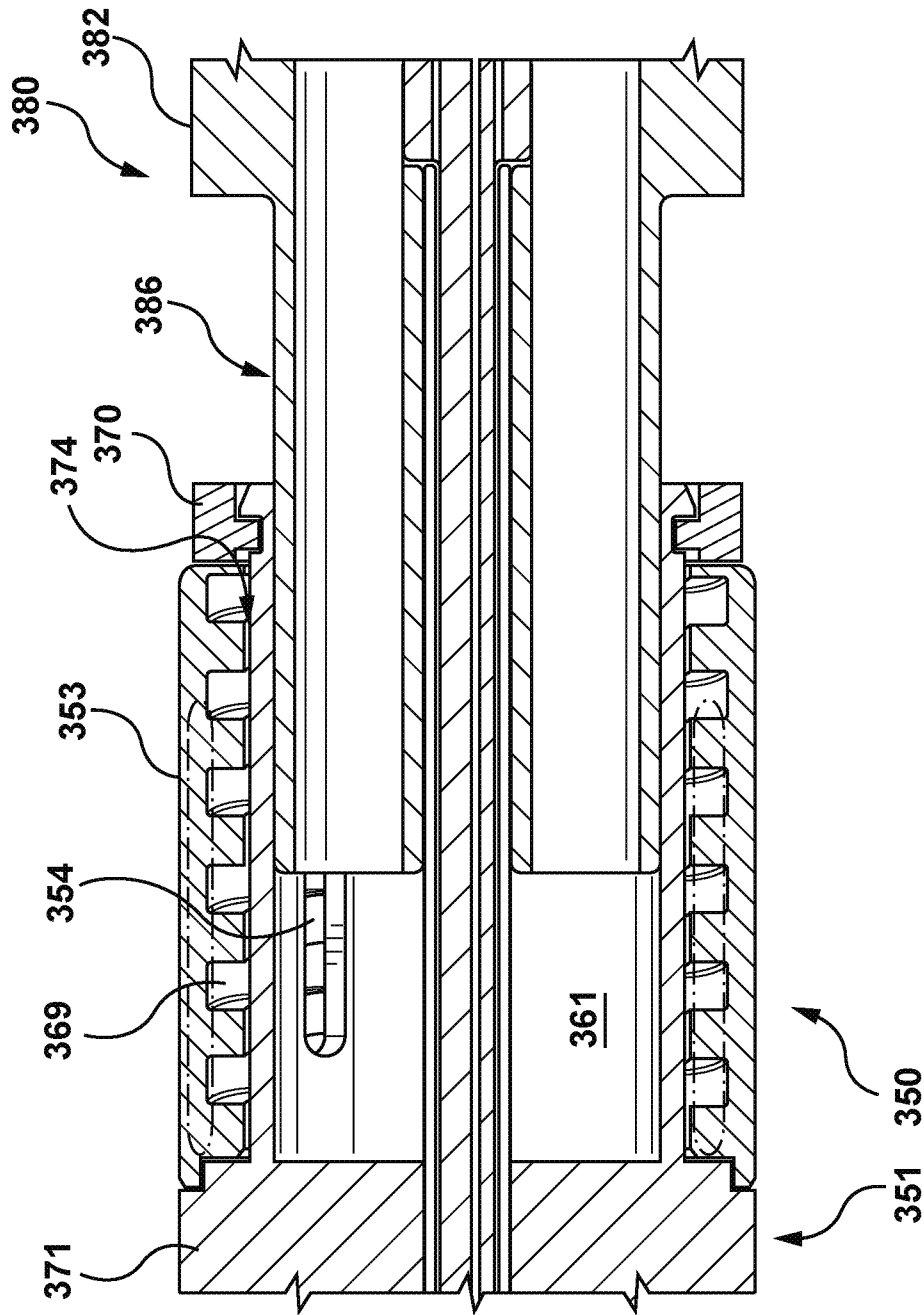

FIG. 12A

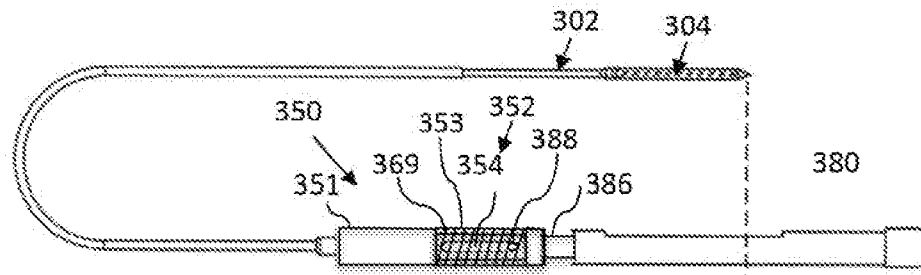

FIG. 13A

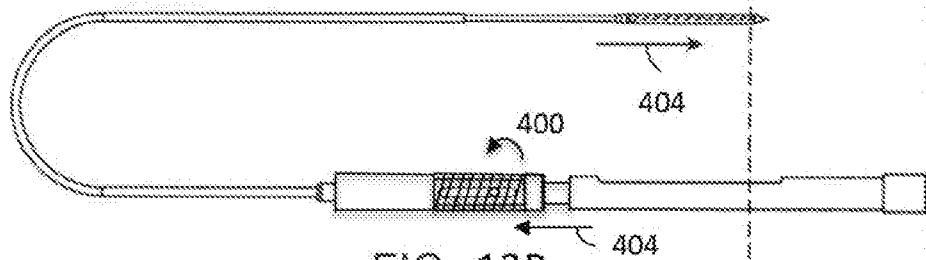

FIG. 13B

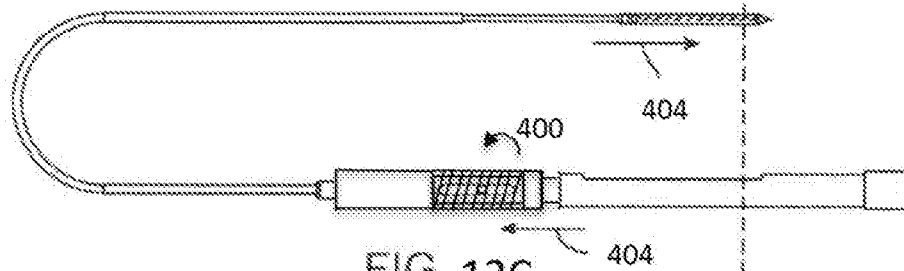

FIG. 13C

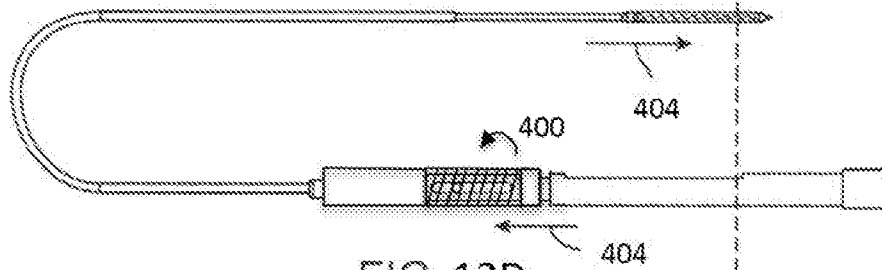

FIG. 13D

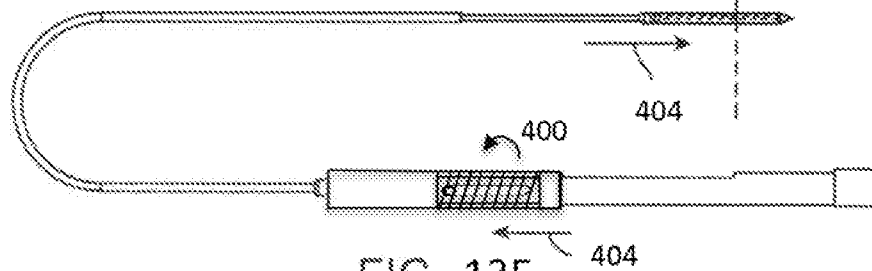

FIG. 13E

INTERNATIONAL SEARCH REPORT

International application No
PCT/US2017/021709

A. CLASSIFICATION OF SUBJECT MATTER INV. A61F2/24 ADD.		
According to International Patent Classification (IPC) or to both national classification and IPC		
B. FIELDS SEARCHED Minimum documentation searched (classification system followed by classification symbols) A61F		
Documentation searched other than minimum documentation to the extent that such documents are included in the fields searched		
Electronic data base consulted during the international search (name of data base and, where practicable, search terms used) EPO-Internal, WPI Data		
C. DOCUMENTS CONSIDERED TO BE RELEVANT		
Category*	Citation of document, with indication, where appropriate, of the relevant passages	Relevant to claim No.
X	US 2013/274856 A1 (ARBEFEUILLE SAMUEL [US] ET AL) 17 October 2013 (2013-10-17) paragraphs [0056] - [0058], [0063], [0064], [0075] - [0079]; figures 1,10,11,27A-31B -----	1-9
A	US 2014/135909 A1 (CARR DAMIAN [IE] ET AL) 15 May 2014 (2014-05-15) paragraphs [0027] - [0034]; figures 1A-4 -----	1-9
X,P	WO 2016/149083 A1 (MEDTRONIC VASCULAR INC [US]) 22 September 2016 (2016-09-22) claims 1-9 -----	1-9
<input type="checkbox"/> Further documents are listed in the continuation of Box C. <input checked="" type="checkbox"/> See patent family annex.		
* Special categories of cited documents :		
"A" document defining the general state of the art which is not considered to be of particular relevance "E" earlier application or patent but published on or after the international filing date "L" document which may throw doubts on priority claim(s) or which is cited to establish the publication date of another citation or other special reason (as specified) "O" document referring to an oral disclosure, use, exhibition or other means "P" document published prior to the international filing date but later than the priority date claimed		"T" later document published after the international filing date or priority date and not in conflict with the application but cited to understand the principle or theory underlying the invention "X" document of particular relevance; the claimed invention cannot be considered novel or cannot be considered to involve an inventive step when the document is taken alone "Y" document of particular relevance; the claimed invention cannot be considered to involve an inventive step when the document is combined with one or more other such documents, such combination being obvious to a person skilled in the art "&" document member of the same patent family
Date of the actual completion of the international search 16 May 2017		Date of mailing of the international search report 24/05/2017
Name and mailing address of the ISA/ European Patent Office, P.B. 5818 Patentlaan 2 NL - 2280 HV Rijswijk Tel. (+31-70) 340-2040, Fax: (+31-70) 340-3016		Authorized officer Chevalot, Nicolas

INTERNATIONAL SEARCH REPORT

International application No.
PCT/US2017/021709

Box No. II Observations where certain claims were found unsearchable (Continuation of item 2 of first sheet)

This international search report has not been established in respect of certain claims under Article 17(2)(a) for the following reasons:

1. Claims Nos.: 10-16
because they relate to subject matter not required to be searched by this Authority, namely:
Rule 39.1(iv) PCT - Method for treatment of the human body by surgery.
2. Claims Nos.:
because they relate to parts of the international application that do not comply with the prescribed requirements to such an extent that no meaningful international search can be carried out, specifically:
3. Claims Nos.:
because they are dependent claims and are not drafted in accordance with the second and third sentences of Rule 6.4(a).

Box No. III Observations where unity of invention is lacking (Continuation of item 3 of first sheet)

This International Searching Authority found multiple inventions in this international application, as follows:

1. As all required additional search fees were timely paid by the applicant, this international search report covers all searchable claims.
2. As all searchable claims could be searched without effort justifying an additional fees, this Authority did not invite payment of additional fees.
3. As only some of the required additional search fees were timely paid by the applicant, this international search report covers only those claims for which fees were paid, specifically claims Nos.:
4. No required additional search fees were timely paid by the applicant. Consequently, this international search report is restricted to the invention first mentioned in the claims; it is covered by claims Nos.:

Remark on Protest

- The additional search fees were accompanied by the applicant's protest and, where applicable, the payment of a protest fee.
- The additional search fees were accompanied by the applicant's protest but the applicable protest fee was not paid within the time limit specified in the invitation.
- No protest accompanied the payment of additional search fees.

INTERNATIONAL SEARCH REPORT

Information on patent family members

International application No

PCT/US2017/021709

Patent document cited in search report	Publication date	Patent family member(s)	Publication date
US 2013274856 A1	17-10-2013	CN 104363862 A	18-02-2015
		EP 2846743 A1	18-03-2015
		EP 3141223 A1	15-03-2017
		JP 2015512746 A	30-04-2015
		US 2013274856 A1	17-10-2013
		US 2015173922 A1	25-06-2015
		US 2017100271 A1	13-04-2017
		WO 2013154749 A1	17-10-2013

US 2014135909 A1	15-05-2014	EP 2919712 A1	23-09-2015
		US 2014135909 A1	15-05-2014
		WO 2014078135 A1	22-05-2014

WO 2016149083 A1	22-09-2016	US 2016262883 A1	15-09-2016
		WO 2016148910 A1	22-09-2016
		WO 2016149083 A1	22-09-2016
