

W. H. COOKE.  
RAILROAD-SWITCH.

No. 184,760.

Patented Nov. 28, 1876.

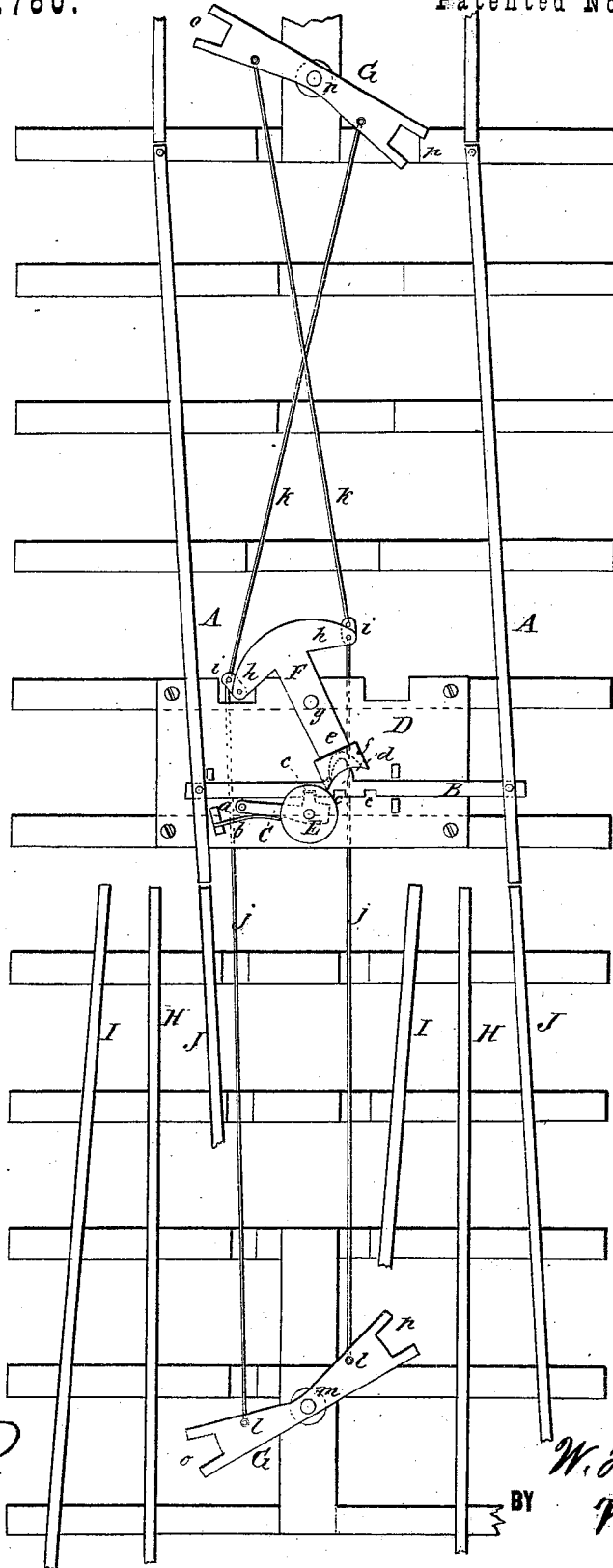

WITNESSES:  
*Chas. Nida*  
*A. F. Roberts*

INVENTOR:  
*W. H. Cooke*  
BY *Munnell & Co.*  
ATTORNEYS.

# UNITED STATES PATENT OFFICE.

WILLIAM H. COOKE, OF WILTON, CONNECTICUT.

## IMPROVEMENT IN RAILROAD-SWITCHES.

Specification forming part of Letters Patent No. 184,760, dated November 28, 1876; application filed November 4, 1876.

To all whom it may concern:

Be it known that I, WILLIAM H. COOKE, of Wilton, in the county of Fairfield and State of Connecticut, have invented a new and Improved Automatic Self-Locking Switch, of which the following is a specification:

My invention relates to the class of switches that are operated by the passing locomotive; and it consists in the combination of a notched bar that is connected with the movable switch-rails, and a locking-lever that is capable of engaging with the notches of the said bar, and a T-lever, by which the said locking-lever is disengaged, and the notched bar and rails are moved; and also in levers placed each side of and remote from the notched bar, and connected with the T-lever by means of rods. The said levers are capable of being moved by the locomotive.

Referring to the drawing, A A are the movable switch-rails, that are connected near their free ends by a bar, B, that is pivoted to the said rails, and is notched at *c c c* to receive a locking-lever or tumbler, C, which is pivoted to the bed-plate D of the switching apparatus at *a*, and is pressed into the notches *c* by a spring, *b*. E is a wheel pivoted on the locking-lever C. A tooth, *d*, is formed on the side of the bar B, opposite the notches *c*, and F is a T-lever pivoted at *g*, the forked end of whose center arm *e* engages the tooth *d*, and a plate, *f*, having a concave edge, is attached to the end of the arm *e*, in position to engage the wheel E. The fork in the end of the arm *e* is made somewhat larger than the tooth *d*, for the purpose of allowing the lever F to move sufficiently to disengage the locking-lever before coming in contact with the tooth *d*. The arms *h h* of the lever F are provided with links *i*, to which are jointed the rods *j j* and *k k*. The rods *j* are connected at *l l* with a lever, G, having two similar arms, each of which is notched at its end to receive a finger or tappet that projects downward from the locomotive, for the purpose of moving the said lever. This lever is pivoted centrally between the rails, at *m*, at a suitable distance from the switch-rails. G' is a lever similar to the one just described, that is piv-

oted at *n* between the track-rails, and connected by the rods *k k*, which are crossed to the lever F.

By this arrangement the levers G G' are made to move in opposite directions. The notches *c c c*, in the bar B, are placed so that the locking-lever C may lock the switch-rails A A, when opposite either the main track-rails H or the branches I or J. Fingers or tappets are attached to the locomotive, which are capable of being thrown down so as to engage with either end of the levers G G'.

When the train is advancing on the main track toward the switch, and the switch is set to the branch J, and it is desired to continue on the main track, a tappet is thrown down that engages with the end *o* of either of the levers G G', and by this means moves the lever F, which first throws the locking-lever C out of the notch *c* in the bar B, by the engagement of the plate *f* with the wheel E, and then it moves the bar B by engaging the tooth *d* until the locking-lever drops into the center notch in the bar, by which means the switch-rails are rigidly held in their position as a portion of the main track.

The operation of switching from the main track to the other branch, or from the branches to the main track, is similar to that just described. The apparatus is worked by an engine approaching from either direction.

By means of the peculiar arrangement of the T-lever, the locking-lever, and the notched bar, the switch-rails may be placed in either of three positions by the fingers or tappets projecting from the engine, and when so placed are automatically and securely locked.

Having thus described my invention, I claim as new and desire to secure by Letters Patent—

The bar B, having the notches *c* and tooth *d*, in combination with the locking-lever C, wheel E, lever F, having the plate *f*, and the levers G G', and their connecting-rods *j* and *k*, substantially as shown and described.

WILLIAM H. COOKE.

Witnesses:

SARAH A. GREGORY,  
CHARLES R. MOREHOUSE.