



(12) **United States Design Patent**  
**Wiegel et al.**

(10) **Patent No.:** **US D722,155 S**  
(45) **Date of Patent:** **\*\* Feb. 3, 2015**

(54) **CANNULA CONNECTOR**

(75) Inventors: **Heinz Wiegel**, Alheim (DE); **Iris Blum**,  
Fuldabrueck (DE); **Martin Sippel**,  
Melsungen (DE); **Helmut Freigang**,  
Koerle (DE); **Benjamin Olson**,  
Fuldabrueck (DE); **Thilo Hogrebe**,  
Hamburg (DE); **Fred Held**, Hamburg  
(DE)

(73) Assignee: **B. Braun Melsungen AG**, Melsungen  
(DE)

(\*\*) Term: **14 Years**

(21) Appl. No.: **29/426,664**

(22) Filed: **Jul. 9, 2012**

(30) **Foreign Application Priority Data**

Jan. 9, 2012 (EM) ..... 00197282900010003

(51) **LOC (10) Cl.** ..... **24-02**

(52) **U.S. Cl.**  
USPC ..... **D24/112**

(58) **Field of Classification Search**  
CPC ..... A61M 39/10; A61M 39/1011; A61M  
2039/1077; A61M 2039/1038  
USPC ..... D24/107, 108, 110, 110.6; 604/19, 48,  
604/93.1, 246, 533, 537, 538, 905

See application file for complete search history.

(56) **References Cited**

U.S. PATENT DOCUMENTS

|                   |         |                       |           |
|-------------------|---------|-----------------------|-----------|
| D644,731 S *      | 9/2011  | Fangrow, Jr. ....     | D24/129   |
| 2003/0209681 A1 * | 11/2003 | Leinsing et al. ....  | 251/149.1 |
| 2005/0165365 A1 * | 7/2005  | Newton et al. ....    | 604/246   |
| 2007/0043334 A1 * | 2/2007  | Guala ..... ..        | 604/533   |
| 2007/0224865 A1 * | 9/2007  | Fangrow ..... ..      | 439/205   |
| 2008/0249508 A1 * | 10/2008 | Lopez et al. ....     | 604/533   |
| 2010/0036330 A1 * | 2/2010  | Plishka et al. ....   | 604/256   |
| 2011/0137294 A1 * | 6/2011  | Calimeri et al. ....  | 604/533   |
| 2013/0150795 A1 * | 6/2013  | Snow ..... ..         | 604/174   |
| 2013/0338608 A1 * | 12/2013 | Moorehead et al. .... | 604/246   |

\* cited by examiner

*Primary Examiner* — Deanna L Pratt

*Assistant Examiner* — Ieisha Price

(74) *Attorney, Agent, or Firm* — Ohlandt, Greeley, Ruggiero  
& Perle, LLP

(57) **CLAIM**

The ornamental design for the cannula connector, as shown  
and described.

**DESCRIPTION**

FIG. 1 is a bottom, rear, left-side perspective view of a can-  
nula connector according to the present invention;  
FIG. 2 is a top plan view of the cannula connector of FIG. 1;  
FIG. 3 is a bottom view of the cannula connector of FIG. 1;  
FIG. 4 is a right side view of the cannula connector of FIG. 1;  
FIG. 5 is a left side view of the cannula connector of FIG. 1;  
FIG. 6 is a front plan view of the cannula connector of FIG. 1;  
and,  
FIG. 7 is a rear plan view of the cannula connector of FIG. 1.  
The broken lines in the drawings illustrating portions of the  
cannula connector that form no part of the claimed design.

**1 Claim, 6 Drawing Sheets**

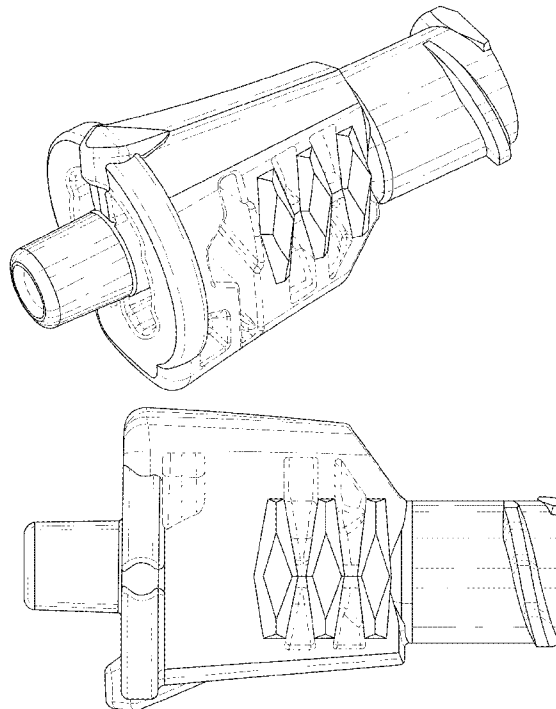

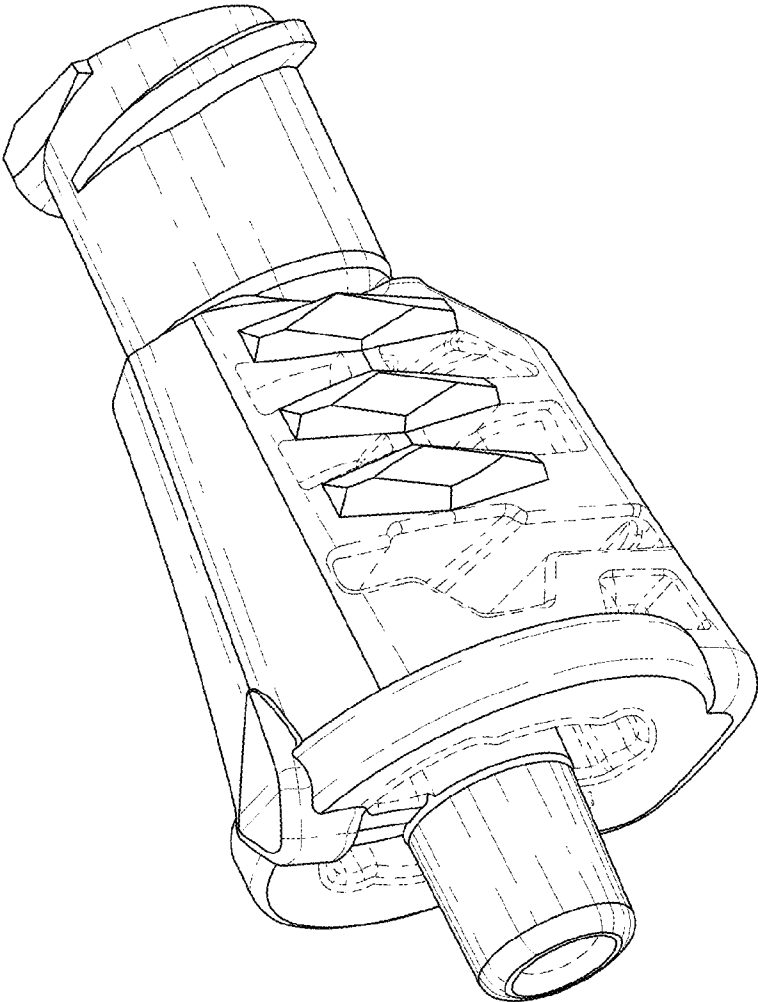

FIG. 1

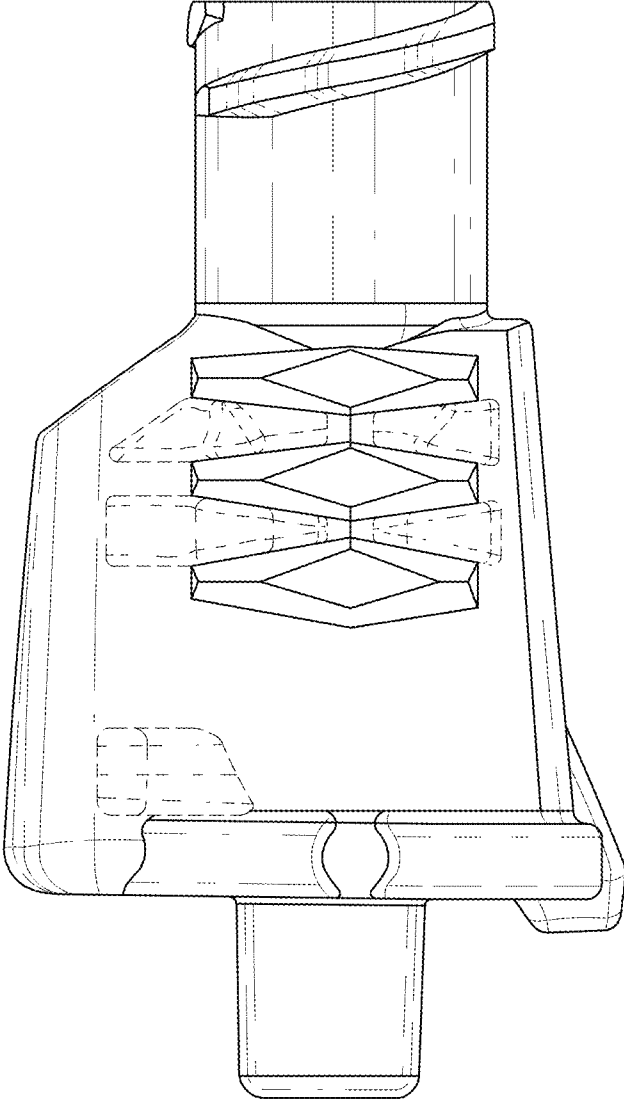

FIG. 2

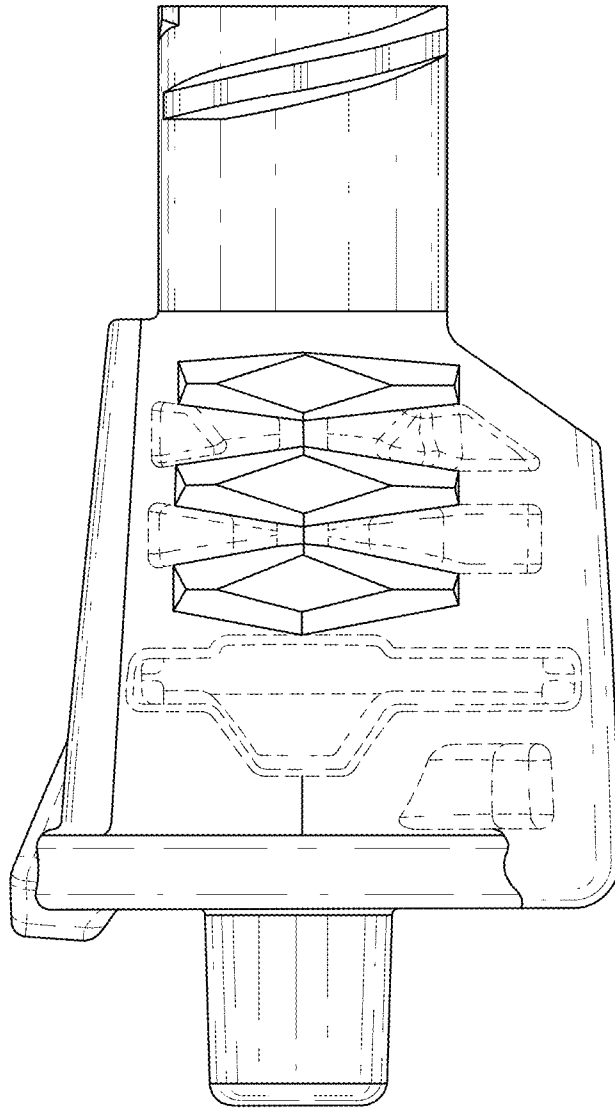

FIG. 3

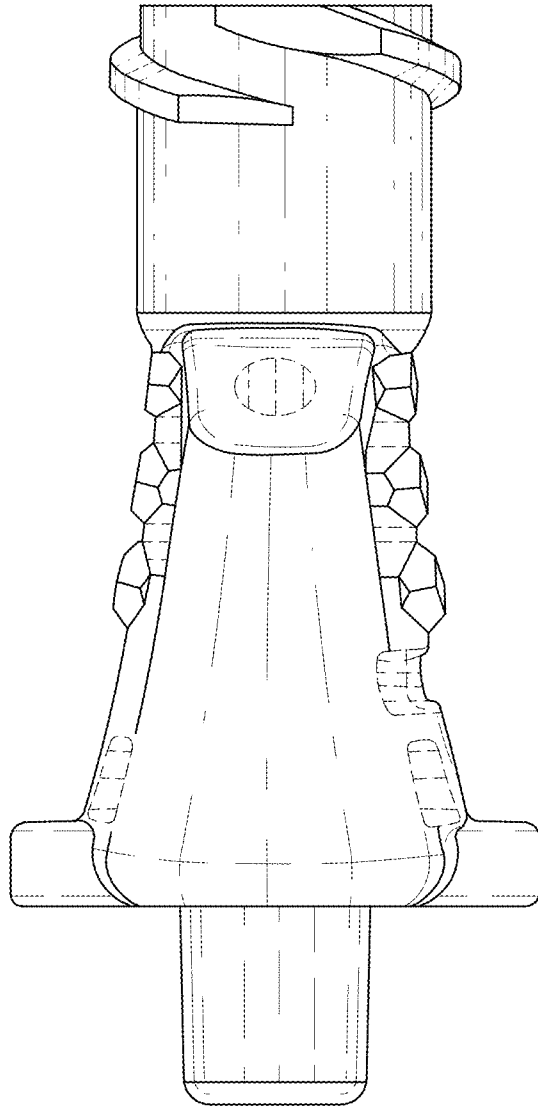

FIG. 4

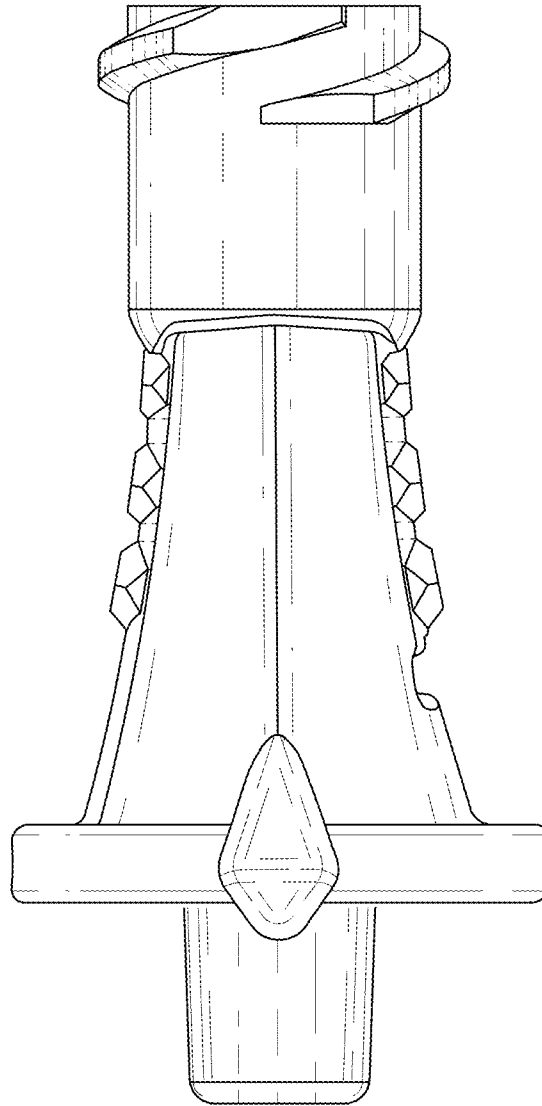

FIG. 5

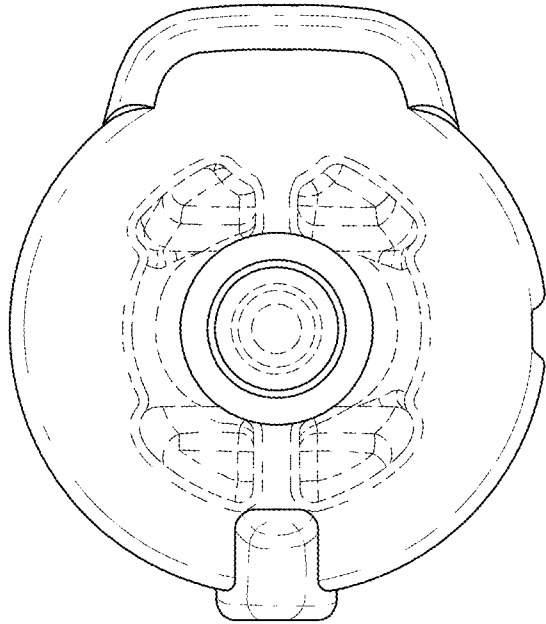

FIG. 7

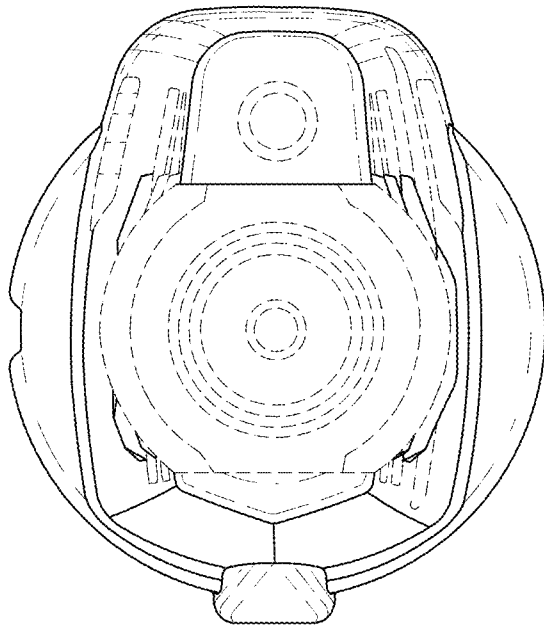

FIG. 6