

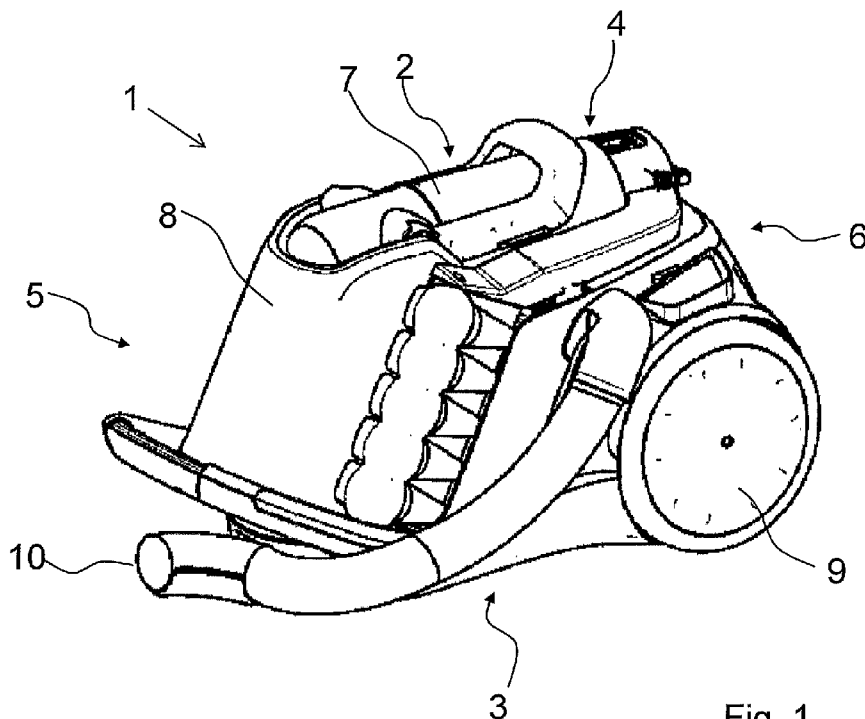

- (51) International Patent Classification:
A47L 9/10 (2006.01) A47L 9/00 (2006.01)
- (21) International Application Number:
PCT/EP2012/053025
- (22) International Filing Date:
22 February 2012 (22.02.2012)
- (25) Filing Language: English
- (26) Publication Language: English
- (30) Priority Data:
PCT/EP2011/000844
22 February 2011 (22.02.2011) EP
- (71) Applicant (for all designated States except US): **AK-TIEBOLAGET ELECTROLUX** [SE/SE]; S:t Göransgatan 143, S-105 45 Stockholm (SE).
- (72) Inventors; and
(75) Inventors/Applicants (for US only): **MIEFALK, Håkan** [SE/SE]; AB Electrolux, S:t Göransgatan 143, S-105 45 Stockholm (SE). **SVANTESSON, Esbjörn** [SE/SE]; AB Electrolux, S:t Göransgatan 143, S-105 45 Stockholm (SE).
- (74) Agent: **WRETBLAD, Eva**; c/o AB Electrolux, S:t Göransgatan 143, S-105 45 Stockholm (SE).
- (81) Designated States (unless otherwise indicated, for every kind of national protection available): AE, AG, AL, AM, AO, AT, AU, AZ, BA, BB, BG, BH, BR, BW, BY, BZ, CA, CH, CL, CN, CO, CR, CU, CZ, DE, DK, DM, DO, DZ, EC, EE, EG, ES, FI, GB, GD, GE, GH, GM, GT, HN, HR, HU, ID, IL, IN, IS, JP, KE, KG, KM, KN, KP, KR, KZ, LA, LC, LK, LR, LS, LT, LU, LY, MA, MD, ME, MG, MK, MN, MW, MX, MY, MZ, NA, NG, NI, NO, NZ, OM, PE, PG, PH, PL, PT, QA, RO, RS, RU, RW, SC, SD, SE, SG, SK, SL, SM, ST, SV, SY, TH, TJ, TM, TN, TR, TT, TZ, UA, UG, US, UZ, VC, VN, ZA, ZM, ZW.
- (84) Designated States (unless otherwise indicated, for every kind of regional protection available): ARIPO (BW, GH, GM, KE, LR, LS, MW, MZ, NA, RW, SD, SL, SZ, TZ, UG, ZM, ZW), Eurasian (AM, AZ, BY, KG, KZ, MD, RU, TJ, TM), European (AL, AT, BE, BG, CH, CY, CZ, DE, DK, EE, ES, FI, FR, GB, GR, HR, HU, IE, IS, IT, LT, LU, LV, MC, MK, MT, NL, NO, PL, PT, RO, RS, SE, SI, SK, SM, TR), OAPI (BF, BJ, CF, CG, CI, CM, GA, GN, GQ, GW, ML, MR, NE, SN, TD, TG).

[Continued on next page]

(54) Title: VACUUM CLEANER



(57) Abstract: The present invention is directed to a vacuum cleaner (1) comprising a horizontal type cleaner body (2) with a bottom (3), top (4), front (5) and back side (6), a suction blower unit accommodated in the cleaner body (2) and at least one primary stage cyclone dust separator (7) having an air inlet opening fluidly coupled to the suction blower unit, wherein in bottom to top direction the primary stage cyclone dust separator (7) is positioned over the suction blower unit, and wherein the air inlet opening and a dust outlet opening of the primary stage cyclone dust separator (7) are located towards the back side (6) and front side (5) respectively.

Fig. 1

Published:

— *with international search report (Art. 21(3))*

Vacuum Cleaner

The present invention is directed to a vacuum cleaner. In more detail, the invention is directed to a cyclone type vacuum cleaner.
5

Cyclone type vacuum cleaners are widely known because of their benefit in bagless dust collection. Bagless or cyclone type vacuum cleaners or respective cyclone dust separating units are known for example from documents EP 1 042 981 A1, EP 1774887 A1, EP 1 688 078 A2, EP 1 952 745 A2 and WO 2011/058365.
10

Cyclone type vacuum cleaners, in particular mentioned in the state of technology documents listed before, are still comparatively large in size and provide comparatively complicated air guiding and dust collecting devices and units.
15

Therefore, it is one of the objects of the present invention to provide a cyclone type vacuum cleaner having a comparatively compact design. Further, the vacuum cleaner shall have enhanced usability and operability, in particular with respect to dust separation and dust collecting chambers.
20

These and further objects, are solved by the features of claim 1. Embodiments and variants result from the dependent claims.
25

According to claim 1, a vacuum cleaner is provided which comprises a horizontal type cleaner body having a bottom, top, front and back side. The term "horizontal type cleaner body" in particular shall refer to the orientation of the cleaner body in normal or intended use. Such a horizontal type cleaner body may comprise, as already implemented with known devices, wheels attached thereto and provided for easily moving the vacuum cleaner over the floor underneath during vacuum-cleaning.
30

35

A horizontal type vacuum cleaner in the meaning of the present application is for example shown in EP 1 774 887 A1. Aside from the horizontal type vacuum cleaners there also exist vertical type constructions generally comprising a handle to which the cleaner body is mounted to and by which the cleaner body is moved in concert with vacuum-cleaning operations. One example of such a vertical type vacuum cleaner is shown in WO 2011/058365.

The vacuum cleaner according to claim 1 further comprises a suction blower unit accommodated in or within the cleaner body.

In addition, at least one primary stage cyclone dust separator is provided. The primary stage cyclone dust separator has an air inlet opening which is fluidly coupled to the suction blower unit, in more detail to an outlet opening of the suction blower unit.

In operation, the suction blower unit in general generates a suction effect at an inlet opening to which a suction hose may be coupled. Dust laden air sucked in is blown towards and into subsequent dust separators fluidly connected to the suction blower unit. In the present case the dust separator comprises at least a primary stage cyclone dust separator.

If appropriate, one or more secondary dust separation stages may be provided, favorably arranged downstream the primary stage cyclone dust separator and fluidly connected thereto. The secondary dust separator stages may also be of cyclone type. In a cyclone type dust separator dust is separated from air by a cyclone effect, which is generally known in the state of technology.

The primary stage cyclone dust separator may be provided and adapted to separate coarse dust, debris and other particulate matter from air. Secondary stage cyclone dust separators may be

adapted to separate fine dust from air, in particular dust that either could not be separated in the first stage or that is too fine to be separated in the first stage. Hence, combining several dust separation stages adapted to separate dust particles of different sizes enhances the overall cleaning efficiency.

It shall be noted, that more than two dust separation stages may be combined in series in order to enhance dust separation efficiency. As an example, one of the higher order dust separating steps, e. g. a third dust separation step, may be a filter type separation adapted to retain residual dust particles. Hence, comparatively clean air will be blown out into the environment.

With the vacuum cleaner as proposed in claim 1, in a bottom to top direction the primary stage cyclone dust separator is positioned, or mounted, over, in particular above, the suction blower unit. Note that the term above in particular relates to the bottom to top direction of the cleaner body. Such an arrangement allows a comparatively compact design of the vacuum cleaner, in particular cleaner body, in particular with respect to front to back dimension.

With the proposed vacuum cleaner it is further provided that the air inlet opening and an air outlet opening of the primary stage cyclone dust separator are respectively located towards the back side and front side. This shall mean that the air inlet opening of the primary stage cyclone dust separator is positioned towards the back side, and the dust outlet opening of the primary stage cyclone dust separator is positioned, in particular oriented, towards the front side. This arrangement and implementation of the primary stage cyclone dust separator has been found to enable a compact, yet efficient design.

With the proposed configuration it is possible to implement counterflowing main air streams in the suction blower unit and

primary stage cyclone dust separator. A main air stream in the suction blower unit may be oriented from front to back, whereas an input main air stream between the air inlet opening and dust outlet opening of the primary stage cyclone dust separator may be oriented from back to front. In particular, this type of air guidance and arrangement of suction blower unit and primary stage cyclone dust separator has proven optimal for obtaining comparatively compact design.

10 According to an embodiment of the vacuum cleaner, the suction blower unit comprises a fan coupled to a fan drive motor which, with regard to front to back direction, is installed behind the fan. This in particular means that the fan is positioned towards the front side whereas the drive motor is positioned towards the back side. As the proposed position of the air inlet of the primary stage cyclone dust separator is near or towards the back side, interference between the air inlet opening and fan can be greatly prevented. This, by the way, also contributes to a more compact arrangement of respective components, in particular both in back to front and bottom to top direction. In all, it is possible to compact the arrangement of suction blower unit and primary stage cyclone dust separator.

In a further embodiment of the vacuum cleaner it is provided that in front to back direction or orientation, the air inlet opening of the primary stage cyclone dust separator is arranged and positioned offset and behind the fan. In this configuration a comparatively compact arrangement, in particular with respect to bottom to top and front to back extension can be obtained. Further, interference between air outlet of the fan and air inlet opening of the primary stage cyclone dust separator can be prevented. The air inlet of the primary stage cyclone dust separator may be freely arranged and oriented. Advantageously, the air inlet opening of the primary stage cyclone dust separator is, with respect to the longitudinal extension of the primary

stage cyclone dust separator arranged and oriented tangentially. This in particular supports the build-up of a proper airflow in a cyclone type manner within the primary stage cyclone dust separator.

5

In a further arrangement, an air outlet of the fan and the air inlet opening are fluidly connected to an intermediate air chamber. The air chamber preferably at least partially encompasses and/or encases the fan drive motor. Providing an intermediate
10 air chamber is a comparatively easy way to fluidly connect the fan to the primary stage cyclone dust separator, in particular to pass dust laden air from the fan to the dust separator irrespective of their relative arrangement. Further, and in particular with respect to the arrangement of suction blower and primary stage cyclone dust separator, an optimal usage of space can
15 be obtained, resulting in compact and space saving design.

In one further embodiment it is provided that a dust outlet of the primary stage cyclone dust separator is fluidly connected to
20 a dust collecting chamber. It is of advantage if the dust collecting chamber is positioned and arranged at the front side, in particular immediately at the front side of the vacuum cleaner. In particular with respect to emptying the dust collecting chamber it is, according to a further embodiment, favorable to
25 removably connect or mount the dust collecting chamber to the primary stage cyclone dust separator and/or cleaner body. It may be advantageous if the dust outlet of the primary stage cyclone dust separator is oriented towards the front side.

30 If the dust collecting chamber is positioned at the front side section of the vacuum cleaner it is of particular advantage that at least a translucent inspection window is provided in a front side section of the dust collecting chamber.

In more general terms in accordance with a further embodiment, the dust collecting chamber positioned at the front side may comprise a front side fill level indicator, preferably a translucent or transparent fill level inspection window. In this connection, the term "front side fill level indicator" shall mean that the fill level indicator is accessible and visible at and from the front side of the vacuum cleaner.

The fill level indicator, in particular inspection window, in particular when arranged immediately at the front side, is effective in presenting the filling level of the dust collecting chamber to a user, and will contribute to adequate emptying intervals, which in turn secures optimal cleaning efficiency of the vacuum cleaner. Note that the inspection window may be implemented as a translucent or transparent wall section of the dust collecting chamber.

Providing the dust collecting chamber, and fill level inspection window at the front side in particular leads to simplified and more efficient handling and operability of the vacuum cleaner.

In another embodiment it is provided that the primary stage cyclone dust separator is implemented and installed such that in intended or normal use operation of the vacuum cleaner a main air flow through the primary stage cyclone dust separator is oriented essentially parallel to the front to back or back to front direction, in particular horizontally if operated on a respective ground. Implementing the primary stage cyclone dust separator in such a way leads to a comparatively compact design, in particular with respect to bottom to top dimensions.

In the previous embodiment, the primary stage cyclone dust separator is designed such that a cyclone type dust separating air flow, i. e. a main air flow direction, is oriented from back to front. In this way, dust particles, debris and other particulate

matter removed in the primary stage can be best conveyed to the dust outlet opening provided at and towards the front side. In addition, the primary stage cyclone dust separator preferably is implemented such that a backflow of dust unladen air takes place
5 in the center region of the primary stage cyclone dust separator and is oriented from front to back.

The dust unladen air exiting the primary stage dust separator may be fed into a further separating step or stage, such as for
10 example a secondary stage cyclone dust separator and/or a filter unit. Secondary stage cyclone dust separator and/or filter may be adapted to remove comparatively fine dust, debris and particulate matter not discharged in the primary stage.

15 In a preferred further embodiment, a dust collecting volume of the dust collecting chamber is, with regard to top to bottom, arranged and positioned below the outlet of the primary stage cyclone dust separator. Preferably, a major dust collecting volume of the dust collecting chamber is positioned below the pri-
20 mary stage cyclone dust separator, and more preferably is level or essentially level with the suction blower unit, in particular fan and fan drive motor.

The dust collecting chamber may be positioned at the front side
25 of the vacuum cleaner, and, with respect to a back to front orientation, in front of the suction blower unit. Such a configuration in particular leads to a comparatively compact bottom to top design and also allows efficient dust collecting.

30 In a refinement embodiment of the vacuum cleaner, it is provided that an angle of inclination, i. e. a gradient angle, between the main flow direction of the primary stage cyclone dust separator, in normal operation mode essentially corresponding to the vertical direction, and a center or main axis of the dust col-
35 lecting chamber lies in the range between 40 and 80 degrees,

preferably 60 degrees. Arranging or positioning the dust collecting chamber in accordance with the proposed angle or angular range in particular means that, with regard to bottom to top direction, the main axis of the dust collecting chamber is tilted
5 against the vertical direction towards the back side by an angle between 10 and 50 degrees, preferably 30 degrees. The proposed tilt angle leads to a configuration in which, with regard to front to back direction, in particular horizontal direction, the top section of the dust collecting chamber is closer to the primary stage cyclone dust separator, in particular dust outlet,
10 than a bottom section of the dust collecting chamber.

The proposed geometry in particular allows a compact design, efficient dust collection and optimal bidirectional airflow in the
15 primary stage cyclone dust separator. Further, the tilted arrangement of the dust collection chamber has the advantage that a fill level inspection window or the like arranged at the front side faces upwards and can readily be inspected by a user standing in front of the vacuum cleaner.

20
In a further embodiment, the primary stage cyclone dust separator and, where applicable, the dust collecting chamber, are centered about a back to front vertical center plane of the cleaner body. The term back to front vertical plane shall mean a center
25 plane which is parallel to the vertical direction, more specifically parallel to the bottom to top and top to bottom direction respectively, and which is parallel to the back to front and front to back direction, respectively. Such an arrangement allows a comparatively compact design with respect to the lateral
30 dimension, i. e. the dimension perpendicular to back to front and front to back direction.

In a further embodiment, the vacuum cleaner comprises at least one secondary stage cyclone dust separator installed downstream
35 the primary stage cyclone dust separator. The at least one sec-

ondary stage cyclone dust separator may be positioned or placed, in lateral direction, closely to the primary stage cyclone dust separator and/or dust collection chamber. A secondary cyclone dust separating stage may lead to a higher separating efficiency

5

Exemplary embodiments will now be described in connection with the annexed figures, in which:

Fig. 1 shows a perspective view of a vacuum cleaner;

10

Fig. 2 shows a perspective front view of the vacuum cleaner; and

Fig. 3 and 4 show cross sectional views of the vacuum cleaner;

15

Fig. 1 shows a perspective view of a vacuum cleaner 1. The vacuum cleaner 1 comprises a horizontal type cleaner body 2 with a bottom 3, top 4, front 5 and back side 6. The term horizontal type shall mean that in the ordinary and intended position of use on a corresponding underground, the cleaner body 2 is positioned essentially horizontally, or in more general terms, is positioned essentially parallel to the ground underneath. Note that in the figures, the vacuum cleaner is shown in its ordinary horizontal use position.

25

The vacuum cleaner 1 comprises a primary stage cyclone dust separator 7. The primary stage cyclone dust separator 7 is coupled to a dust collecting chamber 8. The dust collecting chamber 8, which may also be designated as a dust collecting container, is positioned and arranged at the front side 5 of the cleaner body 2. In a front side section, the dust collecting chamber 8 has a fill level indicator, which in the present case is implemented as a transparent wall section arranged and visible from the front. In one implementation, essentially the whole dust col-

35

lecting container, at least walls at the front side, are made from a transparent material. Here, a user can easily observe the fill level of the dust collecting container 8, recognize inadequately high filling levels and, as a consequence, will timely empty the dust container.

The vacuum cleaner 1 comprises wheels 9 arranged at/in or on the lateral side walls and bottom side of the cleaner body 2, respectively. The wheels 9 are arranged and adapted such that the vacuum cleaner 1 during normal and ordinary operation can be easily moved on the surface underneath. The vacuum cleaner 1 may comprise other elements, such as handles and the like, which will not be described in further detail.

At the front side 5 of the vacuum cleaner 1, an interface 10 is provided which is adapted and configured to connect a flexible suction hose (not shown).

Further details of the vacuum cleaner will become apparent in connection with Fig. 2 to Fig. 4.

As can be seen from the vertical plane cross sectional view in Fig. 3, the primary stage cyclone dust separator 7 has an air inlet opening 11 adapted to feed air, in particular dust laden air, into the primary stage cyclone dust separator 7.

The vacuum cleaner 1 further comprises a suction blower unit 12 which comprises an electric drive motor 13 which is coupled to a fan 14. The suction blower 12, in more detail the fan 14, generates, when driven by the drive motor 13, a suction force at the interface 10. If a suction hose is coupled to the interface 10, the suction force propagates through the hose and finally is effective at a nozzle end of the hose.

In operation, the fan 14 sucks in air and forces, i. e. blows, the air towards the primary stage cyclone dust separator 7. In the present case, in between a fan outlet (not explicitly shown) and the air inlet opening 11 of the primary stage dust cyclone dust separator 7 there is provided an intermediate air chamber 16. The fan 14 and the primary stage cyclone dust separator 7 are fluidly connected to the intermediate chamber 16 such that an airflow between fan 14 and primary stage cyclone dust separator 7 is possible.

10

Note that a fluid connection between the fan 14 and primary stage cyclone dust separator 7 may be implemented in any other way, without an intermediate chamber 16. In particular, any type of ducting may be used to fluidly connect the air outlet of the fan 14 to the air inlet opening 11 of the primary stage cyclone dust separator 7. If adequate, it may also be considered to directly connect the air outlet 14 to the air inlet opening 11.

15

The arrangement and design of the suction blower unit 12 is such that in bottom to top direction, i. e. in a direction from the bottom side 3 to the top side 4, the primary stage cyclone dust separator 7 is positioned over the suction blower unit 12. This can be seen best from Fig. 3, where a section of the primary stage cyclone dust separator 7, oriented towards the back side 6 of the vacuum cleaner 1, is positioned over, in more detail above, the suction blower unit 12. Such an arrangement in particular allows a space saving design.

20

25

The primary stage cyclone dust separator 7 is arranged and implemented such that the air inlet opening 11 is located at a back side end section of the primary stage cyclone dust separator 7. The air inlet opening 11 is presently arranged at some distance above the drive motor 13.

30

With regard to front to back direction, the air inlet opening 11 is arranged and located offset and behind the fan 14. The aperture of air inlet opening 11 of the primary stage cyclone dust separator 7 in the present case is oriented and directed laterally, i. e. sideways, which greatly contributes to the build up of a cyclonic, dust separating airflow within the primary stage cyclone dust separator 7.

At the front side end of the primary stage cyclone dust separator 7, in particular near or at a lower part of the front side face side of the primary stage cyclone dust separator 7, there is provided a dust outlet opening 17. The dust outlet opening 17 is positioned and adapted such that dust, debris and other particulate matter separated in the primary stage cyclone dust separator 7 is forced towards and unloaded at or near the dust outlet opening 17.

The dust outlet opening 17 is connected, i. e. opens into, the dust collecting chamber 8 in which dust and the like is collected. The dust outlet opening 17 may be coupled to a corresponding dust inlet opening (not shown) of the dust collecting chamber 8. An intermediate seal to be positioned between the openings may be provided to avoid escape of dust at the transition between primary stage cyclone dust separator 7 and dust collecting chamber 8.

Dust unladen air leaves the primary stage cyclone dust separator 7 via an air outlet section 18. Note that the air flow within the vacuum cleaner is indicated by dotted arrows in Fig. 3.

In general it can be seen from Fig. 3, that the primary stage cyclone dust separator 7 is implemented and installed such that in intended use operation, as shown throughout Fig. 1 to Fig. 3, a main air flow through the primary stage cyclone dust separator

7 is oriented essentially horizontally, presently corresponding to front to back and back to front directions.

Air leaving the primary stage cyclone dust separator 7 may be discharged to the environment. However, for the reason of more efficient dust removal it may be desirable to provide one or several further, in particular secondary, dust removing stages downstream the primary stage dust cyclone separator 7. The secondary stages may be of cyclone type and/or filter type.

10

With the vacuum cleaner 1 as shown and described in connection with Fig. 1 to 3, it may be provided that the dust collecting chamber 8 together with the primary stage cyclone dust separator 7 are removably connected to the cleaner body 2. It may be provided that both parts can be removed as a whole from the cleaner body 2. However, it is also possible, that the primary stage cyclone dust separator 7 and/or the dust collecting chamber 8 are handleable as separate parts, i. e. that they can be mounted and removed independently from each other.

20

With the embodiments shown in the Figures, it can be seen, that the primary stage cyclone dust separator 7 works with a horizontal air flow, which is advantageous for a space saving design. Further, it can be seen that, with regard to top to bottom direction, at least a main part of the dust collecting chamber 8 is arranged below the dust outlet opening 17 and/or primary stage cyclone dust separator 7. Such an arrangement is a comparatively good compromise between space saving/compact design and high dust separating efficiency in the primary stage cyclone dust separator 7.

30

In particular with respect to dust separating efficiency, and also with respect to comfortable operation of the vacuum cleaner 1 it has been proven advantageous to tilt the dust collecting chamber 8 against the primary stage cyclone dust separator 7.

35

With particular reference to Fig. 4, it can be seen that with regard to the back to front direction a center axis 19 of the dust collecting chamber 8 is tilted downwards by an angle α of about 60 degrees. In other words, an angle spanned between back side of the primary stage cyclone dust separator 7, front side of the primary stage cyclone dust separator 7 and bottom of the dust collecting chamber 8 amounts $180^\circ - \alpha$, i. e. 120 degrees. Note that the tilt angle α may lie in the range from 40 to 80 degrees. The adjacent angle $180^\circ - \alpha$ therefore may lie in the range from 100 to 140 degrees. Such tilt angles have been proven to be efficient in dust deposition within the dust collecting chamber 8, and to provide a good visibility of the fill level of the dust collecting chamber 8 from a position in front of the vacuum cleaner 1.

As can in particular be seen from Fig. 1 and Fig. 2, the primary stage cyclone dust separator 7 and dust collecting chamber 8 are centered about a back to front vertical center plane of the cleaner body 2. In other words the primary stage cyclone dust separator 7 and dust collecting chamber 8 are centered with regard to the lateral dimension of the cleaner body 2. Such an arrangement allows a comparatively compact overall design and efficient air flow. Remaining space not occupied from the elements mentioned so far can advantageously be used for positioning additional elements, such as grips and handles or stowage compartments for accessories, and others.

In all, it can be seen, that the proposed vacuum cleaner provides a compact design, enhanced usability and satisfactory cleaning efficiency.

List of reference numerals

- 1 vacuum cleaner
- 2 cleaner body
- 3 bottom side
- 4 top side
- 5 front side
- 6 back side
- 7 primary stage cyclone dust separator
- 8 dust collecting chamber
- 9 wheel
- 10 interface
- 11 air inlet opening
- 12 suction blower unit
- 13 drive motor
- 14 fan
- 16 intermediate air chamber
- 17 dust outlet opening
- 18 air outlet section
- 19 center axis

Claims

1. Vacuum cleaner (1) comprising a horizontal type cleaner body (2) with a bottom (3), top (4), front (5) and back side (6), a suction blower unit (12) accommodated in the cleaner body (2) and at least one primary stage cyclone dust separator (7) having an air inlet opening (11) fluidly coupled to the suction blower unit (12), wherein in bottom to top direction the primary stage cyclone dust separator (7) is positioned over the suction blower unit (12), and wherein the air inlet opening (11) and a dust outlet opening (17) of the primary stage cyclone dust separator (7) are located towards the back side (6) and front side (5) respectively.
2. Vacuum cleaner (1) according to claim 1, wherein the suction blower unit (12) comprises a fan (14) coupled to a fan drive motor (13) which, in front to back direction, is installed offset and behind the fan (14).
3. Vacuum cleaner (1) according to any of claims 1 and 2, wherein, in front to back direction, an air inlet opening (11) of the primary stage cyclone dust separator (7) is offset and arranged behind the fan (14).
4. Vacuum cleaner (1) according to claim 3, wherein an air outlet of the fan (14) and the air inlet opening (11) are fluidly connected to an intermediate air chamber (16), preferably at least partially encompassing the fan drive motor (13).
5. Vacuum cleaner (1) according to any of claims 1 to 4, wherein a dust outlet (17) of the primary stage cyclone dust separator (7) is fluidly connected to a dust collecting chamber (8) which is arranged at the front side (5).

6. Vacuum cleaner (1) according to claim 5, wherein the dust collecting chamber (8) is removably connected to the primary stage cyclone dust separator (7) and/or cleaner body (2).
- 5 7. Vacuum cleaner (1) according to any of claims 5 and 6, wherein the dust collecting chamber (8) comprises at the front side (5) a fill level indicator, preferably a translucent, in particular transparent, fill level inspection window.
- 10 8. Vacuum cleaner (1) according to any of claims 5 to 7, wherein the primary stage cyclone dust separator (7) is implemented and installed such that in intended use operation main air flow through the primary stage cyclone dust separator (7) is oriented essentially parallel to front to back or
15 back to front direction.
9. Vacuum cleaner (1) according to any of claims 5 to 8, wherein with regard to top to bottom direction, a dust collecting
20 volume of the dust collecting chamber (8) is at least partially arranged below the dust outlet opening (17) of the primary stage cyclone dust separator (7).
10. Vacuum cleaner (1) according to any of claims 5 to 9, wherein
25 in an angle of inclination between main air flow direction through the primary stage cyclone dust separator (7) and a center axis of the dust collecting chamber (8) lies in the range between 40 and 80 degrees.
- 30 11. Vacuum cleaner (1) according to claim 9, wherein the angle of inclination is of about 60 degrees.
12. Vacuum cleaner (1) according to any of claims 1 to 11, wherein the primary stage cyclone dust separator (7) and,
35 where applicable, dust collecting chamber (8), are centered

about a back to front vertical center plane of the cleaner body (2).

- 5 13. Vacuum cleaner (1) according to any of claims 1 to 12, further comprising at least one secondary stage cyclone dust separator installed downstream the primary stage cyclone dust separator (7).

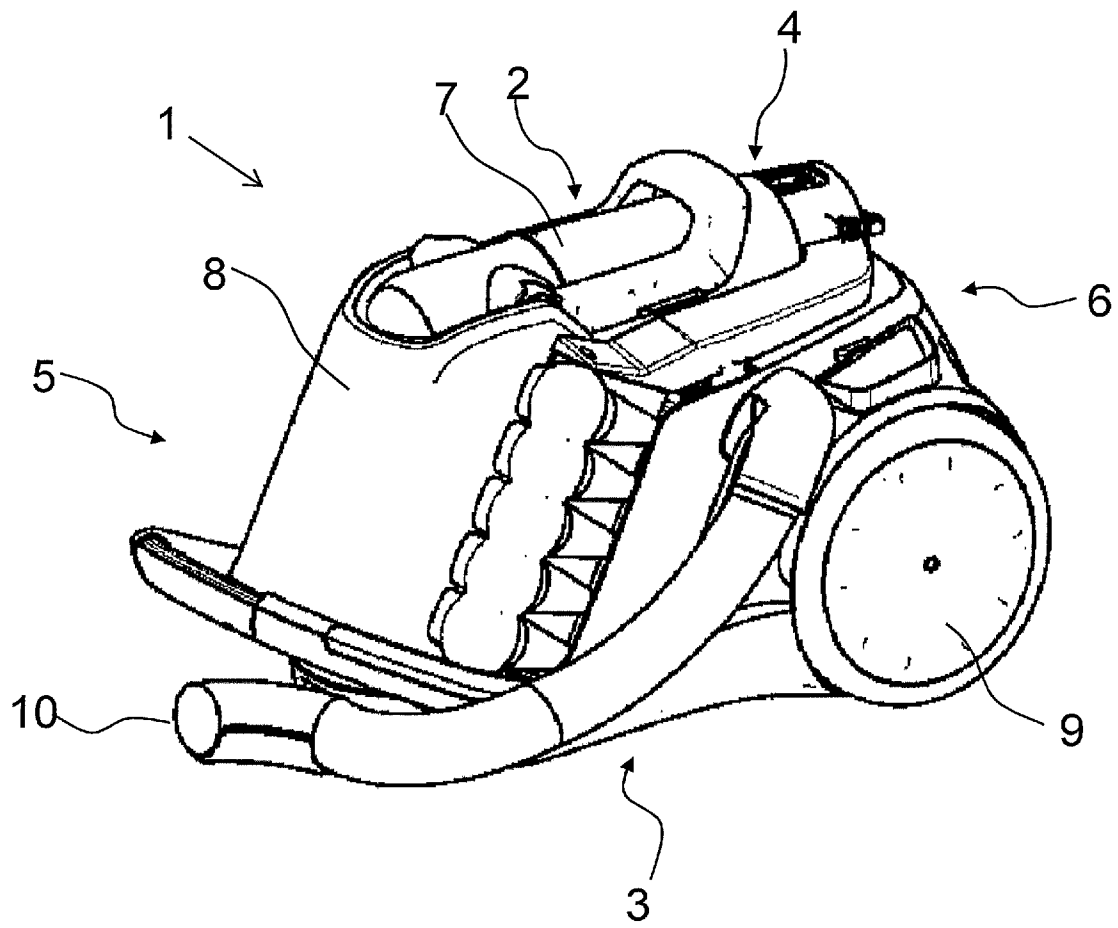

Fig. 1

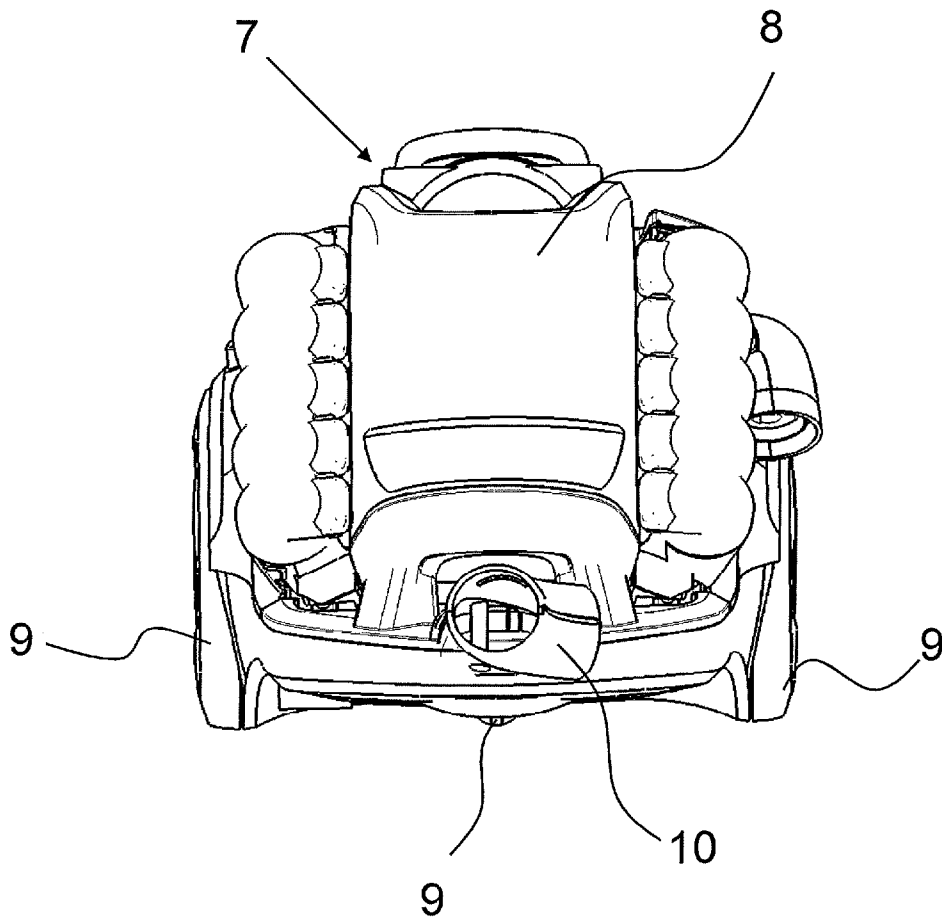

Fig. 2

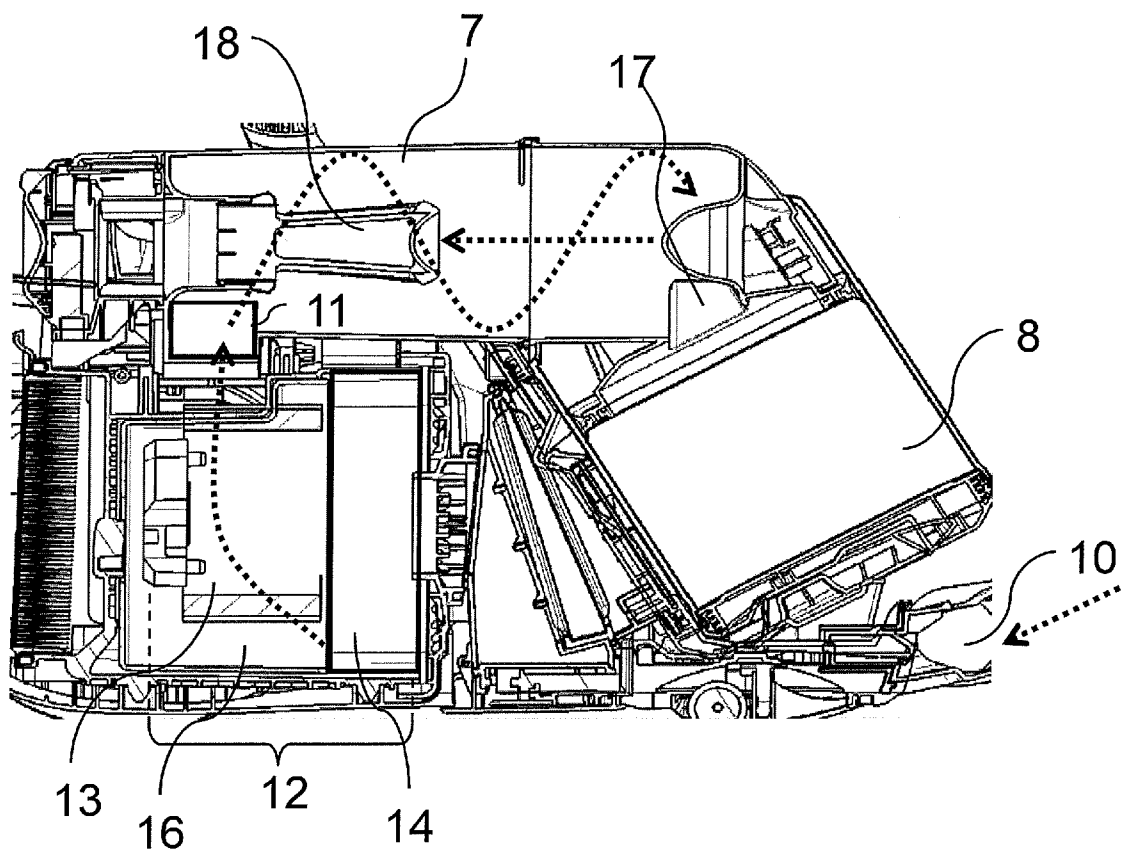

Fig. 3

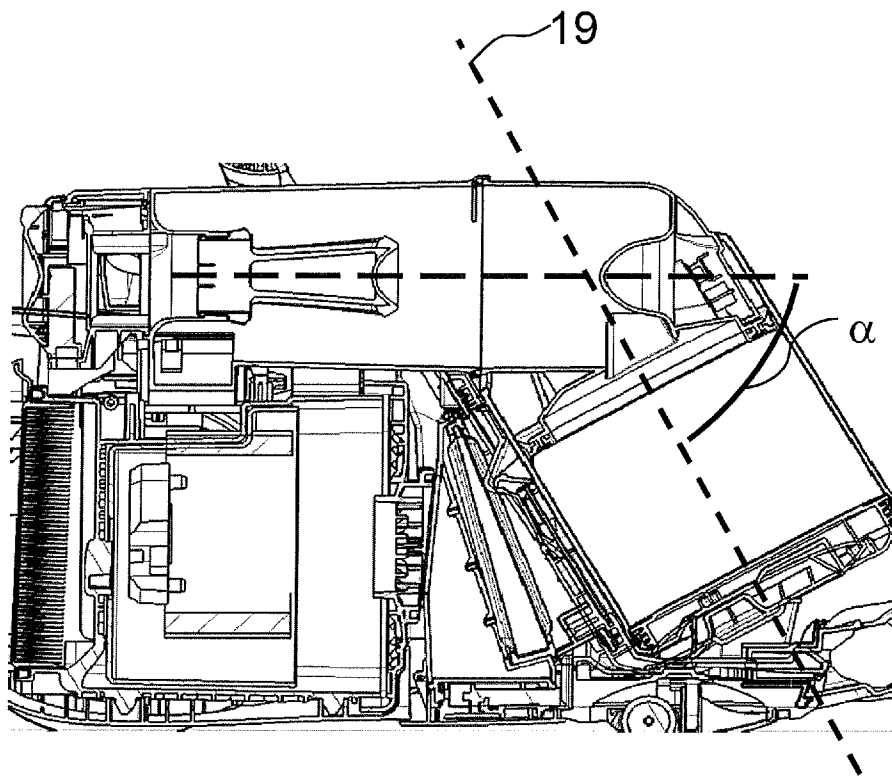

Fig. 4

INTERNATIONAL SEARCH REPORT

International application No
PCT/EP2012/053025

A. CLASSIFICATION OF SUBJECT MATTER
INV. A47L9/10 A47L9/00
ADD.
According to International Patent Classification (IPC) or to both national classification and IPC

B. FIELDS SEARCHED
Minimum documentation searched (classification system followed by classification symbols)
A47L

Documentation searched other than minimum documentation to the extent that such documents are included in the fields searched

Electronic data base consulted during the international search (name of data base and, where practicable, search terms used)
EPO-Internal

C. DOCUMENTS CONSIDERED TO BE RELEVANT

Category*	Citation of document, with indication, where appropriate, of the relevant passages	Relevant to claim No.
A	JP 2007 125294 A (SHARP KK) 24 May 2007 (2007-05-24) abstract; figures 1,3,5 -----	1-13
A	US 6 502 277 B1 (PETERSSON STEFAN [SE] ET AL) 7 January 2003 (2003-01-07) abstract; figures 2,3,4 -----	1-13
A,P	JP 2011 245236 A (MITSUBISHI ELECTRIC CORP; MITSUBISHI ELECTRIC HOME APPL) 8 December 2011 (2011-12-08) abstract; figure 1 -----	1-13

Further documents are listed in the continuation of Box C.

See patent family annex.

* Special categories of cited documents :

- "A" document defining the general state of the art which is not considered to be of particular relevance
- "E" earlier application or patent but published on or after the international filing date
- "L" document which may throw doubts on priority claim(s) or which is cited to establish the publication date of another citation or other special reason (as specified)
- "O" document referring to an oral disclosure, use, exhibition or other means
- "P" document published prior to the international filing date but later than the priority date claimed

- "T" later document published after the international filing date or priority date and not in conflict with the application but cited to understand the principle or theory underlying the invention
- "X" document of particular relevance; the claimed invention cannot be considered novel or cannot be considered to involve an inventive step when the document is taken alone
- "Y" document of particular relevance; the claimed invention cannot be considered to involve an inventive step when the document is combined with one or more other such documents, such combination being obvious to a person skilled in the art
- "&" document member of the same patent family

Date of the actual completion of the international search
15 May 2012

Date of mailing of the international search report
30/05/2012

Name and mailing address of the ISA/
European Patent Office, P.B. 5818 Patentlaan 2
NL - 2280 HV Rijswijk
Tel. (+31-70) 340-2040,
Fax: (+31-70) 340-3016

Authorized officer
Blumenberg, Claus

INTERNATIONAL SEARCH REPORT

Information on patent family members

International application No

PCT/EP2012/053025

Patent document cited in search report	Publication date	Patent family member(s)	Publication date
JP 2007125294	A	24-05-2007	NONE
US 6502277	B1	07-01-2003	DE 60033986 T2 29-11-2007
			EP 1042981 A2 11-10-2000
			EP 1683462 A1 26-07-2006
			SE 512295 C2 28-02-2000
			SE 9901252 A 28-02-2000
			US 6502277 B1 07-01-2003
JP 2011245236	A	08-12-2011	NONE