

Oct. 31, 1950

J. D. WALKER

2,528,094

FLOW-ENERGY MIXING TANK

Filed Dec. 12, 1946

2 Sheets-Sheet 1

Fig-1

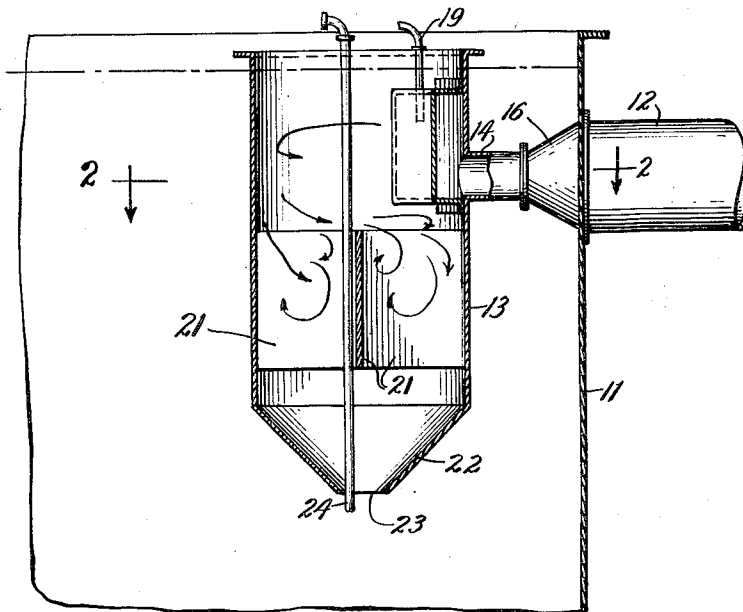
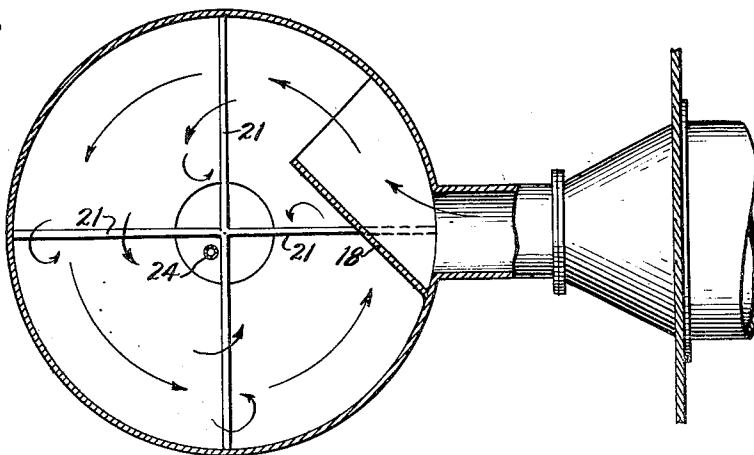

Fig-2



Inventor

James Donald Walker

By:

Louis Robertson

Att. l.

Oct. 31, 1950

J. D. WALKER

2,528,094

FLOW-ENERGY MIXING TANK

Filed Dec. 12, 1946

2 Sheets-Sheet 2

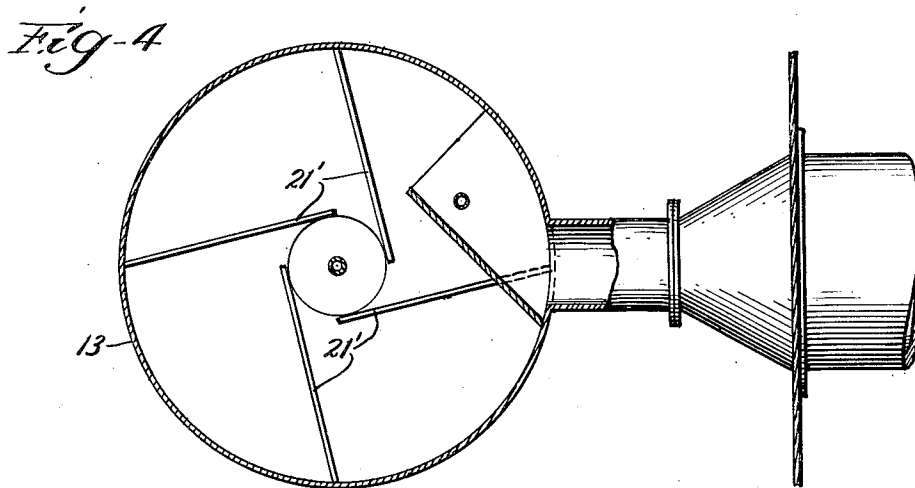
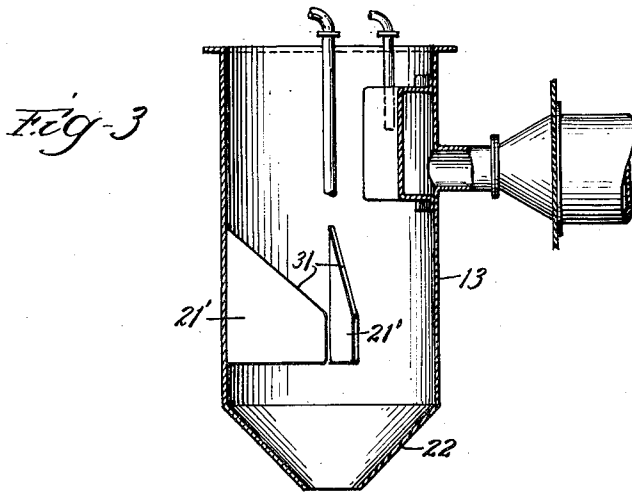

Inventor
James Donald Walker
By
Louis Robertson
Att.

UNITED STATES PATENT OFFICE

2,528,094

FLOW-ENERGY MIXING TANK

James Donald Walker, Aurora, Ill., assignor to
Walker Process Equipment, Inc., Aurora, Ill., a
corporation of Illinois

Application December 12, 1946, Serial No. 715,754

3 Claims. (Cl. 259-4)

1

In water treatment it is often important to obtain a very thorough mixing of one or more chemicals with the liquid being treated. Heretofore, this has usually been accomplished by providing impellers or paddles or the like in the mixing compartment, and providing a special motor for driving them. According to the present invention a mixing unit is provided which relies solely upon the energy of the incoming liquid, the mixing unit including an arrangement of baffles which cooperate to obtain very satisfactory mixing of the liquid with the chemicals.

Although extra pumping may be required in order to supply the energy consumed by the mixing unit, such extra pumping can usually be supplied fairly economically. Pumps now are highly developed, are quite efficient, and are made in large quantities so that their cost is reasonable. According to the present invention no special moving parts are required, only stationary elements, such as baffles, which are easily manufactured and installed in the small quantities required by this field of work, and which obviously cannot be the source of bearing troubles or the like.

Additional objects and advantages of the invention will be apparent from the following description and from the drawings in which:

Fig. 1 is a somewhat diagrammatic view representing a fragmentary vertical cross-section through a flocculating tank, showing the mixing unit of the present invention therein;

Fig. 2 is a fragmentary horizontal cross-sectional view taken approximately on the line 2-2 of Fig. 1.

Fig. 3 is a view corresponding somewhat to Fig. 1 but showing a modified form of baffles;

Fig. 4 is a view similar to Fig. 2 but showing the baffles of Fig. 3.

Although the law requires a full and exact description of at least one form of the invention, such as that which follows, it is, of course, the purpose of a patent to cover each new inventive concept therein no matter how it may later be disguised by variations in form or additions of further improvements; and the appended claims are intended to accomplish this purpose by particularly pointing out the parts, improvements, or combinations in which the inventive concepts are found.

Both forms of the invention have been shown in conjunction with a large tank 11, which may be a flocculating and settling tank, and a liquid supply pipe 12 for supplying water to be softened or other liquid to be treated. The invention in-

2

cludes a mixing tank 13 which may be supported within the main tank 11 in any convenient manner. Of course, it could be outside the main tank, but the position illustrated is preferred. The tank 13 is provided with an inlet connection 14, which in turn is provided with a reducing connection 16 to connect the pipe 14 with the pipe 12. The pipe 14 should be enough smaller than the pipe 12 so that the speed of flow through the pipe 12 will be approximately ten feet per second, and certainly not less than six feet per second. A full ten feet per second is preferred. In water mains or supply pipes, such as 12, water usually flows at a maximum rate of about four feet per second.

In front of the inlet pipe 14, a deflecting baffle 18 is provided as seen best in Fig. 2. This causes the water to enter the tank 13 in a generally tangential direction, which in turn produces a generally circular movement of the water in the upper or inlet zone of tank 13. A chemical supply pipe 19 is positioned to feed to the incoming water a chemical to be mixed therewith. Positioned somewhat below the inlet connection 14 in the tank 13 are baffles 21. If only clear water is to be treated the baffles are preferably in the form of a star baffle with four arms extending radially from the center of the tank to the side walls of the tank as seen best in Fig. 2. When the volume of water moving downwardly with a generally circular or spiral movement strikes the baffles 21, the generally circular or spiral flow will be transformed into a highly turbulent flow with a general movement longitudinally of the tank. The high turbulence will cause a thorough mixing of the chemical supply through the supply pipe 13 with the water.

The lower part of the tank 13 is preferably provided with a converging or conical wall 22, having an opening 23 therein, which is small enough so that the flow downwardly there-through will be at a sufficiently high average rate so that substantially no water which once passes down through the opening 23 will be swept back into the tank 13 with the eddy currents.

A second chemical may be added to the water through the pipe 24 as the water leaves the tank 13. In the case of softening water it is desirable that the final precipitating chemical, such as lime soda, be mixed at this point so that the precipitation will take place in the main tank 11. In this way the tank 13 will stay relatively clean and relatively free from the hard deposit which otherwise would occasionally have to be chipped off. The thorough mixing of the coagu-

lant from pipe 19 prior to the introduction of the lime soda ensures satisfactory reaction of the lime soda with the hardening constituents in the water so as to remove them. At the same time the residual turbulence in the mixture as it leaves tank 23 ensures adequate mixing of the water with the chemicals from pipe 24. As the mixture leaves the vicinity of tank 13 the turbulence subsides to a mild flocculating turbulence and gradually subsides further to prevent settling.

In case sewage or other waste with stringy material therein is to be treated, the form of baffles shown in Figs. 3 and 4 is preferred. As seen in Fig. 3, the upper edges 31 of the baffles 21' slope away from the outer walls of the tank 13 in the direction of the flow of water. In other words, the slope of the upper edges is downward and away from the walls 13. As seen best in Fig. 4, the baffles 21' are entirely free from one another at their inner ends. In fact, they have been illustrated as entirely free from one another and from all support, except at the outer wall of tank 13. To give them greater rigidity they could be extended down to the conical wall 22. If any bracing is provided, it should be a form of bracing which does not extend across any flow area of the liquid, as stringy material might then catch on such braces. It will be understood that the reason for the sloping upper edges 31 and the freedom of the baffles from braces or supports extending across the flow area is so that no stringy material will find any place to lodge.

In place of the supply pipe 12 and the reducer 16, water could be pumped directly into the inlet pipe 14 at the required higher speed. It will usually be more practical, however, to use a more remotely located pumping station, and in that event a supply pipe 12, larger than the pipe 14, is preferred, inasmuch as the flow of the water at the more conventional speeds of four feet per second, or less, is more economical where any substantial distance is involved.

From the foregoing, it is seen that a mixing unit has been devised which requires no moving parts, but which, nevertheless, thoroughly mixes an incoming liquid with one or more chemicals, which may be gradually fed to the incoming liquid, and also with one or more chemicals which may be gradually fed to the mixture leaving the mixing tank. The energy used to accomplish this mixing is the energy of the incoming liquid. Although moving parts somewhere will ordinarily be required for pumping, there is some advantage in not having these exposed to the mixed chemicals and also in being able to use conventional pumps. Specially designed machinery for a mixing tank is likely to be relatively more expensive than conventional pumps, and especially more expensive than the mere increment of pumping facilities required to supply a given amount of energy for the mixing unit.

I claim:

1. The combination of a flocculating tank and a mixing tank communicating therewith, the mixing tank including an inlet, a converging conduit communicating therewith to connect with a supply pipe larger than the inlet to produce a speeding up of the flow of the liquid, an inlet baffle inside of the mixing tank adapted to im-

part a generally rotary flow to the incoming liquid and baffle means positioned to intercept the main flow between the inlet and outlet of the mixing tank adapted to convert the generally rotary flow resulting from the inlet baffle to a highly turbulent generally longitudinal flow, and said tank including a stilling chamber between the baffles and the outlet for permitting some dissipation of the turbulence and for reducing the flow area of the body so that substantially no liquid having left the mixing tank will flow back into it due to turbulence.

2. A mixing unit including a tank, an inlet connection communicating with the tank near the top thereof and converging toward the tank to speed up the flow of liquid approaching the tank, a deflector inside of the tank in front of the inlet connection disposed at an angle to the inlet axis to impart a generally rotary movement to the incoming stream, a supply pipe opening adjacent the inlet connection for supplying a chemical to the incoming stream to be mixed therewith, a plurality of baffles positioned in the tank below the inlet connection and extending from a peripheral wall of the tank generally toward and close to the center of the tank and into the main path of flow between the inlet means and the outlet whereby the relatively smooth swirling movement of the liquid above the baffles is converted into a high turbulent flow through the passages between the baffles, said tank below the baffles having walls converging toward an opening forming an outlet for the tank, and another container communicating with said outlet and having walls higher than the bottom of said inlet to maintain a pool in said tank at least as high as said inlet.

3. A structure through which liquid flows, having an inlet and an outlet and comprising a peripheral wall between the inlet and outlet and a plurality of baffles each extending from a peripheral wall generally toward the center of the structure and into the main path of flow between the inlet means and the outlet, the upper edges of the baffles sloping from the outer walls in the main direction of liquid movement and the baffles being free from one another and from supports extending across flow areas whereby stringy material will reliably pass through the baffle system.

JAMES DONALD WALKER.

REFERENCES CITED

The following references are of record in the file of this patent:

UNITED STATES PATENTS

Number	Name	Date
489,833	Saxon	Jan. 10, 1893
671,075	White	Apr. 2, 1901
1,157,092	Du Rell	Oct. 19, 1915
1,468,226	Colburn et al.	Sept. 13, 1923
1,625,306	Frattalone	Apr. 19, 1927
1,842,877	Muller et al.	Jan. 26, 1932
1,864,947	Selfridge	June 28, 1932

FOREIGN PATENTS

Number	Country	Date
522,772	Germany	Apr. 14, 1931
529,512	Germany	July 17, 1931