

Nov. 20, 1928.

1,692,765

E. H. SALT

SHEET METAL WASTE PAPER BASKET

Filed July 20, 1927

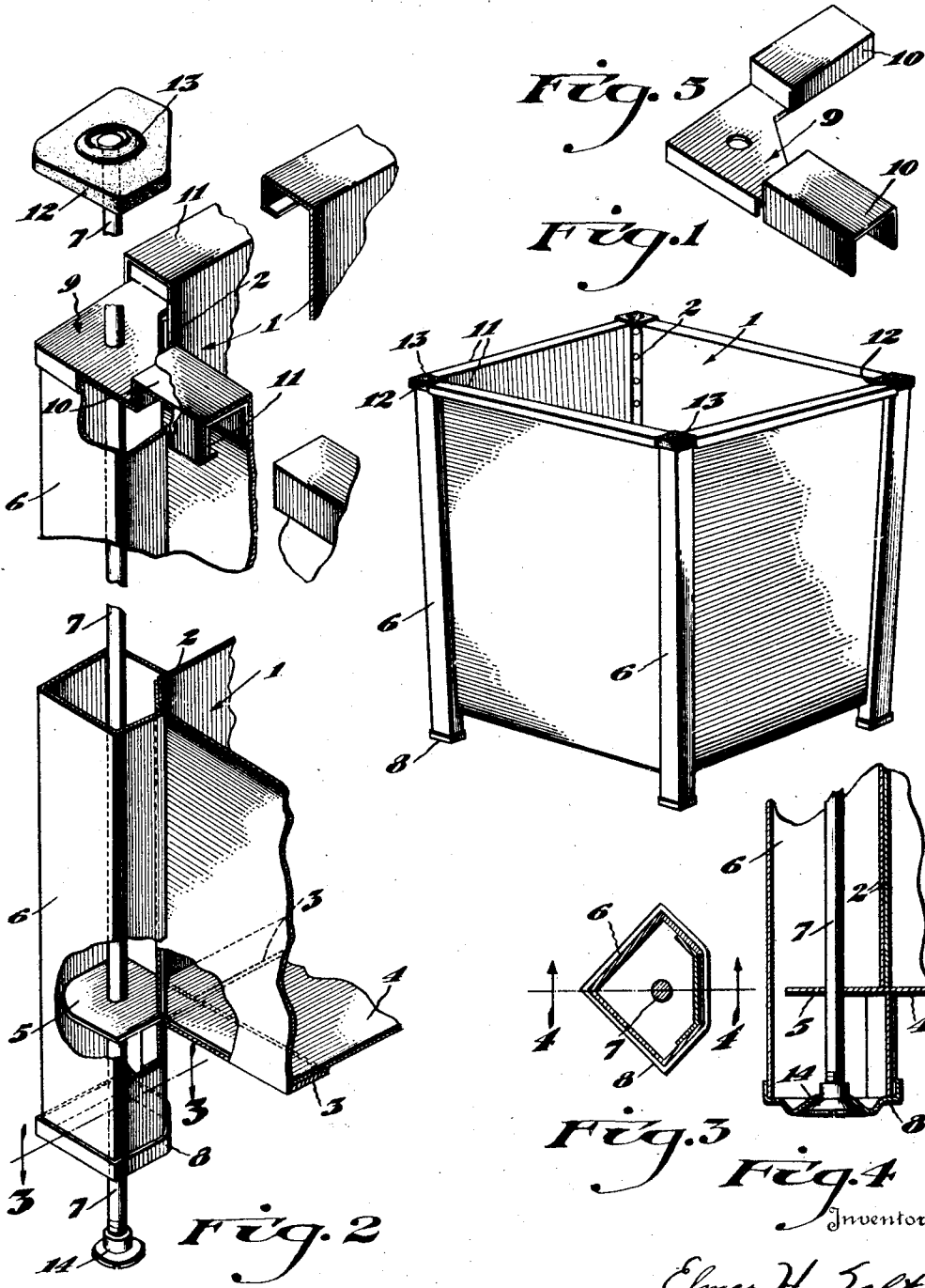

Fig. 5  
Fig. 1

Fig. 3  
Fig. 4  
Inventor

Elmer H. Salt

Word & Word

334

Attorney

# UNITED STATES PATENT OFFICE.

ELMER H. SALT, OF NORWOOD, OHIO, ASSIGNOR TO THE GLOBE-WERNICKE COMPANY,  
OF CINCINNATI, OHIO, A CORPORATION OF OHIO.

## SHEET-METAL WASTE-PAPER BASKET.

Application filed July 20, 1927. Serial No 207,244.

The invention relates to improvements in sheet metal waste paper baskets, and particularly to the corner construction of a rectangular form of basket to provide a very rigid and durable product of enhanced appearance, and which patterns with high quality office and library furniture.

An object of the invention is to provide a sheet metal rectangular receptacle with exterior corner molding giving aesthetic design and structural utility to the body of the receptacle and extending beyond the base of the receptacle to provide legs therefor.

Another object of the invention is to provide a sheet metal rectangular receptacle with the side walls formed of separate sheets of metal having flanged ends overlappingly joined together forming reinforced beveled corners.

Another object of the invention is to provide a sheet metal rectangular receptacle with angle corners braces for the upper end telescopically engaged into the rim beading of the side walls, and providing a socket or pocket for a bumper having its edges extending beyond the rim of the body of the receptacle.

Another object of the invention is to provide a sheet metal receptacle with corner molding and corner braces with the molding and braces for each corner secured to the body by a single tie rod extending longitudinally through the molding.

Other features and advantages of the invention will be more fully set forth in the description of the accompanying drawings, forming a part of this specification, in which:

Figure 1 is a perspective view of the improved basket.

Figure 2 is a perspective view of a corner of the basket, the various parts of the metal being broken away and the view being otherwise broken up to fully illustrate the construction of a corner and the manner in which the metal of the various parts is turned.

Figure 3 is a sectional view taken on line 3—3, Figure 2, detailing the construction of a leg of the basket.

Figure 4 is a sectional view taken on line 4—4, Figure 3, showing the manner in which a corner of the bottom of the basket is mounted within the general corner construction.

Figure 5 is a perspective view of a top corner plate.

Referring to the drawings, 1 indicates the

body of the basket with its side walls formed of separate sheets of metal welded together at its corners. Each side wall has at its opposite longitudinal ends inwardly bent corner flanges 2, the flanges joining the walls by overlapping each other and spot-welded together. This construction forms a double wall bevel corner for the body giving to the interior of the basket, and provides a wall clearance as a facility in spot-welding the flanges centrally for their length. The double wall thickness and bevel reinforces the body at the corners, enabling the walls to be made of comparatively thin gauge sheet metal.

The walls at their lower edge are marginally angle flanged inwardly providing a ledge 3 upon which a flat sheet metal bottom 4 is sustained and spot-welded thereto. Tubular corner molding strips 6 of rectangular design in cross section fit over the beveled corners being split for the full length of the body so as to abuttingly engage the side walls along the line of the corner flange bends, and at their lower ends extend beyond the base of the body forming legs for the basket.

The bottom at each of its corners has a tab 5 extending therefrom in plane with the bottom and extends through the split portion of the molding so as to be engaged within the molding. The tab 5 secures the corner molding to the base of the body by means of a rod 7 which extends centrally through the molding. A leg socket or shoe 8 as a sheet metal stamping is engaged over the lower or leg end of the molding and provides an end plate for the lower end of the tie rod 7 which engages through an aperture in the socket.

The tie rod at the upper end of the corner molding engages through a corner bracket or brace 9 comprising a sheet metal angle stamping having its body portion edge flanged at its lower side forming a socket for engaging over the upper end of the corner molding and provided with channel formed extensions 10—10 telescopically engaged into the ends of a rectangular beading crimp 11 formed by outwardly bending the upper edge of the side walls.

The central or body portion of the corner brace is recessed or depressed from the upper plane of the channel extensions to form a pocket for a resilient bumper 12 held in place by the tie rod and a countersunk washer 13 engaged upon the bumper and

bearing against the head end of the tie rod. The outer edges of the bumper extend beyond the body portion of the corner brace and corner molding to guard or protect the upper corners of the basket against bumping or marring any surfaces with which it may be brought into contact.

The tie rod 7 at its lower end carries a sleeve nut 14 screw-threaded thereon engaging into a countersunk embossing in the leg socket 8. The tie rod thus secures the socket 8 to the lower end of the molding and the molding to the tab extension of the body base, and the upper end of the molding to the angle or corner brace, and the bumper in position upon the corner brace so that all of the parts are held in position by a single screw rod.

Having described my invention, I claim:

A sheet metal waste paper basket, comprising a body of sheet metal, side walls, the walls at their upper ends each bent into a hollow rim open at opposite ends, a corner brace, one for each corner engaged into the end of the rims of adjoining walls, tubular molding engaged longitudinally over each of the corners of said body and providing legs therefor, each corner molding at its upper end socketed into a respective corner brace and at the base of the body engaged over an extension thereof, and a rod for each corner extending longitudinally through the molding and engaged with said corner brace and base extension.

In witness whereof, I hereunto subscribe my name.

ELMER H. SALT.