



## INTERNATIONAL APPLICATION PUBLISHED UNDER THE PATENT COOPERATION TREATY (PCT)

<p>(51) International Patent Classification<sup>5</sup> : G01N 33/28, 21/64</p>	<p>A1</p>	<p>(11) International Publication Number: <b>WO 94/12874</b></p> <p>(43) International Publication Date: 9 June 1994 (09.06.94)</p>
<p>(21) International Application Number: PCT/GB93/02408</p> <p>(22) International Filing Date: 23 November 1993 (23.11.93)</p> <p>(30) Priority Data:  9224936.6            27 November 1992 (27.11.92)    GB  9317930.7            26 August 1993 (26.08.93)        GB</p> <p>(71) Applicant (for all designated States except US): BP OIL INTERNATIONAL LIMITED [GB/GB]; Britannic House, 1 Finsbury Circus, London EC2M 7BA (GB).</p> <p>(72) Inventor; and  (75) Inventor/Applicant (for US only): THEOCHAROUS, Evangelos [GB/GB]; 3 Sunna Gardens, Sunbury-on-Thames, Middlesex TW16 5EE (GB).</p> <p>(74) Agent: PREECE, Michael; BP International Limited, Patents &amp; Agreements Division, Chertsey Road, Sunbury-on-Thames, Middlesex TW16 7LN (GB).</p>		<p>(81) Designated States: AU, BG, CA, CZ, HU, JP, KR, KZ, LV, MW, NZ, PL, RO, RU, SK, UA, US, European patent (AT, BE, CH, DE, DK, ES, FR, GB, GR, IE, IT, LU, MC, NL, PT, SE).</p> <p><b>Published</b>  <i>With international search report.</i></p>
<p>(54) Title: METHOD OF IDENTIFYING LIQUID PETROLEUM PRODUCTS</p>		
<p>(57) Abstract</p> <p>A method of identifying a liquid petroleum product using a device comprising a laser source and a means for detecting a fluorescent signal comprising (a) a first step of adding to the liquid petroleum product a material capable of fluorescing in the far red or near infrared region of the spectrum; (b) a second step of exposing the liquid petroleum product obtained in the first step to the laser source at a wavelength in the far red or near infra region of the spectrum suitable for exciting the material; (c) determining the presence of the material in the liquid petroleum product by determining the fluorescence signal.</p>		

*FOR THE PURPOSES OF INFORMATION ONLY*

Codes used to identify States party to the PCT on the front pages of pamphlets publishing international applications under the PCT.

AT	Austria	GB	United Kingdom	MR	Mauritania
AU	Australia	GE	Georgia	MW	Malawi
BB	Barbados	GN	Guinea	NE	Niger
BE	Belgium	GR	Greece	NL	Netherlands
BF	Burkina Faso	HU	Hungary	NO	Norway
BG	Bulgaria	IE	Ireland	NZ	New Zealand
BJ	Benin	IT	Italy	PL	Poland
BR	Brazil	JP	Japan	PT	Portugal
BY	Belarus	KE	Kenya	RO	Romania
CA	Canada	KG	Kyrgystan	RU	Russian Federation
CF	Central African Republic	KP	Democratic People's Republic of Korea	SD	Sudan
CG	Congo	KR	Republic of Korea	SE	Sweden
CH	Switzerland	KZ	Kazakhstan	SI	Slovenia
CI	Côte d'Ivoire	LI	Liechtenstein	SK	Slovakia
CM	Cameroon	LK	Sri Lanka	SN	Senegal
CN	China	LU	Luxembourg	TD	Chad
CS	Czechoslovakia	LV	Latvia	TG	Togo
CZ	Czech Republic	MC	Monaco	TJ	Tajikistan
DE	Germany	MD	Republic of Moldova	TT	Trinidad and Tobago
DK	Denmark	MG	Madagascar	UA	Ukraine
ES	Spain	ML	Mali	US	United States of America
FI	Finland	MN	Mongolia	UZ	Uzbekistan
FR	France			VN	Viet Nam
GA	Gabon				

METHOD OF IDENTIFYING LIQUID PETROLEUM PRODUCTS

The present invention relates to a method of identifying liquid petroleum products through the application of far red or near infra red fluorescence spectroscopy.

Petroleum refinery processes such as distillation are used to  
5 break down crude oil into numerous useful products which may be marketed both for industrial and for domestic use. Such products are often blends which can contain up to six various components. It is therefore important to be able to accurately identify such blends and perhaps a specific component within the blend.

10 The detection and identification of liquid hydrocarbons using chemical markers is well known. EP-A-512404 discloses a method of identifying liquid hydrocarbons by the addition of a derivative of 3, 5-dinitro-benzoic acid. Gas chromatographic separation followed by component detection using a suitable detector is used to identify  
15 the chemical marker.

Furthermore, US 4278444 discloses a method of detecting the presence of regular unleaded or super unleaded gasoline. A minor amount of an alkylated isodibenzanthrone is added to the gasoline and the presence of such is detected by running the sample on a  
20 fluorescence spectrophotometer. The results are compared with predetermined standard results.

We have now developed a method of identifying liquid petroleum products using a chemical marker which avoids both the preparation of standard data or the use of invasive analytical techniques. The  
25 present invention provides a quick, efficient and non-invasive

method of identifying liquid petroleum products.

Thus, according to the present invention there is provided a method of identifying a liquid petroleum product using a device comprising a laser source and a means for detecting a fluorescence  
5 signal said process comprising:

a) a first step of adding to the liquid petroleum product, a material capable of fluorescing in the far red or near infra red region of the spectrum,

b) a second step of exposing the liquid petroleum product  
10 obtained from said first step to the laser source at a wavelength in the far red or near infra red region of the spectrum suitable for exciting the material,

c) determining the presence of the material in the liquid petroleum product by detecting the fluorescence signal.

15 The present invention provides a method of identifying liquid petroleum products by the addition of a fluorescence marker wherein the fluorescence signal is detected.

The method of the present invention is carried out using a device which comprises a laser source, and means for detecting the  
20 fluorescence signal. It is preferred that the device is a hand-held portable unit, especially capable of operating from an internal power source.

The method of the present invention is applicable to liquid petroleum products. By liquid petroleum products is meant gasoline,  
25 aviation fuel, kerosine, paraffin, diesel fuels, lubricating oils, marine lubricants, fuel oils and used oils. The method is particularly applicable to the detection of lubricants and fuels.

The liquid petroleum product containing the material is exposed to a laser source at a wavelength in the far red or near  
30 infra red region of the spectrum. By far red and near infra red region, is meant frequencies in the range of from 600 to 3000 nm.

The method of the present invention requires the addition of a material which is capable of fluorescing in the far red or near  
35 infra red regions of the spectrum. Suitable materials include dyes and rare earth compounds which fluoresce at wavelengths in the range

of from 600 to 1000 nm, preferably from 700 to 900 nm.

Dyes suitable for use in the present invention include general commercial laser dyes, especially as defined in general formula I where X is C(dialkyl) or S, Y is C<sub>2</sub> to C<sub>7</sub> alkyl and n is 1 to 10.

5

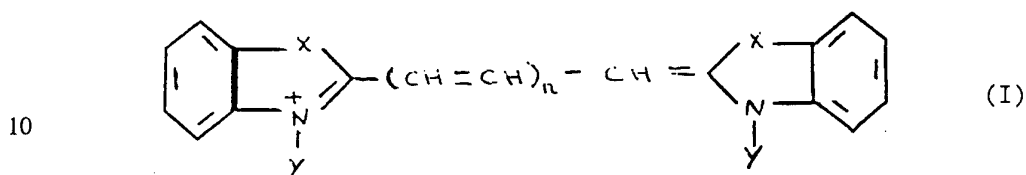

Preferably X is S, Y is C<sub>2</sub> alkyl and n is 3.

15

A dye according to general formula II may also be used in the present invention where X may be selected from C(dialkyl) or S, n may be from 1 to 10 and Y may be Et or (CH<sub>2</sub>)<sub>4</sub>SO<sub>2</sub>O<sup>-</sup>

20

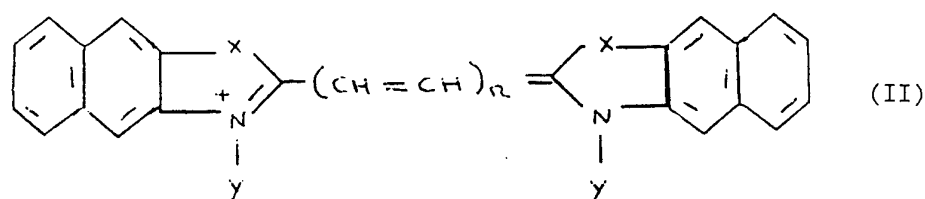

25

Preferably X is C(dimethyl), Y is (CH<sub>2</sub>)<sub>4</sub>SO<sub>2</sub>O<sup>-</sup> and n is 3.

Rare earth compounds also suitable for use in the present invention include those from the lanthanide and actinide series.

30

Especially preferred is the use of rare earth metal salts of organic surfactant species, e.g. an alkyl or aryl sulphonate.

The material may be added directly to the liquid petroleum product or may suitably be dissolved in an appropriate solvent to produce an intermediate dye concentrate. The material may be dissolved in acetone, dichloromethane, alcohols, toluene, glycols,

35

base oils, alkyl benzene and esters. The preferred solvent is a glycol such as propane-1,2-diol.

In some circumstances, it may be preferred to add two materials to the liquid petroleum product in a predetermined weight ratio. The ratio of the fluorescence intensities observed for each dye is proportional to the predetermined weight ratio and may therefore be used to identify the liquid petroleum product.

A particular advantage of the present invention is that very low concentrations of the materials are added to liquid petroleum product. Suitably, the material may be present in a concentration from 0.001 to 1 ppm.

The liquid petroleum product containing the material is exposed to a laser source at a wavelength in the far red or near infra red region of the spectrum. A suitable laser source may be a diode laser which has the advantages of low cost, small size, high reliability and direct current modulation of output which allows lock-in amplification to be used.

The fluorescence signal emitted as a result of the laser excitation may be detected by any suitable means. It is preferred to use a silicon photodetector. The presence of the signal may suitably be identified by conversion to an electric signal. The signal may be measured by a visual display unit.

It is preferred that the laser source, the silicon photodetector and the visual display component be provided in a portable unit.

A particular advantage of the present invention is that the device provides a non-invasive method of detecting liquid petroleum products. Where the container accommodating the liquid petroleum has a light transmitting window or is made from a transparent material, extraction of the product is not required.

The invention will now be described by way of example with reference to Figures 1 and 2 and the following examples.

A diode laser (1) emitting at a wavelength of 670 nm is used to illuminate a liquid petroleum product sample (2) incorporating a suitable material capable of fluorescing in the far red or near

infra red region of the spectrum. The laser is recollimated by a glass lens (3) before entering the sample. Some of the fluorescence generated along with some of the reflected and scattered laser light is also recollimated by lens (3), reflected by an aluminium coated mirror (4) positioned at 45° to the laser output and focused by means of lens (5) onto a silicon photodetector (6). A band pass filter (7) transmitting at the fluorescence wavelength is used to block the 670 nm reflected and scattered light. The photodetector output is amplified using a two-stage single chip amplifier.

In Figure 2 the fluorescence spectra from a sample incorporating two dyes are recorded by using two detectors.

The output from the laser (11) after reflection by the sample (12) as the mirror (13) is passed through lens (14) and split by the beamsplitter (15) before passing to the photodetectors (16) and (17).

#### Example 1. IDENTIFICATION OF GASOLINE PRODUCTS

A gasoline (BP Eurograde unleaded premium gasoline conforming to BS4040) containing a dye concentration of 100 ppb was prepared from a solution of 100 ppm of the following dye in propan-1,2-diol, hereinafter referred to as IR-125. IR-125 was purchased from Exiton (Laser Dyes).

25

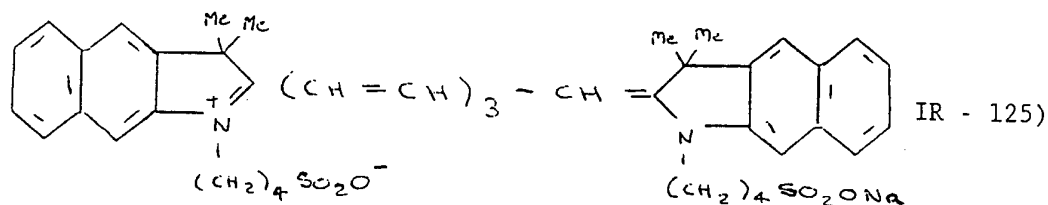

30

100 ppm of the propan-1,2-diol solution was then diluted (1 part in 1000) with the gasoline to provide a final gasoline/dye

35

solution of 1000 ppb.

The solution was subjected to laser excitation at 750 nm to provide a fluorescence maximum of 833 nm.

Additional solutions containing 200 and 400 ppb dye were prepared in a similar manner.

Table 1 provides the data obtained from various gasoline products.

#### Example 2 - IDENTIFICATION OF GASOLINE PRODUCTS

The procedure of Example 1 was repeated using a dye of the following structure. This dye was purchased from Exciton (Laser Dyes).

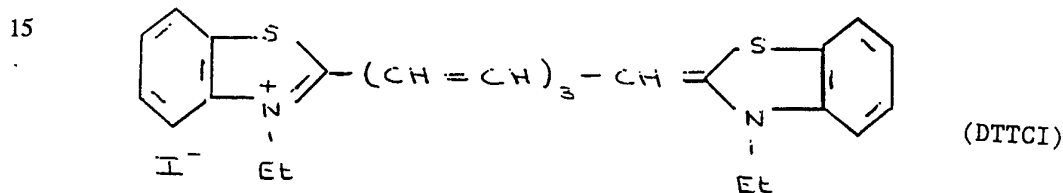

20

The dye was dissolved in xylene rather than propane-1,2-diol. Again, samples were prepared with various concentrations of the dye. Results from the fluorescence measurements are given in Table 2.

25

#### Comparative Example 1 - NON-LASER EXCITED FLUORESCENCE

Non-laser excited fluorescence spectra (200 - 900 nm) were obtained for a sample of Vanellus C3 multigrade lubricant (ex BP) with and without 40 ppb of IR -125 dye. Both the fluorescence and absorption spectra (fluorescence maxima of 833 nm and absorption maxima of 795 nm) appear identical. Therefore the dye cannot readily be detected without use of laser excited fluorescence spectroscopy.

35



Comparative Example 2 - THIN LAYER CHROMATOGRAPHY

Thin layer chromatography (TLC) was carried out on a Vistra 7000 lubricant containing 40 ppb of IR - 125 dye. The analysis was repeated on the lubricant without the dye. The TLC traces were identical for both samples even when looking for weak fluorescence spots under various wavelength light sources (218, 280, 365, 510 and 700 nm).

10

15

20

25

30

35

Table 1 - IDENTIFICATION OF GASOLINE PRODUCTS USING IR-125 DYE

CONCENTRATION OF IR-125(ppb)	READING
0	0
100	12
200	16
400	80

Table 2 - IDENTIFICATION OF GASOLINE PRODUCTS USING DTTCI

CONCENTRATION OF DTTCI (ppb)	READING
0	2
40	3
400	10

## Claims:

1. A method of identifying a liquid petroleum product using a device comprising a laser source and a means for detecting a fluorescence signal, said process comprising:
  - (a) a first step of adding to the liquid petroleum product a material capable of fluorescing in the far red or near infra red region of the spectrum;
  - (b) a second step of exposing the liquid petroleum product obtained in said first step to the laser source at a wavelength in the far red or near infra red region of the spectrum suitable for exciting the material;
  - (c) determining the presence of the material in the liquid petroleum product by detecting the fluorescence signal.
2. A method according to Claim 1 in which the device is a hand held portable unit.
3. A method according to Claim 1 or Claim 2 in which the liquid petroleum product is gasoline, aviation fuel, kerosine, paraffin, a diesel fuel, a lubricating oil, a marine lubricant, a fuel oil or a used oil.
4. A method according to any one of the preceding claims in which the material capable of fluorescing in the far red or near infra red region of the spectrum is present at a concentration of from 0.001 to 1ppm.
5. A method according to any one of the preceding claims in which the material capable of fluorescing in the far red or near infra red region of the spectrum is a dye or a rare earth

compound.

6. A method according to claim 5 in which the rare earth compound is a rare earth metal salt of an organic surfactant.

7. A method according to claim 5 in which the dye is according to general formula I where X is C(dialkyl) or S; Y is C<sub>2</sub> to C<sub>7</sub> alkyl and n is 1 to 10.

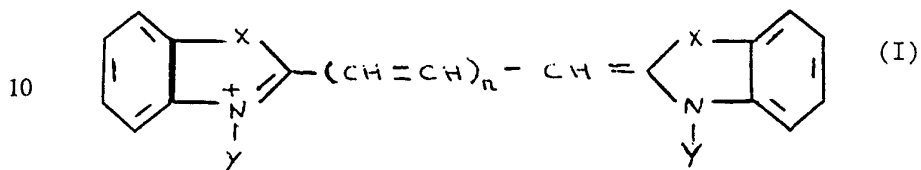

15 8. A method according to claim 7 in which X is S, Y is C<sub>2</sub> alkyl and n is 3.

9. A method according to claim 5 in which the dye is according to general formula II where X is C(dialkyl) or S, Y is Et or (CH<sub>2</sub>)<sub>4</sub>SO<sub>2</sub>O<sup>-</sup> and n is 1 to 10.

20

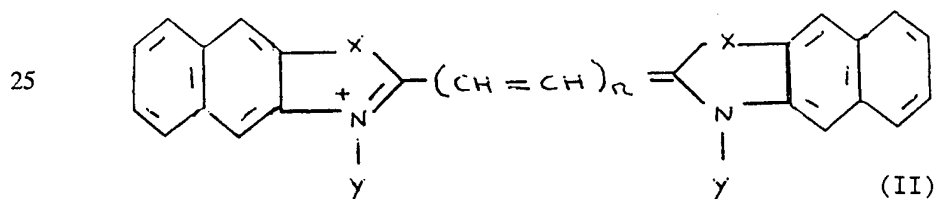

30 10. A method according to claim 9 in which X is C(dimethyl), Y is (CH<sub>2</sub>)<sub>4</sub>SO<sub>2</sub>O<sup>-</sup> and n is 3.

35

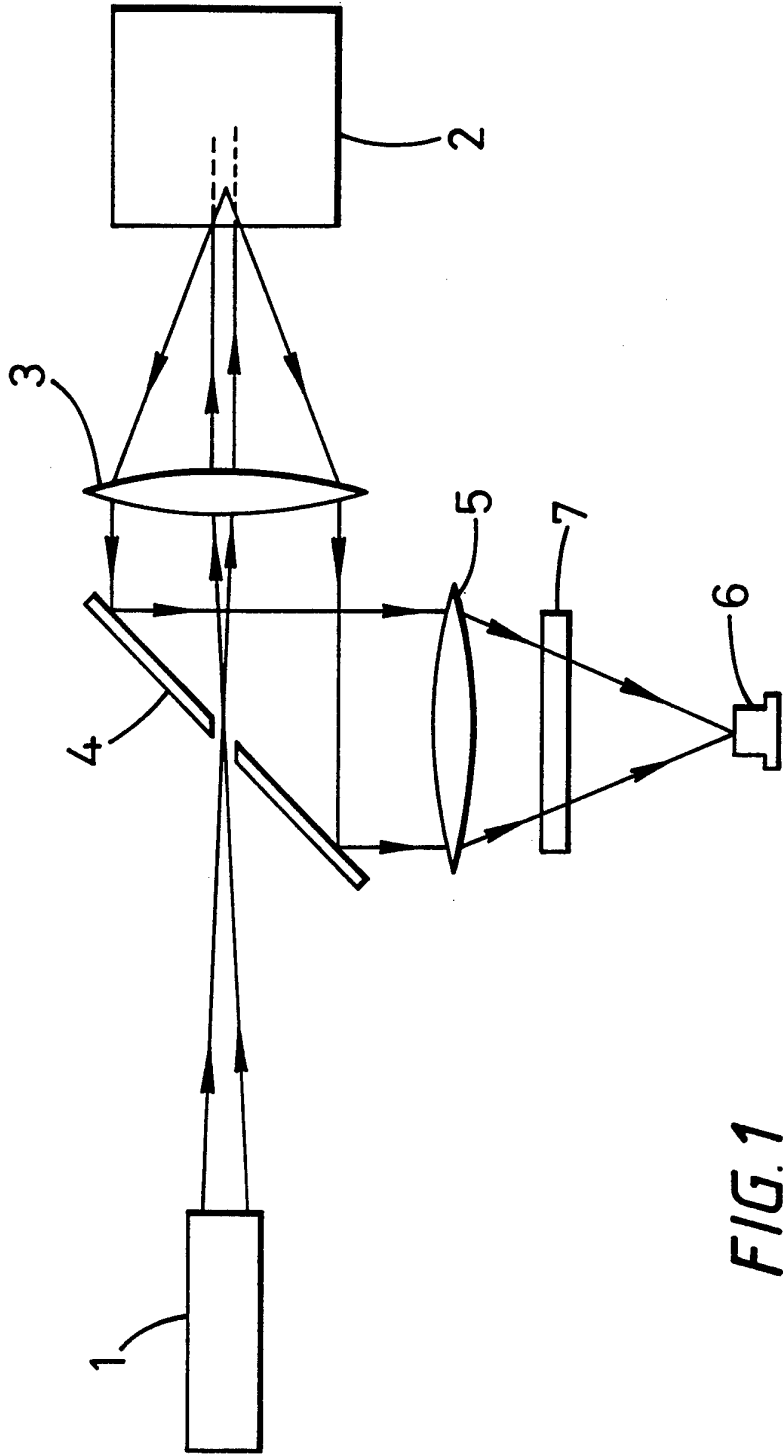

FIG. 1

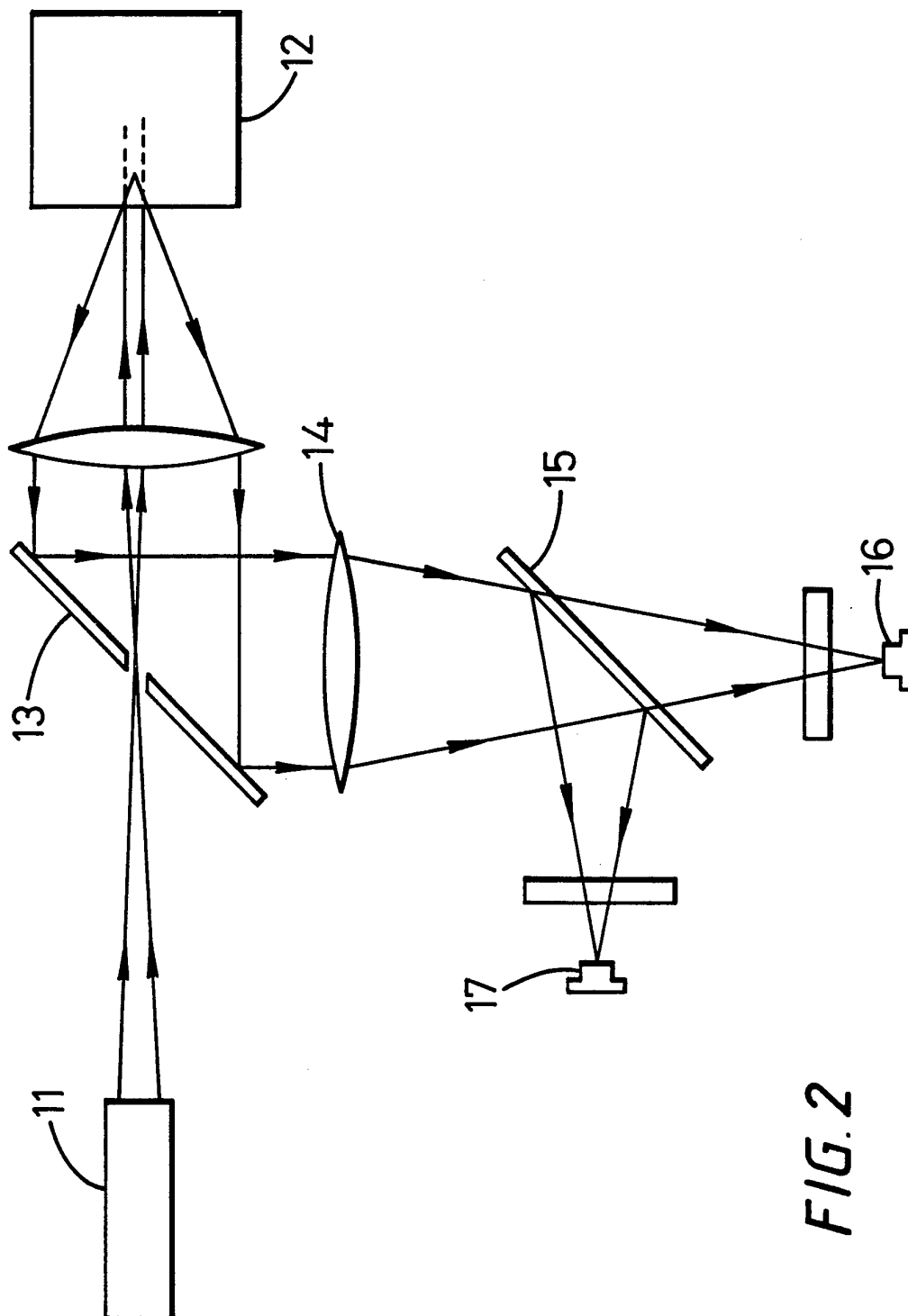

FIG. 2

## INTERNATIONAL SEARCH REPORT

International Application No

PCT/GB 93/02408

A. CLASSIFICATION OF SUBJECT MATTER  
 IPC 5 G01N33/28 G01N21/64

According to International Patent Classification (IPC) or to both national classification and IPC

## B. FIELDS SEARCHED

Minimum documentation searched (classification system followed by classification symbols)

IPC 5 G01N

Documentation searched other than minimum documentation to the extent that such documents are included in the fields searched

Electronic data base consulted during the international search (name of data base and, where practical, search terms used)

## C. DOCUMENTS CONSIDERED TO BE RELEVANT

Category °	Citation of document, with indication, where appropriate, of the relevant passages	Relevant to claim No.
Y	US,A,5 093 147 (ANDRUS) 3 March 1992 see abstract see column 2, line 18 - line 26; table ---	1,5,7-10
Y	DD,A,232 274 (VEB CHEMIKOMBINAT BITTERFELD) 22 January 1986 see abstract ---	1,5,7-10
A	US,A,4 755 469 (SHOWALTER) 5 July 1988 see abstract see column 3, line 27 - line 37 see column 4, line 35 - line 42 -----	1,3,5

Further documents are listed in the continuation of box C.

Patent family members are listed in annex.

° Special categories of cited documents :

- "A" document defining the general state of the art which is not considered to be of particular relevance
- "E" earlier document but published on or after the international filing date
- "L" document which may throw doubts on priority claim(s) or which is cited to establish the publication date of another citation or other special reason (as specified)
- "O" document referring to an oral disclosure, use, exhibition or other means
- "P" document published prior to the international filing date but later than the priority date claimed

- "T" later document published after the international filing date or priority date and not in conflict with the application but cited to understand the principle or theory underlying the invention
- "X" document of particular relevance; the claimed invention cannot be considered novel or cannot be considered to involve an inventive step when the document is taken alone
- "Y" document of particular relevance; the claimed invention cannot be considered to involve an inventive step when the document is combined with one or more other such documents, such combination being obvious to a person skilled in the art.
- "&" document member of the same patent family

Date of the actual completion of the international search

9 March 1994

Date of mailing of the international search report

16.03.94

Name and mailing address of the ISA

European Patent Office, P.B. 5818 Patentlaan 2  
 NL - 2280 HV Rijswijk  
 Tel. (+ 31-70) 340-2040, Tx. 31 651 epo nl,  
 Fax: (+ 31-70) 340-3016

Authorized officer

Thomas, R.M.

INTERNATIONAL SEARCH REPORT

information on patent family members

International Application No  
PCT/GB 93/02408

Patent document cited in search report	Publication date	Patent family member(s)	Publication date
US-A-5093147	03-03-92	CA-A- 2091163 EP-A- 0548260 JP-T- 6500590 WO-A- 9204192	13-03-92 30-06-93 20-01-94 19-03-92
----- DD-A-232274		NONE	
----- US-A-4755469	05-07-88	NONE	-----