

A. B. WILSON.  
Sewing Machine.

No. 8,296.

Patented Aug. 12, 1851.

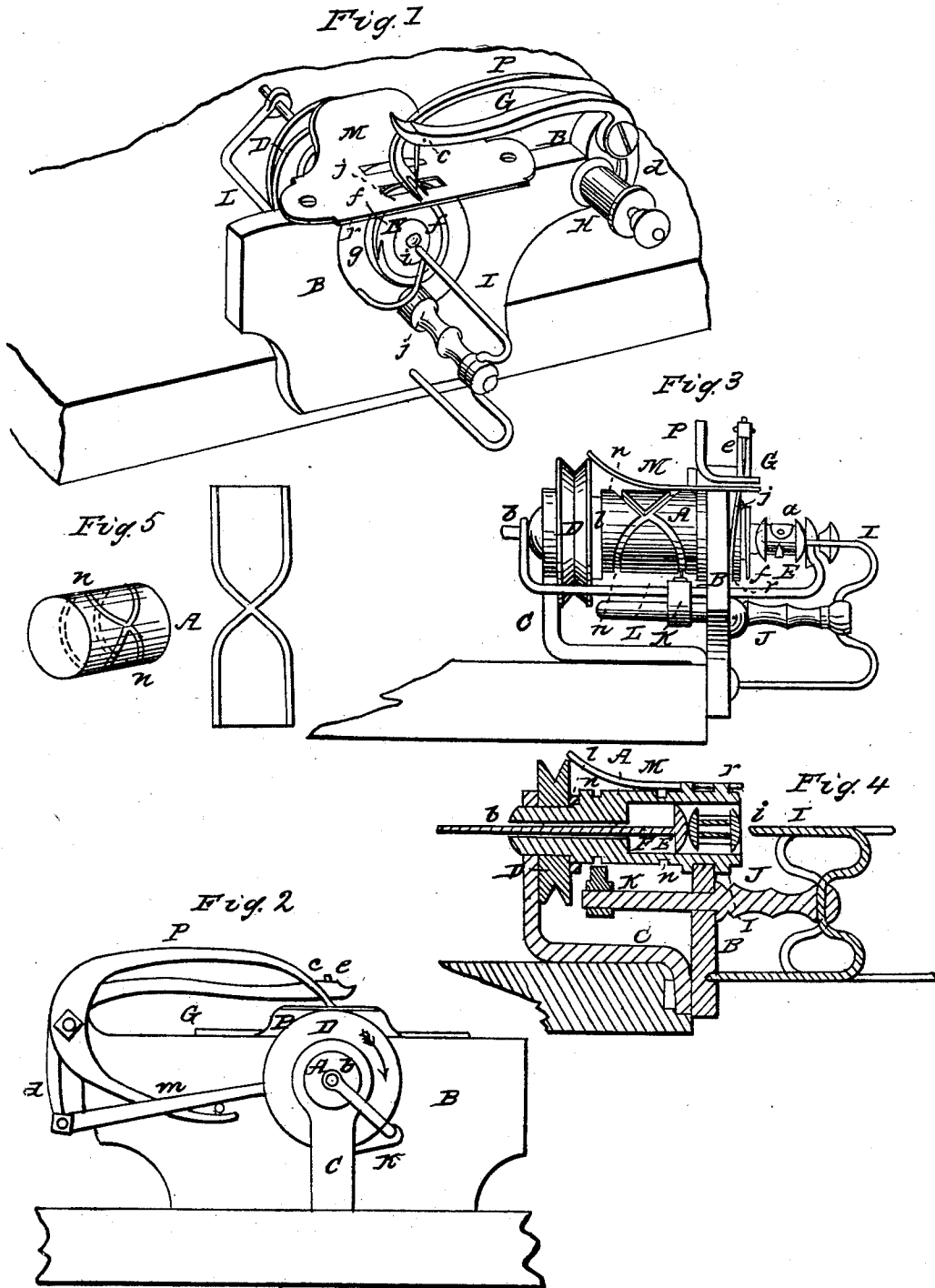

# UNITED STATES PATENT OFFICE.

ALLEN B. WILSON, OF WATERTOWN, CONNECTICUT.

## IMPROVEMENT IN SEWING-MACHINES.

Specification forming part of Letters Patent No. 8,296, dated August 12, 1851.

*To all whom it may concern:*

Be it known that I, ALLEN B. WILSON, of Watertown, in the county of Litchfield and State of Connecticut, have invented certain new and useful Improvements in Machinery for Sewing, of which the following is a full, clear, and exact description, reference being had to the accompanying drawings, which form part of this specification, and in which—

Figure 1 represents a view in perspective of my seaming-lathe. Fig. 2 is a back elevation of the same. Fig. 3 is a side elevation. Fig. 4 is a longitudinal section of the same at the center of the mandrel, and Fig. 5 represents views of the grooves of the mandrel.

The seam made by my machine is formed by the interlacing of two threads, one of which is protruded through the cloth in successive loops by means of a reciprocating needle, while the other is passed in alternately opposite directions through the loops of the first thread. The thread is supplied to the needle from a stationary bobbin, and the second thread is wound upon a traveling bobbin, which is passed in alternately opposite directions through the successive loops of the needle-thread, which are extended to a sufficient size to permit the free passage of the bobbin.

The first part of my invention consists in a method of extending the loop of thread protruded through the cloth by the needle to a sufficient size to permit the free passage of the traveling bobbin.

The second part of my invention consists in a method of tightening each stitch by the extension of the loop in forming the succeeding stitch.

The third part of my invention consists of mechanism for imparting a reciprocating movement to the traveling bobbin and for extending the loop for its passage.

The fourth part of my invention consists of a device for preventing the too rapid unwinding of thread from the bobbins.

The fifth part of my invention consists in a method of moving the cloth progressively forward, and by successive impulses, by mechanism connected with that for extending the loops and passing the bobbin; and the last part of my invention consists in a turning spring-mandrel, by means of which an empty traveling bobbin can be readily removed and its place supplied with a full one.

The several acting members of the machine as represented in the accompanying drawings are all secured to a frame which is attached to a work-table by screws. The mandrel A of the lathe is tubular. It is supported at its extremities in suitable bearings in the face-plate B and back standard, C, of the frame, and is fitted with a whirl, D, to which the driving-band is applied. Its interior is bored out to admit a bobbin, E, on which the thread is wound, and a piston, F. The bobbin has a tubular center, and is fitted with a curved spring-plate, *a*, which encircles the thread and forms a shield to prevent it from becoming slack. The piston is secured to the extremity of a piston-rod, *b*, which is passed through the smaller end of the mandrel and projects at its hinder extremity. That portion of the periphery of the mandrel nearer the whirl D is turned eccentrically, and an eccentric ring, *l*, is fitted thereto. This ring is connected by a rod, *m*, with the shorter bent arm *d* of an L-shaped lever, G, which is pivoted at the intersection of its arms to the extremity of the face-plate B. The longer arm of this lever projects in a horizontal direction from its pivot, and is perforated near its extremity to form an eye, *e*, through which the thread from a bobbin, H, is passed. This bobbin is pivoted upon a stationary spindle, and is prevented from turning too freely by a leather washer, which is inserted between the head of the bobbin and the adjacent face-plate B. The extremity of the lever G is also fitted with a needle, *e*. The latter is situated in the vertical plane passing through the axis of the tubular mandrel, and by the operation of the eccentric is caused to move up and down as the mandrel is turned. This needle is pierced near its lower extremity to form an eye through which the thread from the eye in the lever G is passed.

Immediately in front of the hollow mandrel is a stationary solid mandrel, I, whose axis is in the same straight line as the axis of the hollow mandrel, and whose extremity *i* approaches the adjacent extremity of the hollow mandrel. This stationary mandrel is formed by the upper horizontal arm of a piece of wire which is bent into a form resembling a staple, and is pivoted at its middle in the outer extremity of a horizontal arm, J. This arm is screwed into the face-plate and projects at its inner side to

form a traverse-bar, to which a traverse-block, K, is fitted. This block is secured to a shifting-rod, L, which is passed through a hole in the face-plate, and is bent upward at its hinder extremity, which is secured to the projecting extremity of the piston-rod *b*. The front extremity of the shifting-rod is also bent upward to act upon the outer head of the bobbin E, and its distance from the piston F is a little greater than the extreme length of the bobbin. A reciprocating movement is imparted to this shifting-rod by means of an endless groove, *n*, of a peculiar shape, formed in the barrel of the mandrel and acting upon a traveler, *o*, which is pivoted to the traverse-block K. This groove, if extended upon a flat surface, would be of the form represented at Fig. 5, and as the lathe-mandrel revolves the traveler is forced to traverse its whole extent in endless succession. On one half of the barrel of the mandrel the opposite extremities of the groove are parallel, so that when these portions are passing the traveler the latter remains at rest. On the other half of the barrel the extremities of the groove meet and intersect each other. Consequently when these portions are passing the traveler the latter will be alternately moved in opposite directions and will impart a corresponding movement to the shifting-rod, which in turn will move the piston alternately outward and inward in its socket in the mandrel. As the piston moves outward, it forces the bobbin before it upon the stationary mandrel, which enters its tubular center. When the movement of the shifting-rod is reversed, the piston is drawn inward in its socket, and at the same time the outer extremity of the shifting-rod, bearing against the outer head of the bobbin, draws the latter off the stationary mandrel, and causes it to enter the socket in the lathe-mandrel. From the shape of the groove on the barrel of the lathe-mandrel the bobbin is moved outward at one revolution and inward at the succeeding one, while the needle *e*, being operated by the eccentric, is depressed and raised at each revolution of the lathe-mandrel.

The outer extremity of the lathe-mandrel has a single screw-thread, *f*, formed upon its cylindrical periphery, and this screw-thread is notched to form a hook, *g*, which, as the mandrel revolves, is moved past the needle *e*, when the latter is in its lowest position. As this hook passes the needle, it engages in the loop of the thread passed through the needle-eye, and as it continues to revolve draws the loop with it. In this movement the outer half of the loop extends in a straight line across the extremity of the mandrel, while the inner half of the loop, being engaged behind the screw-thread, is retained upon the periphery of the mandrel. When the hook has accomplished about five-eighths of a revolution from the needle, the loop is of sufficient size to permit the passage of the bobbin E, which is then moved through it by the shifting-rod. From the form of the groove upon the barrel of the

mandrel this movement of the bobbin is effected while the mandrel is turning but a small fraction of a revolution, so that the bobbin is completely through the loop before the hook *g* completes its revolution. As the lathe-mandrel continues to turn, that portion of the loop which was retained upon its cylindrical periphery, being moved outward by the action of the screw-thread, slips off its vanishing extremity, and passes between the adjacent extremities of the lathe and stationary mandrels. Meanwhile the needle has been raised by the action of the eccentric, and is again depressed to carry down a loop of thread, which in its turn is extended around the mandrel to permit the bobbin to be passed through it in a direction the reverse of that it moved in in passing through the preceding loop. As the bobbin H, from which the loop-thread is supplied, is prevented from turning freely by the action of the leather washer *h*, it will not turn to give out more thread until the hook *g*, in its revolution, has drawn up all the slack thread of the preceding loop; hence the formation of each loop or stitch draws tight the preceding stitch, and this tightening is effected by the revolution of the hook in extending the loop for the passage of the bobbin.

The cloth to be sewed is applied to the plate M, the direction of the seam being parallel with the axis of the lathe-mandrel. It is held firmly upon this plate by means of a spring-guard, P, which is secured to the face-plate, and has a slot in its extremity, through which the needle passes as it is moved up and down. As the needle is moved upward, the cloth is moved outward the length of a stitch, to cause the needle to perforate it in a new place by the action of a screw-thread, *j*, formed upon a collar, *r*, on the mandrel, which projects through a slot in the plate P above.

When the machine is to be put at work, the thread on the stationary bobbin H is passed through the eye of the needle, and a driving-band is applied to the whirl D, by which the lathe-mandrel is caused to revolve rapidly in the direction indicated by the arrow in Fig. 2. The cloth is applied to the plate M, and has a continuous seam formed in it by the interlacing of the thread upon the traveling bobbin with that presented to it by the needle. When the thread upon the traveling bobbin is exhausted, the machine is stopped, the stationary mandrel is turned outward to the position in which it is represented in dotted lines in Fig. 4, the empty bobbin is removed, and a full one is substituted in its place. The stationary mandrel is now turned inward, and the lathe-mandrel is again set in motion. The extremity of the lower arm of the staple-formed wire I engages in a notch in the face-plate, and thus retains the stationary mandrel in its proper position.

The too rapid unwinding of the thread upon the traveling bobbin is prevented by the pressure of the spring-shield *q*, which thus insures the proper tightening of the stitch. A similar

shield may be applied to the stationary bobbin in place of the leather washer, before mentioned.

What I claim as my invention, and desire to secure by Letters Patent, is—

1. The combination of the rotating hook to extend the loop on one thread with a reciprocating bobbin to carry the other thread through the loop so extended, for the purpose of interlacing the two threads together, whether the parts be severally arranged and operated as herein set forth, or in any other way substantially the same.

2. The hollow mandrel, constructed substantially as herein set forth, with a groove on

its periphery to give a reciprocating motion to the bobbin, a segmental screw-thread to feed the cloth forward as the sewing progresses, and a hook and groove on its extremity to form loops on the needle-thread, in combination with a reciprocating bobbin, the whole arranged and operating substantially as herein set forth.

In testimony whereof I have hereunto subscribed my name.

ALLEN B. WILSON.

Witnesses:

E. S. RENWICK,  
CLEM. S. STEELE.