



US 20100301078A1

(19) **United States**

(12) **Patent Application Publication**
TAMIR et al.

(10) **Pub. No.: US 2010/0301078 A1**

(43) **Pub. Date: Dec. 2, 2010**

(54) **ARRANGEMENT CONVERTIBLE BETWEEN
A BACKPACK AND A CHAIR**

(22) Filed: **May 27, 2009**

Publication Classification

(75) Inventors: **Ofer TAMIR**, Voorhees, NJ (US);
Barry RONNE, Greenwood Lake,
NY (US); **Klas Fredrik PERMAN**,
Raleigh, NC (US)

(51) **Int. Cl.**
A45F 4/02 (2006.01)

(52) **U.S. Cl.** **224/155**

(57) **ABSTRACT**

Correspondence Address:
Kirschstein, Israel, Schiffmiller & Pieroni, P.C.
425 FIFTH AVENUE, 5TH FLOOR
NEW YORK, NY 10016-2223 (US)

An arrangement for converting, and a method of converting the arrangement, between a backpack and a chair, includes a bag for storing items, the bag having a back portion and an opposite front portion, a pair of shoulder straps attached to the bag for supporting the back portion against one's back during use as a backpack, and a body rest mounted on the bag for pivoting movement between a backpack position in which the body rest overlies the front portion during use as a backpack, and a chair position in which the body rest supports at least one of one's back and buttocks during use as a chair.

(73) Assignees: **Ofer TAMIR**, Voorhees, NJ (US);
Barry RONNE, Greenwood Lake,
NY (US)

(21) Appl. No.: **12/472,535**

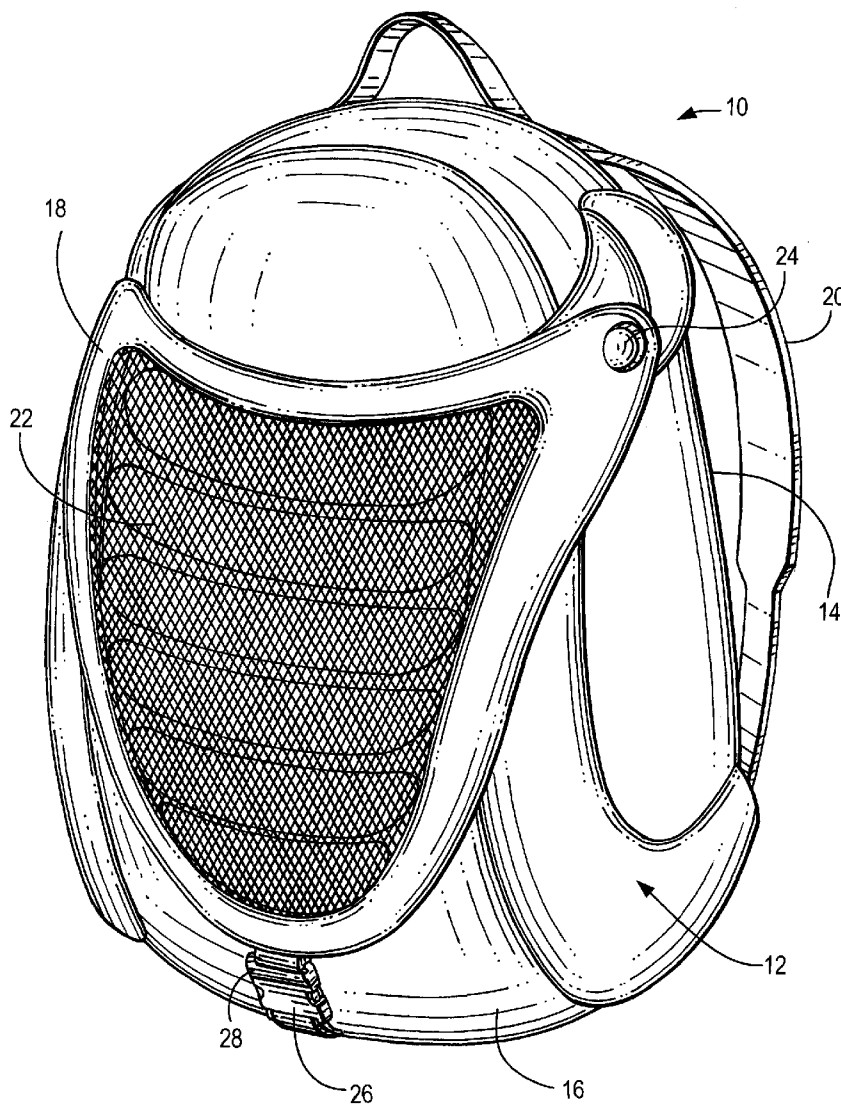
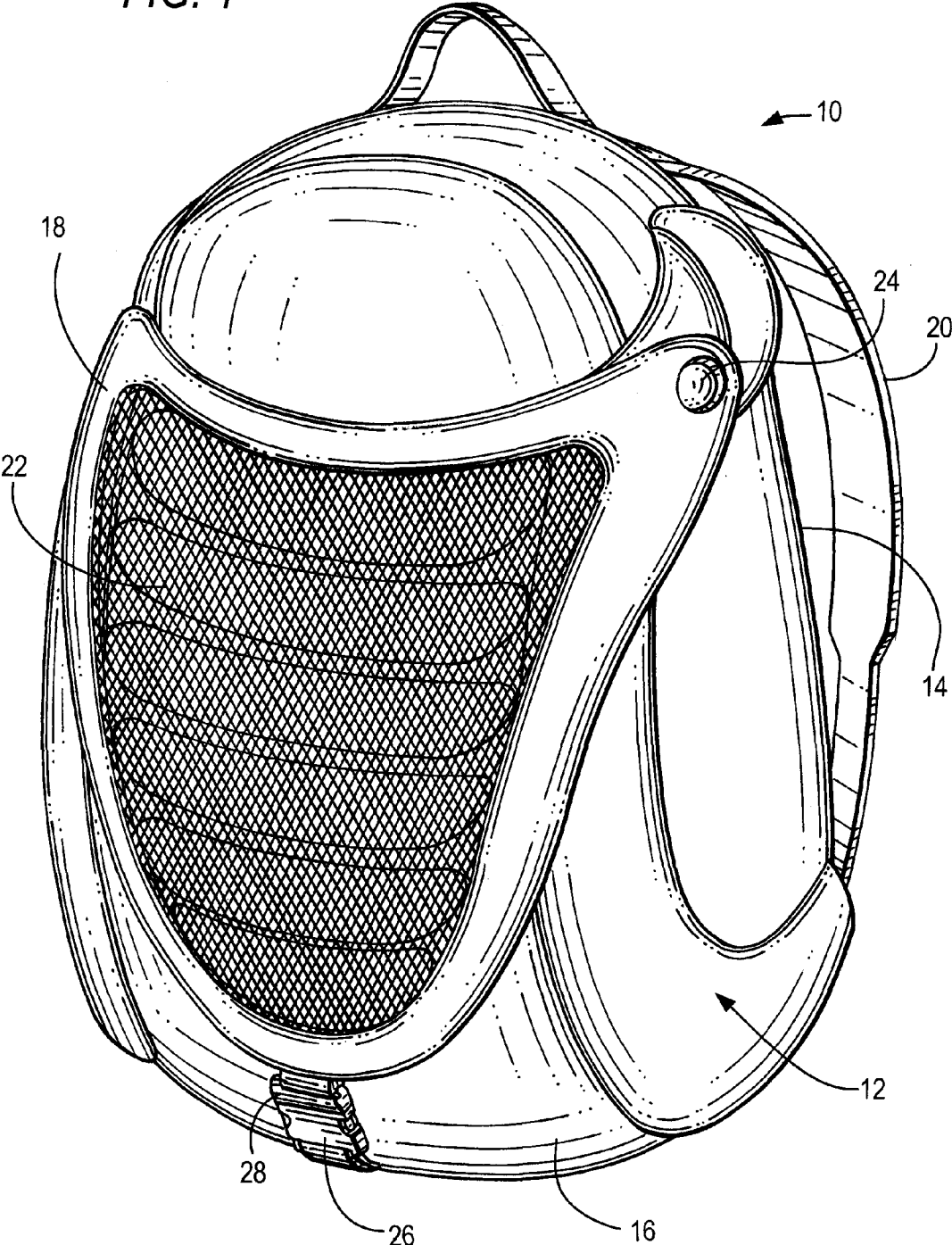
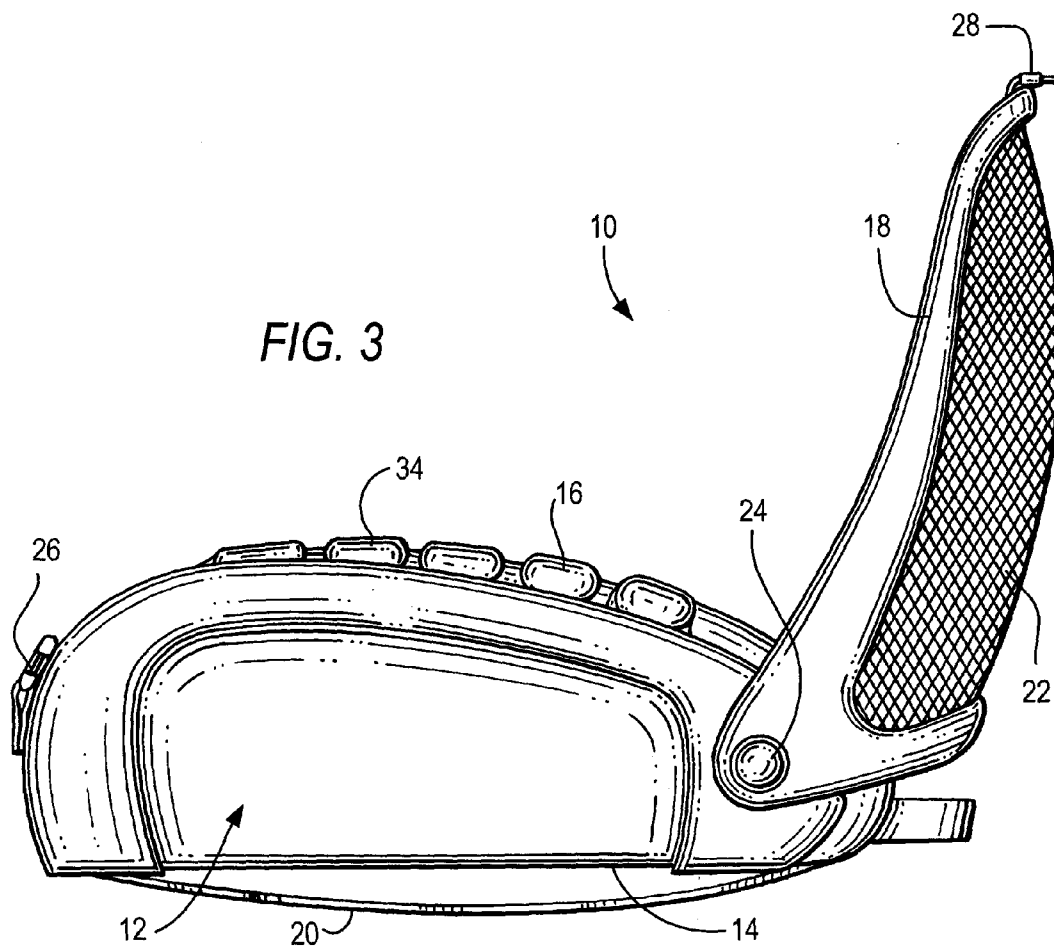
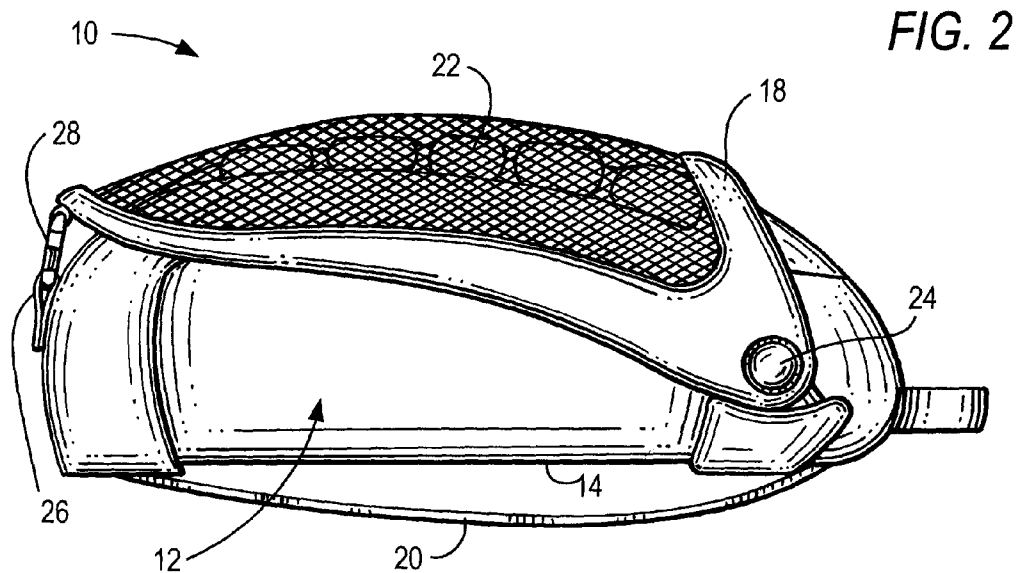

FIG. 1





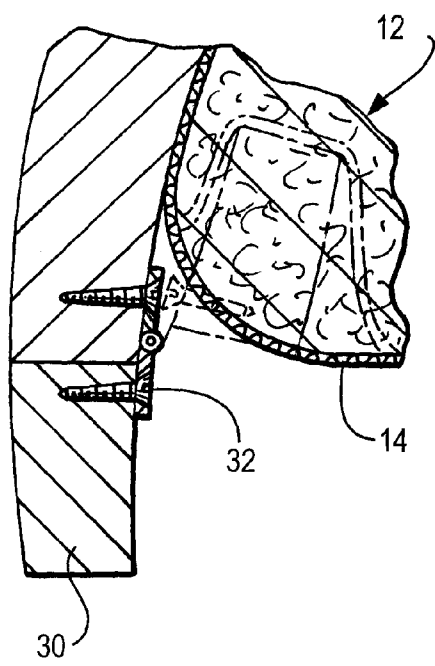

FIG. 5

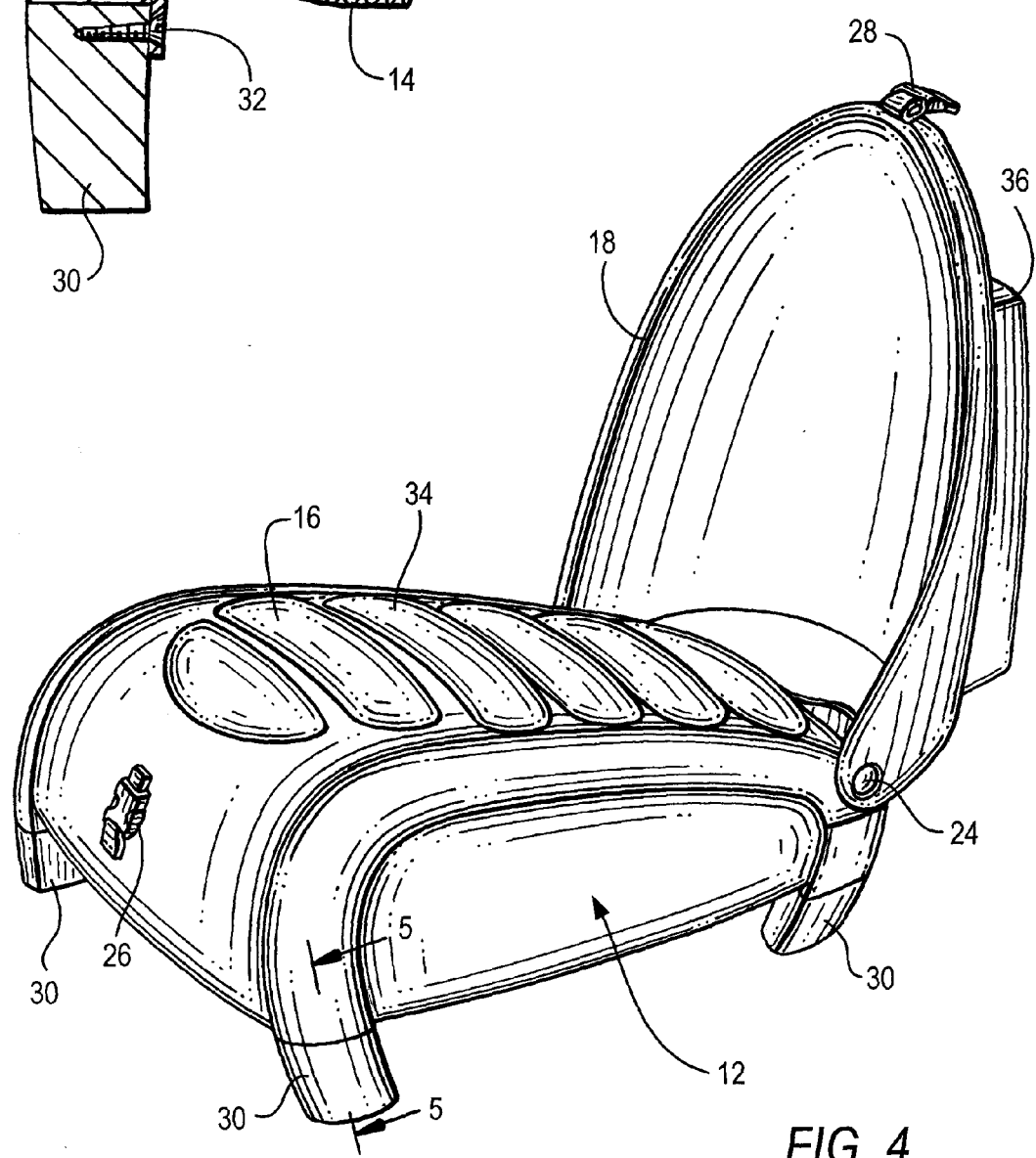

FIG. 4

FIG. 6

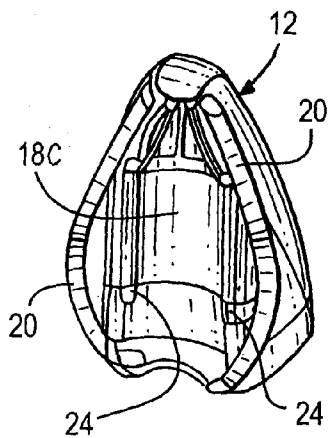

FIG. 7

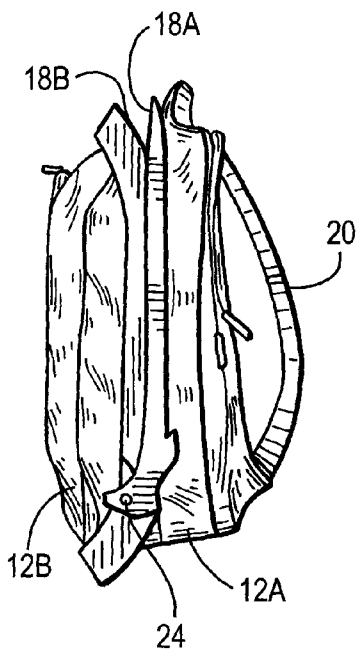
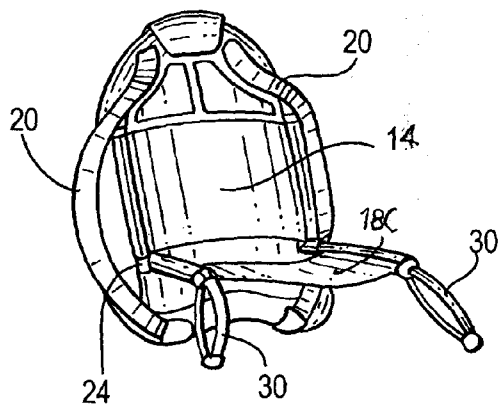

FIG. 8

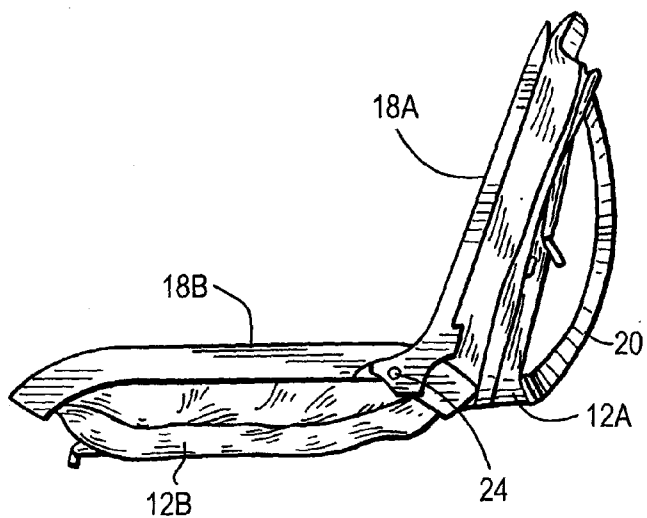

FIG. 9

**ARRANGEMENT CONVERTIBLE BETWEEN
A BACKPACK AND A CHAIR**

BACKGROUND OF THE INVENTION

[0001] This invention generally relates to an arrangement convertible between a backpack and a chair.

[0002] A backpack or rucksack is, in its simplest form, a cloth sack or bag typically carried on, and supported by, one's back and generally secured in position with one or two straps that go over one's shoulders, and is often preferred over a handbag for carrying heavy loads in one's hands for long periods of time. A padded hip belt is sometimes used to support the backpack on one's hips, leaving the shoulder straps mainly for stabilizing the load. The backpack may be frameless, or be provided with an external or internal frame. The backpack is used for the general transportation of sundry items, such as schoolbooks, recreational supplies and equipment, clothing, laptop computers, cameras, and like objects, and is sometimes simply worn as a fashion accessory, in which it performs the same function as a purse. Thus, the backpack is omnipresent in today's active society for a host of uses, both private and professional, to support both indoor and outdoor activities.

[0003] With more and more activities leading one outdoors out of the home, a chair would be desirable to take for seating purposes, but the chair is often burdensome to carry and is difficult to pack, especially in a backpack where space is limited. Sporting and concert events provide great entertainment, but the experience can be dampened if one's chair is uncomfortable, dirty or wet. Many times, there is no backed chair provided, and one has to sit on a flat bleacher seat, or even on the ground. One might bring a folding lawn chair and the like, but the lawn chair may be cumbersome to carry and may not even fit into the seat space provided. Some small collapsible chairs are good for this purpose, but they can be a nuisance to carry, especially with an armload of refreshments.

[0004] The art has proposed various arrangements of backpacks for carrying chairs, or for converting backpacks into chairs. Yet, all of these arrangements disclose complex constructions that are difficult and cumbersome to deploy and that are not stylish, because the chair constructions have multiple parts, some of which are not concealed. It would therefore be desirable to provide a stylish backpack of high fashion that does not readily reveal to others that it contains, or can be readily converted into, a chair, as well as being readily convertible from a chair to a backpack.

SUMMARY OF THE INVENTION

[0005] One aspect of this invention is directed to an arrangement convertible between a backpack and a chair, which includes a bag or pack, preferably but not necessarily made of a soft cloth material, for storing items of any sort. The bag has a back portion, preferably padded, that rests against one's back during use as a backpack, and an opposite front portion that faces away from one's back during the backpack use. A body rest is mounted on the bag for pivoting movement between a backpack position in which the body rest overlies the front portion during the backpack use, and a chair position in which the body rest supports at least a part of one's body during use as a chair. The body rest may be a backrest for supporting one's back, and/or a seatrest for supporting one's buttocks, during the chair use. A pair of shoulder straps is

preferably attached to the bag for stabilizing and supporting the bag against one's back when used as a backpack.

[0006] In a preferred construction, the body rest is a shallow curved shell or frame of rigid material, e.g., molded synthetic plastic material, or the body rest can be comprised either wholly or partly of a mesh or cloth, flexible material. A pair of spaced-apart journals is operative for mounting the body rest to the bag for enabling the pivoting movement. A latch preferably holds the body rest against, and in direct contact with, the front portion in the covering position during use as a backpack. A plurality of legs is advantageously mounted on the bag or the body rest for elevating the bag or the body rest above the ground or floor during use as a chair. Preferably, each leg is mounted for pivoting movement relative to the bag or the body rest, but other mountings, such as pop-out, pull-out or sliding mechanisms could also be used.

[0007] Another aspect of this invention is directed to a method of converting an arrangement between a backpack and a chair, and is performed by storing sundry items in a bag having a back portion and an opposite front portion; moving a body rest relative to the bag to a covering backpack position in which the body rest serves as a cover and overlies the front portion, and in which the back portion rests against one's back, during use as a backpack; and moving the body rest relative to the bag to a chair position in which the body rest serves to support at least a part of one's body during use as a chair. The body rest may be a backrest for supporting one's back, and/or a seatrest for supporting one's buttocks, during the chair use.

[0008] Thus, the arrangement is easily converted between a backpack and a chair by simply moving the body rest between the covering and chair positions. In the covering position, the body rest conceals the fact that the arrangement can be converted into a chair, thereby allowing the backpack to be stylishly configured. In the chair position, one's back and buttocks are both supported, thereby providing a comfortable sitting experience.

[0009] The novel features which are considered as characteristic of the invention are set forth in particular in the appended claims. The invention itself, however, both as to its construction and its method of operation, together with additional objects and advantages thereof, will be best understood from the following description of specific embodiments when read in connection with the accompanying drawings.

BRIEF DESCRIPTION OF THE DRAWINGS

[0010] FIG. 1 is a perspective view showing one embodiment of an arrangement convertible between a backpack and a chair in accordance with this invention;

[0011] FIG. 2 is a side elevational view of the arrangement of FIG. 1 after conversion to a backpack;

[0012] FIG. 3 is a side elevational view of the arrangement of FIG. 1 after conversion to a chair;

[0013] FIG. 4 is a perspective view showing another embodiment of an arrangement convertible between a backpack and a chair in accordance with this invention;

[0014] FIG. 5 is an enlarged sectional view taken in the direction of the arrows on the line 5-5 of FIG. 4;

[0015] FIG. 6 is a perspective view showing still another embodiment of a convertible arrangement after conversion to a backpack in accordance with this invention;

[0016] FIG. 7 is a perspective view showing the embodiment of FIG. 6 after conversion to a chair in accordance with this invention;

[0017] FIG. 8 is a side elevational view showing yet another embodiment of a convertible arrangement after conversion to a backpack in accordance with this invention; and

[0018] FIG. 9 is a side elevational view showing the embodiment of FIG. 8 after conversion to a chair in accordance with this invention.

DETAILED DESCRIPTION OF THE PREFERRED EMBODIMENTS

[0019] Referring now to the drawings, reference numeral 10 generally identifies one embodiment of an arrangement convertible between a backpack (see FIG. 1) and a chair (see FIG. 3), which includes a bag 12 or pack, preferably made of a soft cloth material, for storing items of any sort. The bag 12 could also be made of a harder, more rigid material, such as synthetic plastic. The bag 12 has a back portion 14, preferably padded, that rests against one's back during use as a backpack, and an opposite front portion 16, also preferably padded, on which one's buttock rests during use as a chair. A body rest 18 is mounted on the bag 12 for movement, preferably pivoting, between a covering backpack position (see FIG. 2) in which the body rest 18 serves as a cover that overlies the front portion 16 during the backpack use, and an upright chair position (see FIG. 3) in which the body rest 18 serves as a backrest that supports one's back during the chair use. A pair of shoulder straps 20 is preferably attached to the bag 12 for stabilizing and supporting the bag 12 against one's back when used as a backpack.

[0020] In a preferred construction, the body rest 18 is a shallow curved shell or frame entirely of a rigid material, e.g., a one-piece molded synthetic plastic material (see FIG. 4), or, as illustrated in FIGS. 1-3, a central portion of the frame can be comprised of a flexible mesh material 22, or, as illustrated in FIGS. 6-7, a central portion of the frame can be comprised of a flexible cloth material 18C. A pair of spaced-apart journals 24 is operative for mounting the body rest 18 to the bag 12 for enabling the pivoting movement. A manually-operated buckle-type latch comprised of latch portions 26, 28 preferably holds the body rest 18 against, and in direct contact with, the front portion 16 in the covering position during use as a backpack. This invention is not intended to be limited to a buckle-type latch since myriad other types of holders could be employed and, indeed, this invention also contemplates using no holder whatsoever.

[0021] In another embodiment of the convertible arrangement, as shown in FIGS. 4-5, like parts have been identified with like numerals. A plurality of legs 30 is advantageously mounted on the bag 12 for elevating the back portion 14 above the ground or floor during use as a chair. Preferably, each leg 30 is mounted for pivoting movement relative to the bag 12 by a hinge 32. This invention is not intended to be limited to pivotable legs since myriad other types of movable legs, such as telescoping, pull-out, slide-out, or pop-out legs, could be employed and, indeed, this invention also contemplates using no legs whatsoever.

[0022] In addition, in the arrangement of FIG. 4, the body rest 18 is illustrated as a one-piece shell. A storage compartment 36 is advantageously provided on the outer surface of the body rest 18 for additional storage.

[0023] In still another embodiment of the convertible arrangement, as shown in FIGS. 6-7, like parts have been identified with like numerals. Instead of the body rest serving as a backrest as in FIGS. 1-5, the body rest now serves as a seatrest 18C to support one's buttocks during chair use. A

plurality of fold-out legs 30 is advantageously mounted on the body rest for elevating the seatrest 18C above the ground or floor during use as a chair. Additional legs could be mounted on the bag 12 to elevate the entire bag 12 off the ground.

[0024] In yet another embodiment of the convertible arrangement, as shown in FIGS. 8-9, like parts have again been identified with like numerals. Instead of the body rest serving only as a backrest as in FIGS. 1-5, or only as a seatrest as in FIGS. 6-7, the body rest is comprised of two parts 18A, 18B, which are respectively attached to two bag portions 12A, 12B. The part 18A and the bag portion 12A together serve as a backrest, and the part 18B and the bag portion 12B together serve as a seatrest. Legs or a rigid frame for the bag prevent items in the bag from being squashed during use as a chair.

[0025] Thus, the arrangement is easily converted between a backpack and a chair by simply pivoting the body rest between the covering and chair positions. In the covering position, the body rest conceals the fact that the arrangement can be converted into a chair, thereby allowing the backpack to be stylishly configured. In the chair position, one's back and buttocks are both supported, thereby providing a comfortable sitting experience. Pads 34 are advantageously provided on the front portion 16, or on the parts 18A, 18B for added seating comfort.

[0026] It will be understood that each of the elements described above, or two or more together, also may find a useful application in other types of constructions differing from the types described above.

[0027] While the invention has been illustrated and described as embodied in an arrangement for, and a method of, converting the arrangement between a backpack and a chair, it is not intended to be limited to the details shown, since various modifications and structural changes may be made without departing in any way from the spirit of the present invention.

[0028] Without further analysis, the foregoing will so fully reveal the gist of the present invention that others can, by applying current knowledge, readily adapt it for various applications without omitting features that, from the standpoint of prior art, fairly constitute essential characteristics of the generic or specific aspects of this invention and, therefore, such adaptations should and are intended to be comprehended within the meaning and range of equivalence of the following claims.

[0029] What is claimed as new and desired to be protected by Letters Patent is set forth in the appended claims.

We claim:

1. A backpack convertible into a chair, comprising:
 - a bag for storing items, the bag having a back portion facing one's back when used as a backpack, and an opposite front portion; and
 - a body rest mounted on the bag for movement between a backpack position in which the body rest overlies the front portion during the backpack use, and a chair position in which the body rest supports at least a part of one's body when used as a chair.
2. The convertible backpack of claim 1, and a pair of shoulder straps attached to the bag for supporting the bag against one's back in the backpack position.
3. The convertible backpack of claim 1, wherein the body rest supports at least one of one's back and buttocks in the chair position.

4. The convertible backpack of claim 1, wherein the body rest is comprised of at least one of a rigid and a flexible material.

5. The convertible backpack of claim 1, and a journal for mounting the body rest to the bag for pivoting movement.

6. The convertible backpack of claim 1, and a holder for holding the body rest against the front portion in the backpack position during the backpack use.

7. The convertible backpack of claim 1, and a plurality of legs mounted on at least one of the bag and the body rest for elevating the back portion above ground in the chair position.

8. The convertible backpack of claim 7, wherein each leg is mounted for movement relative to the at least one of the bag and the body rest.

9. The convertible backpack of claim 1, and a storage compartment on the body rest.

10. An arrangement convertible between a backpack and a chair, comprising:

a bag for storing items, the bag having a back portion and an opposite front portion;

a pair of shoulder straps attached to the bag for supporting the back portion against one's back during use as a backpack; and

a body rest mounted on the bag for pivoting movement between a backpack position in which the body rest overlies the front portion during the backpack use, and a chair position in which the body rest supports at least a part of one's body when used as a chair.

11. The arrangement of claim 10, wherein the body rest supports at least one of one's back and buttocks in the chair position.

12. The arrangement of claim 10, wherein the body rest is comprised of at least one of a rigid and a flexible material.

13. The arrangement of claim 10, and a journal for mounting the body rest to the bag for pivoting movement.

14. The arrangement of claim 10, and a holder for holding the body rest against the front portion in the backpack position.

15. The arrangement of claim 10, and a plurality of legs mounted on at least one of the bag and the body rest for elevating the back portion above ground in the chair position.

16. The arrangement of claim 15, wherein each leg is mounted for movement relative to the at least one of the bag and the body rest.

17. The arrangement of claim 10, and a storage compartment on the body rest.

18. A method of converting an arrangement between a backpack and a chair, comprising the steps of:

storing items in a bag having a back portion and an opposite front portion;

moving a body rest on and relative to the bag to a backpack position in which the body rest overlies the front portion, and in which the back portion faces one's back, when using the arrangement as a backpack; and

moving the body rest on and relative to the bag to a chair position in which the body rest supports at least a part of one's body when using the arrangement as a chair.

19. The method of claim 18, wherein the moving steps are performed by pivoting the body rest.

20. The method of claim 18, and supporting both of one's back and buttocks in the chair position.

* * * * *