



- (51) International Patent Classification:  
*H04R 7/00* (2006.01)     *H04R 7/02* (2006.01)
- (21) International Application Number:  
PCT/EP2014/053217
- (22) International Filing Date:  
19 February 2014 (19.02.2014)
- (25) Filing Language: English
- (26) Publication Language: English
- (30) Priority Data:  
1303514.2     27 February 2013 (27.02.2013)     GB  
1309619.3     30 May 2013 (30.05.2013)     GB
- (71) Applicant: **GP ACOUSTICS (UK) LIMITED** [GB/GB];  
Eccleston Road, Tovil, Maidstone, Kent ME15 6QP (GB).
- (72) Inventors: **OCLEE-BROWN, Jack**; 73 Maidstone Road,  
Paddock Wood, Paddock Wood, Tonbridge, Kent TN12  
6AE (GB). **DODD, Mark**; 11 Dukes Park, Woodbridge,  
Woodbrige, Suffolk IP12 2DD (GB).

- (74) Agent: **MACLEAN, Martin**; DOWNING INTELLECTU-  
AL PROPERTY LLP, Oak House, Oak End Way, Gerrards  
Cross, Buckinghamshire SL9 8BR (GB).
- (81) Designated States (*unless otherwise indicated, for every  
kind of national protection available*): AE, AG, AL, AM,  
AO, AT, AU, AZ, BA, BB, BG, BH, BN, BR, BW, BY,  
BZ, CA, CH, CL, CN, CO, CR, CU, CZ, DE, DK, DM,  
DO, DZ, EC, EE, EG, ES, FI, GB, GD, GE, GH, GM, GT,  
HN, HR, HU, ID, IL, IN, IR, IS, JP, KE, KG, KN, KP, KR,  
KZ, LA, LC, LK, LR, LS, LT, LU, LY, MA, MD, ME,  
MG, MK, MN, MW, MX, MY, MZ, NA, NG, NI, NO, NZ,  
OM, PA, PE, PG, PH, PL, PT, QA, RO, RS, RU, RW, SA,  
SC, SD, SE, SG, SK, SL, SM, ST, SV, SY, TH, TJ, TM,  
TN, TR, TT, TZ, UA, UG, US, UZ, VC, VN, ZA, ZM,  
ZW.
- (84) Designated States (*unless otherwise indicated, for every  
kind of regional protection available*): ARIPO (BW, GH,  
GM, KE, LR, LS, MW, MZ, NA, RW, SD, SL, SZ, TZ,  
UG, ZM, ZW), Eurasian (AM, AZ, BY, KG, KZ, RU, TJ,  
TM), European (AL, AT, BE, BG, CH, CY, CZ, DE, DK,

[Continued on next page]

(54) Title: ELECTRO ACOUSTIC DIAPHRAGM

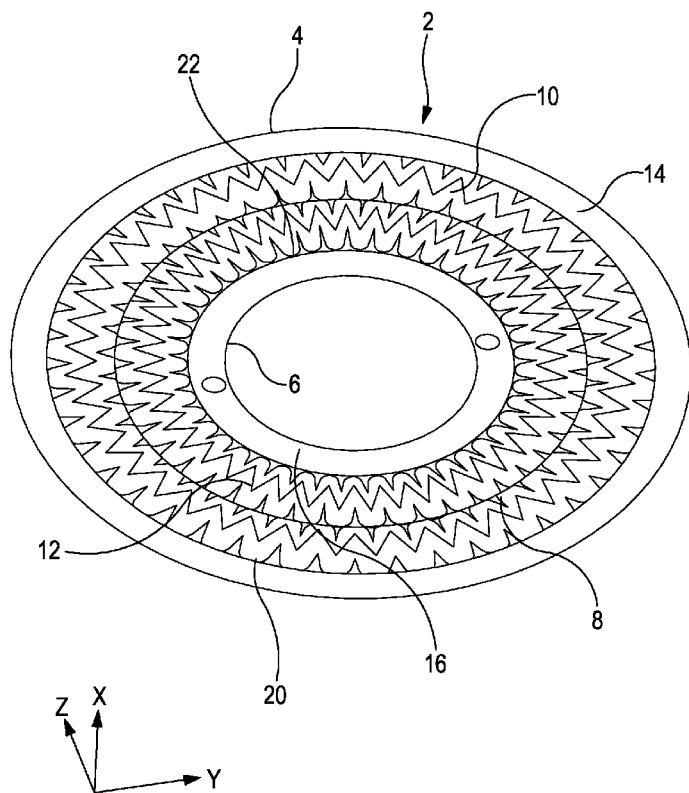

Fig. 1

(57) Abstract: A diaphragm for a loudspeaker, wherein the diaphragm is formed generally in a closed loop around a central void, the loop lying in a plane, the diaphragm having an axis in a direction orthogonal to the plane along which axis the diaphragm is arranged to be driven in use, the diaphragm having inner and outer circumferential edges which are adapted, in use, to be fixed in position, wherein a substantial portion of the diaphragm between the inner and outer edges is shaped in the direction of the said axis so as to protrude from the general plane of the diaphragm in either or both directions along the axis, and wherein said shaped portion when viewed along the direction of the axis comprises at least one series of curves extending radially across substantially all of the driven area of the diaphragm.



EE, ES, FI, FR, GB, GR, HR, HU, IE, IS, IT, LT, LU,  
LV, MC, MK, MT, NL, NO, PL, PT, RO, RS, SE, SI, SK,  
SM, TR), OAPI (BF, BJ, CF, CG, CI, CM, GA, GN, GQ,  
GW, KM, ML, MR, NE, SN, TD, TG).

— *as to the applicant's entitlement to claim the priority of  
the earlier application (Rule 4.17(iii))*

**Published:**

— *with international search report (Art. 21(3))*

**Declarations under Rule 4.17:**

- *as to the identity of the inventor (Rule 4.17(i))*
- *as to applicant's entitlement to apply for and be granted  
a patent (Rule 4.17(ii))*

## Electro-Acoustic Diaphragm

## FIELD OF THE INVENTION

The present invention relates to a diaphragm for converting electrical signals into  
5 sound, such as a diaphragm for a compression driver loudspeaker, a direct radiating  
loudspeaker in the form of a closed loop, or a concentric drive loudspeaker.

## BACKGROUND ART

In electro-acoustics there is a need for a system which simultaneously provides good  
quality high and low frequency bandwidths, whilst being relatively simple, robust, reliable  
10 and cheap. Maintaining the high frequency output of a compression driver requires a phase-  
plug closely spaced to the diaphragm to avoid an excessive acoustic compliance. The smaller  
this spacing the more extended the high frequency bandwidth will be. This phase plug to  
diaphragm spacing also limits the maximum diaphragm displacement since if the diaphragm  
contacts the phase plug gross distortion or even mechanical failure will occur. Since lower  
15 frequencies require larger volumes of air to be displaced, the smaller the phase plug spacing  
the less low frequency output is possible.

Consequently, increasing the low frequency output of a compression driver while  
simultaneously maintaining the high frequency bandwidth extension cannot be achieved by  
increasing the maximum diaphragm displacement.

20 In principle, increasing the size, and hence radiating area, of a diaphragm increases  
the low frequency output without reducing the high frequency bandwidth. However,  
practical diaphragms suffer non-piston vibrational modes at high frequencies which cause  
response irregularities and limit the usable high frequency bandwidth. Increasing the  
diaphragm size decreases the frequency of these modes thus limiting the diaphragm size  
25 possible for a particular material and geometry. Consequently, compression drivers of a  
similar size diaphragm and diaphragm material have similar limitations on acoustic output  
and bandwidth.

Conventional compression drivers with bandwidth extending to high frequencies fall  
into two main categories of diaphragm geometry. The diaphragm is either in the form of a

spherical cap, or is an annular diaphragm which typically has a V-section, as in US6804370 and US5878148.

Annular diaphragms are usually only a centimetre or so wide and thus may be fabricated from lightweight material such as mylar film. The area is not as large as a spherical cap compression driver of the same diameter but extended high frequency response may readily be obtained.

Where extended bandwidth from one source is required, a coaxial configuration of two drivers is a somewhat complicated but viable option. In this configuration one large and one small diaphragm is driven through an electrical dividing network so the high frequencies are generated by the small diaphragm and the low frequencies by the large diaphragm. The output of the two diaphragms is combined using a complicated network of acoustic paths. Since the output of one diaphragm may travel down the entrance to the other diaphragm there are a number of additional acoustic resonances which may limit sound quality and bandwidth. The diaphragms also couple: the radiation from one causes the other to move. US5878148 teaches that the use of two annular diaphragms results in a compact design with relatively short acoustic channel lengths between the diaphragms and the manifold where the acoustical outputs are combined. However, even in this instance the acoustical interactions between the diaphragms are a significant limitation to the performance of coaxial drivers. None the less, this configuration is frequently preferred to a single large spherical cap type driver due to the poor sound quality resulting from structural resonances within the diaphragm, former and surround of the latter.

#### SUMMARY OF THE INVENTION

Accordingly the present invention provides a diaphragm for a loudspeaker, wherein the diaphragm is formed generally in a closed loop around a central void, the loop lying in a plane, the diaphragm having an axis in a direction orthogonal to the plane along which axis the diaphragm is arranged to be driven in use, the diaphragm having inner and outer circumferential edges which are adapted, in use, to be fixed in position, wherein a substantial portion of the diaphragm between the inner and outer edges is shaped in the direction of the said axis so as to protrude from the general plane of the diaphragm in either or both directions along the axis, wherein said protruding shaped portion when viewed along the direction of the axis comprises at least one series of curves and wherein the curves extend either substantially uninterruptedly across the majority of the radial distance

between the inner and outer edges of the diaphragm, or across at least 90% of the radial distance between at least one of the inner and/or outer edges and a region, between the inner and outer edges of the diaphragm, which is configured for coupling to a coil for driving the diaphragm in the said direction.

5 For convenience, the present invention is principally described below with reference to a circular diaphragm in the form of a substantially planar ring with a central hole, however the invention applies equally to non-circular diaphragms, such as elliptical or race track shaped diaphragms, or any shape being symmetrical in two orthogonal directions lying in the general plane of the diaphragm and having a central hole. Accordingly, unless clearly  
10 indicated otherwise, any use in this description or in the claims of the terms "annular", "circumference", "circumferential", "circumferentially" or "around" should not be construed as being restricted to a circular shape, nor as necessarily being centred on a single axis but instead construed broadly as any substantially two-dimensional shape bounded by a closed loop. Similarly, the term "appears sinusoidal" should not be construed as limited to a strictly  
15 sinusoidal shape, but instead construed broadly as encompassing any substantially smooth series of substantially continuous and substantially cyclical, or rotationally periodic, curves.

The protruding, shaped portion may comprise a series of curves in the form of radial and circumferential modulations, which protrude axially from the general, or overall, surface of the diaphragm, and which greatly increase the geometric stiffness of the diaphragm in  
20 the axial direction while allowing circumferential stretch. Since the diaphragm is driven by an axisymmetric force there is little benefit in circumferential stiffness and it is the axial stiffness which determines the frequency of the modes. By controlling the depth, number and shape of the modulations the mode frequencies and shapes may be adjusted, in a manner which would be understood by those skilled in the art. Analysis has shown that by  
25 using sufficiently large modulations the diaphragm vibrational behaviour can be controlled to give a favourable acoustic output. This allows the use of a diaphragm with larger area, thus allowing a diaphragm providing extended high and low frequency bandwidth.

The diaphragm may comprise a surface region extending around a substantial part of the diaphragm, between the inner and outer edges of the diaphragm, and adapted and/or  
30 configured for coupling to a coil for driving the diaphragm in the direction of the axis, such as by glue or other adhesive. The surface region may extend circumferentially around the loop substantially uninterruptedly, and may be substantially axisymmetric, flat and/or substantially co-planar with the loop lying between inner and outer edges. This enables the

diaphragm to be driven around substantially all of this circumferential region, which allows the reproduction of high frequencies and inhibits vibration round the circumference of the diaphragm. Alternatively, the diaphragm could be driven via the protruding, shaped portion using a suitably shaped voice coil drive bobbin, particularly if the protrusions were small, although assembly of such a driver/diaphragm arrangement would be difficult and might necessitate driving the diaphragm over only the parts of the circumferential region projecting towards the voice coil.

The shape of the diaphragm may be defined by a series of curves which in general follow contours of constant value in the direction of the axis, or of constant protrusion from the general plane of the diaphragm.

There may be two or more series of curves extending circumferentially around the diaphragm, at least one series of curves being disposed either side of the surface region for coupling to a drive or voice coil. The or each series of curves may extend substantially uninterruptedly around substantially the whole of the diaphragm.

A substantially planar portion may extend substantially uninterruptedly around the annular diaphragm adjacent the inner edge and/or outer edge thereof. Such planar portions act as hinges, and the protruding, shaped portions in between act as rigid links, hence the linearity of the restoring force may be controlled by altering the mean shape of the diaphragm and radial modulations. The or each planar portion may blend smoothly into the or each series of curves.

The shaped portion(s), or circumferential modulations, may comprise convolutions formed in the diaphragm; these convolution shapes may be in the form of a succession of substantially continuous curves, which may have a sinusoidal appearance. Where there are two or more circumferential series of curves, these may be in radial alignment. The convolutions protrude from the general plane of the diaphragm in either or both directions along the said axis; if the protrusion is away from the driving magnet only (i.e. in the direction of acoustic waves generated by the diaphragm), this avoids any impingement on the poles of the drive coil magnet, however protrusions in both directions would be feasible if there are sufficiently numerous convolutions. Generally, the number of convolutions is not critical to the quality of the sound generated by a loudspeaker using such a diaphragm, it being understood that an increase in their number can enable a decrease in their size in the axial direction and *vice versa*. Fewer modulations of the same height would be less satisfactory vibrationally, and a very small number of very tall modulations would be a

problem since the radial stretch during manufacture would be too great; in practice, selection of the number of convolutions is likely to be a compromise between the factors of rigidity/strength, sound quality and ease of manufacture. The modulations are intended to remain substantially rigid in the axial direction in use, in order to increase axial stiffness of the diaphragm, while allowing a degree of circumferential stretch. The protrusions may be smooth, as this facilitates manufacture, or they may be smooth only where they blend in to the planar portions and otherwise present a sharp or discontinuous appearance when viewed in cross-section, as this is better acoustically.

We have found that having large areas of the diaphragm which are not shaped so as to protrude are undesirable, as such areas, even though useful as "hinges", can act as springs so that the rigid curved diaphragm acting as a mass can resonate on these. Accordingly, any unclamped planar regions at the outer and inner edges of the diaphragm, and the central surface region suitably comprise a minor part of the complete diaphragm; therefore the protruding shaped portion may comprise at least 60-70% of the radial width of the diaphragm, preferably at least 90% and more preferably 95%, and the curves (or the combined curves, where there are two or more series thereof) extend radially across substantially all of this shaped portion. To facilitate glue application and adhesion of the drive coil to the surface region, the surface region in the vicinity of the glue joint may be flat or it may be V-shaped, W-shaped or M-shaped in cross-section, however we have found that all these shapes lack radial stiffness (which is undesirable), and it is easier to eliminate or at least minimise this if the surface region is flat rather than V-shaped, W-shaped, M-shaped or any other shape.

The shape and configuration of the diaphragm is beneficial since, unlike conventional axisymmetric geometries, diaphragms in accordance with the invention do not rely on 'hoop strength' to provide the stiffness so it is possible to use non-axisymmetric geometries. For example, in another less simple manifestation the voice coil may be race track or elliptical. In this case the modulations are defined as perpendicular and tangential to the voice coil. A race track geometry is of particular use where a linear acoustic source is required. A further benefit of the new geometry is that, due to its smaller radii of curvature, it may be possible to use a thinner material while maintaining geometric stability during handling and manufacture.

Suitable materials for the diaphragm are titanium, aluminium, beryllium or plastic films such as polyether ether ketone (PEEK), polyethyleneimine (PEI), polyethylene

naphthalate (PEN), polyimide (PI) or polyethylene terephthalate (PET), particularly biaxially-oriented PET such as that sold by EI du Pont Nemours & Co under the trade mark mylar. Titanium is beneficial because it is resistant to fatigue and has a high specific modulus, similar to Aluminium. Beryllium may also be suitable although it would be extremely  
5 expensive and fatigue might be a problem. The plastic films are likely to be useful for smaller diaphragms, where the low mass/area allows higher efficiency. PEEK is advantageous because of its thermal stability and accuracy of formed components.

In another aspect, the present invention also encompasses a loudspeaker incorporating a diaphragm as described herein, and to such a loudspeaker also comprising a  
10 phase plug which is complementarily-shaped with respect to the diaphragm. If the convolutions can be made sufficiently small and numerous, it would not be necessary acoustically for the phase plug surface to follow the convolutions of the diaphragm surface.

#### BRIEF DESCRIPTION OF THE DRAWINGS

15 Embodiments of the present invention will now be described by way of example, with reference to the accompanying figures in which:

Figure 1 is a perspective view of a diaphragm in accordance with the invention;

Figure 2 is a plan view of the diaphragm of Figure 1 showing curves on the diaphragm with equal axial value;

20 Figure 3 is a cross-sectional view of the diaphragm of Figure 1, and

Figure 4 is a schematic view similar to Figure 1 but illustrating where the diaphragm may, in use, be fixed in position.

#### DETAILED DESCRIPTION OF THE EMBODIMENTS

The diaphragm 2 shown in Figure 1 lies generally in the Y-Z plane as illustrated, and  
25 is in the form of a thin ring, or annulus, with an outer circumferential edge 4 and an inner circumferential edge 6

Between the outer and inner edges is a planar circumferential portion 8 to which, in use, a drive coil (not shown) would be attached and arranged to drive the diaphragm in the X direction so as to generate acoustic waves; again, any shape or configuration would suit  
30 this portion 8 provided the drive coil can be easily attached thereto, such as V-shaped, M-shaped or W-shaped in cross-section, though in practice a substantially planar form is most

-7-

easily manufactured. This portion 8 is in the region of the glue joint fixing the diaphragm 2 to the drive coil bobbin (shown in Figure 3).

Either side of the circumferential portion 8 are a series of smooth circumferential modulations, or convolutions, formed in the thin diaphragm, so as to protrude from the general plane of the diaphragm in the X direction. Ignoring these modulations, the general, or overall, shape of the diaphragm between the outer edge 4 and the circumferential portion 8, and between the circumferential portion 8 and the inner edge 6, is substantially planar, and the circumferential portion 8 is shifted axially relative to the outer and/or inner edges 4,6 by a small amount (by about 0.1mm in the 164mm diameter diaphragm described below) to give the most linear variation of force with displacement of the diaphragm; preferably the axial shift is in the positive X direction (as shown in the drawings), although it may be beneficial in some arrangements for the shift to be in the opposite, negative X direction.. Between the outer circumferential edge 4 and the outer modulations 10, and between the inner circumferential edge 6 and the inner modulations 12 are outer and inner planar regions 14, 16; a major portion of these regions is, in use, clamped so as to fix the diaphragm in position, the remaining, minor portion of these regions, indicated at 22,20, and located adjacent the outer circumference of the outer modulations 10 and adjacent the inner circumference of the inner modulations 12 function as hinges, allowing the modulations 10, 12 to remain as substantially rigid acoustic generators when the diaphragm is driven in the X direction. The circumferential portion 8 (the area of which is also small in relation to those of the inner and outer series of curves 10, 12) may also act as a hinge.

Figure 2 shows the diaphragm 2 schematically in plan view, with the series of curves 10, 12 indicated by a number of contours L joining points equally positioned in relation to the X axis. Both the outer modulations 10 and the inner modulations 12 are shown in the form of a succession of continuous, periodic curves described circumferentially around the diaphragm at contours of axial value. Each of these series of curves, which appear sinusoidal, extends circumferentially around the diaphragm 2. As shown, the curves are in alignment, with the troughs and peaks of the inner series 12 and outer series 10 in radial alignment, however for some applications it may be preferable for the two series to be displaced so that the respective peaks and troughs are out of alignment. For some applications it may be favourable to have a different number of corrugations in the inner and outer series.

Figure 3 shows the diaphragm 2 in cross-section, with a voice coil 18 connected at the circumferential portion 8 by means of a bobbin 19 for driving the diaphragm along the X axis

Figure 4 is a schematic view, showing where in use the diaphragm 2 is clamped in position. The outer and inner planar portions 14, 16 are shown darkly shaded; it is over these shaded areas that the diaphragm 2 is clamped. Barely discernible in the drawings are very small outer and inner planar portions which are not darkly shaded, indicated generally at 20, 22; these unshaded portions are continuations of the portions 14, 16, and in use are not clamped, so that they may act as hinges, as described above. It is these unshaded portions 20, 22, together with the modulations 10, 12, which comprise the moving portion of the diaphragm. It is this moving portion of the diaphragm 2, of which at least 90% as shown is shaped so as to protrude (in this actual diaphragm 95% is modulated more than 0.05mm) and across substantially all of which moving portion the modulations extend in the radial direction – that is to say that the curves in the outer series of modulations 10 extends across substantially all of the radial distance between the outer planar portion 20 and the planar portion 8, and the curves in the inner series of modulations 12 extends across substantially all of the radial distance between the planar portion 8 and the inner planar portion 22. Given the ratio of radius to area, the curves therefore extend over at least about 97% or 98% of the radial distance between planar portions (or, in the example 5 inch (127mm) diaphragm described below, at least 99.5%). Also shown in the inner planar portion 16 are two holes 24 in the diaphragm; these allow the diaphragm to be accurately positioned rotationally before the diaphragm is clamped in position for use.

The number and depth of the modulations or convolutions are generally inversely related, that is to say that as the number of convolutions is increased their depth can be reduced, and *vice versa*, and the sound quality should be approximately equivalent. In practice there will be limits which are largely dictated by the properties of the material from which the diaphragm is made and/or the manufacturing/forming process used: if there are too many convolutions, their profile becomes too small to be accurately made, and if there are too few convolutions their depth becomes greater than the material can be stretched.

We have found that diaphragms such as that illustrated in the Figures enable a high quality acoustic output with extended bandwidths at high and low frequencies simultaneously. For example, a diaphragm which we have constructed in accordance with the principles of this invention and which performs well acoustically has a series of

sinusoidal curves, much as illustrated in the Figures, and is for use with a 5 inch (127mm) drive coil; it has an outside diameter of 164mm, a width (between the inside and outside diameter) of 38mm, a modulation height (along the X axis) of about 2mm and unclamped flat planar regions of 0.2mm width (in the radial direction) or less. Those skilled in the art will appreciate how alternatively shaped and/or sized diaphragms may be constructed in accordance with the invention.

Although not shown, it will now be understood by those skilled in the art that the illustrated diaphragm could be used with a phase plug having a complementarily-shaped and/or configured surface adjacent the diaphragm, so as to maintain a suitably small distance between the phase plug and the diaphragm when the diaphragm is at rest, so that when the diaphragm is driven the volume of air enclosed can be kept sufficiently small to avoid loss of high frequency output due to acoustic compliance but to allow the diaphragm to move with the largest displacement to achieve maximum low frequency output, and give good acoustic performance without the diaphragm impinging on the phase plug.

Typically the phase-plug to diaphragm spacing is in the region of 0.1mm – 1.2mm and the ratio of the effective diaphragm radiating area to phase-plug entrance area, also called compression ratio, is between 5 and 10. The mean flux at the voice coil is limited by the saturation of the iron poles and is between 1.2 Tesla and 2.1 Tesla depending on the magnet size and cost. The majority of conventional compression drivers use a titanium diaphragm and an aluminium voice coil, which is often copper clad to improve electrical connectivity. Preferably the height of the modulations in the diaphragm is a significant proportion of the airgap between the diaphragm and the phase plug, at least 25%.

It will of course be understood that many variations may be made to the above-described embodiment without departing from the scope of the present invention. For example, the or each series of curves could be interrupted, or only extend around parts of the circumference (though preferably any such interrupted arrangement would be symmetrical about the axis). Also, one or other of the series of curves could be omitted, or either or both could be formed in some other, essentially repetitive or rotationally periodic shape, such as one or more series of circular, elliptical, triangular or lozenge-shaped "dimples", or rows of dimples of any shape and/or of curved outline, or even pleats; the term "curves" used herein should be interpreted accordingly. It will be understood that, where the convolutions shown in the drawings are replaced by dimples, there will be a greater area between the dimples which could resonate, accordingly the proportional area of

such a dimpled diaphragm which does not protrude in the axial direction will be greater than the 5% in the illustrated embodiment, up to about 30-40%. Just as with the two curved modulations, it is preferred that dimples extend across a majority of the entire radial distance between the planar hinge portions 20, 22, or between one or both of these portions and a planar portion 8, either in a single series, or loop, of dimples, or in two or more series. It may be practicable to reduce the radial extent, in the case where there is only a single series of curves, to a bare majority, i.e. just above 50%, although in practice the smaller the area which is modulated then the less effective the geometry. Where straight and/or tangential pleats are provided, there may be substantially no axially non-protruding regions, as the pleats adjacent the clamps merge into the clamps in a "roll", as is known in the art. The curved modulations or the dimples are most easily manufactured/formed by shaping a membrane which is initially flat and/or of uniform thickness, at the same time that the diaphragm is shaped to form the shallow M shape described above; alternatively, the modulations or dimples could be formed as protrusions on (or cavities in) the surface of such a membrane, which is then shaped to form the shallow M shape. A further dome or annular driver can be provided in the hole in the centre of the diaphragm, as will be appreciated by those skilled in the art. Also, the diaphragm has been described with reference to a unitary diaphragm, all formed of the same material, however it might be suitable in some applications for different materials to be used: for example, the planar sections which act as hinges and flex in use might be made of a material which is chosen for its resistance to fatigue or to get a lower modulus of elasticity, whereas the shaped portion(s) may be of a material chosen for its high modulus. Alternatively, the diaphragm might be made in two parts and arranged to be joined appropriately, such as along the region where there is a glue joint for joining the diaphragm to the drive coil bobbin. Whilst the outer and inner regions 14, 16 are described above as planar, and are shown as lying in substantially the same plane, it should be understood that the portions of these regions closest to the outer and inner circumferential edges 4, 6 might be non-planar (so as to facilitate the clamping of the diaphragm, for example), and that the outer and inner regions 14, 16 may be shifted axially by a small amount relative to each other without significantly detracting from the performance of the diaphragm. Furthermore, where different variations or alternative arrangements are described above, it should be understood that embodiments of the invention may incorporate such variations and/or alternatives in any suitable combination.

CLAIMS

1. A diaphragm for a loudspeaker, wherein the diaphragm is formed generally in a closed loop around a central void, the loop lying in a plane, the diaphragm having an axis in a direction orthogonal to the plane along which axis the diaphragm is arranged to be driven in use, the diaphragm having inner and outer circumferential edges which are adapted, in use, to be fixed in position, wherein a substantial portion of the diaphragm between the inner and outer edges is shaped in the direction of the said axis so as to protrude from the general plane of the diaphragm in either or both directions along the axis, wherein said shaped portion when viewed along the direction of the axis comprises at least one series of curves and wherein the curves extend either substantially uninterruptedly across the majority of the radial distance between the inner and outer edges of the diaphragm, or across at least 90% of the radial distance between at least one of the inner and/or outer edges and a region, between the inner and outer edges of the diaphragm, which is configured for coupling to a coil for driving the diaphragm in the said direction.
2. A diaphragm according to Claim 1 comprising a small planar region extending radially between the radial extremities of the or each series of curves and the inner edge, outer edge and/or said region, said small planar region being, in use, unclamped.
3. A diaphragm according to Claim 1 or 2 comprising a surface region extending around a substantial part of the loop, between the inner and outer edges of the diaphragm, and configured for coupling to a coil for driving the diaphragm in the said direction.
4. A diaphragm according to Claim 3 wherein the surface region extends substantially uninterruptedly around the loop.
5. A diaphragm according to Claim 3 or 4 wherein the surface region is flat and/or substantially co-planar with the loop.
6. A diaphragm according to any of Claims 3 to 5 wherein there are two or more series of curves extending circumferentially around the diaphragm, at least one series of curves being disposed either side of the said surface region.

7. A diaphragm according to any preceding Claim wherein the or each series of curves extends substantially uninterruptedly around substantially the whole of the diaphragm.
8. A diaphragm according to any preceding claim, further comprising a substantially  
5 planar portion extending substantially uninterruptedly around the diaphragm adjacent the inner edge thereof.
9. A diaphragm according to any preceding claim, further comprising a substantially planar portion extending substantially uninterruptedly around the diaphragm adjacent the outer edge thereof.
- 10 10. A diaphragm according to Claim 8 or Claim 9 wherein the or each planar portion blends smoothly into the or each series of curves.
11. A diaphragm according to any preceding claim wherein the or each series of curves comprises curved convolutions formed in the diaphragm.
12. A diaphragm according to Claim 11 wherein the or each series of curves is  
15 substantially continuous.
13. A diaphragm according to Claim 11 or Claim 12 wherein the or each series of curves extends circumferentially around the whole of the loop.
14. A diaphragm according to any preceding Claim wherein the or each series of curves is periodic.
- 20 15. A diaphragm according to Claim 13 or Claim 14 wherein the curves are described about a closed loop on the surface of the diaphragm.
16. A diaphragm according to Claim 15 wherein the curves appear sinusoidal when viewed along the direction of the axis.
17. A diaphragm according to any preceding Claim wherein the diaphragm is generally  
25 annular.
18. A diaphragm according to any preceding Claim wherein the substantial portion comprises at least 70% of the surface area of the diaphragm.

-13-

19. A loudspeaker comprising a diaphragm according to any preceding Claim.
  20. A loudspeaker according to Claim 19, further comprising a phase plug.
  21. A loudspeaker according to Claim 20, wherein the surface of the phase plug adjacent the diaphragm is shaped and configured so as, in use, acoustically to complement the or each surface region and/or shaped portion of the diaphragm.
- 5

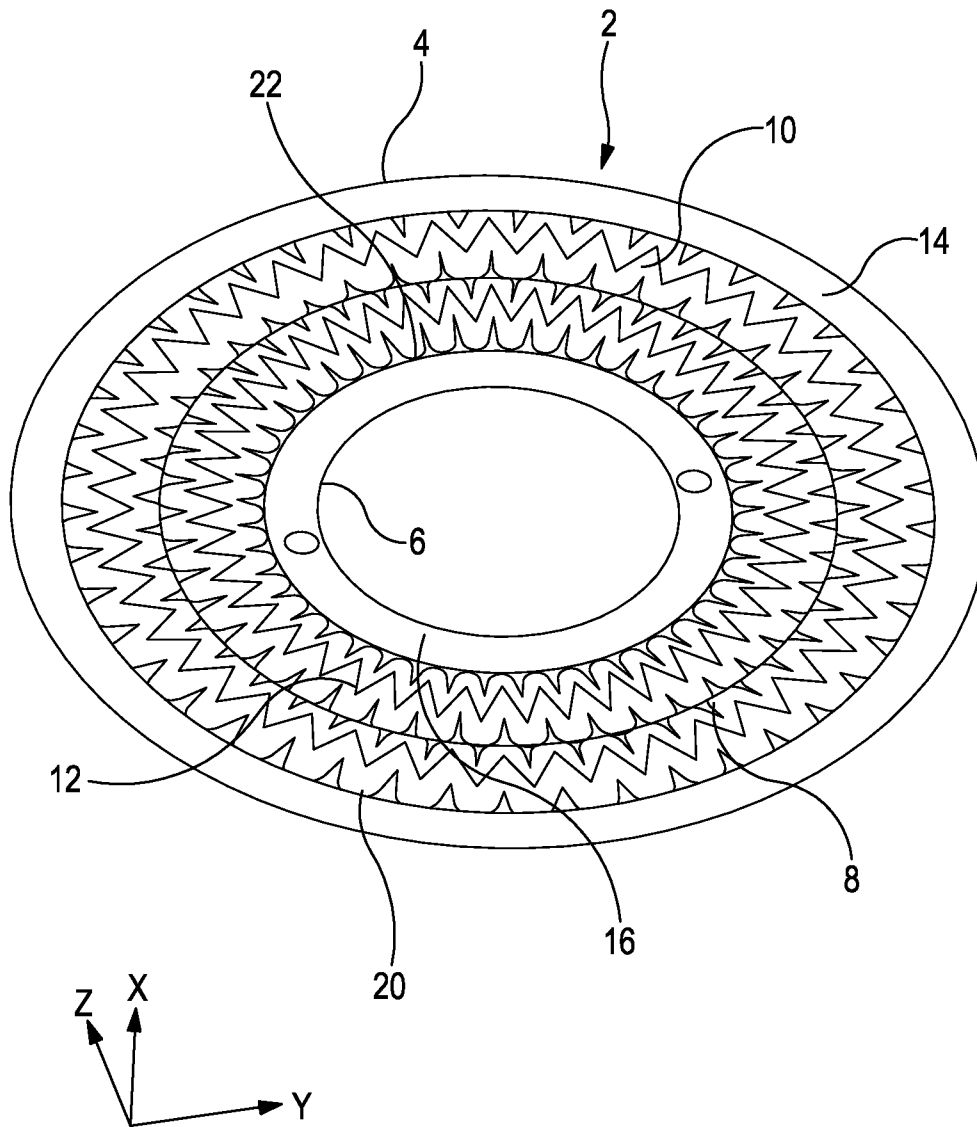

Fig. 1

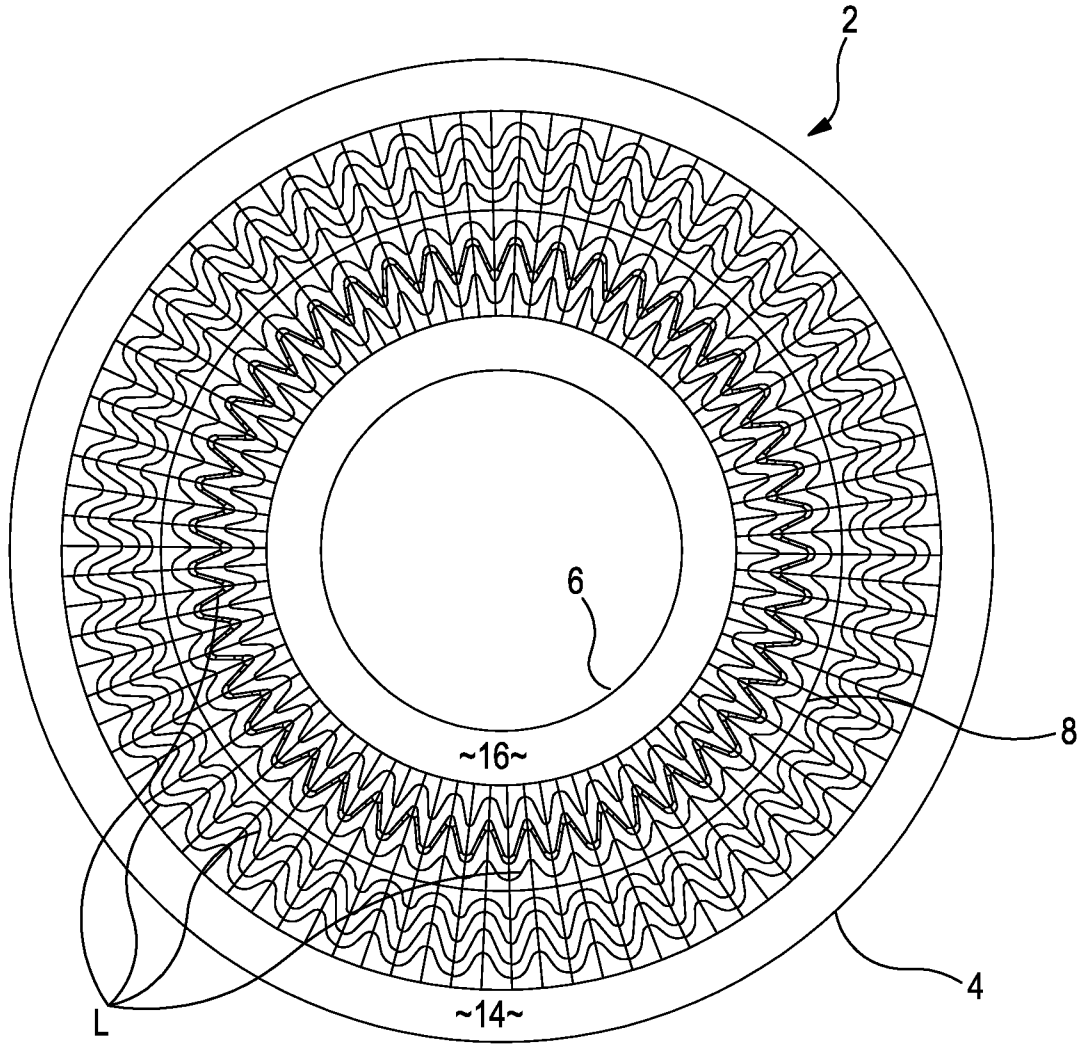

Fig. 2

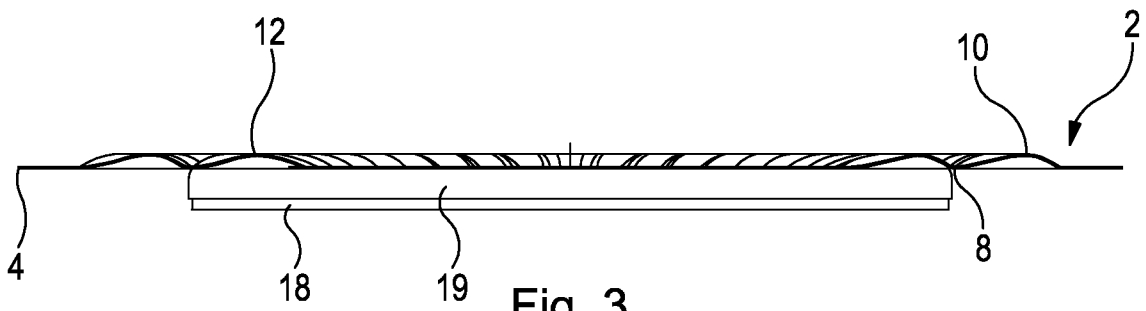

Fig. 3

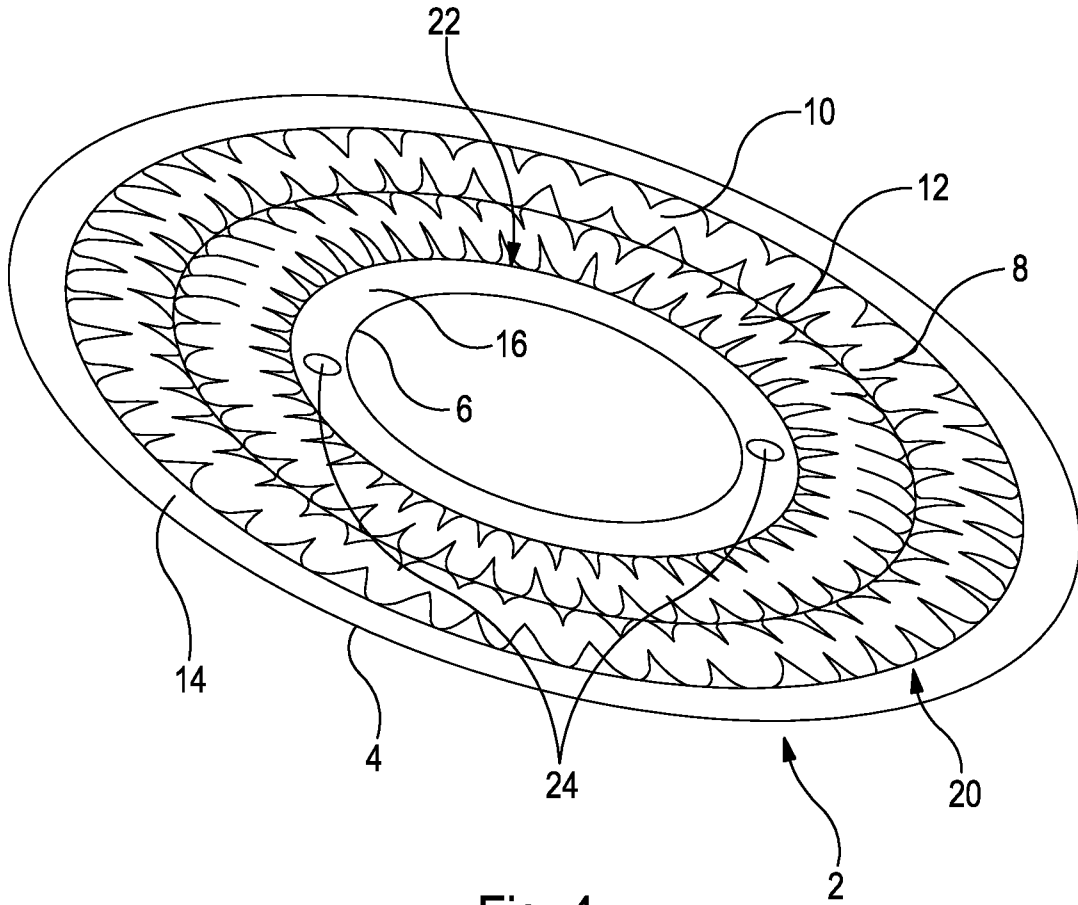

Fig. 4

**INTERNATIONAL SEARCH REPORT**

International application No  
PCT/EP2014/053217

**A. CLASSIFICATION OF SUBJECT MATTER**  
 INV. H04R7/00 H04R7/02  
 ADD.  
 According to International Patent Classification (IPC) or to both national classification and IPC

**B. FIELDS SEARCHED**  
 Minimum documentation searched (classification system followed by classification symbols)  
 H04R F16J G01L

Documentation searched other than minimum documentation to the extent that such documents are included in the fields searched

Electronic data base consulted during the international search (name of data base and, where practicable, search terms used)  
 EPO-Internal, WPI Data

**C. DOCUMENTS CONSIDERED TO BE RELEVANT**

Category*	Citation of document, with indication, where appropriate, of the relevant passages	Relevant to claim No.
X	DE 10 2007 023512 A1 (SENNHEISER ELECTRONIC [DE]) 20 November 2008 (2008-11-20) the whole document	1-21
X	WO 03/009640 A2 (KONINKL PHILIPS ELECTRONICS NV [NL]) 30 January 2003 (2003-01-30) the whole document	1-21
X	GB 2 086 586 A (SETRA SYSTEMS INC) 12 May 1982 (1982-05-12) the whole document	1-21
X	US 2005/078850 A1 (NORTON JOHN M [US]) 14 April 2005 (2005-04-14) the whole document	1-21
	----- -/--	

Further documents are listed in the continuation of Box C.

See patent family annex.

\* Special categories of cited documents :

- "A" document defining the general state of the art which is not considered to be of particular relevance
- "E" earlier application or patent but published on or after the international filing date
- "L" document which may throw doubts on priority claim(s) or which is cited to establish the publication date of another citation or other special reason (as specified)
- "O" document referring to an oral disclosure, use, exhibition or other means
- "P" document published prior to the international filing date but later than the priority date claimed

- "T" later document published after the international filing date or priority date and not in conflict with the application but cited to understand the principle or theory underlying the invention
- "X" document of particular relevance; the claimed invention cannot be considered novel or cannot be considered to involve an inventive step when the document is taken alone
- "Y" document of particular relevance; the claimed invention cannot be considered to involve an inventive step when the document is combined with one or more other such documents, such combination being obvious to a person skilled in the art
- "&" document member of the same patent family

Date of the actual completion of the international search  8 May 2014	Date of mailing of the international search report  16/05/2014
---	--

Name and mailing address of the ISA/ European Patent Office, P.B. 5818 Patentlaan 2 NL - 2280 HV Rijswijk Tel. (+31-70) 340-2040, Fax: (+31-70) 340-3016	Authorized officer  Timms, Olegs
--	--

# INTERNATIONAL SEARCH REPORT

International application No  
PCT/EP2014/053217

C(Continuation). DOCUMENTS CONSIDERED TO BE RELEVANT		
Category*	Citation of document, with indication, where appropriate, of the relevant passages	Relevant to claim No.
X	US 1 859 782 A (MAY RUSSELL P) 24 May 1932 (1932-05-24) the whole document -----	1-21

# INTERNATIONAL SEARCH REPORT

Information on patent family members

International application No

PCT/EP2014/053217

Patent document cited in search report	Publication date	Patent family member(s)	Publication date
DE 102007023512 A1	20-11-2008	-----	
WO 03009640 A2	30-01-2003	CN 1502214 A	02-06-2004
		EP 1413170 A2	28-04-2004
		JP 4121953 B2	23-07-2008
		JP 2005512353 A	28-04-2005
		US 2003112995 A1	19-06-2003
		WO 03009640 A2	30-01-2003
		-----	
GB 2086586 A	12-05-1982	DE 3142440 A1	24-06-1982
		FR 2492937 A1	30-04-1982
		GB 2086586 A	12-05-1982
		JP S5918586 B2	27-04-1984
		JP S57127161 A	07-08-1982
		US 4434203 A	28-02-1984
		-----	
US 2005078850 A1	14-04-2005	CA 2538292 A1	21-04-2005
		EP 1668955 A2	14-06-2006
		US 2005078850 A1	14-04-2005
		WO 2005036920 A2	21-04-2005
		-----	
US 1859782 A	24-05-1932	NONE	
		-----	