

T. R. BROWN.
PNEUMATIC DOOR OPERATING MECHANISM.
APPLICATION FILED MAR. 15, 1906. RENEWED MAR. 12, 1909.

1,002,028.

Patented Aug. 29, 1911.
3 SHEETS—SHEET 1.

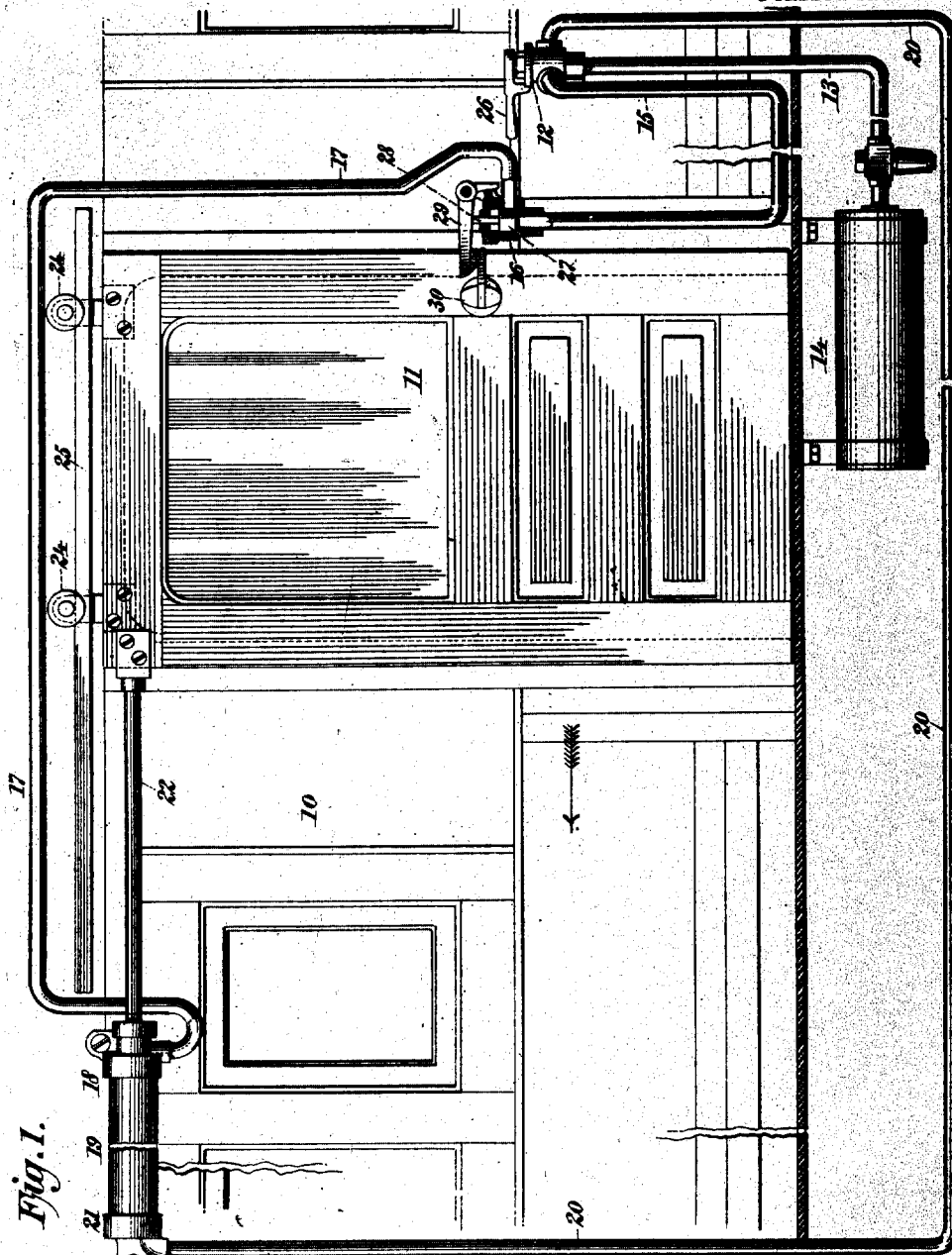

Fig. 1.

WITNESSES:

Gustav Dietrich.
Edwin H. Britton.

INVENTOR

Thomas R. Brown

BY
Chas. O. Gill
ATTORNEY

T. R. BROWN.
PNEUMATIC DOOR OPERATING MECHANISM.
APPLICATION FILED MAR. 16, 1908. RENEWED MAR. 12, 1909.

1,002,028.

Patented Aug. 29, 1911.
2 SHEETS—SHEET 1.

Fig. 2.

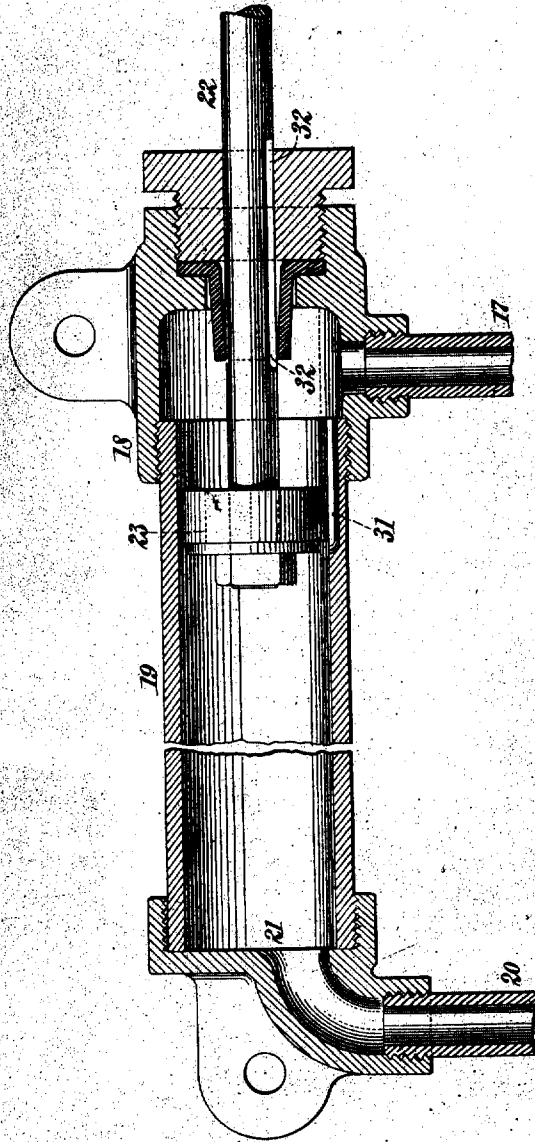

WITNESSES:
Gustave Dietrich.
Edwin H. Britton.

INVENTOR
Thomas R. Brown
BY
Chas. C. Gill
ATTORNEY

UNITED STATES PATENT OFFICE.

THOMAS R. BROWN, OF NEW YORK, N. Y., ASSIGNOR, BY MESNE ASSIGNMENTS, TO
NATIONAL PNEUMATIC COMPANY, A CORPORATION OF WEST VIRGINIA.

PNEUMATIC DOOR-OPERATING MECHANISM.

1,002,028.

Specification of Letters Patent. Patented Aug. 29, 1911.

Application filed March 15, 1906, Serial No. 306,129. Renewed March 12, 1909. Serial No. 483,060.

To all whom it may concern:

Be it known that I, THOMAS R. BROWN, a citizen of the United States, and a resident of New York city, in the county of New York and State of New York, have invented certain new and useful Improvements in Pneumatic Door-Operating Mechanisms, of which the following is a specification.

The invention relates to improvements in pneumatic door-operating mechanisms, and it consists in the novel features, arrangements and combinations of parts hereinafter described, and particularly pointed out in the claim.

I present my invention herein as applied to a car for opening and closing the door thereof, and in its preferred embodiment my invention comprises means whereby upon the movement of a control-handle to one position, compressed air will be caused to effect the unlatching and opening of the door and upon the movement of said handle to another position, the same air, then acting against a surface of larger area, will be caused to effect the closing of the door, the latter becoming latched upon reaching its closed position. I thus utilize the air by which the door is opened for closing the same and avoid the waste of air which would result if one supply of air from the reservoir were employed in opening the door and another supply thereof used for closing the door.

The mechanical devices for carrying my invention into effect may vary in many respects with the will of the manufacturer and the nature of the car or other body to be equipped with the same, but a very satisfactory embodiment of my invention will comprise a manually operable control-valve to whose casing a pipe from a reservoir for compressed air will lead, a door-latching device to which a pipe from said casing will extend and pass thence to one end of a cylinder whose piston-rod is connected with the door, and a second pipe leading from said valve-casing to the other end of said cylinder. Upon the movement of the control valve to one position the compressed air will pass through its casing to the pipe leading to the door-latching device and after freeing the latch from locking engagement with the door, travel thence to the opening end, as it may be termed, of the cylinder wherein

it will act to move the piston-rod in a direction to open the door and hold it open. Thereafter upon the movement of the control valve to another position the air supply pipe from the reservoir will be cut off and the pipe leading from the valve-casing to the other or closing end of the cylinder will be placed into communication with the pipe leading to the opening-end of said cylinder, with the result that the air in the system at one side of the piston will expand into the pipe leading to the cylinder at the other side of said piston and enter the same, wherein, acting against a surface of larger area than that in the opening-end of the cylinder, it will reverse the movement of the piston-rod and effect the closing of the door, the air in the then connected system of pipes and cylinder exhausting through a suitable vent upon the door reaching its closed position and the latch then automatically passing into locking engagement with the closed door.

The opening and closing cylinder may be located near either edge of the door as occasion may render most desirable.

The invention will be fully understood from the detailed description hereinafter presented, reference being had to the accompanying drawings, in which:

Figure 1 is a side elevation, partly broken away and partly in section, of a car equipped with door operating mechanism constructed in accordance with and embodying the invention, and Fig. 2 is a central vertical longitudinal section, partly broken away, of the operating cylinder and connected parts, the piston within the cylinder being shown in the position it occupies when the door is in closed position.

In the drawings, 10 designates a portion of a common car, 11 the door thereof, 12 the control-valve casing, 13 the supply pipe for compressed air leading thereto from a reservoir 14, 15 the pipe leading from said casing to the casing 16 for the door latching devices and extending thence by a branch pipe 17 to the opening end 18 of the cylinder 19, 20 a pipe leading from the control-valve casing 12 to the opposite or closing end, as it may be termed, 21 of said cylinder 19, and 22 a piston-rod secured at one end to the door and at the other end carrying the piston 23 within said cylinder

19. The door 11 is suspended by rollers 24 from a rail 25, upon which said rollers may travel during the opening and closing of the door.

5 The control valve within the casing 12 is operable by means of a handle 26 and is a two-way valve of any suitable character adapted when the handle 26 is turned to one position to place the supply pipe 13 in communication with the pipe 15 and when
10 turned in another or closing position to cut off the pipe 13 and place the pipes 15, 20 in communication with each other, so that the air in the pipe 15 may expand into the
15 pipe 20.

I do not limit my invention to any special form of two-way valve within the casing 12 but one example of such valve is illustrated in detail in my application, Serial
20 No. 483,058, of even date herewith for Letters Patent for improvements in door-operating mechanisms.

Within the casing 16 for the door latching devices is provided a vertical plunger
25 valve 27 from which projects a vertical stem 28 directly below the pivoted latch 29 adapted to engage a catch arm 30 secured to the door 11. When the valve 27 is in its lower position the stem 28 permits the latch 29
30 to remain in engagement with the catch arm 30, and said valve 27 when in its lower position cuts off communication from the pipe 15 to the branch pipe 17. When air is admitted to the pipe 15 for opening the door
35 it will elevate the valve 27 and disengage the latch 29 from the catch-arm 30 and also open the port to the pipe 17, into which the air will pass on its way to the opening end
40 18 of the cylinder 19. The latch 29 will remain in its elevated position so long as the air pressure remains in the pipe 15 but after the door 11 has been opened and then closed the air in the pipe system is permitted to exhaust and at such time the valve 27 will
45 descend and the latch 29 automatically re-engage the catch-arm 30.

In the operation of my invention, the door being in closed position, the control-handle 26 will be moved to place the supply
50 pipe 13 in communication with the door-opening pipe 15, and there upon the compressed air will flow through the pipe 15 to the casing 16, unlatching the door, and then through the branch pipe 17 into the
55 opening end 18 of the cylinder 19, wherein the air acting against the piston 23 will force the latter toward the other or closing-end of said cylinder and draw the door 11 to its open position. The door will be held
60 open so long as the air pressure is permitted to exert its force within the opening-end of the cylinder or against that side of the piston facing the same. When it is desired to close the door 11 the control-handle 26 will
65 be moved to its other or closed position and

thereby cut off the supply pipe 13 and place the pipes 15, 20 in communication with each other, and thereupon the air in the pipes 15, 17 and in the cylinder at the opening side
70 of the piston, will expand into the pipe 20 and pass thence into the closing end 21 of the cylinder 19, wherein said air acting against the piston 23 will drive the latter to its initial position shown in Fig. 2 and
75 effect the closing of the door. Upon the door reaching its closed position a by-pass groove 31 in the wall of the cylinder, at the opening end thereof, becomes partly uncovered and permits the air within the
80 cylinder and connected pipes to exhaust around the piston and through a vent groove 32 formed in the piston rod 22, whereupon the air pressure being relieved the valve 27 will descend to its initial position and permit the latch 29 to pass into
85 reengagement with the catch arm 30, locking the door in its closed position. The vent 32 should be so relatively proportioned and restricted in area as to permit the compressed air to escape therethrough comparatively slowly so that when the pressure
90 medium is initially supplied to the opening end of the cylinder such medium will act upon the face of the piston 23 and move the piston a distance sufficient to cut off the exhaust of the pressure medium through
95 vent groove 32 before escape of such medium therethrough to any material or appreciable extent.

The surface area of the piston against
100 which the air acts to effect the opening of the door is less than the surface area against which the air acts in forcing the door to its closed position, and thus I am enabled to utilize the same air which effected the opening
105 of the door, for closing the same. The difference in the areas exposed to the action of the air at opposite faces of the piston 23 is due to the fact that the piston-rod 22 occupies a portion of the opening end of
110 the cylinder and cuts off a portion of one face of the piston.

What I claim as my invention and desire to secure by Letters-Patent, is:—

In combination, in a mechanism for moving doors or other devices, an element to be moved, a stationary cylinder, a piston therein, a piston rod connected to the piston and to the element to be moved, to move the
115 latter, said rod being connected to one side of the piston whereby the piston has a less effective area on one side than on the other, a manually operable control valve connected with a source of supply of compressed air, pipes leading therefrom to the
120 respective ends of the cylinder, said valve, when moved to one position operating to admit the air to one of said pipes for moving the movable member in one direction, and, when moved to another position, to cut
125 13

off the air supply and place said pipes in communication with each other, whereby the air previously used at one end of the cylinder is permitted to expand into the other end of the cylinder and utilized to move the movable member in the other direction, substantially as set forth.

Signed at New York city, in the county of New York, and State of New York, this 13th day of March A. D. 1906.

THOMAS R. BROWN.

Witnesses:

ARTHUR MARION,
CHAS. C. GILL.