



- (51) International Patent Classification: Not classified
- (21) International Application Number: PCT/IB2013/061203
- (22) International Filing Date: 20 December 2013 (20.12.2013)
- (25) Filing Language: Italian
- (26) Publication Language: English
- (30) Priority Data: TO2012A001136 21 December 2012 (21.12.2012) IT
- (71) Applicant: **INDESIT COMPANY S.P.A.** [IT/IT]; Viale Aristide Merloni 47, I-60044 Fabriano (AN) (IT).
- (72) Inventors: **GAMBARDELLA, Fabio**; Viale Crotona 143/b, I-88100 Catanzaro Lido (CZ) (IT). **SCOPONI, Matteo**; Via Fogazzaro 9, I-62012 Civitanova Marche (MC) (IT).
- (74) Agents: **CAMOLESE, Marco** et al.; c/o Metroconsult S.r.l., Via Sestriere 100, I-10060 None (TO) (IT).
- (81) Designated States (unless otherwise indicated, for every kind of national protection available): AE, AG, AL, AM,

AO, AT, AU, AZ, BA, BB, BG, BH, BN, BR, BW, BY, BZ, CA, CH, CL, CN, CO, CR, CU, CZ, DE, DK, DM, DO, DZ, EC, EE, EG, ES, FI, GB, GD, GE, GH, GM, GT, HN, HR, HU, ID, IL, IN, IR, IS, JP, KE, KG, KN, KP, KR, KZ, LA, LC, LK, LR, LS, LT, LU, LY, MA, MD, ME, MG, MK, MN, MW, MX, MY, MZ, NA, NG, NI, NO, NZ, OM, PA, PE, PG, PH, PL, PT, QA, RO, RS, RU, RW, SA, SC, SD, SE, SG, SK, SL, SM, ST, SV, SY, TH, TJ, TM, TN, TR, TT, TZ, UA, UG, US, UZ, VC, VN, ZA, ZM, ZW.

(84) Designated States (unless otherwise indicated, for every kind of regional protection available): ARIPO (BW, GH, GM, KE, LR, LS, MW, MZ, NA, RW, SD, SL, SZ, TZ, UG, ZM, ZW), Eurasian (AM, AZ, BY, KG, KZ, RU, TJ, TM), European (AL, AT, BE, BG, CH, CY, CZ, DE, DK, EE, ES, FI, FR, GB, GR, HR, HU, IE, IS, IT, LT, LU, LV, MC, MK, MT, NL, NO, PL, PT, RO, RS, SE, SI, SK, SM, TR), OAPI (BF, BJ, CF, CG, CL, CM, GA, GN, GQ, GW, KM, ML, MR, NE, SN, TD, TG).

**Published:**

— without international search report and to be republished upon receipt of that report (Rule 48.2(g))

(54) Title: OVEN COMPRISING A MUFFLE ON WHICH PANELS ARE MOUNTED SOME PANELS

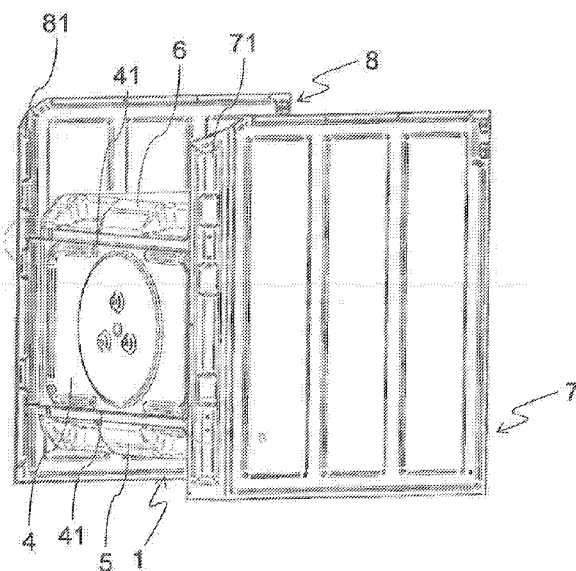

Fig. 4

(57) Abstract: The invention relates to an oven comprising a muffle (1) with an external structure, in which the side panels (7,8) are fastened to a flange (41) protruding from the muffle (1). Advantageously, the flange is located on the upper (6) or the bottom wall (5) of the muffle and, at the corners, presents the folds (42) which facilitate the fixing of the folded edges to the side panels. In this way the panels are fastened directly to the muffle, avoiding fixing parts such as brackets and the like.



## **OVEN COMPRISING A MUFFLE ON WHICH PANELS ARE MOUNTED SOME PANELS**

### **DESCRIPTION**

The present invention refers to a cooking oven with a muffle.

As known, the structure of a muffle (M) oven for cooking food comprises a substantially cubic or otherwise parallelepiped shaped body or alike, wherein is defined the cavity for cooking food frontally closed by a door, this last being usually hinged to the muffle with vertical or horizontal axis depending on the various solutions.

Around the muffle M is then applied the insulating material to isolate it thermally and all other components that complete the oven, namely the conduits of the gas and / or electrical wirings, the ventilation fan (when provided), commands, various circuits and so on.

The oven's structure is then externally closed with external panels on side, on top, on bottom and on rear; fixing of these panels have not to interfere with the insulating material and with the other above mentioned components of the oven: therefore, it is currently known to utilize a bracket support S, which is then coupled to the side panels. These side panels perform in addition of the said closure function also the structural function to keep the muffle raised between them.

The support bracket S is typically fixed to the rear wall of the muffle M through fixing screws. This kind of fixing has the drawback to concentrate in the area around the holes of the muffle M the weight of the muffle and the stresses that come from this (for example when the oven is moved). Therefore, the muffle M must be sufficiently robust so that will not be damaged. A way to avoid this drawback consists in the implementation of a muffle M using a material of greater strength and /or a metal sheet of greater thickness than the one utilized in an oven solely composed of a muffle. In this way, however, the weight and/or the cost of the muffle M are increased.

It is an object of the present invention to solve these drawbacks; in other words, it provides an oven with operating and structural characteristics such as to allow to fix the external panels without use of brackets or other similar elements, which make

inevitably more heavy the oven structure and make more problematic the assembly operations.

The basic idea of the present invention is to provide an oven in which the side panels of the structure are fixed directly to the muffle, in order to make unnecessary the bracket or other similar objects.

The present invention's characteristics are specific object of the attached claims.

These features and further advantages of the present invention will become more clear from the description of an embodiment shown in the appended drawings, provided for purely exemplary and not limiting purpose, in which:

fig. 1 illustrates a perspective view of an oven muffle according to the prior art;

fig. 2 illustrates a front view of a muffle according to the invention;

fig. 3 illustrates a top view of the muffle of Fig. 2;

fig. 4 illustrates a rear perspective view of the muffle shown in Figures 2 and 3;

fig. 5 illustrates a view of detail A of Fig. 4;

fig. 6 illustrates a view of detail B of Fig. 4.

With reference to Figs. 2, 3 and 4, an oven, according to the invention, comprises a muffle 1 in which a cavity, or cooking chamber, is delimited by a pair of side walls 2,3, a rear wall 4, a bottom wall 5 and a top wall 6.

The walls can be realized according to any known way in the art, for example a piece molded, bended or other worked metal sheet.

However, according with a preferred embodiment, the side walls 2, 3 and the rear 4 are in one piece, whereas the bottom 5 and the top wall 6 are fastened with the walls 2,3,4 by constraint means (i.e.: welds, rivets, etc.).

The oven also includes a pair of padding panels 7,8 which are positioned at the sides of the muffle 1, in order to advantageously allow the application of the insulating material around the muffle 1.

The side panels 7 and 8 are fixed to the muffle 1 through fastening means, better below described.

The upper wall 6 comprises a peripheral flange 41 which extends along its rear edge, and preferably also along the side ones; the flange 41 protrudes with respect to the rear wall 4 and, in correspondence of the rear corners, presents some folds 42 folded like an "L" .

Each one of the external panels 7, 8 has an inward folded rear edge, 71 and 81, so to advantageously facilitate the coupling between said panels 7, 8 and folds 42 of the top wall 6. Furthermore, the folded rear edge 71, 81 of the panels 7, 8 presents some deep-drawings that increase advantageously the rigidity.

As better seen in Figures 5 and 6, each folded edge 71, 81 of the panels 7, 8 comprises holes 73, 83 that allow the coupling of the respective lateral panel 7,8 with the muffle 1.

Consequently, in order to make efficient the coupling between the side panels 7,8 and the muffle 1, the flange 41 comprises at least two folds 42, positioned in the near of the ends of the rear wall 4.

Each fold 42 has folded form preferably as a "L" and includes at least one hole 43 which is aligned with the hole 73, 83 when the side panel 7,8 is coupled with the muffle 1, in order to allow the use of the fixing means, such as screws, bolts, rivets or other, to fasten stably the coupling between the panel 7,8 and the muffle 1.

Of course It is possible for the skilled person, to choose the fastening means best suited to satisfy the requirements of the application.

Several variations are obviously possible to the example until now described.

In the first instance it should be noted, that what exposed above, in relation to the upper wall 6, can also be extended to the lower wall 5; it follows, therefore, that it may be possible to have ovens in which the folds 42 are present on respective peripheral flanges 41 associated with both walls: top 6 and bottom 5, or ovens in which only the lower wall 5 is equipped with such features.

Other possible variations, hereinafter, for sake of brevity, will be highlighted only the parts different from this and subsequent variations with respect to the main embodiment above described.

A first variation (not illustrated in the attached figures) comprises some folded folds positioned on the side walls 2 and 3 of the muffle 1, wherein said folds are coupled on the side panels 7,8.

A second variation (not illustrated in the attached figures) comprises some side panels, in which each of them comprises a further folded edge, positioned in the front part of said panel, which is coupled with a reinforcement rib positioned in the front part of the muffle 1, in order to increase its stability.

In the end, a third variation comprises a reinforcing flange that runs along the edge of the lower wall, so as in the upper wall, so that the side panels may advantageously be coupled with the reinforcement wall preferably along their entire depth, in order to better even up the load on the panel.

There are, obviously, further possible additional variations to the so far described example, that fall, however, within the scope of the following claims.

**CLAIMS**

1. Oven for cooking food, comprising:
  - a muffle (1) wherein there is provided a cooking chamber surrounded by a plurality of walls (2-6) (6),
  - a pair of side panels (7,8) applied outside the muffle (1).

**characterized in that**

the muffle (1) comprises at least one pair of folds(42) projecting outside thereof, to which the side panels (7,8) are fastened.

2. Oven according to claim 1, wherein the muffle has a substantially parallelepiped shape and said at least one pair of folds (42) extends from one of the walls, in connection with the corners of the muffle.

3. Oven according to claims 1 or 2, wherein said at least one pair of folds extends from a flange(41) projecting along the edge of a wall (6)of the muffle.

4. Oven according to claim 3, wherein said side panels (7,8)comprise each a folded edge(71,81)with which a respective part of said projecting pair of folds (42) engage for fastening the panel to the muffle.

5. Oven according to claim 4, wherein said respective part of said pair of folds(42) comprises at least one first hole (43), and wherein said side panels (7,8) comprise respective second holes (73,83), and where the fastening of said side panels (7,8) to the muffle (1) occurs by fastening means that engage respective first(43) and second holes (73,83)when they are aligned with each other.

6. Oven according to any of the preceding claims, wherein said pair of folds (42) is arranged on an upper wall (6) and/orlower wall (5) of the muffle (1).

7. Oven according to claim 6, wherein the upper wall (6) of the muffle has a folded edge connected to the rear wall (4) at which the flange(41) extends.

Prior Art

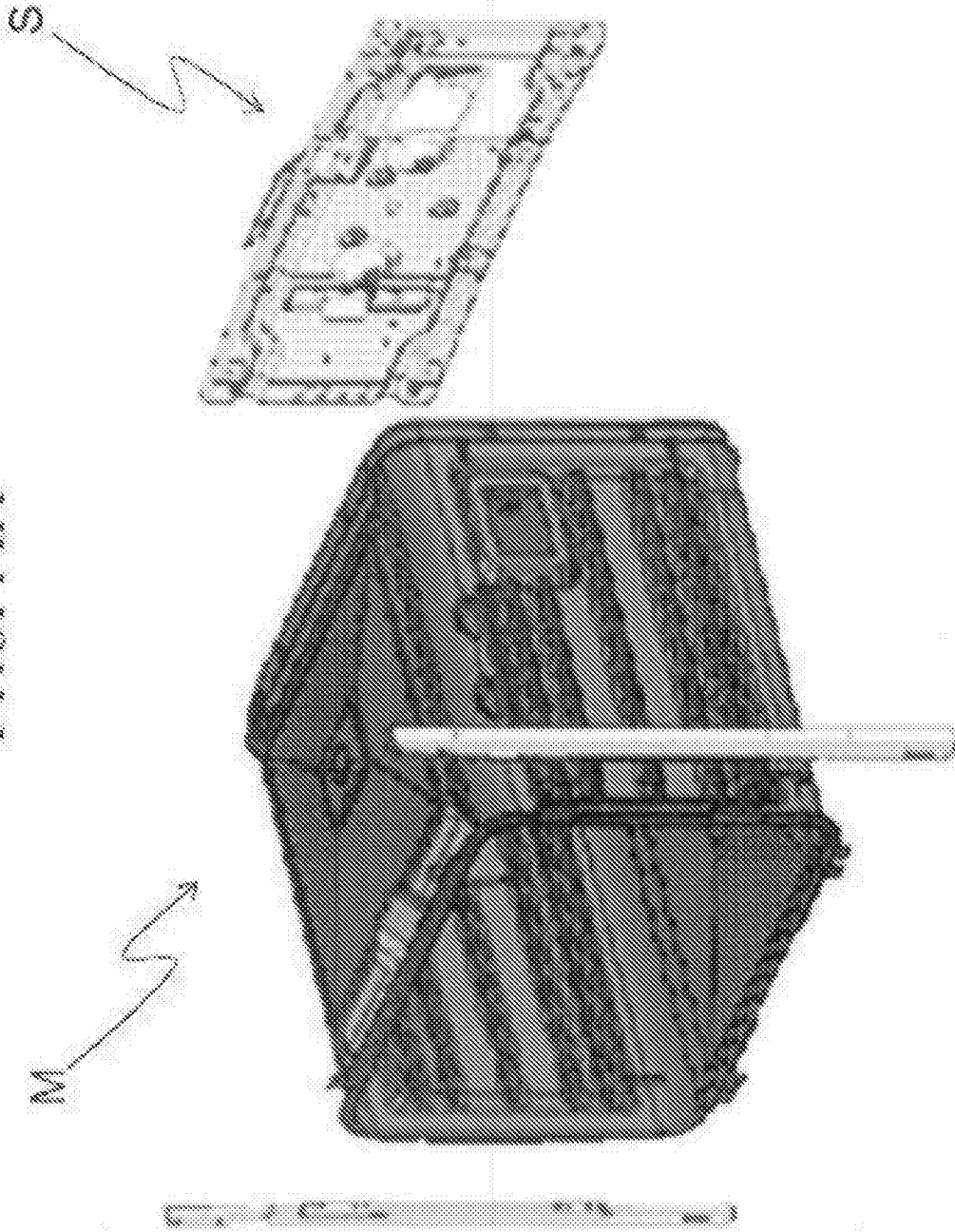

Fig. 1

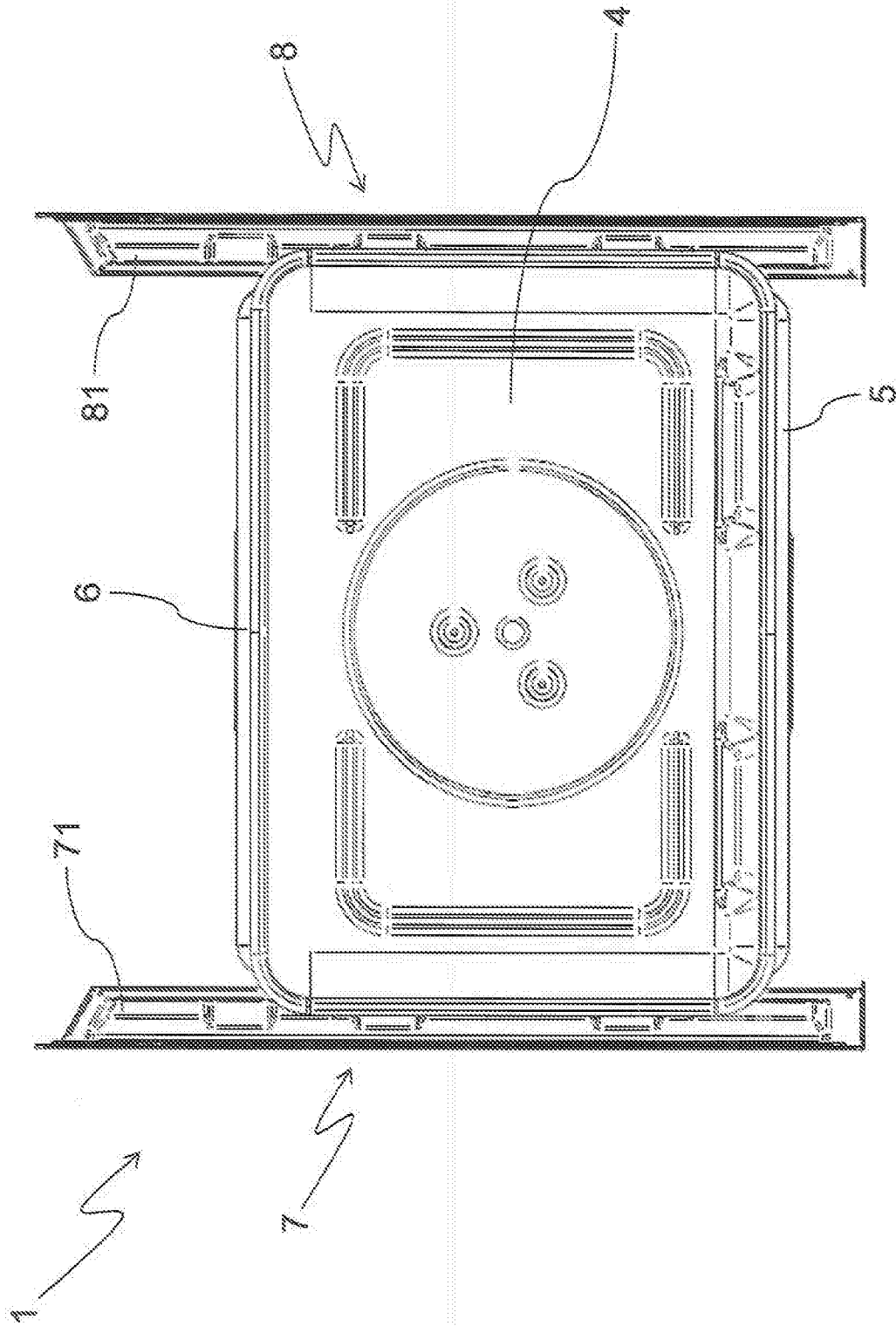

Fig. 2

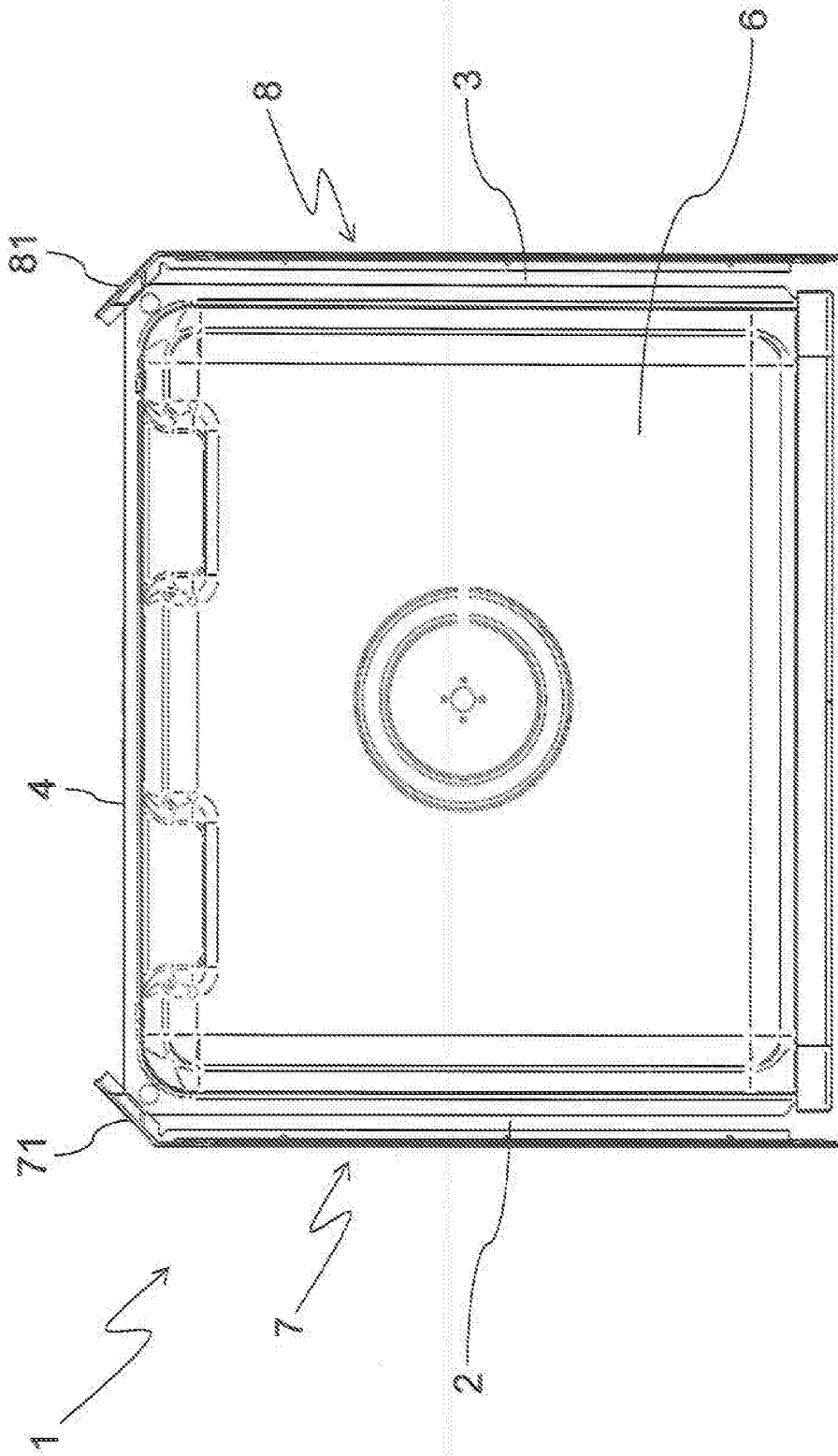

Fig. 3

