

(19)



(11)

EP 3 937 308 B1

(12)

EUROPEAN PATENT SPECIFICATION

(45) Date of publication and mention of the grant of the patent:
29.05.2024 Bulletin 2024/22

(51) International Patent Classification (IPC):
H01Q 5/40 ^(2015.01) **H01Q 9/40** ^(2006.01)
H01Q 9/42 ^(2006.01) **H01Q 1/32** ^(2006.01)

(21) Application number: **20184487.5**

(52) Cooperative Patent Classification (CPC):
H01Q 5/40; H01Q 9/40; H01Q 9/42; H01Q 1/3275

(22) Date of filing: **07.07.2020**

(54) **ANTENNA ASSEMBLY**

ANTENNENANORDNUNG

ENSEMBLE D'ANTENNES

(84) Designated Contracting States:
AL AT BE BG CH CY CZ DE DK EE ES FI FR GB GR HR HU IE IS IT LI LT LU LV MC MK MT NL NO PL PT RO RS SE SI SK SM TR

(74) Representative: **Delaval, Guillaume Laurent**
Valeo Comfort and Driving Assistance
6 rue Daniel Costantini
94000 Créteil (FR)

(43) Date of publication of application:
12.01.2022 Bulletin 2022/02

(56) References cited:
EP-A1- 2 091 103 **WO-A1-2007/034137**
US-A1- 2002 180 655 **US-A1- 2006 152 426**
US-A1- 2016 204 514

(73) Proprietor: **Valeo Comfort and Driving Assistance**
94000 Créteil (FR)

(72) Inventor: **KNOESS, Henning**
94046 Créteil CEDEX (FR)

EP 3 937 308 B1

Note: Within nine months of the publication of the mention of the grant of the European patent in the European Patent Bulletin, any person may give notice to the European Patent Office of opposition to that patent, in accordance with the Implementing Regulations. Notice of opposition shall not be deemed to have been filed until the opposition fee has been paid. (Art. 99(1) European Patent Convention).

Description

TECHNICAL FIELD OF THE INVENTION

[0001] The invention relates to the technological field of antennas.

[0002] More precisely the invention relates to a multi-layer antenna assembly.

BACKGROUND INFORMATION AND PRIOR ART

[0003] Nowadays, several antennas forming an antenna assembly can be integrated within the same electronic unit. In many telecommunication applications, for example in cellphones or in cars, an antenna assembly is arranged on a printed circuit board. Space-saving being a constant constraint in electronics and especially in telecommunications, the various antennas of an antenna assembly are arranged close to each other. Example of such antenna assemblies are known from WO 2007/034137 A1, EP 2 091 103 A1, US 2016/204514 A1, US 2002/180655 A1, and US 2006/152426 A1.

[0004] However, each antenna adds mechanical complexity to the antenna assembly. Moreover, each antenna is likely to reduce the coverage of the other antennas. In particular, the radiation performance of small antennas is strongly reduced when they are located next to large antennas. For example, in shark-fin antennas present on the roof of vehicles, the radiation performance of the smaller antenna working at high frequency for car-to-car communication is strongly affected by the larger cellular antenna working at lower frequencies.

SUMMARY OF THE INVENTION

[0005] In this context, the invention provide an antenna assembly defined in claim 1 comprising an insulating support comprising a first side and a second side facing away from said first side; a first antenna comprising a first layer arranged on said first side and a second layer arranged on said second side, at least one of said first layer and said second layer comprising a first feed connection for connecting said first antenna to a first signal source, at least one of said first layer and said second layer comprising a short connection for connecting said first antenna to a reference potential, said first layer and said second layer being conductively connected to each other; a second antenna comprising a second feed connection ; and a transmission line arranged at least partly on said first side across said first layer for connecting said second feed connection of said second antenna to a second signal source, said transmission line (40) extending across said short connection (61) of said first antenna (20), said first layer (21) comprising a first portion (23) and a second portion (24) separated from said first portion (23) and said transmission line (40) extending between said first portion (23) and said second portion (24).

[0006] Thanks to the transmission line extending

across the first layer of the first antenna, the second antenna can be located away from the feed and short connections of the first antenna, for example above the first antenna. On one hand, the mechanical complexity of the antenna assembly is therefore reduced and the radiation performance of the second antenna is improved. On the other hand, the first and second layers of the first antenna being conductively connected, the radiation performance of the first antenna remains virtually unchanged as compared with a configuration without the second antenna.

[0007] Indeed, in this antenna assembly, the radiating portion of the first antenna comprised between the feed connection and the short connection acts as a ground return path for a current injected in the transmission line and the second antenna. This common ground return path for the first and the second antenna prevents each antenna from interfering with the other antenna.

[0008] According to possible optional features:

- said transmission line is a grounded coplanar waveguide or a microstripline;
- said second antenna comprises another layer arranged on said insulating support;
- said another layer is arranged on said first side;
- said second antenna is located at least partly in close proximity to said first antenna;
- said first layer of said first antenna and said second layer of said first antenna are conductively connected by vias;
- the antenna assembly comprises a first filtering network and a second filtering network, and wherein said first filtering network links said first antenna to said reference potential and said second filtering network links said transmission line to said second signal source;
- said second feed connection is located away from said first feed connection;
- said insulating support comprises a first end where said first feed connection and said short connection are located and a second end opposed to said first end, where said transmission line connects to said second feed connection;
- the surface of said second antenna is smaller than the surface of said first antenna.

[0009] Other features and advantages of the embodiments of the present invention will be better understood upon reading of preferred embodiments thereof with reference to the appended drawings.

BRIEF DESCRIPTION OF THE DRAWINGS

[0010]

Figure 1 shows a front view in perspective of a first embodiment of an antenna assembly according to the invention;

Figure 2 shows a back view in perspective of the

antenna assembly of figure 1;

Figure 3 shows a front view of a part of a second embodiment of an antenna assembly according to the invention;

Figure 4 shows a back view of the part of the antenna assembly of figure 3.

DETAILED DESCRIPTION OF EXAMPLES

[0011] The following description, enriched with joint drawings that should be taken as non-limitative examples, will help understand the invention and figure out how it can be realized.

[0012] Although two embodiments of an antenna assembly according to the invention are shown in the figures, the same reference numbers will be used to throughout the description of these embodiments.

[0013] As shown in figures 1 and 2, the antenna assembly 1 comprises an insulating support 10, a first antenna 20, a second antenna 30 and a transmission line 40.

[0014] The insulating support 10 is a non-conductive substrate. Here, the insulating support 10 is made from an epoxy resin, which makes the insulating support 10 relatively rigid.

[0015] The insulating support 10 comprises a first side 11 and a second side 12 facing away from said first side 11. Here, the overall shape of the insulating support 10 is mainly a parallelepiped. More precisely, the insulating support 10 is here a thin rectangular parallelepiped with two main sides (i.e. the two sides with larger respective areas), the two main sides being the first side 11 and the second side 12.

[0016] As shown in figures 1 and 2, the insulating support 10 is fixed on a main printed circuit board 50. Here, the insulating support 10 extends in a plan perpendicular to the main printed circuit board 50. This means that the first side 11 and the second side 12 are perpendicular to the main printed circuit board 50. Such a configuration is for example used in shark-fin antennas in the car industry. The dimensions of the main printed circuit board 50 are for example comprised between 20 mm and 100 mm. Here, for example, the main printed circuit board is 50 mm over 55 mm wide.

[0017] According to a possible variation, the insulating support 10 may extend in a plane aligned with the main printed circuit board 50, as represented in figures 3 and 4, which reduces the number of interconnection components needed between the insulating support 10 and the main printed circuit board 50. In this configuration, the insulating support 10 may be an extension of the main printed circuit board 50.

[0018] According to another possible variation, the insulating support can also present an arbitrary shape. The insulating support can also be flexible, for example bent in three dimensions.

[0019] The main printed circuit board 50 may for example be part of a transmission control unit. As detailed

further, the main printed circuit board 50 allows connecting and using the antenna assembly 1. In other words, the antenna assembly 1 is electronically and mechanically connected to the main printed circuit board 50. Thus, the main printed circuit board 50 may for instance include radiofrequency circuits for controlling operation of the antenna assembly 1 and feeding circuits for feeding the first antenna 20 and the second antenna 30 from the radiofrequency circuits.

[0020] The first antenna comprises a first layer 21 arranged on the first side 11 and a second layer 22 arranged on the second side 12. The first layer 21 and the second layer 22 are for example copper layers printed on the insulating support 10.

[0021] The first layer 21 and the second layer 22 are conductively connected to each other. Here, for example, the first layer 21 and the second layer 22 are conductively connected by vias located all around the periphery of the first antenna 20. This allows increasing the radiation surface of the first antenna 20 and therefore the radiation performances of the first antenna 20. The vias 80 also increase the shielding effectiveness towards unwanted signals which could be present in-between the two layers 21, 22 of the first antenna 20.

[0022] The first layer 21 comprises a first portion 23 and a second portion 24 separated (i.e. at a distance) from each other on the first side 11. The first portion 23 and the second portion 24 are connected to each other by the vias which connect each portion 23 ; 24 to the second layer 22.

[0023] As represented in figures 1 and 2, the first antenna 20 covers a large portion of the insulating support 10, here approximately 50% of the surface of the insulating support 10. Here, the dimensions of the first antenna 20 are suited for emitting or receiving frequencies in the range from 600 MHz to 5 GHz. In this way, the first antenna is 40 mm to 50 mm wide. The dimensions of the first antenna 20 are for example 48 mm over 47 mm.

[0024] In order to emit radiofrequency waves, the first layer 21 and/or the second layer 22 of the first antenna 20 comprises a feed connection 60, referred to as a first feed connection 60, connecting the first antenna 20 to a first signal source. This first feed connection 60 is for instance located at an end of one of the feeding circuits mentioned above.

[0025] The first layer 21 and/or the second layer 22 the first antenna 20 also comprises a short connection 61 connecting the first antenna 20 to a reference potential, for example to ground.

[0026] As represented in figure 1, the first feed connection 60 of the first antenna 20 is a conductive track or another transmission line connecting the first antenna 20 to the main printed circuit board 50. Here, the first feed connection 60 is located at the level of the main printed circuit board 50. The first signal source is for example a first radiofrequency circuit arranged on the main printed circuit board 50. The first feed connection 60 can connect the first antenna 20 to the first radiofrequency

circuit (through a feeding circuit as mentioned above) to emit or to receive a radiofrequency signal.

[0027] Here, as shown in figure 1, the second antenna 30 comprises one layer 31 arranged on the insulating support 10. Here the second antenna 30 is arranged on the first side 11 of the insulating support 10. The second antenna 30 also comprises a feed connection 65, referred to a second feed connection 65.

[0028] As a variation, the second antenna could be arranged on the first side and on the second side of the insulating support and therefore would comprise two layers. The second antenna could also be arranged on another insulating support, for example facing the insulating support at a short distance.

[0029] In any case, the second antenna 30 may be located at least partly in close proximity to the first antenna 20 such that the second antenna 30 is connected contactless with the reference potential through a near-field interaction with the first antenna 20. Here, "in close proximity" means that the second antenna 30 is located closer than 10 mm away from the first antenna 20.

[0030] The surface of the second antenna 30 is smaller than the surface of the first antenna 20. Indeed, the dimensions of the second antenna 30 are suited for emitting or receiving frequencies at 5.9 GHz. For example, the surface of the first antenna 20 is higher than 20 cm² while the surface of the second antenna 30 is lower than 5 cm². In this way, here, the second antenna 30 is 7 mm to 10 mm wide.

[0031] By its dimensions, the first antenna 20 is not designed for the frequencies of the second antenna 30 and vice versa. This prevents the first antenna 20 and the second antenna 30 from interfering with each other's.

[0032] The transmission line 40 connects the feed connection 65 of the second antenna 30 to a second signal source. So here, as represented in figure 1, the transmission line 40 is arranged at least partly on the first side 11. The transmission line 40 is also arranged across the first layer 21.

[0033] The transmission line 40 is adapted to transport a current from the second signal source to the feed of the second antenna 30. The transmission line 40 is designed to conduct an alternating current of a radiofrequency signal at high frequency.

[0034] Thanks to the transmission line 40 extending across a layer of the first antenna 20, here across the first layer 21, a radiating portion of the first antenna 20, here the first layer 21 and the second layer 22, can act as a ground return path for the second antenna 30. In other words, the transmission line 40 uses the radiating portion of the first antenna 20 to carry over the energy to the second feed connection 65 of the second antenna 30 because the first antenna 20 is the dominating ground potential for the second antenna 30.

[0035] The first layer 21 and the second layer 22 being conductively connected by the vias, the first layer 21 is not impaired by the transmission line 21. Thanks to the vias 80, there is an interconnection between the layers

21, 22 and the reference potential around and along the transmission line 40.

[0036] Thanks to the transmission line 40 extending across a layer of the first antenna 20, the transmission line 40 is arranged in close proximity with the first antenna 20. In this way, the first antenna 20 provides a ground return path for a current circulating in the transmission line 40.

[0037] The transmission line 40 also allows arranging the second antenna 30 away from the first feed connection 60 and the short connection 61 of the first antenna 20.

[0038] Here, the relative position of the second antenna 30 with respect to the first antenna 20 is determined such that the impedance of the second antenna 20 is high for the operating frequencies of the first antenna 20. This prevents the first antenna 20 and the second antenna 30 from interfering with each other's.

[0039] The transmission line 40 is for example a grounded coplanar waveguide or a microstrip line.

[0040] As represented in figures 1 and 3, the transmission line 40 extends more specifically between the first portion 23 and the second portion 24 of the first layer 21.

[0041] Here, the transmission line 40 also extends across the short connection 61 of the first antenna 20.

As shown in figure 1, on the first side 11, the short connection 61 comprises two portions separated from each other on the first side 11 and the transmission line 40 extends between those two portions. The two portions of the short connection 61 are connected to each other by the vias 80 and the second layer 22. In this way, the transmission line 40 enters the structure of the first antenna 20 at a location where the first antenna 20 is connected to the reference potential. This prevents the two antennas 20, 30 from interfering with each other.

[0042] Thanks to the transmission line 40, the second feed connection 65 can be located away from said first feed connection 60. The second feed connection 65 is for example located farther than 15 mm away from the first feed connection 60, and preferably farther than 20 mm away from the first feed connection 60.

[0043] As shown in figure 1, the insulating support 10 comprises a first end 13 where the first feed connection 60 and the short connection 61 are located and a second end 14, opposed to the first end 13, where the transmission line 40 connects to the second feed connection 65 of the second antenna 30. Here, the first end 13 is located at the main printed circuit board 50 level and the second end 14 is located at an elevated position with respect to the main printed circuit board 50 level.

[0044] So, thanks to the transmission line 40, the second antenna 30 can be located above the first antenna 20 relative to the main printed circuit board 50 (in configurations where the insulating support 10 is arranged vertically, as for a shark-fin antenna). This positioning improves the radiation performances of the second antenna 30.

[0045] In a first embodiment represented in figures 1 and 2, the short connection 61 is a conductive track. Here,

this conductive track connects the first antenna 20 to the reference potential or the ground of the main printed circuit board 50.

[0046] In this first embodiment, the transmission line 40 is connected to the second signal source by a conductive track 41. The second signal source is for example a second radiofrequency circuit arranged on the main printed circuit board 50. The transmission line 40 can connect the second antenna 30 to the second radiofrequency circuit to emit or to receive a radiofrequency signal.

[0047] In a second embodiment represented in figures 3 and 4, the antenna assembly 1 comprises a first filtering network 70 and a second filtering network 71. The filtering networks 70, 71 can be used when no connection to the ground for the first antenna 20 is available.

[0048] The first filtering network 70 links the first antenna 20 to the reference potential. Here, the first filtering network 70 links the second layer 22 of the first antenna 20 to the reference potential or the ground of the main printed circuit board 50.

[0049] In the second embodiment, as represented on figure 3, the second filtering network 71 links the transmission line 40, and so the second antenna 30, to the second signal source.

[0050] The first filtering network 70 and the second filtering network 71 are high-pass filters. In this way, they can transfer the operating frequencies of the second antenna 30 and block partially or completely the operating frequencies of the first antenna 20.

[0051] In this embodiment, thanks to the first filtering network 70 and to the second filtering networks 71, the transmission line 40 and the ground return path of the second antenna 30 can be connected to the second signal source even so there is no short connection available for the first antenna 20.

[0052] Therefore, the filtering networks 70, 71 provides a high pass characteristic which let the signal pass for the second antenna 30 and block the signal for the first antenna 20. By doing so, the first antenna 20 is not disturbed by the additional connections due to the filtering networks 70, 71.

[0053] The first filtering network 70 and the second filtering network 71 can for example be formed with discrete components, integrated components, with a coupling structure build within a layer 21, 22, 31 of the first antenna 20 and/or of the second antenna 30 and/or within a layer of the main printed circuit board 50, or with any combination of these three technics.

[0054] The antenna assembly 1 is not limited to two antennas 20, 30. Indeed, it is possible to stack several antennas on top of one antenna or to stack several antennas on top of each other in a cascade.

Claims

1. Antenna assembly (1) comprising:

- an insulating support (10) comprising a first side (11) and a second side (12) facing away from said first side (11);
- a first antenna (20) comprising a first layer (21) arranged on said first side (11) and a second layer (22) arranged on said second side (12), at least one of said first layer (21) and said second layer (22) comprising a first feed connection (60) for connecting said first antenna (20) to a first signal source, at least one of said first layer (21) and said second layer (22) comprising a short connection (61) for connecting said first antenna (20) to a reference potential, said first layer (21) and said second layer (22) being conductively connected to each other;
- a second antenna (30) comprising a second feed connection (65); and
- a transmission line (40) arranged at least partly on said first side (11) across said first layer (21) for connecting said second feed connection (65) of said second antenna (30) to a second signal source, said transmission line (40) extending across said short connection (61) of said first antenna (20), wherein said first layer (21) comprises a first portion (23) and a second portion (24) separated from said first portion (23) and wherein said transmission line (40) extends between said first portion (23) and said second portion (24).

2. Antenna assembly (1) according to claim 1, wherein said transmission line (40) is a grounded coplanar waveguide or a microstripline.
3. Antenna assembly (1) according to anyone of claims 1 to 2, wherein said second antenna (30) comprises another layer (31) arranged on said insulating support (10).
4. Antenna assembly (1) according to claim 3, wherein said another layer (31) is arranged on said first side (11).
5. Antenna assembly (1) according to anyone of claims 1 to 4, wherein said second antenna (30) is located at least partly in close proximity to said first antenna (20).
6. Antenna assembly (1) according to anyone of claims 1 to 5, wherein said first layer (21) of said first antenna (20) and said second layer (22) of said first antenna (20) are conductively connected by vias (80).
7. Antenna assembly (1) according to anyone of claims 1 to 6, comprising a first filtering network (70) and a second filtering network (71), and wherein said first filtering network (70) is configured to link said first

antenna (20) to said reference potential and said second filtering network (71) is configured to link said transmission line (40) to said second signal source.

8. Antenna assembly (1) according to anyone of claims 1 to 7, wherein said second feed connection (65) is located away from said first feed connection (60).
9. Antenna assembly (1) according to anyone of claims 1 to 8, wherein said insulating support (10) comprises a first end (13) where said first feed connection (60) and said short connection (61) are located and a second end (14) opposed to said first end (13), where said transmission line (40) connects to said second feed connection (65).
10. Antenna assembly (1) according to anyone of claims 1 to 9, wherein the surface of said second antenna (30) is smaller than the surface of said first antenna (20).

Patentansprüche

1. Antennenanordnung (1), die Folgendes umfasst:

- einen isolierenden Träger (10), der eine erste Seite (11) und eine von der ersten Seite (11) abgewandte zweite Seite (12) umfasst;
- eine erste Antenne (20), die eine auf der ersten Seite (11) angeordnete erste Schicht (21) und eine auf der zweiten Seite (12) angeordnete zweite Schicht (22) umfasst, wobei mindestens eine von der ersten Schicht (21) und der zweiten Schicht (22) einen ersten Speiseanschluss (60) zum Anschließen der ersten Antenne (20) an eine erste Signalquelle umfasst, wobei mindestens eine von der ersten Schicht (21) und der zweiten Schicht (22) einen Kurzschluss (61) zum Anschließen der ersten Antenne (20) an ein Bezugspotenzial umfasst, wobei die erste Schicht (21) und die zweite Schicht (22) leitend miteinander verbunden sind;
- eine zweite Antenne (30), die einen zweiten Speiseanschluss (65) umfasst; und
- eine Übertragungsleitung (40), die zumindest teilweise auf der ersten Seite (11) über die erste Schicht (21) zum Anschließen des zweiten Speiseanschlusses (65) der zweiten Antenne (30) an eine zweite Signalquelle angeordnet ist, wobei sich die Übertragungsleitung (40) über den Kurzschluss (61) der ersten Antenne (20) erstreckt, wobei die erste Schicht (21) einen ersten Abschnitt (23) und einen von dem ersten Abschnitt (23) beabstandeten zweiten Abschnitt (24) umfasst und wobei sich die Übertragungsleitung (40) zwischen dem ersten Abschnitt (23) und dem zweiten Abschnitt (24) erstreckt.

2. Antennenanordnung (1) nach Anspruch 1, wobei die Übertragungsleitung (40) ein koplanarer Wellenleiter mit Masseanschluss oder eine Mikrostreifenleitung ist.

3. Antennenanordnung (1) nach einem der Ansprüche 1 bis 2, wobei die zweite Antenne (30) eine weitere auf dem isolierenden Träger (10) angeordnete Schicht (31) umfasst.

4. Antennenanordnung (1) nach Anspruch 3, wobei die weitere Schicht (31) auf der ersten Seite (11) angeordnet ist.

5. Antennenanordnung (1) nach einem der Ansprüche 1 bis 4, wobei sich die zweite Antenne (30) zumindest teilweise in unmittelbarer Nähe der ersten Antenne (20) befindet.

6. Antennenanordnung (1) nach einem der Ansprüche 1 bis 5, wobei die erste Schicht (21) der ersten Antenne (20) und die zweite Schicht (22) der ersten Antenne (20) über Verbindungslöcher (80) leitend verbunden sind.

7. Antennenanordnung (1) nach einem der Ansprüche 1 bis 6, die ein erstes Filternetzwerk (70) und ein zweites Filternetzwerk (71) umfasst und wobei das erste Filternetzwerk (70) konfiguriert ist, um die erste Antenne (20) mit dem Bezugspotenzial zu verbinden, und das zweite Filternetzwerk (71) konfiguriert ist, um die Übertragungsleitung (40) mit der zweiten Signalquelle zu verbinden.

8. Antennenanordnung (1) nach einem der Ansprüche 1 bis 7, wobei sich der zweite Speiseanschluss (65) von dem ersten Speiseanschluss (60) entfernt befindet.

9. Antennenanordnung (1) nach einem der Ansprüche 1 bis 8, wobei der isolierende Träger (10) ein erstes Ende (13), wo sich der erste Speiseanschluss (60) und der Kurzschluss (61) befinden, und ein zweites Ende (14) gegenüber dem ersten Ende (13), wo die Übertragungsleitung (40) an den zweiten Speiseanschluss (65) anschließt, umfasst.

10. Antennenanordnung (1) nach einem der Ansprüche 1 bis 9, wobei die Oberfläche der zweiten Antenne (30) kleiner als die Oberfläche der ersten Antenne (20) ist.

Revendications

1. Ensemble (1) d'antennes comportant :

- un support isolant (10) comportant une premiè-

- re face (11) et une seconde face (12) orientée à l'opposé de ladite première face (11) ;
- une première antenne (20) comportant une première couche (21) disposée sur ladite première face (11) et une seconde couche (22) disposée sur ladite seconde face (12), au moins une couche parmi ladite première couche (21) et ladite seconde couche (22) comportant une première connexion (60) d'alimentation servant à relier ladite première antenne (20) à une première source de signal, au moins une couche parmi ladite première couche (21) et ladite seconde couche (22) comportant une connexion courte (61) servant à relier ladite première antenne (20) à un potentiel de référence, ladite première couche (21) et ladite seconde couche (22) étant reliées l'une à l'autre de manière conductrice ;
 - une seconde antenne (30) comportant une seconde connexion (65) d'alimentation ; et
 - une ligne (40) de transmission disposée au moins en partie sur ladite première face (11) en travers de ladite première couche (21) servant à relier ladite seconde connexion (65) d'alimentation de ladite seconde antenne (30) à une seconde source de signal, ladite ligne (40) de transmission s'étendant en travers de ladite connexion courte (61) de ladite première antenne (20), ladite première couche (21) comportant une première partie (23) et une seconde partie (24) séparée de ladite première partie (23) et ladite ligne (40) de transmission s'étendant entre ladite première partie (23) et ladite seconde partie (24).
2. Ensemble (1) d'antennes selon la revendication 1, ladite ligne (40) de transmission étant un guide d'onde coplanaire mis à la terre ou une ligne à micro-ruban.
3. Ensemble (1) d'antennes selon l'une quelconque des revendications 1 à 2, ladite seconde antenne (30) comportant une autre couche (31) disposée sur ledit support isolant (10).
4. Ensemble (1) d'antennes selon la revendication 3, ladite autre couche (31) étant disposée sur ladite première face (11).
5. Ensemble (1) d'antennes selon l'une quelconque des revendications 1 à 4, ladite seconde antenne (30) étant située au moins en partie à proximité immédiate de ladite première antenne (20).
6. Ensemble (1) d'antennes selon l'une quelconque des revendications 1 à 5, ladite première couche (21) de ladite première antenne (20) et ladite seconde couche (22) de ladite première antenne (20) étant
- reliées de manière conductrice par des traversées (80).
7. Ensemble (1) d'antennes selon l'une quelconque des revendications 1 à 6, comportant un premier réseau (70) de filtrage et un second réseau (71) de filtrage, et ledit premier réseau (70) de filtrage étant configuré pour relier ladite première antenne (20) audit potentiel de référence et ledit second réseau (71) de filtrage étant configuré pour relier ladite ligne (40) de transmission à ladite seconde source de signal.
8. Ensemble (1) d'antennes selon l'une quelconque des revendications 1 à 7, ladite seconde connexion (65) d'alimentation étant située à l'écart de ladite première connexion (60) d'alimentation.
9. Ensemble (1) d'antennes selon l'une quelconque des revendications 1 à 8, ledit support isolant (10) comportant une première extrémité (13) où sont situées ladite première connexion (60) d'alimentation et ladite connexion courte (61) et une seconde extrémité (14) opposée à ladite première extrémité (13), où ladite ligne (40) de transmission se raccorde à ladite seconde connexion (65) d'alimentation.
10. Ensemble (1) d'antennes selon l'une quelconque des revendications 1 à 9, la surface de ladite seconde antenne (30) étant plus petite que la surface de ladite première antenne (20).

Fig.1

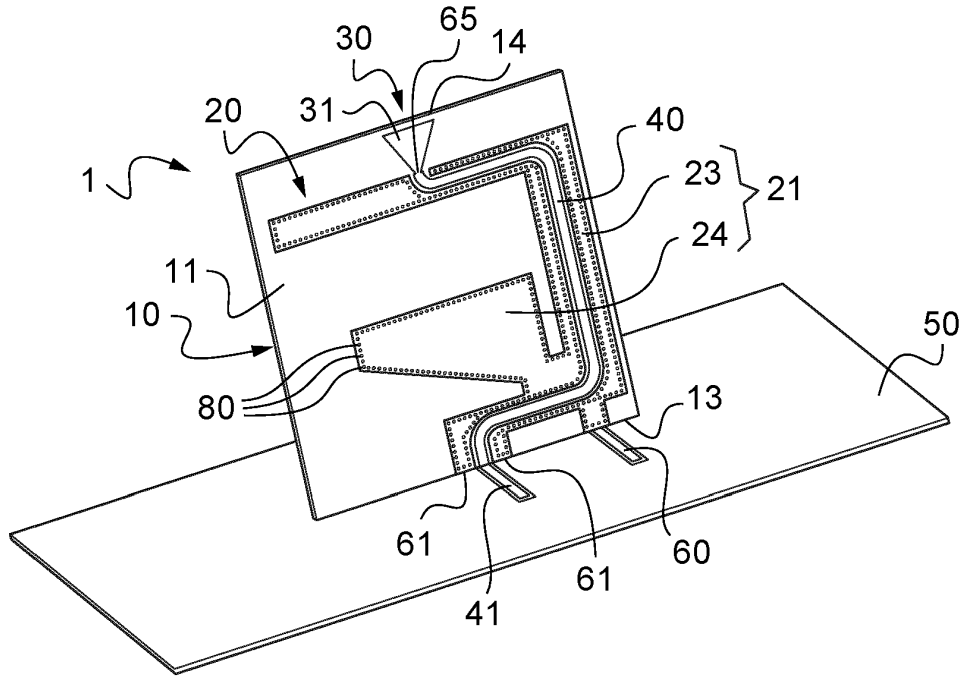

Fig.2

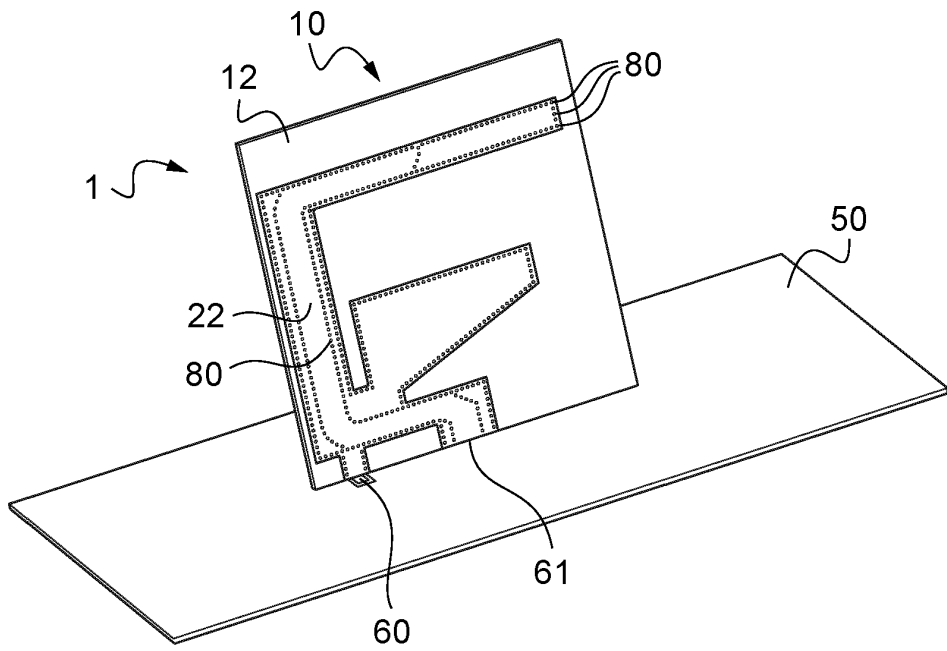

Fig.3

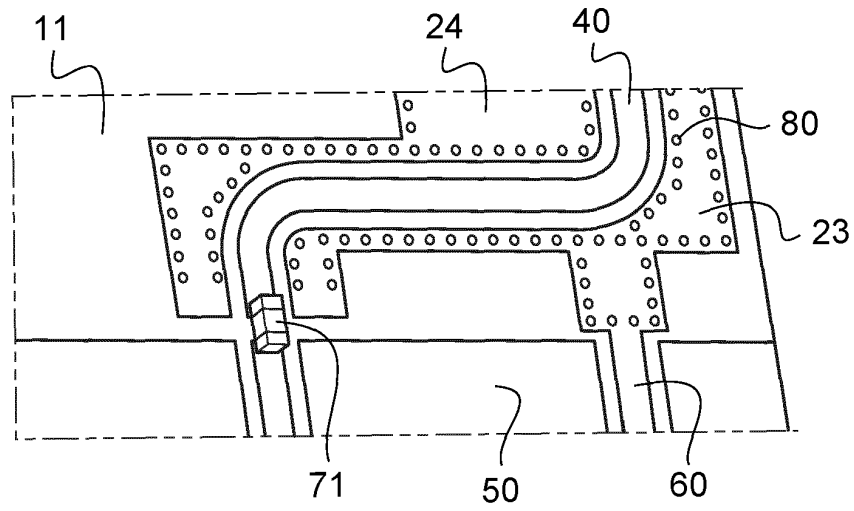
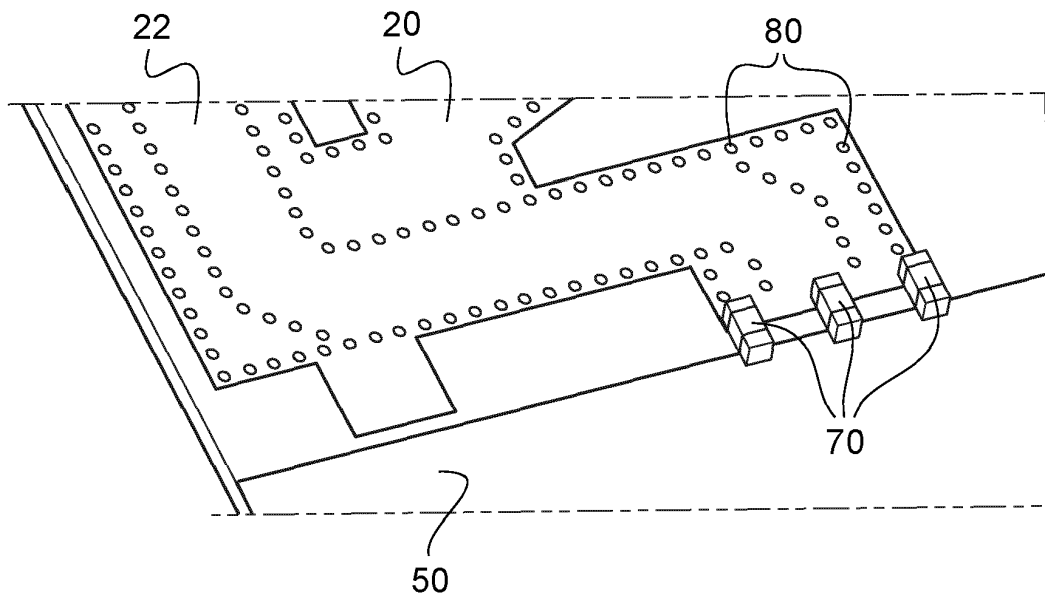

Fig.4



REFERENCES CITED IN THE DESCRIPTION

This list of references cited by the applicant is for the reader's convenience only. It does not form part of the European patent document. Even though great care has been taken in compiling the references, errors or omissions cannot be excluded and the EPO disclaims all liability in this regard.

Patent documents cited in the description

- WO 2007034137 A1 [0003]
- EP 2091103 A1 [0003]
- US 2016204514 A1 [0003]
- US 2002180655 A1 [0003]
- US 2006152426 A1 [0003]