

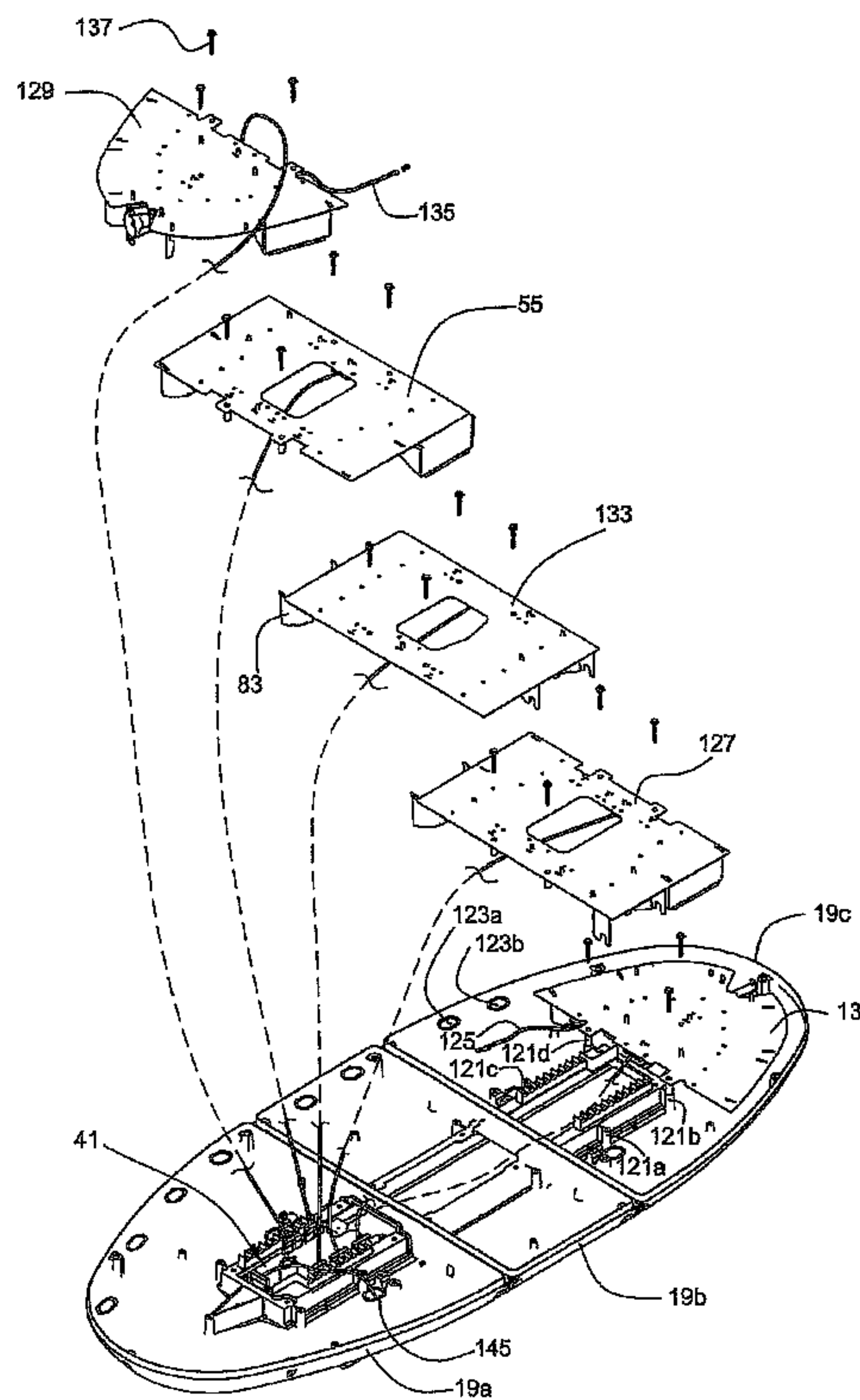

(86) Date de dépôt PCT/PCT Filing Date: 2007/03/15  
 (87) Date publication PCT/PCT Publication Date: 2007/10/18  
 (45) Date de délivrance/Issue Date: 2016/01/05  
 (85) Entrée phase nationale/National Entry: 2008/09/30  
 (86) N° demande PCT/PCT Application No.: US 2007/064088  
 (87) N° publication PCT/PCT Publication No.: 2007/117854  
 (30) Priorité/Priority: 2006/03/31 (US11/394,752)

(51) Cl.Int./Int.Cl. *B60Q 1/00* (2006.01)  
 (72) Inventeurs/Inventors:  
 GERGETS, PAUL M., US;  
 FLESZEWSKI, VINCE S., US;  
 MOSTELLO, ALLAN J., US  
 (73) Propriétaire/Owner:  
 FEDERAL SIGNAL CORPORATION, US  
 (74) Agent: MARKS & CLERK

(54) Titre : BARRE LUMINEUSE ET PROCEDE DE FABRICATION  
 (54) Title: LIGHT BAR AND METHOD FOR MAKING



(57) Abrégé/Abstract:

A light bar is described that is of a modular construction based on one or more large circuit boards that are populated with light beam assemblies and then fastened to an interior space of the light bar housing. Keys that automatically align the light beam assemblies on each of the boards precisely control placement of the assemblies on the board. In turn, each of the boards is keyed to the interior of the light bar housing so that when the board is fastened to the housing the light beam assemblies are automatically registered into alignment with the lenses in the housing so that the beams from the assemblies are properly oriented. The light bar is inexpensive to fabricate and can be assembled quickly and reliably, yet it provides for a high degree of customization, which is a requirement in the emergency vehicle lighting industry.

(12) INTERNATIONAL APPLICATION PUBLISHED UNDER THE PATENT COOPERATION TREATY (PCT)

(19) World Intellectual Property Organization  
International Bureau(43) International Publication Date  
18 October 2007 (18.10.2007)

PCT

(10) International Publication Number  
**WO 2007/117854 A3**(51) International Patent Classification:  
*B60Q 1/00* (2006.01)Allan J. [US/US]; 3283 Rustic Lane, Crown Point, Indiana  
46307 (US).(21) International Application Number:  
PCT/US2007/064088(74) Agents: CONKLIN, John B. et al.; Two Prudential Plaza,  
180 N. Stetson Ave., Suite 4900, Chicago, Illinois 60601-  
6731 (US).

(22) International Filing Date: 15 March 2007 (15.03.2007)

(25) Filing Language: English

(81) Designated States (*unless otherwise indicated, for every  
kind of national protection available*): AE, AG, AL, AM,  
AT, AU, AZ, BA, BB, BG, BR, BW, BY, BZ, CA, CH, CN,  
CO, CR, CU, CZ, DE, DK, DM, DZ, EC, EE, EG, ES, FI,  
GB, GD, GE, GH, GM, GT, HN, HR, HU, ID, IL, IN, IS,  
JP, KE, KG, KM, KN, KP, KR, KZ, LA, LC, LK, LR, LS,  
LT, LU, LY, MA, MD, MG, MK, MN, MW, MX, MY, MZ,  
NA, NG, NI, NO, NZ, OM, PG, PH, PL, PT, RO, RS, RU,  
SC, SD, SE, SG, SK, SL, SM, SV, SY, TJ, TM, TN, TR,  
TT, TZ, UA, UG, US, UZ, VC, VN, ZA, ZM, ZW.

(26) Publication Language: English

(30) Priority Data:  
11/394,752 31 March 2006 (31.03.2006) US(71) Applicant (*for all designated States except US*): FED-  
ERAL SIGNAL CORPORATION [US/US]; 1415 West  
22nd Street, Regency Towers, Suite 1100, Oakbrook, Illi-  
nois 60523 (US).

(72) Inventors; and

(75) Inventors/Applicants (*for US only*): GERGETS, Paul  
M. [US/US]; 9446 Villagio Way, Saint John, Indiana 46373  
(US). FLESZEWSKI, Vince S. [US/US]; 11352 Hobart  
Place, Crown Point, Indiana 46307 (US). MOSTELLO,(84) Designated States (*unless otherwise indicated, for every  
kind of regional protection available*): ARIPO (BW, GH,  
GM, KE, LS, MW, MZ, NA, SD, SL, SZ, TZ, UG, ZM,  
ZW), Eurasian (AM, AZ, BY, KG, KZ, MD, RU, TJ, TM),  
European (AT, BE, BG, CH, CY, CZ, DE, DK, EE, ES, FI,

[Continued on next page]

(54) Title: LIGHT BAR AND METHOD FOR MAKING

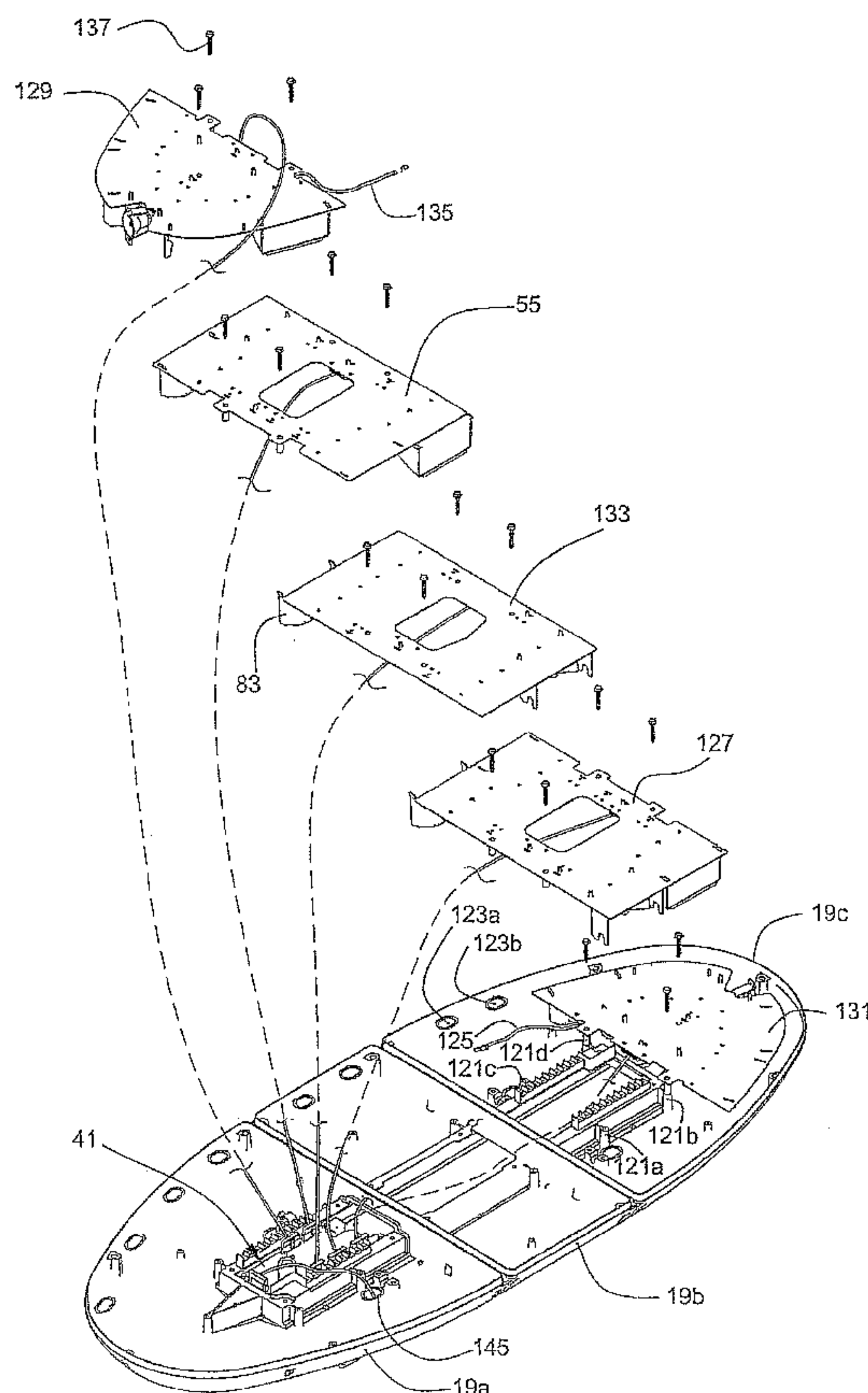

(57) Abstract: A light bar is described that is of a modular construction based on one or more large circuit boards that are populated with light beam assemblies and then fastened to an interior space of the light bar housing. Keys that automatically align the light beam assemblies on each of the boards precisely control placement of the assemblies on the board. In turn, each of the boards is keyed to the interior of the light bar housing so that when the board is fastened to the housing the light beam assemblies are automatically registered into alignment with the lenses in the housing so that the beams from the assemblies are properly oriented. The light bar is inexpensive to fabricate and can be assembled quickly and reliably, yet it provides for a high degree of customization, which is a requirement in the emergency vehicle lighting industry.

WO 2007/117854 A3

**WO 2007/117854 A3**



FR, GB, GR, HU, IE, IS, IT, LT, LU, LV, MC, MT, NL, PL,  
PT, RO, SE, SI, SK, TR), OAPI (BF, BJ, CF, CG, CI, CM,  
GA, GN, GQ, GW, ML, MR, NE, SN, TD, TG).

— *with amended claims*

**Published:**

— *with international search report*

**(88) Date of publication of the international search report:**  
10 April 2008

**Date of publication of the amended claims:** 12 June 2008

LVM 701305

## LIGHT BAR AND METHOD FOR MAKING

### TECHNICAL FIELD

The invention is generally directed to signaling systems for emergency vehicles and, more particularly, to warning light assemblies for mounting to emergency vehicles.

### BACKGROUND OF THE INVENTION

[0001] A common type of emergency warning system for a vehicle is commonly called a "light bar." Typically light bars are mounted to roofs of vehicles and wired to power sources in the engine compartments and controlled from control heads mounted in the passenger compartments.

[0002] Customer demands have driven light bars toward highly customizable designs. Manufacturers of light bars often start with a standard housing and then offer an array of alternative types of lighting devices to populate the interior of the light bar. For example, customers may ask for different mixes of takedown lights and alley lights, whose functions are suggested by their names. Customers may also ask for lights of different colors and different types of light sources such as light emitting diodes (LEDs), halogen lights, strobes or even lasers. Furthermore, the lighting assemblies may be fixed, rotating or oscillating.

[0003] To accommodate the demands of customers, the interiors of light bars are typically designed to provide flexibility for substituting different lighting devices as specified by the customer. Often the interior spaces of light bars house an assortment of individual light assemblies and wires to each assembly with associated connectors, making the interiors densely packed with complex wiring schemes.

[0004] These designs have evolved into highly complex interiors that are time consuming to assemble and tend to discourage automation of the assembly. Because the manufacturing process remains dependent on manual assembly, there is a higher than desirable risk of errors in the manufacturing process.

[0005] In addition to presenting manufacturing challenges, the multiple connections in the wiring schemes of the interior spaces of light bars create points of potential mechanical and

*LVM 701305*

2

electrical failure. Multiple individual wire connectors may fail because of vibration, the stress of temperature cycling, accidental tensioning of the wire during assembly or repair and other common sources of wear and tear. Servicing these many mechanical connections disrupts service and gives rise to reliability issues. Also, service requirements add expense to the light bar.

#### BRIEF SUMMARY OF THE INVENTION

[0006] The light bar of the invention is of a substantially modular construction based on mounting two or more light beam assemblies on a single circuit board. Each board is fabricated with keys that either guide or dictate a precise mounting of the light beam assemblies onto the board. In addition, the circuit boards are keyed to mounting surfaces in the housing of the light bar so that the circuit boards are precisely mounted with respect within the cavity of light bar housing. This dual registration of the light beam assemblies on the circuit boards and the boards in the cavity of the light bar results in a reliable and repeatable registration of the light beam assemblies with the lenses of the light bar housing. Moreover, by providing circuit boards that mount more than one light beam assembly, the invention substantially reduces the amount of loose wiring in the cavity of the light bar housing.

[0007] Each circuit board includes areas or stations defined by keys in its surface that assist aligning and attaching two or more light beam assemblies to the board. The keys pilot the light beam assemblies to be mounted at precise locations on the circuit board that register the assemblies in a desired, predetermined position. Each of the light beam assemblies includes keys complementing at least some of the keys in the circuit board such that engagement of the complementing keys registers the assembly at the predetermined position on the board.

[0008] The housing for the light bar and the circuit boards each include complementing keys that pilot the mounting of the circuit boards to the interior of the housing such that the circuit boards are mounted in a precise way that registers to the light beam assemblies on the boards to lenses in the housing. Thus, by keying to the light beam assemblies to the boards and the boards to the interior of the light bar housing, the light beam assemblies are automatically optically registered and otherwise properly positioned when the circuit boards are added to the interior of the light bar. The circuit boards include leads that communicate power and control signals from

*LVM 701305*

3

a connector. A cable from the connector on each of the circuit boards electrically connects the light beam assemblies on the board to sources of power and control signals.

[0009] In one embodiment, the complementing keys include one or more pairs of mating holes and posts. In another embodiment, the complementing keys include one or more pairs of holes in the circuit board and the light beam assemblies, where each pair of holes aligns to receive a fastener attaching a light beam assembly to the circuit board. Preferably, each key defining a precise position within an area or station on the circuit board for mounting a light beam assembly comprises a pattern of holes and posts or holes in the board that match a complementing pattern of holes and posts or holes in the light beam assembly. The keys can be anything (e.g., markings on the circuit board surface outlining a footprint of the matching light beam device) that helps or guides an assembler precisely mount the light beam assemblies onto the circuit board. In the illustrated embodiment described hereinafter, the keys are holes fabricated in the circuit board to form patterns that match holes and posts formed in the light beam assemblies.

[0010] The keys on the circuit board at each area or station for mounting a light beam assembly may be the same for different types of assemblies or each assembly may mate to a unique pattern of the keys. Either way, the keys for each area or station on the circuit board are for alternative types of the one or more light beam assemblies such that the keys pilot and register a selected one of the alternative types of assemblies to the predetermined position on the circuit board for selected type of assembly. In the illustrated embodiment, the keys for each location pilot and register either a light beam assembly for a solid state light source or for a gas-filled tube light source.

[0011] Preferably, the circuit board is a thermally conductive circuit board sourced from any of several vendors that communicates control signals to the light beam assemblies, sinks and radiates heat generated by the assemblies and provides mechanical and electrical stability over the environmental conditions to which the light bar is exposed. In the illustrated embodiment of the invention, each of the circuit boards is connected to a controller by a single cable. The controller delivers power and control signals to each of the circuit boards via the single cable connection. In turn, the controller receives power and control signals from a power source and a control head, respectively. The power source may be a battery such as the vehicle's battery or it

*LVM 701305*

may be a fuel cell, battery, ultra capacitor (e.g., Maxwell Technologies, San Diego, California) or an array of solar cells. In one embodiment of the invention, the power source is located at the light bar so that power line cables running from the vehicle to the light bar are not required. In this regard, the light bar is made entirely wireless by adding a receiver to the light bar that receives low energy radio frequency (RF) signals from a transmitter associated with the control head.

**[0012]** Many different types of light beam assemblies are suitable for mounting to the circuit boards. For example, the light beam assemblies may be solid state devices such as light emitting diodes (LEDs) or solid state lasers. They may be gas-filled tube such as halogen lamps, strobe lamps, high intensity discharge (HID) lamps, incandescent lamps or light engines. For LED-based light beam assemblies, the LEDs are preferably directly mounted to the circuit board in order to take advantage of the heat sinking capabilities of the circuit board.

**[0013]** All of the light beam assemblies are mounted to the circuit board and each of the circuit boards is preferably positioned in the housing such that its planar surface is oriented substantially horizontally when the light bar is mounted in an operational position. The boards are mounted in a co-planar manner or they may be stacked. Furthermore, the circuit boards may be angled at their ends for either structural support or for properly orienting light sources so their beams are directed into a lens of the light of the light bar without requiring reflectors to orient the beams.

**[0014]** In one embodiment of the invention, each of the circuit boards attaches to the housing of the light bar so that the light beam assemblies are oriented upside down such that, when the bar is viewed from above, the backplanes of the circuit boards are visible and effectively shield an interior space of the housing, which includes the light beam assemblies.

**[0015]** In keeping with another aspect of the invention, the modular construction of the light bar makes its assembly easy, quick and error resistant. First, the circuit boards are fabricated in accordance with the types of light beam assemblies to be added. For example, if the light beam assemblies are solid state devices, the fabrication process preferably includes adding the LEDs or other solid state device to the circuit board as part of the fabrication process. With the fabricated boards as a starting point, they are each then populated with two or more light sources in accordance with a customer's requirements (e.g., color, flashing, rotating ). Because each of the

boards includes keys to register the light beam assemblies into a proper position, they are reliably fastened to the circuit boards at the right locations. Then each of the circuit boards is fastened into the housing of the light bar. As the boards are placed into the housing, they are registered to the housing with respect to one of more references, which aligns each of the light sources on the circuit board with a lens in the housing.

**[0016]** Populating the circuit boards with light beam assemblies includes selecting a type of light beam assembly for each station or area of the circuit board in keeping with a customer request. When the boards are fastened to the housing of the light bar to register the light beam assemblies with the lenses of the housing, a single cable is connected between the circuit board and the controller in order to deliver power and control signals to the light beam assemblies.

**[0016.1]** According to a related aspect of the present invention, there is provided a light bar for a vehicle comprising:

a housing of the light bar for mounting to the vehicle such that the housing extends substantially across a roof of the vehicle, the housing (1) having a front and a back that include lenses for transmitting light from an interior of the housing and (2) containing one or more circuit boards each having a planar surface extending between the front and the back;

each of the circuit boards having patterns of keys in its surface that complement patterns of keys in two or more light beam assemblies so as to register the fastening of the two or more light beam assemblies to the circuit board at predetermined positions;

each of the patterns of keys in the circuit board are associated with electrical connections leading to one or more connectors on the circuit board so as to provide an electrical connection between the one or more connectors and one of the two or more light beam assemblies mated to the circuit board at one of the predetermined positions defined by the pattern; and

the housing including components of fasteners complementing components of fasteners in each of the circuit boards such that engagement of the complementing components registers the circuit board to the housing so that the two or more light beam assemblies fastened to the circuit board are automatically aligned with one or more lenses in the housing.

**[0016.2]** According to another aspect of the present invention, there is provided a light bar made by the process of:

fastening two or more emergency lights on a planar surface of a circuit board by matching a pattern of keys on each of the emergency lights to a complementary pattern of keys in the planar surface of the circuit board so as to position the two or more emergency

5a

lights at predetermined locations on the planar surface of the circuit board that (1) enable completion of electrical connections between the emergency lights and the circuit board and (2) position the emergency lights to beam light substantially along the planar surface of the circuit board;

electrically connecting the two or more emergency lights to a cable connector on the circuit board by completing the electrical connections between the two or more emergency lights and the circuit board enabled by the fastening of the two or more emergency lights to the circuit board; and

fastening the circuit board in a housing of the light bar for securing to a surface of an emergency vehicle such that the planar surface of the circuit board extends longitudinally across the housing and the fastening is accomplished by longitudinally aligning complementing patterns of keys in the circuit board and the housing, resulting in the emergency lights being optically aligned with one or more lenses in the housing.

[0016.3] According to another aspect of the present invention, there is provided a light bar for mounting to an emergency vehicle comprising:

a housing dimensioned to extend substantially across the emergency vehicle and having lenses in at least one of a front and a rear of the housing;

one or more circuit boards mounted to the interior of the housing and oriented to have their planar surfaces extending longitudinally between the front and rear of the housing;

each circuit board including conductive traces providing electrical connections between a connector on the circuit board and two or more sites on the circuit board for mounting emergency lights; and

at least two of the sites on each of the circuit boards having keys for mating with complementary keys on the emergency lights in order to fasten the emergency lights at predetermined positions on the circuit board that align the emergency lights with the lenses of the housing and enable electrical connection between the circuit board and the emergency lights.

[0016.4] According to another aspect of the present invention, there is provided an emergency light for a vehicle, comprising:

a housing having lenses for transmitting light from an interior of the housing;

one or more circuit boards within the housing, each circuit board having a planar surface extending toward two or more of the lenses for supporting two or more light beam assemblies such that each assembly is aligned with one of the lenses;

5b

each of the circuit boards having; one or more connectors mounted for electrically communicating with the two or more light beam assemblies by way of electrical connections fabricated on the circuit board;

a first set of patterns of alignment keys for registering the two or more light beam assemblies to the circuit board so that the light beam assemblies are fastened to the circuit board at positions predetermined by the patterns; and

a second set of patterns of alignment keys in the housing for positioning each of the circuit boards within the housing at a predetermined location that automatically aligns the two or more light beam assemblies fastened to each of the circuit boards with the lenses of the housing when the circuit boards are fastened to the housing,

thereby enabling each of the lenses to cooperate with a corresponding aligned light beam assembly to broadcast a light beam alerting observers of the vehicle to an emergency condition.

**[0016.5]** According to another aspect of the present invention, there is provided a process for making an emergency light whose external housing is divided into separable sections and contains light assemblies comprising beam shaping devices that each produce a separate light beam, the process including:

populating a circuit board with two or more of the light assemblies by registering each of the light assemblies with respect to one or more references on the circuit board, which registration properly positions the light assembly for generating a light beam;

fastening each of the light assemblies to the circuit board at the proper position, where the proper position orients the light beam produced by the beam shaping device of the light assembly to be substantially in a direction perpendicular to a normal of a flat surface of the circuit board;

piloting the circuit board to mate with an interior surface of at least one of the sections of the housing by aligning one or more references fixed to the circuit board and one or more references fixed to the housing, which alignment registers each of the light assemblies fastened to the circuit board with a lens in the housing such that each individual light assembly corresponds to an individual lens in the housing;

fastening the circuit board to the interior surface of the housing section; and

mating the sections of the housing so that the circuit boards and the light assemblies are contained within a closed space defined by the interior of the housing.

**[0016.6]** According to another aspect of the present invention, there is provided a self-powered light bar for mounting to a vehicle, the light bar comprising:

an elongated housing for spanning a roof of the vehicle;

5c

emergency lighting mounted within the housing;  
solar cells mated with the housing for providing power to the emergency lighting;  
a storage device also mated with the housing and in communication with the solar cells for storing energy generated by the solar cells when the energy is not being used by the emergency lighting;

a controller mounted within the housing for controlling the emergency lighting and for coordinating the flow of energy to the emergency lighting from the solar cells and the storage device; and

a receiver mounted within the housing for wirelessly communicating with a control head in a passenger compartment of the vehicle.

[0016.7] According to another aspect of the present invention, there is provided a method for retrofitting a vehicle to include an emergency signaling system, the method including:

mounting an emergency signaling system contained in a common housing to the vehicle without any external wiring connecting the housing and the vehicle;

applying energy to emergency lights within the common housing from a source of energy that is mated with the common housing;

providing command signals to a controller in the common housing by way of a wireless connection between the controller and a user interface remote from the common housing; and

operating the emergency lights in response to commands from the controller that are in keeping with the command signals received by way of the wireless connection such that the emergency lights contained by the common housing are operated and controlled without any wiring connecting the emergency lights to sources of energy or control that are external to the common housing.

[0017] While the invention will be described in some detail with reference to preferred and alternative embodiments, these embodiments are intended to be illustrative and limiting the invention to such detail. However, the scope of the claims should not be limited by the preferred embodiments set forth in the examples, but should be given the broadest interpretation consistent with the description as a whole.

5d

## BRIEF DESCRIPTION OF THE SEVERAL VIEWS OF THE DRAWINGS

- [0018] Figure 1 illustrates an emergency vehicle equipped with a light bar incorporating the invention;
- [0019] Figs. 2 through 9 illustrate assembly of the light bar shown in Figure 1 as follows:
- [0020] Fig. 2 illustrates an aluminum extrusion that provides a structural basis for the light bar;
- [0021] Fig. 3 illustrates joining to the extrusion of Fig. 2 a center section of a lower portion of a housing for the light bar;
- [0022] Fig. 4 illustrates joining to the extrusion end sections of the lower portion of the light bar housing that mate with the center section;
- [0023] Fig. 5 illustrates the lower portion of the light bar housing fully assembled on the aluminum extrusion, including an electronic controller;
- [0024] Fig. 5a is a sectional view of the assembled lower portion of the light bar taken along the line 5a-5a in Fig. 5;

LVM 701305

6

[0025] Fig. 6 illustrates populating one of five circuit boards in the light bar with light beam assemblies in keeping with one embodiment of the invention;

[0026] Fig. 6a illustrates an alternative embodiment for the circuit board in Fig. 6 in which an edge of the board is turned at a right angle to orient light emitting diodes (LEDs) mounted in the board such that light beams from the LEDs directly radiate through lenses of the light bar housing without being re-oriented by reflectors as required by the planar board of Fig. 6;

[0027] Fig. 7 illustrates populating the five circuit boards into the assembled lower portion of the light bar housing of Fig. 5 in keeping with one embodiment of the invention;

[0028] Fig. 8 illustrates joining an upper portion of the housing to the assembled lower portion in order to complete the assembly of the light bar;

[0029] Fig. 9 is a schematic diagram illustrating the electrical connections between the controller and the circuit boards in Fig. 8;

[0030] Fig. 10 is a schematic diagram of the controller in Fig. 5;

[0031] Fig. 11 illustrates an alternative embodiment of the invention wherein the five circuit boards in Figs. 2-8 are replaced with a single monolithic circuit board;

[0032] Fig. 12 illustrates a further alternative embodiment in which external power and signaling cables running to the light bar are eliminated by providing one or more power sources resident in the light bar and wireless receiver circuitry for receiving small signal commands from a remote control source; and

[0033] Fig. 13 illustrates still another alternative embodiment in which the circuit board of Fig. 7 is populated with light beam assemblies on both its top and bottom sides.

#### DETAILED DESCRIPTION OF THE INVENTION

[0034] Turning to the drawings and referring first to Fig. 1, an emergency signaling system 11 according to a preferred embodiment of the invention is installed in an exemplary emergency vehicle 13 shown in broken lines. The system 11 includes a plurality of light beam assemblies or signaling devices best shown in Figs. 6 and 7. The emergency signaling system 11 is mounted to a roof 15 of the vehicle 13.

[0035] Emergency signaling systems of the type mounted to the roofs of emergency vehicles are commonly called "light bars" because they are typically shaped as a bar traversing the

*LVM 701305*

7

vehicle's roof. In keeping with this convention, the illustrated emergency signaling system 11 is hereinafter referred to as a "light bar" since it is primarily intended for mounting to the roofs of emergency vehicles such as the roof 15 of the illustrated vehicle 13. However, those skilled in the art will appreciate that the manufacturing technique described hereinafter for the illustrated light bar is applicable to other types of lighting systems such as traffic directional indicators.

[0036] As best shown in Figs. 2-4, the light bar 11 includes a frame 17 formed from an aluminum extrusion supporting a housing 19 (Figs. 1 and 8) containing light beam assemblies and a portion of the circuitry for controlling the assemblies as will be explained more fully hereinafter. The housing 19 forms a protective shell for the light beam assemblies and is mounted to the frame 17 as best shown in Figs. 2-4. The housing 19 comprises three bottom sections 19a, 19b and 19c as best illustrated in Figs. 3 - 5, forming a bottom shell. The bottom shell mates with a top shell 19d (Fig. 8) as best shown in Figs 1 and 8 to substantially seal the interior space of the housing 19. However, access holes are in the bottom shell for allowing cable to be threaded into the interior space and to allow of ventilation of the space. The top and bottom shells of the housing 19 include gaskets (not shown) to help seal the interior of the light bar 11 from the external environment. In this illustrated embodiment, the seals and gaskets are like those in the Arjent™. The top and bottom shells of the housing 19 include gaskets (not shown) to help seal the interior of the light bar 11 from the external environment. In this illustrated embodiment, the seals and gaskets are like those in the Arjent™ light bar. The top and bottom shells are made of a transparent material such as a polycarbonate plastic, which is a conventional material often used for emergency lighting devices such as light bars.

[0037] The external portions of the light bar 11 are illustrated as being substantially the same as a Federal Signal Arjent™ light bar. For example, the light bar 11 mounts to the vehicle 13 by way of a mounting assembly at each end of the frame, which is not illustrated, but is substantially the same as Federal Signal's Arjent™ light bar. Also, well known techniques for electrically and physically sealing the housing 19 are employed and, for the illustrated light bar 11, they are the same as that of the Arjent™ light bar. For example, Fig. 2 illustrates two linear strips 21a and 21b of cushioning material that interface the frame 17 to the sections 19a, 19b and 19c of the bottom shell of the housing 19. Gaskets such as the gaskets 23a and 23b in Fig. 3 provide an effective water seal for the opening 25 in the center of the housing section 19b.

*LVM 701305*

Similar seals (not shown) mate with the end sections 19a and 19c to seal the openings 27 and 29, respectively, in these sections of the housing 19.

[0038] With all three of the lower sections 19a, 19b and 19c in place on the frame 17 as shown in Fig. 5, the gaskets cooperate with the frame 17 to completely seal the lower shell of the housing 19. However, air holes, such as a hole 31 in Fig. 5, are typically formed in one or more sections of the housing to allow for circulation of air. In general, however, the gaskets seal the interior of the lower shell of the housing 19 from water and other ambient conditions of the external environment that might otherwise interfere with the operation for electronics in the light bar 11.

[0039] Although the illustrated embodiment is based on an Arjent™ light bar, many different light bar housings are amenable to being fitted with the invention. Staying with Federal Signal's product line as an example, light bars such as the Raydian™, Jet™, Aerodynamic™, Streethawk™ and Vista™ may also benefit from the invention as well as light bar designs not yet commercialized.

[0040] In keeping with an Arjent™ light bar, the frame 17 is preferably formed by a conventional extrusion process to define a channel 33, best seen in Fig. 5a, for communicating wiring emanating from one of the housing sections 19a, 19b and 19c to other sections. After the housing 19 is secured to the frame 17, the channel 33 is environmentally isolated so that wiring in the channel is protected from ambient conditions.

[0041] In order to form the housing 19 and secure it to the frame 17, the bottom shell of the housing 19 comprising sections 19a, 19b and 19c is secured to the frame 17 by threaded screws or other types of fasteners (not shown) received by pre-drilled pilot holes in the frame. Circuit board assemblies are mounted in the bottom sections 19a, 19b and 19c as explained in detail hereinafter. In this regard, any type of light radiating device (e.g., a LED, halogen, strobe) may be used as the lighting assemblies of the invention. As explained hereinafter in greater detail, an attribute of the light beam assemblies or light sources in keeping with the invention is their ability to be mounted directly to a circuit board.

[0042] Referring to Fig. 1, a control head 35 in a passenger compartment 37 of the vehicle 13 controls the light beam assemblies in the light bar 11. The control head 35 is connected to first and second control units 39 and 41, respectively, in order to communicate control signals to the

*LVM 701305*

light beam assemblies in the light bar 11. The control unit 39 in the illustrated embodiment provides control functions for other emergency signaling apparatus associated with the vehicle 13. For example the control unit 39 may also serve a siren. In vehicles without other emergency signaling apparatus, however, the control unit 39 may be eliminated and the wiring to the light bar may be directly from the control head 35. The operator of the vehicle 13 preferably mounts the control head 35 to the dashboard/instrument panel area 43 of the vehicle just to the right of the steering wheel 45 for easy access. Although the first control unit 39 is shown as mounted in the trunk area of the vehicle 13, it may be mounted elsewhere within the vehicle, depending upon the precise design of the vehicle and the number of other accessories included in the vehicle. For example, control unit 39 may be mounted under the dashboard area 43. The second control unit 41 (shown in Fig. 5) is mounted within the housing 19 of the light bar 11.

[0043] Keystrokes to a keypad 47 incorporated into the control head 35 generate control signals and the control head provides them to the control unit 39 by way of a cable 49, which in turn communicates signals to the control unit 41 within the light bar 11 by way of cable 51. A control system such as Federal Signal's Smart Siren™ system is a suitable example of the illustrated control system.

[0044] From the control unit 41 in the light bar 11, the operation of the light beam assemblies is directly controlled in accordance with signals generated at the control head 35. Installers of the light bar 11 typically strategically place cables 49 and 51 within the interior of the vehicle 13 so they are the least conspicuous and require the least modification of the standard interior features. In this regard, a serial connection between the control head 35 and the control unit 39 effectively minimizes the number of wires comprising the cables 49 and 51. Each of the two cables 49 and 51 includes two data-carrying wires for bi-directional serial communications. Separate cabling from a battery 53 carries power and reference ground wires to the control units 39 and 41, which in turn deliver the power the light assemblies on the circuit boards. In an alternative embodiment illustrated in Fig. 12, the control signals are electromagnetic signals that propagate through the air so that the cables are not needed for controlling the light bar 11. In a further alternative embodiment also illustrated in Fig. 12, the cables 49 and 51 are entirely eliminated by providing one or more power sources in and/or on the light bar 11. These

*LVM 701305*

alternative embodiments will be more completely described in connection with the description of Fig. 12 hereinafter.

**[0045]** Keystrokes to keys on the keypad 47 of the control head 35 initiate operating modes of the light bar 11 that provide different visual or warning patterns. Each of the warning patterns creates an effect that provides a particular degree of warning suitable for one or more specific situations.

**[0046]** In addition to comprising different types of light sources such as LEDs and halogen lights, the light beam assemblies may also be of different types of functionality. For example, some of the light beam assemblies may provide warning functions while others provide non-warning functions such as flooding specific areas with light. For example, the light assemblies may include lighting of steady illumination in single directions, which is commonly labeled a "take down" function. Other lights may serve to illuminate toward the sides of the vehicle 13 and are referred to as "alley lights." All of these different types of light sources and functionality may be among those populating the light bar 13 and activated for operation through the control head 35. Furthermore, the light beam assemblies may include assemblies that rotate or oscillate.

**[0047]** In accordance with one important aspect of the invention, two or more of the light beam assemblies of the light bar 11 are mounted to a common circuit board that fits into the interior space of the light bar in a predetermined way such that the light beam assemblies are in registration with lenses for the light beams generated by the assemblies. Each circuit board is configured to include keys for registering the fastening of the light beam assemblies to the board at a precise location. In turn, each of the circuit boards includes keys for automatically registering or correctly aligning the positioning of the board in the interior space of the light bar. Thus, during the assembly of the light bar, mating the complementary keys in the light assemblies and circuit board causes the light assemblies to be automatically fastened to the board at predetermined desired positions. Each of the circuit boards has two or more areas defined by the keys for mounting light beam assemblies.

**[0048]** Each of the several areas or stations for mounting a light beam assembly on the circuit board may include several alternative patterns of keys, with each pattern matching to one type of light beam assembly. Alternatively, the pattern of the keys at each area or station for mounting a light beam assembly is the same for all types of assemblies. The illustrated

LVM 701305

embodiment of the invention described in detail hereinafter employs this latter approach. Either way, the pattern of the keys ensures that the light beam assemblies are precisely positioned on the circuit board so that when the board is fastened to the housing of the light bar, the light beam assemblies are in an approximate exact position intended for best broadcasting the light as part of the light bar functionality.

[0049] At each area or station of a circuit board for mounting a light beam assembly, the pattern of the keys ensure any type of assembly (e.g., light emitting diode (LED) or halogen light beam assemblies) are mounted at the desired location for each type. The precise location for an LED-based light beam assembly may be different than that of a halogen light beam assembly. If the two different types of assemblies rely on the same pattern of keys for alignment on the board, then the assemblies themselves are configured to ensure the assemblies are positioned properly assume the shared pattern of keys. By providing a pattern of keys, the assembly process maintains the automatic alignment of the light beam assemblies while at the same time allow for customization of the light bar. For example, for a circuit board that has two areas or stations of keys and two types of assemblies that can be mated to the pattern(s) at the are/station, the board can be configured four different ways as shown in the table below.

	Light Beam Assembly in First Area	Light Beam Assembly in Second Area
1	first type	first type
2	first type	second type
3	second type	second type
4	second type	first type

[0050] The light beam assemblies are fastened to the circuit board with any type of conventional fasteners. In the illustrated embodiment, the fasteners are screws, but they may be other types of fasteners such as snap-on fasteners. The fasteners may also function as the keys for properly registering the light beam assemblies to the circuit board. For example, a pattern of pilot holes in the circuit board complements a pattern of pilot holes in one type of the light beam assemblies such that the holes of the two patterns align in a vertical registration when the light beam assembly is properly positioned on the circuit board. Then the aligned pilot holes receive fasteners to secure or fasten the light beam assembly in a predetermined position on the board that thereby automatically registers the light beam assembly into proper alignment with a lens in the housing 19 of the light bar 11 when the circuit board is mounted to the interior of the light

*LVM 701305*

12

bar. Instead of the keys for automatically aligning the light beam assemblies to the circuit board being patterns of aligned pilot holes for fasteners, the keys may be patterns of complementary posts and pilot holes and one or more mating and aligned pilot holes that receive fasteners to secure the assembly to the circuit board. From the forgoing, those skilled in the art will appreciate there are many other types of keys for precisely aligning the light beam assemblies on the circuit board that may either also function as fasteners or cooperate with fasteners to secure the light beam assemblies in the precise position on the circuit board defined by the registration of the keys.

**[0051]** Once the circuit boards have been populated with light beam assemblies of the appropriate type, they are each fastened to the interior of the light bar 11. In keeping with the invention, the circuit boards are keyed to the interior space of the housing 19 such that each of the boards fits in a predetermined position within the housing. The predetermined position aligns the light beam assembly with lens in the housing 19 for receiving light beams generated by the assemblies.

**[0052]** Preferably, the circuit board is of a composition that maintains its structural and electrical integrity over the ambient conditions of the light bar 11. In this regard, the light bar 11 is directly exposed to weather conditions in the area it is placed in service, which can include both hot and cold weather extremes. If the circuit board cannot tolerate these conditions, significant warping of its otherwise relatively large planar surface may cause electrical connections to fail and misdirection of the light beams. Also, some of the types of the light beam assemblies have attributes that may impose additional requirements on the circuit board. For example, some light beam assemblies produce significant amounts of heat, making the heat sinking capacity of the circuit board an important characteristic. In addition, the printed circuit board is a structural component in the light bar assembly in that it provides a platform for supporting the light beam assemblies.

**[0053]** Given the foregoing considerations and requirements, suitable circuit boards for the invention presently available include but are not limited to the following: Fiberglass, phenolic, aluminum (e.g., Berquist boards), steel and ceramic printed circuit board materials. Regardless of the specific composition, the boards need to be structurally robust to environmental conditions that include temperature cycling over an expected wide range that the light bar will be exposed to

LVM 701305

wherever it is operating. Some specific examples of aluminum products and sources of suitable boards are ELPOR™ by ECA Electronics of Leavenworth, Kansas and Anotherm™ of TT Electronics PLC of Clive House 12-18, Queens Road, Weybridge Surrey KT13 9XB, England. Moreover, conventional fiberglass-based circuit boards may also provide a basic build block for a suitable board. Multi-layered fiberglass boards by M-Wave™ of Bensenville, Illinois can provide the necessary structural strength and they can be fabricated to have the desired thermal properties by incorporating large ground and power planes into the board and multiple “pass throughs” or “vias.” Turning to Fig. 6, an exemplary embodiment of a circuit board 55 in keeping with the invention includes four areas or stations 57a, 57b, 57c and 57d for fastening light beam assemblies to the board. Each of the areas 57a-57d includes keys for aligning one of the two types of light beam assemblies 59 and 61 illustrated in Fig. 6. The pattern of keys at each of the areas 57a-57d in the illustrated embodiment includes three pilot holes 63a, 63b and 63c in the circuit board 55. In the illustrated embodiment, the pattern of the keys is the same for both types of light beam assemblies 67 and 85.

**[0054]** The circuit board illustrated in Fig. 6 includes two of the light beam assemblies 67 and one of the assemblies 85. The following description refers to just one of the assemblies 67 since they are identical. Those readers skilled in the art will appreciate that the description applies to both light assemblies 67 and, more generally, as many light assemblies 67 that may populate the circuit board.

**[0055]** The light beam assembly 67 includes six light emitting diodes (LEDs) collectively identified as number 65 in Fig. 6 and a reflector 68. The reflector 68 of the light assembly 67 redirects light from a vertically traveling beam emanating from the LEDs to a horizontally traveling beam. The LEDs 65 are laid down on the circuit board as part of the board's fabrication process. In this regard, the circuit board includes conductive paths leading from a connector 77 mounted along an edge of an opening 79 in the board 55. As discussed in further detail hereinafter, the connector 77 mates with a connector 81 of a cable 83 that has an opposing end connected to the control board 41. The cable 83 carries power and control signals to the board 55. Electrical lead lines in the circuit board carry power and control signals to the electronic components (e.g., drivers) and LEDs 65 and to all other types of light beam assemblies on the circuit board.

*LVM 701305*

14

[0056] In the illustrated embodiment, the second type of light beam assembly 85 is a halogen light beam assembly. Lead lines on the circuit board from the connector 77 carry power and control signals to a connector 87. The connector 87 is configured to mate with the connector 89 that provides the ends of wiring 91 to the halogen light beam assembly 85. The halogen light beam assembly comprises a halogen bulb 93 and a reflector 95. The heat sinking properties of the circuit board 55 serve to cool the environment surrounding the halogen light, which includes the LEDs 65 in the upper right hand part of the circuit board. By managing the thermal conditions surrounding the halogen light 93, the LEDs are maintained at a thermal condition that allows them to operate efficiently. Exposure to high heat would otherwise cause the performance of the LEDs to deteriorate.

[0057] Both types of light beam assemblies in Fig. 6 are associated with keys for precisely positioning the light beam assemblies on the circuit board 55. The keys in the circuit board 55 comprise a pattern of pilot holes for each area or station of the board for receiving a light beam assembly. The pattern of pilot holes is the same for all types of light beam assemblies, but that need be true as previously mentioned. Each light beam assembly could mate to a different pattern of keys in an area. In the illustrated embodiment, three holes at each area of the board 55 for receiving a light beam assembly register an assembly to a precise position on the board. Because the circuit board 55 is substantially rectangular and fits into the housing 19 at an area where the housing is curved, the two patterns of keys on each of the two opposing ends of the board 55 are offset from one another by a distance that accommodates the curvature of the housing 19. In this manner, the light beam assemblies are maintained at a desired proximate position with respect to the interior surface of the housing 19 despite mismatch between the curved interior surface of the housing 19 and the rectangular shape of the circuit board 55.

[0058] The reflector 68 includes a pattern of keys that complements the pattern of the pilot holes 63a, 63b and 63c in the circuit board 55. Mating the keys of the reflector 68 to the pilot holes 63a, 63b and 63c in the circuit board 55 automatically aligns or registers the location of the reflector at a location for properly reflecting and redirecting the light from the LEDs 65.

[0059] In the illustrated embodiment, the keys in the reflector 68 comprise two posts and a pilot hole as best seen in the reflector in the upper right of the circuit board 55. The pilot hole 69b aligns with pilot hole 63b in the circuit board 55 and receives a fastener in the form of a

*LVM 701305*

15

screw 71 to fasten the reflector to the board. Posts 69a and 69c (the former is partially obscured in the illustration of the reflector 68 in the upper right of Fig. 6) mate with pilot holes 63a and 63c, respectively, of the circuit board 55. To further assist in the correct alignment of the reflector 68 on the circuit board 55 and to provide additional structural integrity, the reflector 68 includes tabs 73a and 73b at the lower extents of the reflector's sides, which are best seen in the reflector in the lower left of circuit board 55 in Fig. 6. The tabs 73a and 73b of the reflector 68 in the upper right corner of the circuit board 55 mate with complementary slots 75a and 75b, respectively, in the circuit board. However, because the reflector 68 in the lower left of the circuit board 55 in Fig. 6 is set forward on the board to accommodate the curvature of the housing 19, the forward ends of that reflector's sides including the tabs 73a and 73b extend beyond the circuit board. Therefore, there are no slots in the circuit board for receiving the tabs of this reflector.

[0060] In the illustrated embodiment of the invention, the halogen light beam assembly 85 in Fig. 6 incorporates a pattern of keys substantially the same as those of the reflector 68 for the LED light beam assembly 67. Therefore, the circuit board 55 has a complementary pattern of keys for the halogen light beam assembly that is substantially the same for both types of light beam assemblies 67 and 85. However, because of the configuration of the halogen light beam assembly 85, the middle of the three pilot holes in the pattern is not used for registering the assembly into its proper position on the circuit board 55. Specifically, the pilot holes 101a and 101c in the base plate 103 of the halogen light beam assembly 85 align with the pilot holes 63a and 63c, respectively, in the circuit board 55 as illustrated. Screws 61 serve as fasteners to secure the halogen light beam assembly 85 to the circuit board 55 at the precise position defined by the registration of the pilot holes 101a and 101b with the pilot holes 63a and 63c, respectively.

[0061] Moreover, the halogen light beam assembly 85 is illustrated as a stationary light, but those skilled in the art will appreciate that the assembly may also be an oscillating assembly. Furthermore, additional types of lights other than LED and halogen based assemblies are appropriate for mounting to the circuit board in a keyed fashion in keeping with the invention. For example, strobe light assemblies may be mounted to the circuit board if properly keyed for precise and automatic registration.

*LVM 701305*

[0062] Although the circuit board 55 in Fig. 6 includes four areas or stations 57a, 57b, 57c and 57d for each receiving a type of light beam assembly, only three of the four areas are shown as being populated. In this regard, the template-like design of the circuit board 55 allows for customized population of the light beam assemblies onto the board 55 while the keys at each position assure that the assemblies are properly positioned. As a further aid in the assembly or manufacturing process, a label such as the label 97 in Fig. 6 includes custom configuration instructions for the board 55. For example, during the process of assembling the light bar 11, a factory worker reads the instructions on the label 97, which provides information describing the type and details (e.g., color) of the light beam assemblies for each of the areas or stations 57a, 57b, 57c and 57d of the board. The board comes to the factory worker with the LEDs 65 already mounted to the board since in the illustrated embodiment they have been added to the board during the board's fabrication process. However, those skilled in the art will appreciate that the LEDs 65 can be added as part of the assembly process in appropriate circumstances. In any event, the design of the circuit board allows at once full flexibility to customize the lights and colors of the light bar 11 while assuring that the assembly process proceeds quickly and reliably because of the keys that automatically cause the light beam assemblies to be secured by the factory worker to the areas 57a, 57b, 57c and 57d such that they are in proper registration when the board is secured to the housing 19. Wiring from each of the light beam assemblies is either already laid down as part of the printed circuit board (e.g., the LED-based light assembly) or a connector is fabricated into the board to transition a cable of the assembly to lead lines on the circuit board (e.g., the halogen lamp light beam assemblies).

[0063] A cushion strip 99 protects the top of the reflector 68 from being damaged by repeated contact with the interior surface of the housing 19. In the illustrated embodiment, the top of the reflector 68 is physically very close to the interior surface of the housing 19 when the circuit board 55 is mounted to the housing. The cushion strip 99 helps ensure movement from vibration resulting in the top of the reflecting touching the surface of the interior surface of the housing does not result in damage to the reflector. In order to provide mechanical stress relief for the connectors 77 and 87, support brackets 105 and 107 are keyed to slots 109 and 111, respectively, and fastened to the circuit board 55 by screws 113. A flange area of the brackets 105 and 107 cover the tops of the connectors 77 and 87, respectively, to support the connectors

*LVM 701305*

when they are torqued by coupling and decoupling the mating connectors 91 and 89, respectively. Although there is only one halogen light beam assembly 85 in the illustrated embodiment of the circuit board 55 in Fig. 6, the board is configured for supporting two types of assemblies and, therefore, since the area 57d is not configured for an LED light beam assembly 67, a connector 115 of the same type as connector 87 is mounted to the circuit board to support the addition of a halogen light beam assembly at area 57d if required. Like connector 87, connector 115 is associated with a bracket 117 that provides stress relief. The bracket 117 is fastened to the circuit board 55 by a screw 119, but it could be any type of fastener.

**[0064]** The circuit board 55 is preferably installed into the light bar housing 19 upside down with respect to its orientation illustrated in Fig. 6. This orientation of the circuit board enables the light beam assemblies 67 and 85 to be properly aligned with lenses in the lower shell of the housing 19. The lenses in the housing may be distinct from the surrounding area of the housing 19 or simply be a continuation of the same material comprising the housing and of substantially a continuous contour with the surrounding area, assuming the material has acceptable optical properties for successfully transmitting the light beams from the light beam assemblies. If the lenses are distinct, they may be Fresnel lenses or other types of conventional optical lenses or reflectors. The lenses may either comprise material that is the same or different from the material comprising the housing 19. In the illustrated embodiment, the lower shell of the housing 19 comprises material of good optical properties and, therefore, the lenses are simply continuations of the areas surrounding the lenses and visually are not distinct from other parts of the lower shell.

**[0065]** Each of the circuit boards is fastened to the lower shell of the housing 19 in the illustrated embodiment. However, for different types of housings, the circuit boards may be fastened to the tops or sides and a combination of top, bottom and sides. In any event, either the fasteners themselves or other alignment devices serve as keys to register the placement of the circuit boards into the interior of the shell of the housing 19 so that the light beam assemblies 67 and 85 are automatically aligned with the lenses of the housing 19. The fasteners can be any of several types of connectors. For example, they can be snap on type connectors or they may be screws as shown in the illustrated embodiment in Fig. 7. The keys in the circuit boards and in the housing 19 ensure proper lateral alignment of the circuit boards within the interior space of

*LVM 701305*

the housing 19. For proper vertical alignment, the illustrated embodiment relies on the proper height dimensioning of posts molded into the lower shell of the housing 19.

[0066] Referring again to the circuit board 55 in Fig. 6, pilot holes 119a, 119b, 119c and 119d comprise a key for the registering the circuit board to section 19c of the lower shell of the housing 19 as best illustrated in Fig. 7. Pilot holes in vertical posts 121a, 121b, 121c and 121d in the housing section 19c in Fig. 7 serve as a pattern of keys that complements the pattern of keys formed by pilot holes 119a, 119b, 119c and 119d in the circuit board 55 to ensure proper placement of the circuit board in the housing section and the registration of light beam assemblies with the housing's lenses. Two of the lenses are identified in the illustration of Fig. 7 and numbered 123a and 123b. When the circuit board is mounted to section 19c of the housing 19 the light beam assemblies 67 and 85 are automatically registered in place with the lenses 123a and 123b, respectively.

[0067] In the illustrated embodiment, stand offs 125a, 125b, 125c and 125d mate with the pilot holes 119a, 119b, 119c and 119d in order to vertically align the circuit board 55. However, those skilled in the art will appreciate that the stand offs are dictated only by the details of the mechanical construction of the illustrated embodiment and are not a necessary aspect of the invention.

[0068] Although the circuit board 55 is illustrated in Fig. 6 as being substantially planar in its shape, it may also be fabricated to have angled sections for structural support and/or for orienting light sources to more effectively broadcast their light beams. For example, Fig. 6a illustrates how the circuit board 55 may be fabricated to be angled at least at one of its ends 56 to orient the LEDs 65 and their light beams for directly radiating in a horizontal direction without requiring the reflect 68 in the board 55 of Fig. 6.

[0069] In the illustrated embodiment as shown in Fig. 7, each of the end sections 19a and 19c of the housing 19 receive two circuit boards. A total of five circuit boards (including board 55) similar in construction to circuit board 55 are secured to the sections 19a, 19b and 19c of the housing 19 in order to provide a full array of light beam assemblies in the housing. The shapes of the circuit boards in one of the end sections 19a and 19c are mirror images of the shapes of the boards in the other section. Thus, circuit board 55 illustrated and discussed in detail in connection with Fig. 6 is mounted into section 19a of the housing 19. A circuit board 127 of the

*LVM 701305*

19

same size and shape fits into a mirrored position in section 19c of the housing 19. Similarly, a circuit board 129 is mounted into the end section 19a and a circuit board 131 of the same size and shape fits into a mirrored position in section 19c. A fifth circuit board 133 is mounted into the center section 19b of the housing 19.

[0070] Each of the circuit boards 55, 127, 129, 131 and 133 is grounded to the frame 17 that extends through the sections 19a, 19b and 19c through the section's openings 27, 25 and 29, respectively. Because the openings do not extend under the end circuit boards 129 and 131, each of these circuit boards includes a ground wire 135 extending from the board to the frame 17.

[0071] In order to hold the circuit boards 55, 127, 129, 131 and 133 in the housing and ensure their proper alignment for registering the light beam assemblies to the lenses of the housing, screws 137 shown in Fig. 7 are threaded into the pilot holes formed by aligning the pilot holes of the circuit boards with the complementary pilot holes in the vertical posts of the housing sections 19a, 19b and 19c. Specifically, each of the circuit boards 127, 129, 131 and 133 is configured similarly to the circuit board 55 described in detail above. Just as the screws 137 fasten the circuit board 55 to secure and properly align the circuit board in section 19a of the housing 19, they provide the same function for the other circuit boards 127, 129, 131 and 133.

[0072] After each of the circuit boards 55, 127, 129, 131 and 133 has been populated with light beam assemblies in a manner in keeping with the population of the circuit board 55 as described above, the boards are registered to the housing 19 using the patterns of keys comprising the pilot holes and then secured by fasteners such as the screws 137. In addition to the mechanical assembly of the light bar 11, cables connect each of the boards 55, 127, 129, 131 and 133 to the controller 41 in order to bring power and control signals to each board. For example, in Fig. 6 the connector 27 is mated to the end connector 81 of the cable 83. As best seen in Fig. 7, the cable 83 connects the circuit board 55 to a connector 141 (See Fig. 5) mounted to the circuit board of the controller 41. Each of the other circuit boards 127, 129, 131 and 133 also is associated with a cable that connects the board to the controller 41 in substantially the same way as described in detail for circuit board 55.

[0073] Once the boards are mechanically and electrically secured to the lower sections 19a, 19b and 19c of the housing 19, the upper section 19d of the housing comprising an upper shell of the housing is fastened to the lower shell comprising the assembled lower sections as best

*LVM 701305*

illustrated in Fig. 8. Cabling from a power source such as the battery 53 and control signals from the control head 35 are threaded through a hole 145 to the controller 41, where the cables connect to a connector 147 (See Fig. 5).

[0074] Referring to Fig. 9, each of the circuit boards 127, 129, 131 and 133 includes a connector substantially like the connector 77 of circuit board 55 in Fig. 6 that mates to a connector of a cable communicating power and control signals to the circuit board. As best seen in Figs. 5 and 7, the circuit board of the controller 41 includes a connector for coupling to a cable from each of the circuit boards 55, 127, 129, 131 and 133 that are populated with light beam assemblies. Thus, the circuit board for the controller 41 includes five connectors for coupling to five cables from the five circuit boards 55, 127, 129, 131 and 133. A sixth connector 147 on the circuit board of the controller 41 connects to a cable from the control unit 39 that delivers power and control signals to the light bar 11.

[0075] Referring to Fig. 10, the controller 41 interprets a serial stream of input data generated by keystrokes to the keyboard 47 of the control head 35. The serial data includes information identifying one of several available flash patterns for one or more of the light beam assemblies. The flash patterns are stored as data in a memory in the controller 41.

[0076] The RS485 transceiver sends and receives balanced, digital signals through the RJ45 connector. The transceiver takes the difference of the received signals and passes the result to the main microcontroller and the Signalmaster™ microcontroller in the form of a single ended digital data stream. The Signalmaster™ microcontroller is a product of Federal Signal Corporation of Oak Brook, Illinois.

[0077] Based upon the data received in the stream, each of the microcontrollers in Fig. 10 acts based upon embedded software. Examples of functions performed by the microcontroller include sending serial flash pattern streams to the shift registers to create a preprogrammed flash pattern. Other examples include powering down the light bar's circuitry to minimize parasitic current when the system is not being used.

[0078] The shift registers store the pattern data for each clock cycle and output a digital control signal to the LED drive circuitry. This control signal tells the LED circuitry to activate the LEDs or keep them in an OFF state. Combinations of these digital control signal streams

*LVM 701305*

going to multiple heads/LED drive circuits create the random or synchronized visual light patterns commonly seen in the patterns created by light bars.

[0079] In the illustrated embodiment of Figs. 2-8, five discrete circuit boards are assembled into the housing 19 in order to position and secure all of the light beam assemblies. As an alternative, Fig. 11 illustrates the same housing 19 except a single monolithic circuit board 151 is secured to the lower shell comprising sections 19a, 19b and 19c. Like the five discrete circuit boards illustrated in Figs. 2-8, the single circuit board 151 of Fig. 11 includes a pattern of keys that mate to a pattern of keys in the interior of the bottom shell of the housing 19 so that the light beam assemblies populating the circuit board precisely register with the lenses of the housing 19. Like the embodiment of Figs. 2-8, the keys in the embodiment of Fig. 11 comprise pilot holes that align with pilot holes in the sections 19a, 19b and 19c of the housing 19. Fasteners, shown as screws 153 in Fig. 11, secure the circuit board 151 in the housing and maintain the proper registration of the board provided when the pilot holes are aligned.

[0080] In a further alternative embodiment, power to the circuit boards in Figs. 2-8 or the single board in Fig. 11 is provided by power sources local to the light bar 11, thereby eliminating the need to provide a power cable from the vehicle 13 to the light bar 11. For example, as illustrated in Fig. 12, one or both of a fuel cell 155 and an array of solar cells 157 generate sufficient energy to power all of the electronics in the light bar 11. A suitable hydrogen fuel cell is Nab II available from Jadoo Power Systems of Folsom, California and suitable solar cells are available from BP Solar of Warrenville, Illinois. The fuel cell 155 is mounted to an interior space of the light bar 11, whereas the array of solar cells 157 is mounted to an external surface of the light bar such as the top section 19d of the housing 19 in Figs. 1, 8 and 11. Of course, both the fuel cell 155 and the array of solar cells 157 can be located elsewhere and even on the vehicle 13 itself.

[0081] There may be times when the solar cells 157 produce energy that is not immediately used by the light bar 11. In those situations, an energy storage device 158 stores the energy so that it can be later used by the light bar. For example, the solar cells may produce more energy than used by the light bar during a sunny day. That unused energy is stored in the storage device 158 and used when the solar cell is unable to provide sufficient power such as in the evening or during cloudy day conditions. Of course, the fuel cell 155 can also supplement the solar cells,

*LVM 701305*

but it cannot be easily charged with the unused energy from the solar cells 157, thus requiring a storage device 158 such as a battery or the previously identified ultra capacitor. In order to orchestrate the storage of energy and the delivery of the energy to the light bar from among the three sources of the fuel cell 155, the array of solar cells and the storage device, an appropriate power supply circuit switches among or blends the energy from these sources. The power supply circuit (not shown) can be made part of the controller 41 or constructed separately.

**[0082]** As a further alternative, the light bar 11 can be made completely wireless by providing a transceiver 159 (Fig. 12) with the controller 41 so that the control signal from the control head 35 are delivered to the controller 41 as electromagnetic signals 161, which are preferably short range radio frequency signals. The control head 35 provides its control signals to a transceiver 163, which broadcasts the control signals as low power RF signals to the transceiver 159. For example, the electromagnetic link 161 between the controller 41 and the control head 35 may be in accordance with the well known Bluetooth protocol, which is maintained by the Institute of Electrical and Electronic Engineers (IEEE) as its 802.15.1 standard. However, those familiar with low power RF communications will appreciate that many other communications protocols can be used, including other IEEE standards. Those skilled in the art of short distance wireless communications will appreciate that a receiver may be substituted for the transceiver 159 if the communications path is one way between the control head 35 and the controller 41. Likewise, a transmitter may be substituted for the transceiver 163.

**[0083]** As a still further alternative embodiment, depending on the configuration of the interior space of the light bar 11, the circuit boards 55, 127, 129, 131 and 133 may be populated on both sides with light beam assemblies as suggested by the illustration of the circuit board 55' in Fig. 13. In Fig. 13, the circuit board 55' is substantially like the circuit board 55 in Fig. 6 except circuit board 55' has been fabricated to include LEDs in all of the four areas or stations 57a, 57b, 57c and 57d. In contrast, the board 55 in Fig. 6 is fabricated to support LED light beam assemblies 67 in two of the four areas or stations and halogen light beam assemblies 85 in the other two areas or stations for mounting light beam assemblies. In Fig. 6, the underside of the circuit board 55 is simple a ground plane. The underside of the circuit board 55', however, is fabricated to provide four additional areas or stations, each shown in Fig. 13 to support a LED light beam assembly 67 (only three are visible). Of course, in keeping with the invention, each

of the eight areas of the circuit board 55' can be fabricated to support any type of light beam assembly. The light beam assemblies are mounted to the circuit board 55' and precisely registered on the board in the same way as described above in connection with the board 55. Likewise, the board 55 is secure into the light bar housing in keeping with the approach taken in the embodiment in Figs. 2-8, which results in the light beam assemblies being positioned in precise registration with the lenses of the housing.

[0084] In addition to the alternative configuration of the circuit boards themselves as illustrated in Figs. 6a and 13, the physical relationship among the circuit boards may be other than the co-planar relationship of the illustrated embodiment. For example, the circuit boards may be stacked to provide multiple levels of lights in the light bar. Still other modifications to the configuration of each circuit board and their relative orientation will be appreciated by those skilled the art of emergency signaling devices such as light bars.

[0085] Cancelled.

[0086] The use of the terms "a" and "an" and "the" and similar referents in the context of describing the invention (especially in the context of the following claims) are to be construed to cover both the singular and the plural, unless otherwise indicated herein or clearly contradicted by context. The terms "comprising," "having," "including," and "containing" are to be construed as open-ended terms (i.e., meaning "including, but not limited to,") unless otherwise noted. Recitation of ranges of values herein are merely intended to serve as a shorthand method of referring individually to each separate value falling within the range, unless otherwise indicated herein, and each separate value is incorporated into the specification as if it were individually recited herein. All methods described herein can be performed in any suitable order unless otherwise indicated herein or otherwise clearly contradicted by context. The use of any and all examples, or exemplary language (e.g., "such as") provided herein, is intended merely to better illuminate the invention and does not pose a limitation on the scope of the invention unless otherwise claimed. No language in the specification should be construed as indicating any non-claimed element as essential to the practice of the invention.

*LVM 701305*

24

[0087] Preferred embodiments of this invention are described herein, including the best mode known to the inventors for carrying out the invention. Variations of those preferred embodiments may become apparent to those of ordinary skill in the art upon reading the foregoing description. The inventors expect skilled artisans to employ such variations as appropriate, and the inventors intend for the invention to be practiced otherwise than as specifically described herein. Accordingly, this invention includes all modifications and equivalents of the subject matter recited in the claims appended hereto as permitted by applicable law. Moreover, any combination of the above-described elements in all possible variations thereof is encompassed by the invention unless otherwise indicated herein or otherwise clearly contradicted by context.

The embodiments of the invention in which an exclusive property or privilege is claimed are defined as follows:

1. An emergency light for a vehicle, comprising:
  - a housing having lenses for transmitting light from an interior of the housing;
  - one or more circuit boards within the housing, each circuit board having a planar surface extending toward two or more of the lenses for supporting two or more light beam assemblies such that each assembly is aligned with one of the lenses;
  - each of the circuit boards having; one or more connectors mounted for electrically communicating with the two or more light beam assemblies by way of electrical connections fabricated on the circuit board;
  - a first set of patterns of alignment keys for registering the two or more light beam assemblies to the circuit board so that the light beam assemblies are fastened to the circuit board at positions predetermined by the patterns; and
  - a second set of patterns of alignment keys in the housing for positioning each of the circuit boards within the housing at a predetermined location that automatically aligns the two or more light beam assemblies fastened to each of the circuit boards with the lenses of the housing when the circuit boards are fastened to the housing,
  - thereby enabling each of the lenses to cooperate with a corresponding aligned light beam assembly to broadcast a light beam alerting observers of the vehicle to an emergency condition.
  
2. The emergency light of claim 1, including
  - an energy source for all energy consuming devices within the housing,
  - light generating devices that are either associated with or part of the two or more light beam assemblies,
  - where the energy source and the housing are mated such that the energy consuming devices operate without requiring electrical wiring from the housing to an electrical system for the vehicle.

3. The emergency light of claim 2, wherein the energy source includes solar cells that convert solar energy to electrical energy and provide the electrical energy to (a) the energy consuming devices and (b) to an energy storage device within the housing when all of the electrical energy generated by the solar cells is not required by the energy consuming devices.
4. The emergency light of claim 3, wherein the light generating devices are light emitting diodes (LEDs) mounted to the one or more circuit boards.
5. The emergency light of claim 1, wherein the light beam assemblies include means for shaping light from light generating devices into the light beams.
6. The emergency light of claim 1, including a receiver within the housing for wireless communication with a user interface located in a passenger compartment of the vehicle.
7. The emergency light of claim 1, including:
  - an energy source for energy consuming devices within the housing, including light generating devices either associated with or part of the light beam assemblies,
    - where the energy source is mated with the housing such that the energy consuming devices operate without requiring wiring between the housing and an electrical system for the vehicle; and
  - a receiver within the housing for wireless communication with a user interface located in a passenger compartment of the vehicle, enabling the energy consuming devices to be controlled without requiring wiring between the housing and the user interface.
8. The emergency light of claim 1, wherein the housing is elongated to extend across a roof of a vehicle such that the emergency light is a light bar for mounting to a roof of a vehicle.

9. The emergency light of claim 1, wherein the alignment keys in the circuit boards for the first and second sets of patterns are holes in the circuit boards.
10. The emergency light of claim 1, wherein at least one of the light beam assemblies is a beam shaping device whose predetermined position on the circuit board optically aligns the beam shaping device with a source of light supported on the circuit board.
11. The emergency light of claim 1, wherein the predetermined position on the circuit board includes at first and second patterns of the first set of patterns with each of the first and second patterns complementing a pattern of alignment keys for a different type of light beam assembly, such that light beam assemblies of different types may be alternatively fastened to the circuit board at the predetermined position.
12. The emergency light of claim 1, wherein the one or more circuit boards are thermally conductive circuit boards that both communicate control signals to the one or more light beam assemblies and sink heat generated by the assemblies.
13. The emergency light of claim 1, wherein the one or more circuit boards are two or more circuit boards each connected to another by a wiring harness.
14. The emergency light of claim 1, wherein light emitting diodes (LEDs) are mounted directly to at least one of the one or more circuit boards and cooperate with a beam shaping device comprising one of the light beam assemblies to generate the light beam.
15. The emergency light of claim 1, wherein the one or more circuit boards is at least two circuit boards mounted in the housing to be substantially side-by-side and co-planar.
16. The emergency light of claim 1, wherein the one or more circuit boards includes a ground plane that divides an interior of the housing into two electrically isolated spaces when the circuit boards are attached to the housing, with each of the ground plane effectively

shielding one of the spaces from any electromagnetic disturbance caused by operation of devices in the other space.

17. A process for making an emergency light whose external housing is divided into separable sections and contains light assemblies comprising beam shaping devices that each produce a separate light beam, the process including:

populating a circuit board with two or more of the light assemblies by registering each of the light assemblies with respect to one or more references on the circuit board, which registration properly positions the light assembly for generating a light beam;

fastening each of the light assemblies to the circuit board at the proper position, where the proper position orients the light beam produced by the beam shaping device of the light assembly to be substantially in a direction perpendicular to a normal of a flat surface of the circuit board;

piloting the circuit board to mate with an interior surface of at least one of the sections of the housing by aligning one or more references fixed to the circuit board and one or more references fixed to the housing, which alignment registers each of the light assemblies fastened to the circuit board with a lens in the housing such that each individual light assembly corresponds to an individual lens in the housing;

fastening the circuit board to the interior surface of the housing section; and

mating the sections of the housing so that the circuit boards and the light assemblies are contained within a closed space defined by the interior of the housing.

18. The process of claim 17, wherein populating the light assemblies includes selecting each light assembly from a group of different types of light sources, where the types include LEDs, halogen lamps, high intensity discharge (HID) lamps, lasers, strobe lamps, incandescent lamps and light engines.

19. The process of claim 17, including

populating another circuit board with two or more light assemblies by registering each of the light assemblies with respect to one or more references on the circuit board and

then fastening the light assembly to the circuit board at a proper position determined by the one or more references;

placing said another circuit board in the housing section; and,

connecting a wiring harness between the said another circuit board and the circuit board.

20. The process of claim 19, including placing the circuit board and the said another circuit board in the housing section such that the flat section of the circuit board is substantially coplanar with a flat section of said another circuit board.

21. The process of claim 17, wherein the proper position of at least one of the light assemblies optically aligns the beam shaping device of the assembly to light emitting diodes (LEDs) supported on the circuit board such that the LEDs and the beam shaping device cooperate to create the light beam.

22. The process of claim 17, including adding a wireless receiver within the housing for receiving remotely generated commands controlling the two or more light sources.

23. The process of claim 17, including physically attaching an energy source to the emergency light for providing energy to all energy consuming devices within the housing, including the light assemblies.

24. The process of claim 17, wherein the emergency light is a light bar.

1/12

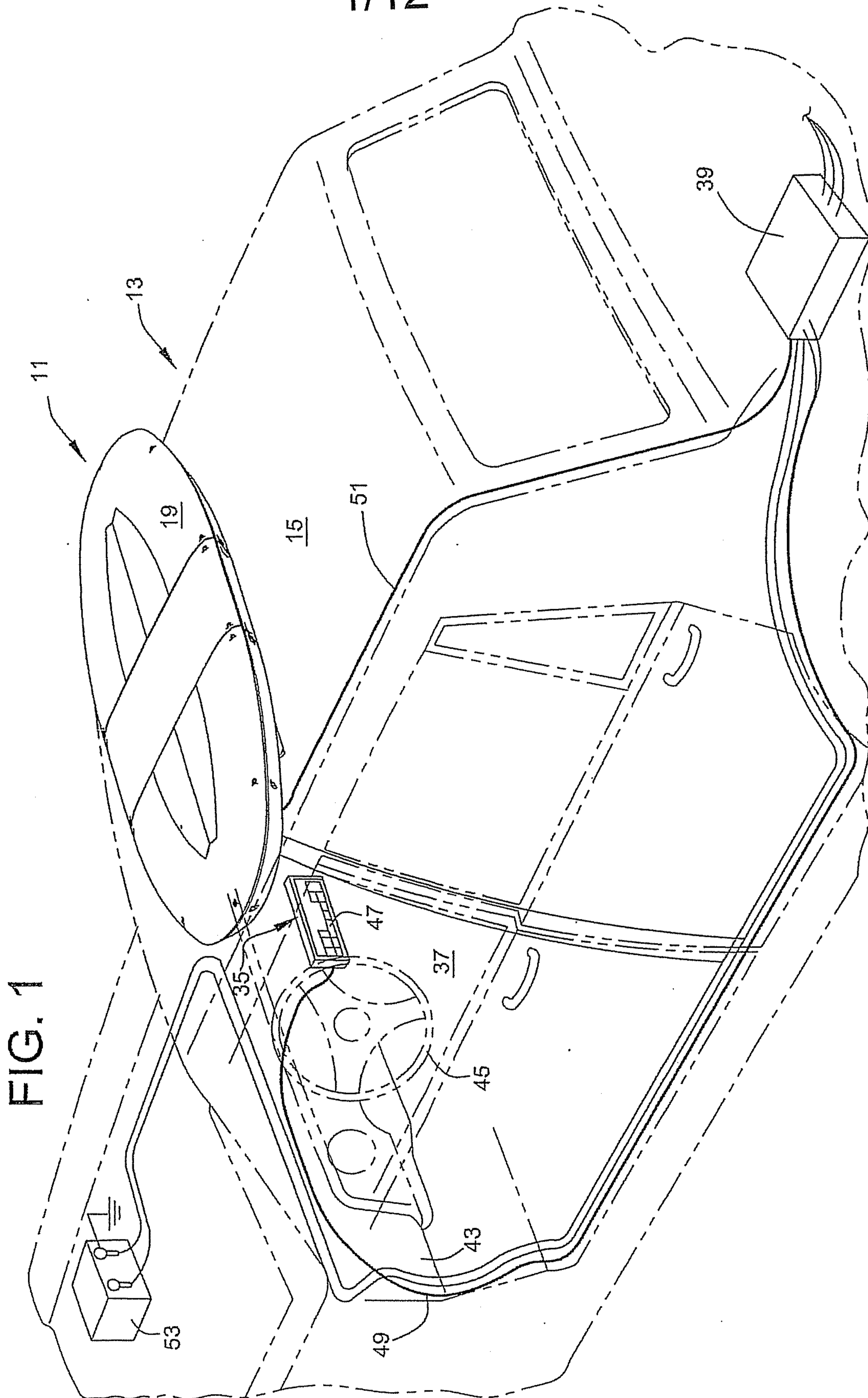

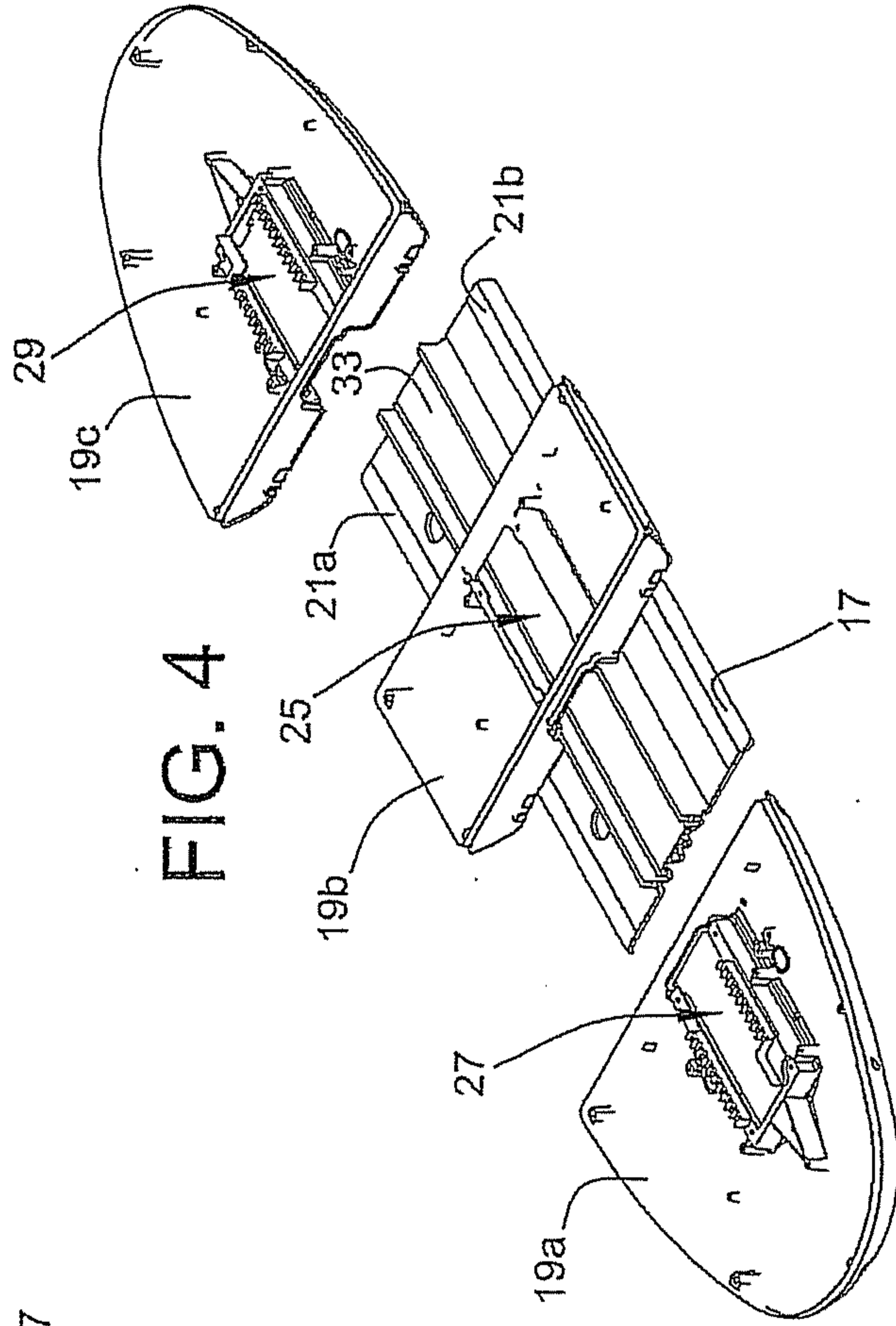
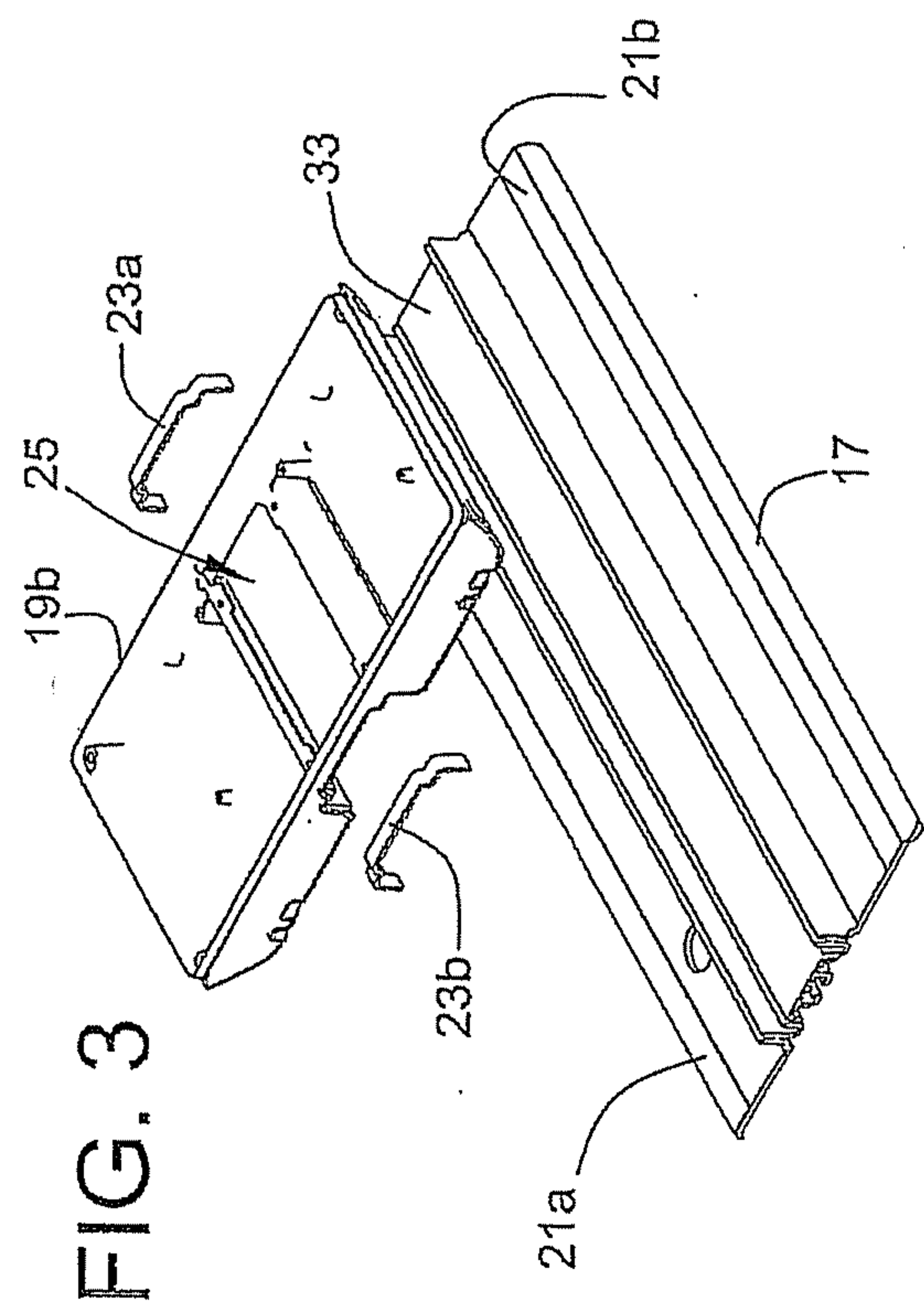
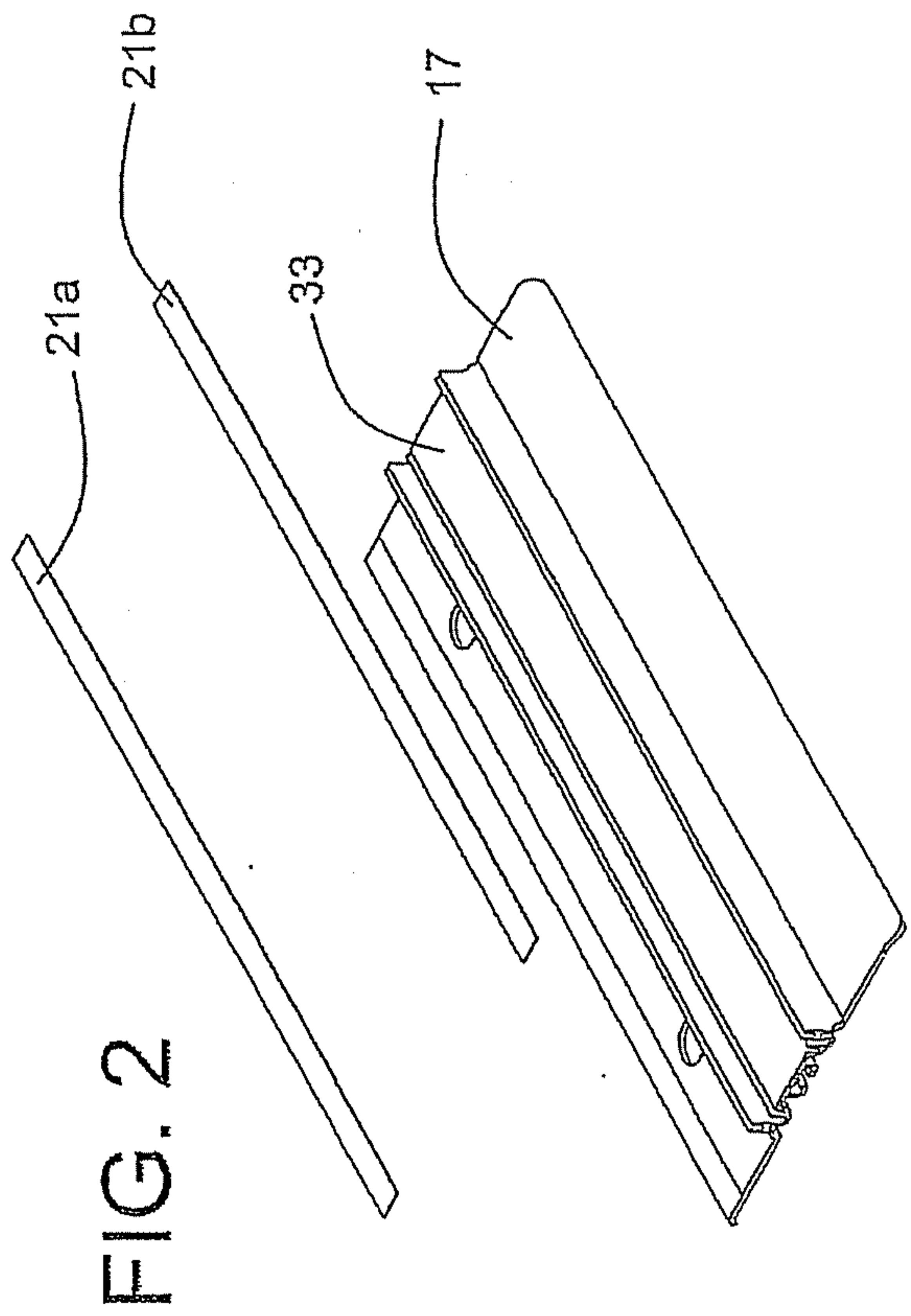

3/12

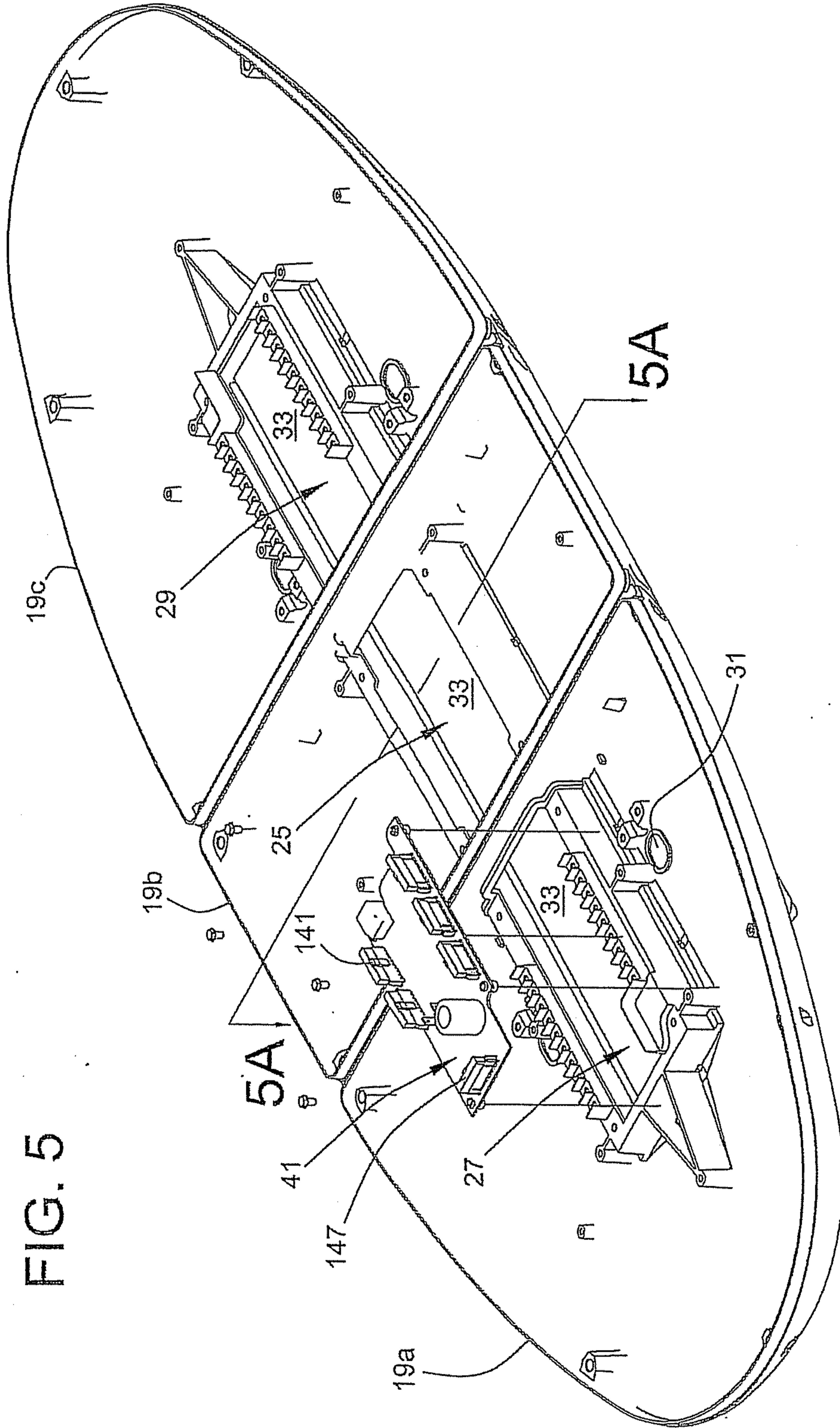
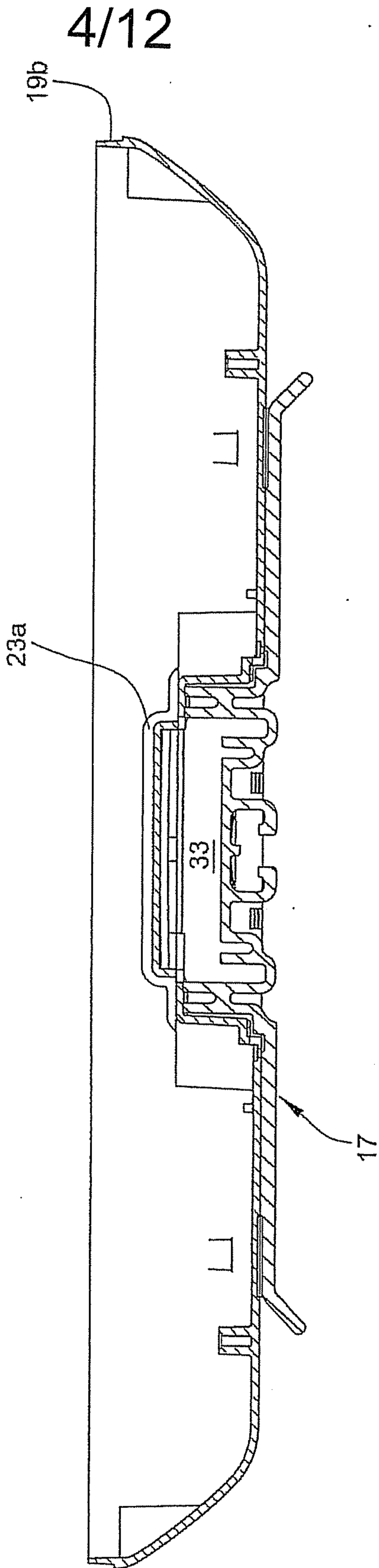

FIG. 5

FIG. 5A





6/12

FIG. 7

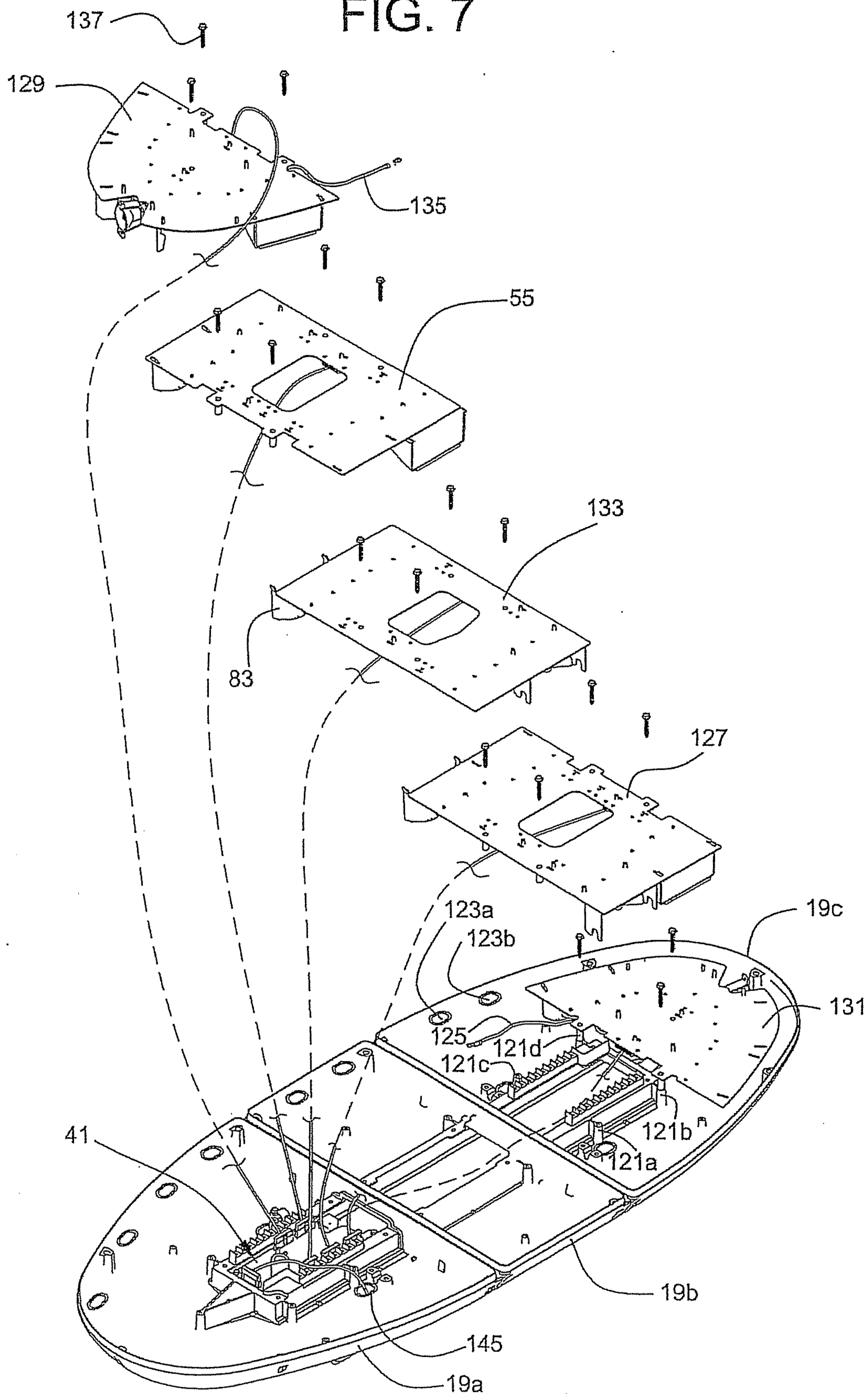

7/12

FIG. 8

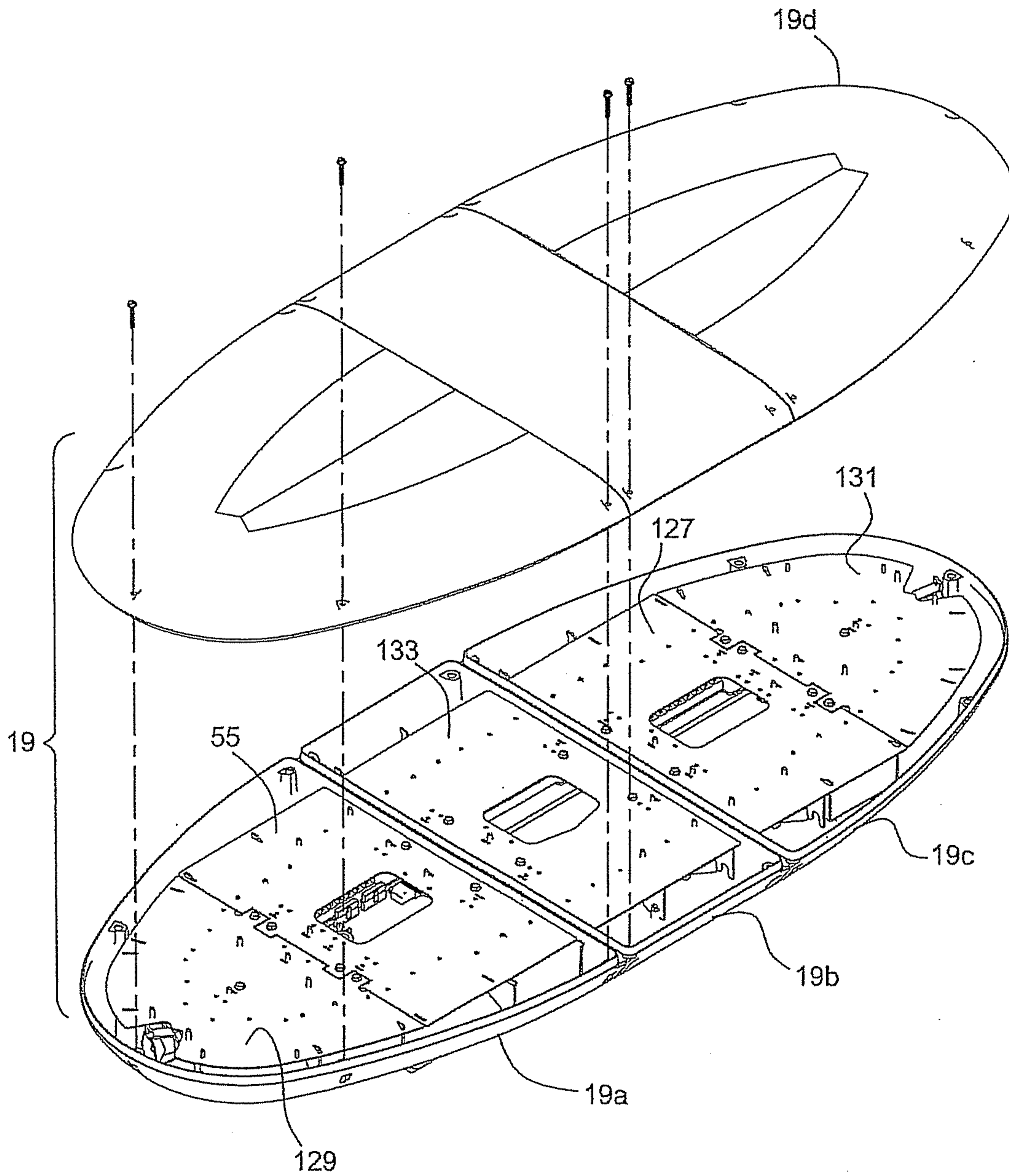

8/12

FIG. 9

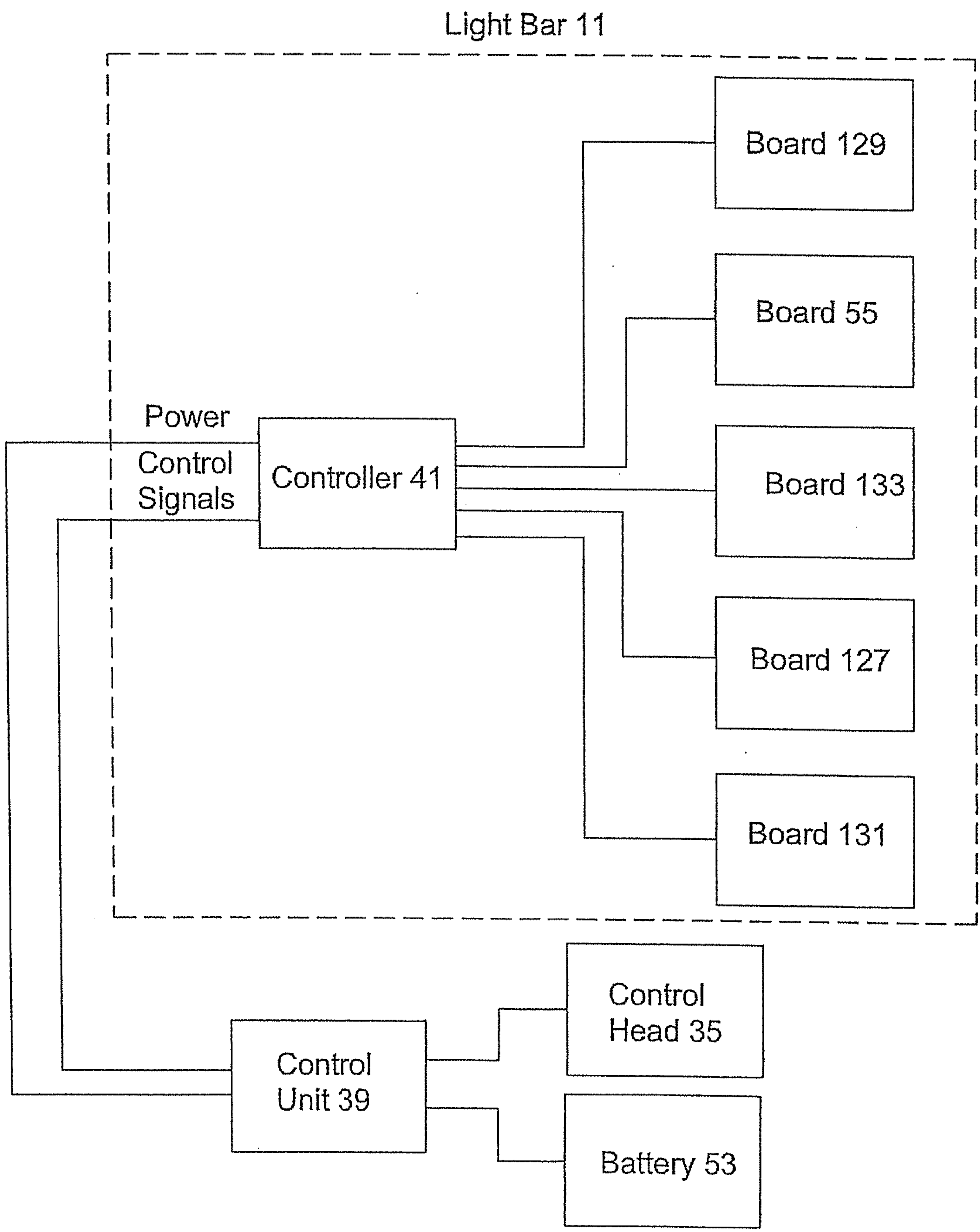

9/12

FIG. 10

CONTROLLER 41

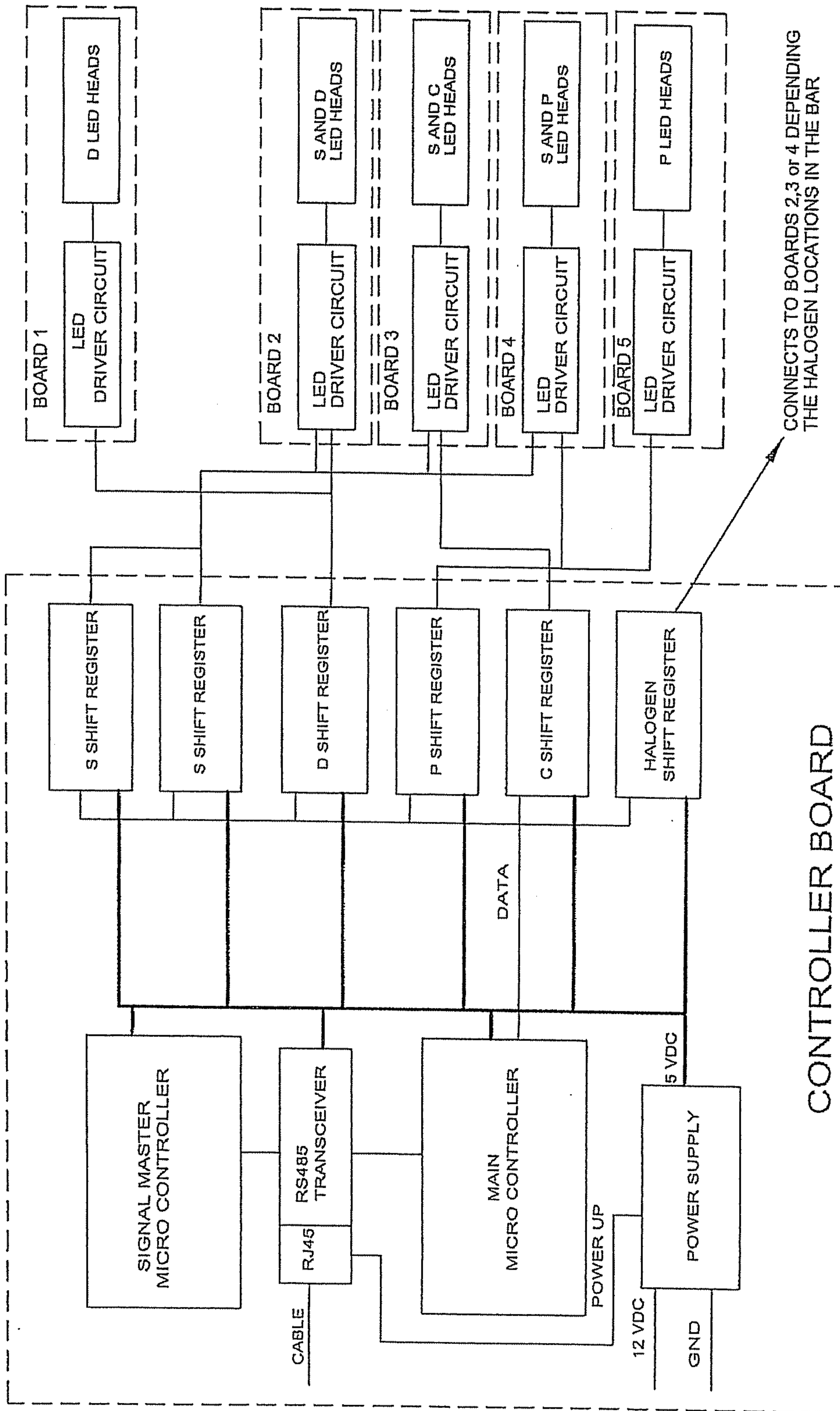

CONTROLLER BOARD



11/12

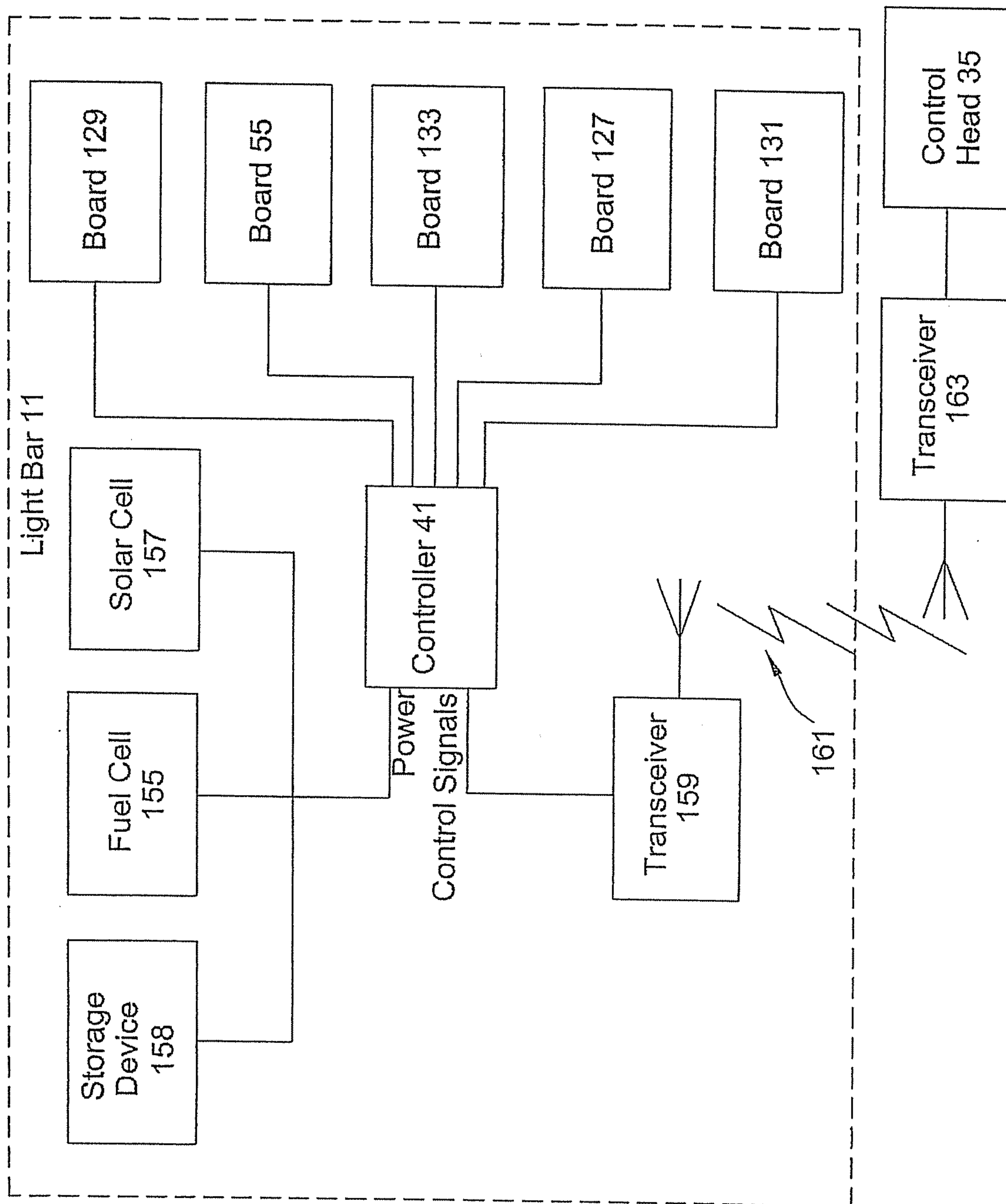

FIG. 12



