

(No Model.)

W. L. KEENE.
BICYCLE LANTERN.

No. 533,849.

Patented Feb. 5, 1895.

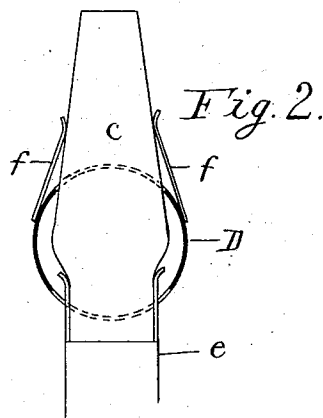
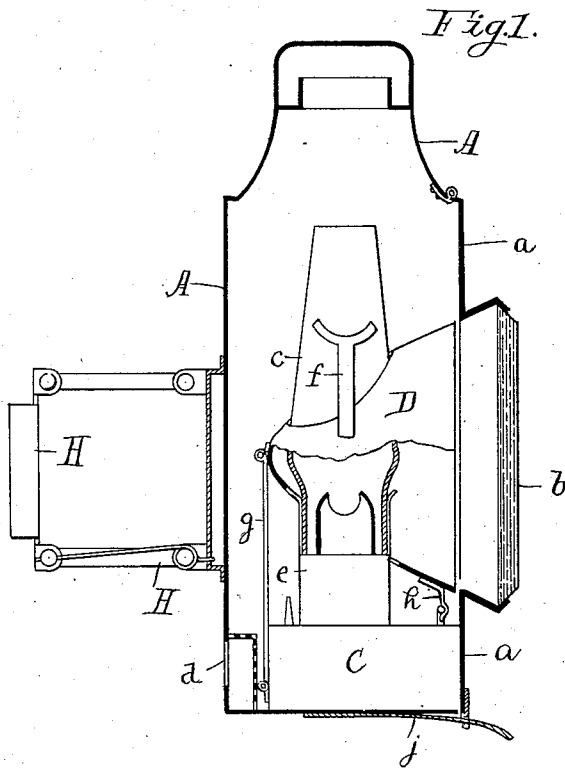

Witnesses:
E. Dyer, Secretary
C. L. Harewood

Inventor:
William L. Keene
by S. W. Bates
his atty.

UNITED STATES PATENT OFFICE.

WILLIAM L. KEENE, OF WATERTVILLE, MAINE, ASSIGNOR OF TWO-THIRDS
TO MARK GALLERT AND WARREN F. BROWN, OF SAME PLACE.

BICYCLE-LANTERN.

SPECIFICATION forming part of Letters Patent No. 533,849, dated February 5, 1895.

Application filed August 10, 1894. Serial No. 519,939. (No model.)

To all whom it may concern:

Be it known that I, WILLIAM L. KEENE, a citizen of the United States, residing at Waterville, in the county of Kennebec and State of Maine, have invented certain new and useful Improvements in Bicycle-Lanterns; and I hereby declare the following to be a full, clear, and exact description of the invention, such as will enable others skilled in the art to which it appertains to make and use the same.

My invention relates to a lantern for bicycles and particularly to the construction of a lantern in which is used the parabolic reflector, this form of lantern being recognized as the most effective form of head light.

The chief difficulty in adapting the parabolic head light to lanterns of small size has always been the fact that a cylindrical chimney was used for the lamp on account of the ease with which it could be handled in connection with the reflector and this involved the use of an Argand burner which produced so much heat that the upper part of the lantern was liable to be melted.

In my present invention I have adapted the ordinary straight burner with its bulging chimney to a lantern having a parabolic reflector and I have devised simple and effective means for handling the chimney and removing it from the lamp without inserting the hand in the reflector. Moreover, in ordinary head lights the chimney is manipulated from inside of the reflector while with small bicycle lanterns this cannot be done but the chimney must be handled from outside the reflector.

In my lantern as I prefer to construct it, I run the chimney up through the reflector in the usual manner and I connect the rear end of the reflector with the lamp by means of a hinged connection which allows it to be tilted backward so that the chimney may be removed. The forward portion of the reflector is secured to the lamp by a latch which holds it ordinarily in position but allows it to be released and turned backward.

I illustrate my invention by means of the accompanying drawings, in which—

Figure 1 is a sectional view extending from front to rear, and Fig. 2 is a part sectional view at right angles to that of Fig. 1.

A represents the casing or outside of the

lantern with its hinged front *a* which is secured at the bottom by means of a latch *j*. The front *a* is provided with a glass bull's eye *b*, which is here shown as made of plain glass.

At the rear of the lantern is a yielding support *H* of any desired construction by which the lantern is attached to the head of the bicycle. Air is admitted at the bottom of the lantern through an aperture *d* and discharged at the top in the usual manner. The lamp *C* is adapted to be slid into place from the front of the lantern and it is provided with an ordinary straight burner *e* as herein shown and a bulging chimney *c* of common construction. The chimney *c* passes through openings in the parabolic reflector *D* the lower opening being sufficiently large to allow the largest portion of the chimney to pass. The upper portion of the chimney is supported by a spring *f* on each side, the lower end of each spring being secured to the reflector.

The reflector is supported in such a manner that it can be tilted backward for the purpose of removing the chimney.

As here shown I pivot a link *g* to the rear end of the reflector the lower end of said link being hinged or pivoted to the back side of the lamp in such a manner that it cannot tilt forward from a vertical position but it is free to tilt backward.

The forward end of the reflector is secured in its ordinary or normal position by means of a latch *h* which connects it with the top of the lamp.

Having thus described the construction of my lantern, the operation thereof will be readily understood.

When it is desired to remove the lamp chimney for lighting the lamp or for any other purpose, the latch *h* is released and the reflector is tilted backward and at the same time it is moved bodily backward lifting the chimney from the burner the combined motion on the two pivots rendering it an easy matter to free the reflector from the burner. Having done this, the chimney may be readily drawn out through the lower opening in the reflector or the lamp may be lighted without entirely removing the chimney.

It will be seen that this construction enables me to make use of a straight burner with its bulging chimney and so avoid the

heat which would be generated by an Argand burner.

So far as I am aware no lantern with a parabolic reflector has ever been in general use for bicycles and it is not necessary to point out the well known efficiency of this class of lanterns in order to explain the advantages of my invention over others in use. The lantern gives a powerful light which enables the bicyclist to ride with nearly as much safety in the darkest night as in the day time.

I claim—

1. The herein described bicycle lantern consisting of a casing, a lamp therein, a chimney for said lamp, a parabolic reflector having apertures through which said chimney passes, a link pivoted to the rear portion of the reflector and to the lamp and a latch connecting

the forward end of said reflector with said lamp.

2. The herein described bicycle lantern consisting of a casing, a lamp therein, a chimney for said lamp, a parabolic reflector having apertures through which said chimney passes, a link pivoted to the rear portion of the said reflector by its upper end and to the rear portion of the lamp by its lower end in such a manner that it can tilt backward but not forward and a latch connecting the forward end of said reflector with said lamp.

In witness whereof I have hereunto set my hand in the presence of two witnesses.

WILLIAM L. KEENE.

In presence of—

E. F. WEBB,

MARK GALLERT.