

F. M. CARROLL.  
 PRINTING MECHANISM FOR CASH REGISTERS.  
 APPLICATION FILED MAR. 31, 1915.

1,245,191.

Patented Nov. 6, 1917.  
 10 SHEETS—SHEET 1.

FIG. 1.

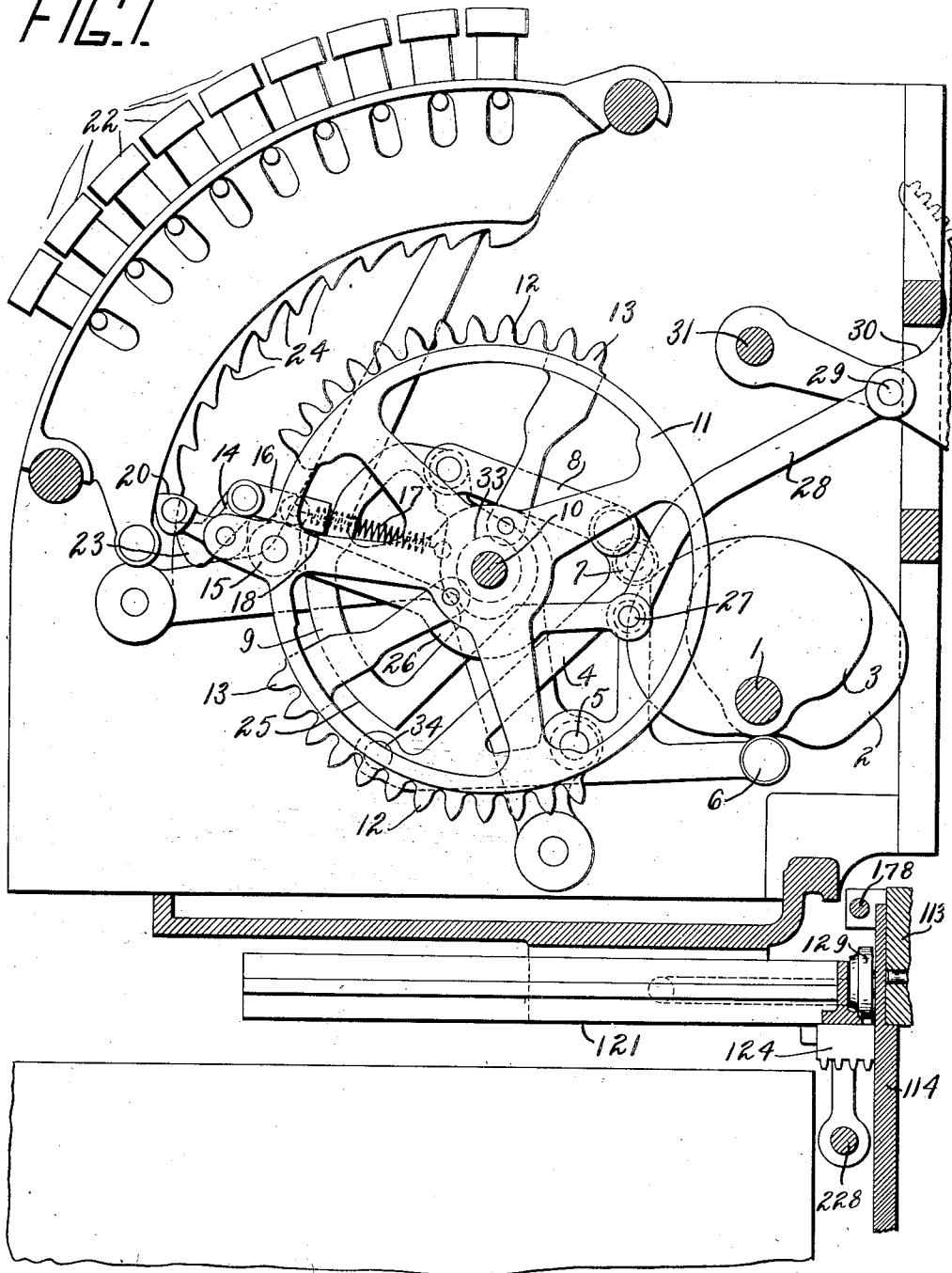

Witnesses  
 H. F. Sadgobury  
 P. J. Linn

Inventor  
 Fred M. Carroll  
 by Release  
 Earl Beust  
 Attorneys

F. M. CARROLL.  
 PRINTING MECHANISM FOR CASH REGISTERS.  
 APPLICATION FILED MAR. 31, 1915.

1,245,191.

Patented Nov. 6, 1917.

10 SHEETS—SHEET 2.

FIG. 2.

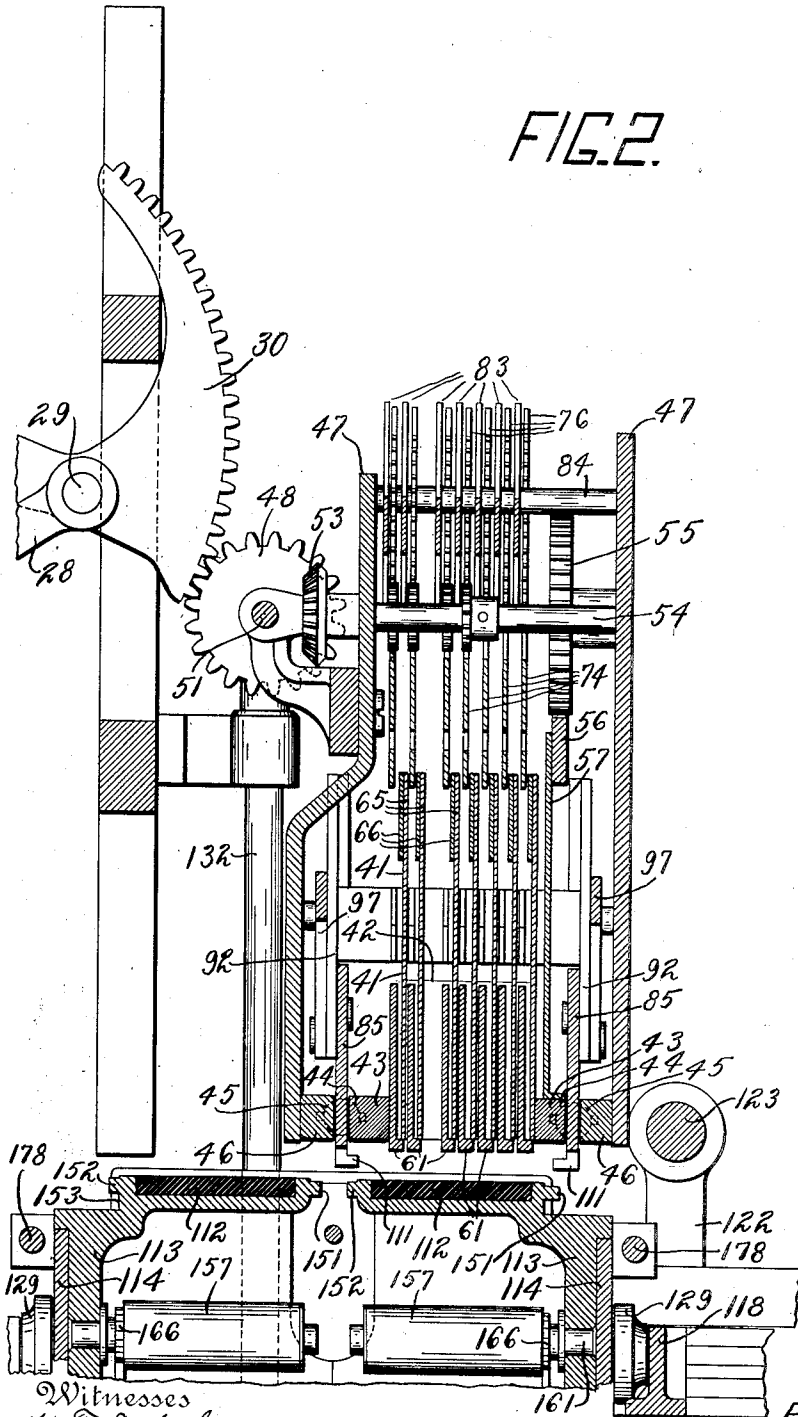

Witnesses  
 H. F. Sadgerbury

*H. F. Sadgerbury*

Inventor  
 Fred M. Carroll  
 by *R. Carlson*  
 Carl Beust  
 Attorneys

F. M. CARROLL.  
 PRINTING MECHANISM FOR CASH REGISTERS.  
 APPLICATION FILED MAR. 31, 1915.

1,245,191.

Patented Nov. 6, 1917.  
 10 SHEETS—SHEET 3.

FIG. 3.

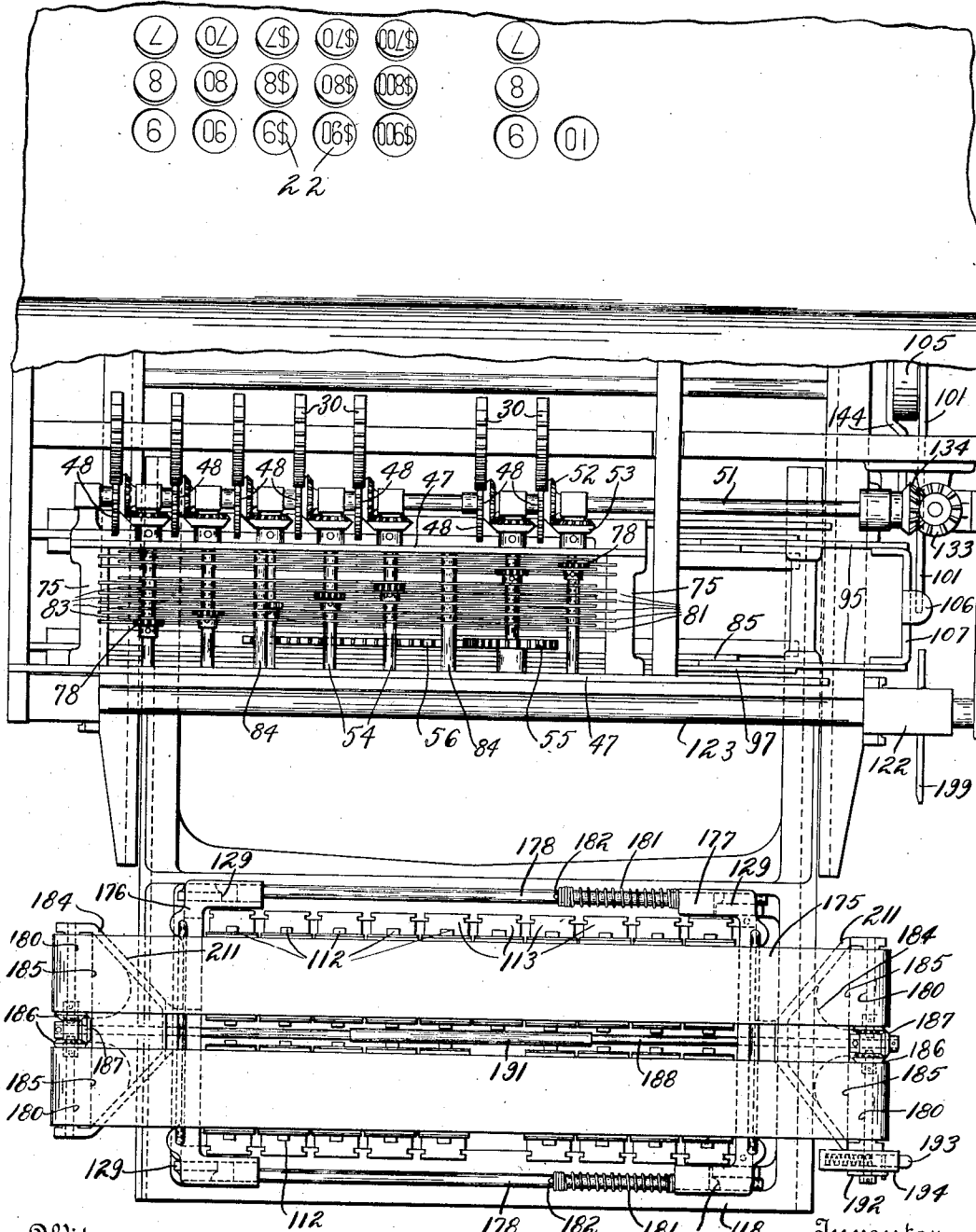

Witnesses  
*H. F. Sadgshury*  
*E. J. Liven*

Inventor  
*Fred M. Carroll*  
 by *R. B. Dore*  
*Earl Beust*  
 Attorneys

F. M. CARROLL.  
 PRINTING MECHANISM FOR CASH REGISTERS.  
 APPLICATION FILED MAR. 31, 1915.

1,245,191.

Patented Nov. 6, 1917.  
 10 SHEETS—SHEET 4.

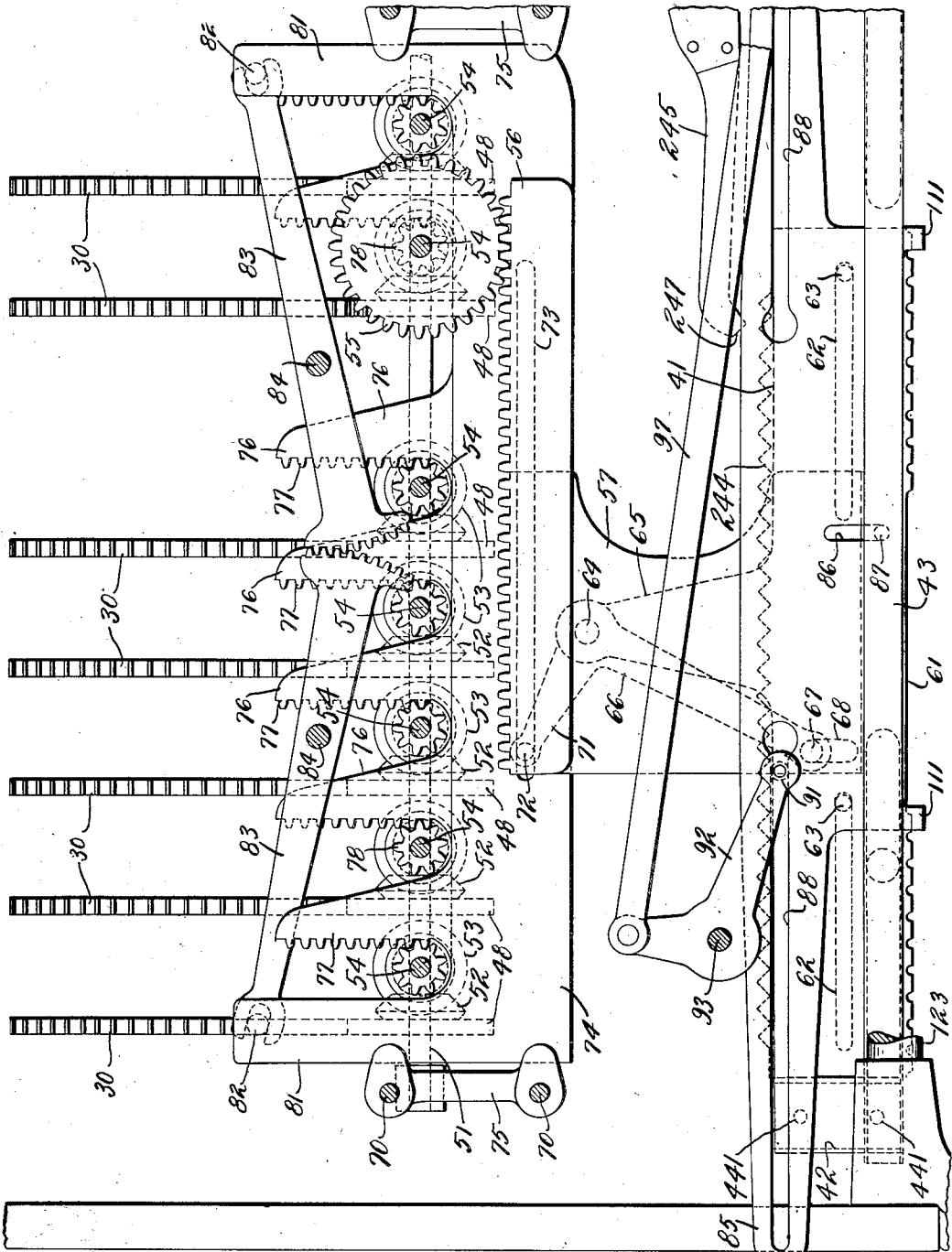

Witnesses  
*H. F. Sadgubury*  
*E. J. Givon*

FIG. 4.

Inventor  
*Fred M. Carroll*  
 by *R. C. Bess*  
*Earl Beust*  
 Attorneys



1,245,191.

Patented Nov. 6, 1917  
10 SHEETS—SHEET 6.

FIG. 6.

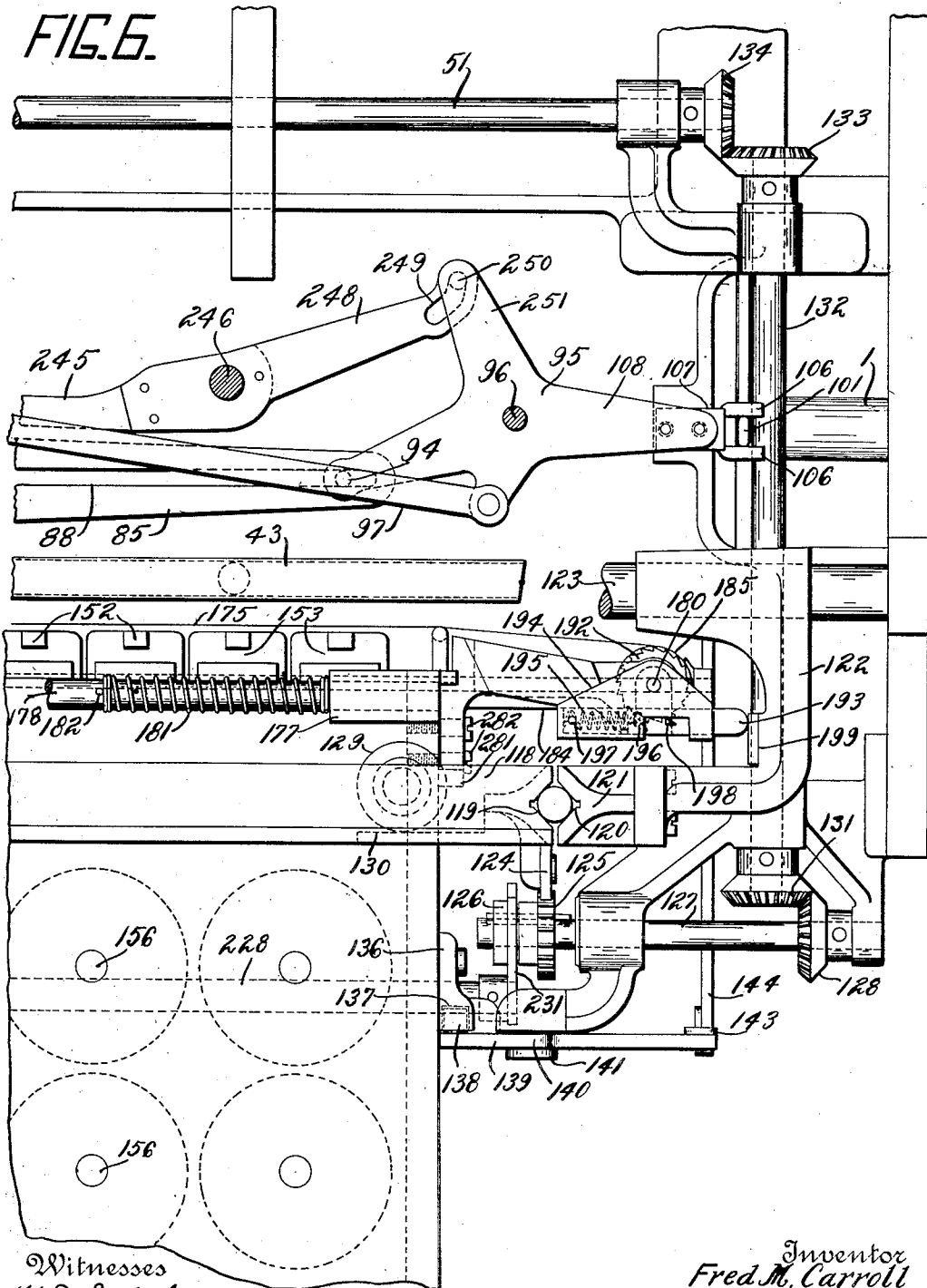

Witnesses  
H. F. Judgbury  
E. D. Linn

Inventor  
Fred M. Carroll  
by Charles  
Heal Beust  
Attorneys

1,245,191.

Patented Nov. 6, 1917.

10 SHEETS—SHEET 7.

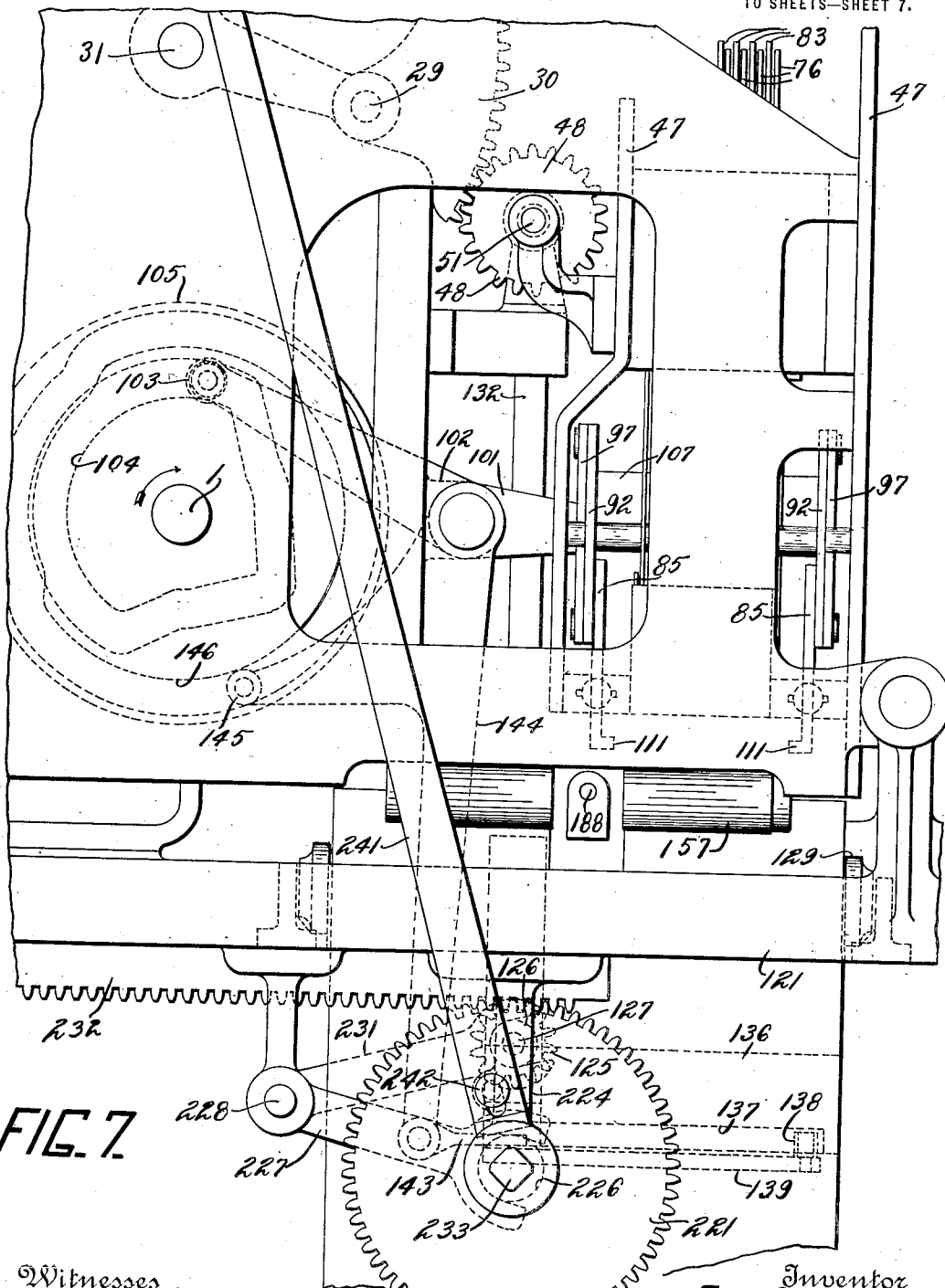
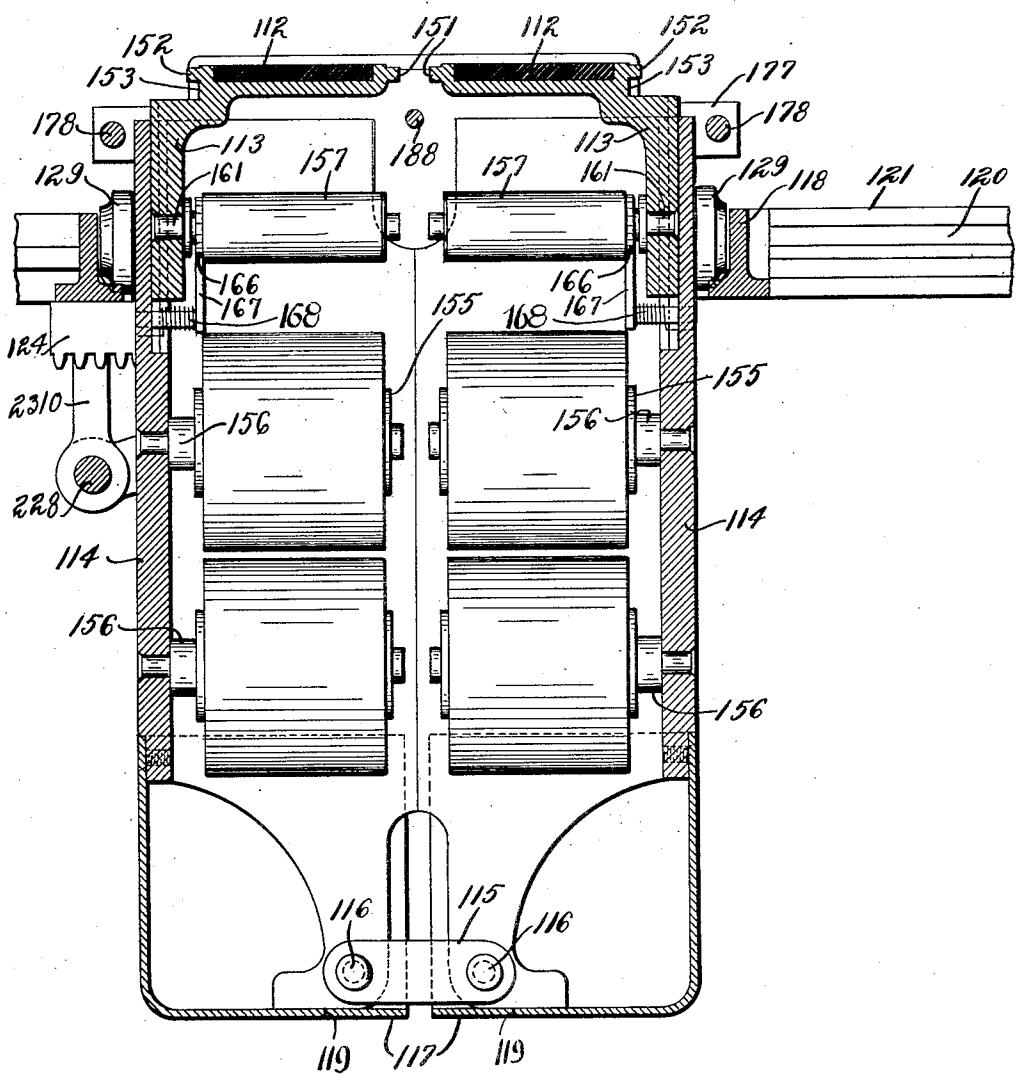

FIG. 7

Witnesses  
 H. F. Sadgebury  
 O. L. Linn

Inventor  
 Fred M. Carroll  
 by R. C. Glass  
 Earl Beust  
 Attorneys

FIG. 8.



Witnesses  
H. F. Sadsbury  
C. R. Liven

Inventor  
Fred M. Carroll  
by R. B. Glass  
Earl Beust  
Attorneys

F. M. CARROLL.  
 PRINTING MECHANISM FOR CASH REGISTERS.  
 APPLICATION FILED MAR. 31, 1915.

1,245,191.

Patented Nov. 6, 1917.  
 10 SHEETS—SHEET 9.

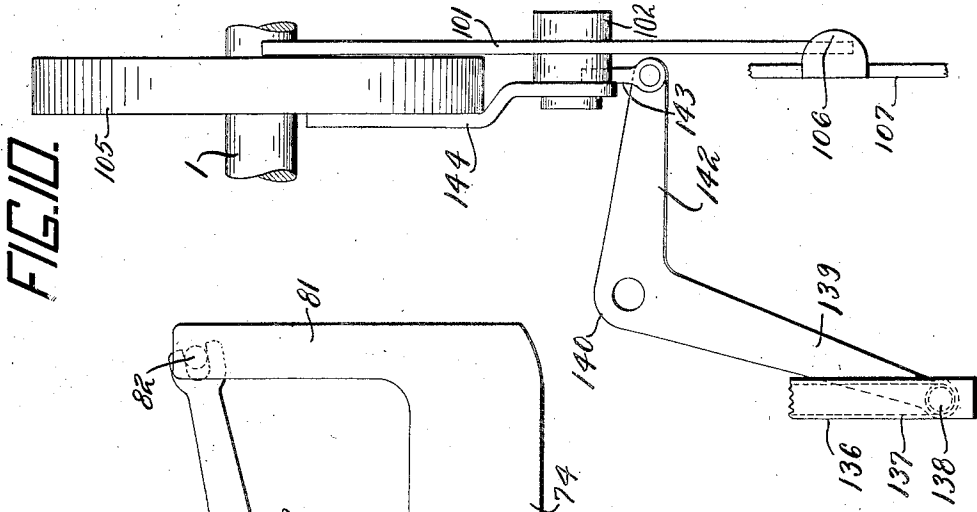

FIG. 10.

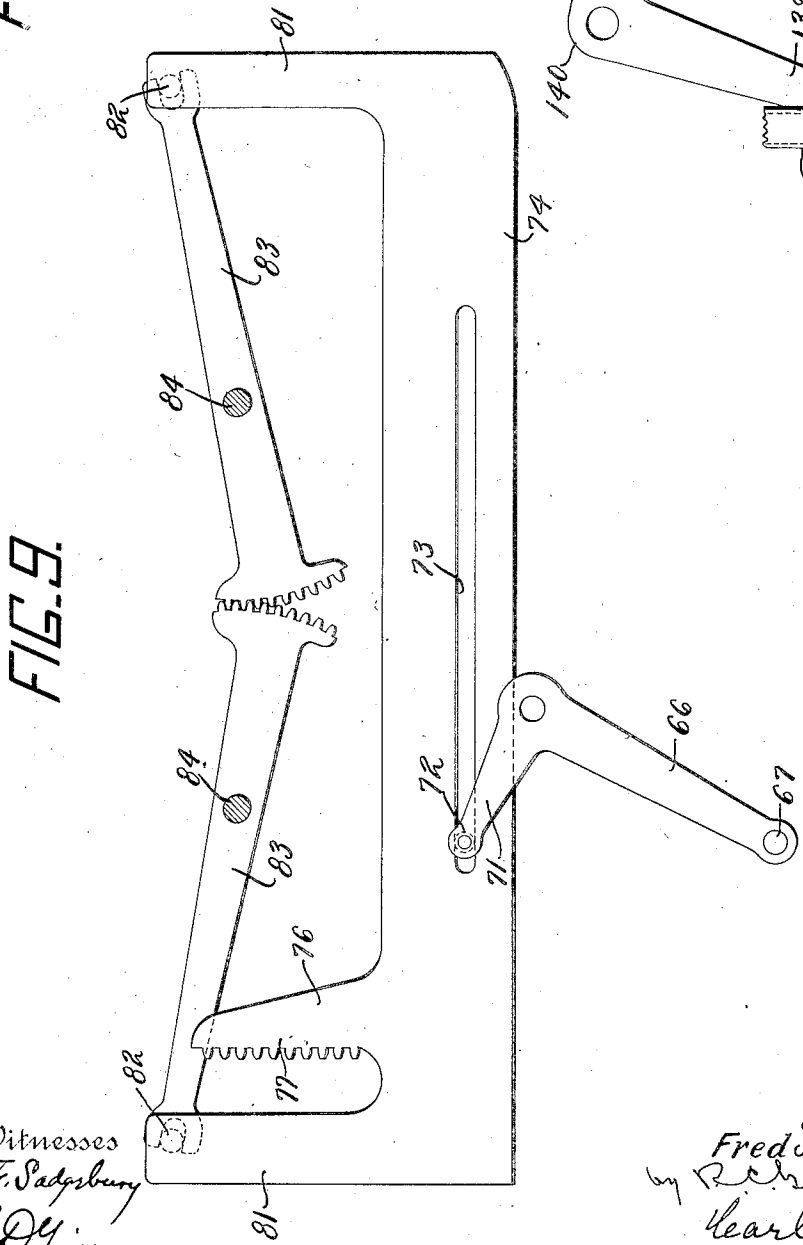

FIG. 9.

Witnesses  
*N. F. Sadgsbury*  
*E. J. Kiven*

Inventor  
*Fred M. Carroll*  
 by *R. S. Sears*  
*Earl Beist*  
 Attorneys

1,245,191.

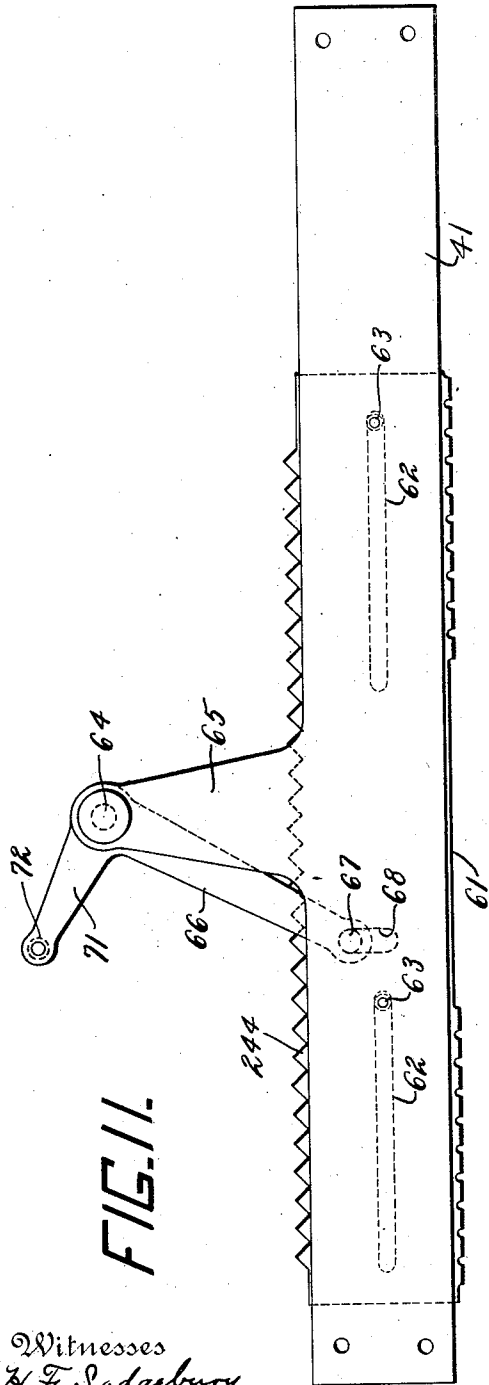

FIG. 11.

Witnesses  
 H. F. Sadgebury  
 J. P. Linn



FIG. 11A

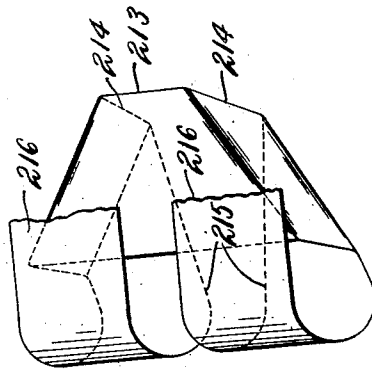

FIG. 12.

Inventor  
 Fred M. Carroll  
 by R. S. Lars.  
 Earl Beust  
 Attorneys

# UNITED STATES PATENT OFFICE.

FRED M. CARROLL, OF DAYTON, OHIO, ASSIGNOR TO THE NATIONAL CASH REGISTER COMPANY, OF DAYTON, OHIO, A CORPORATION OF OHIO, (INCORPORATED IN 1906.)

PRINTING MECHANISM FOR CASH-REGISTERS.

1,245,191.

Specification of Letters Patent.

Patented Nov. 6, 1917.

Application filed March 31, 1915. Serial No. 18,366.

*To all whom it may concern:*

Be it known that I, FRED M. CARROLL, a citizen of the United States, residing at Dayton, in the county of Montgomery and State of Ohio, have invented certain new and useful Improvements in Printing Mechanisms for Cash-Registers, of which I declare the following to be a full, clear, and exact description.

10 This invention relates to improvements in cash registers, and has particular relation to printing mechanisms therefor.

One of the objects of the invention is to provide an improved selecting mechanism for controlling the operations of a plurality of accounting devices. One advantage of this feature of the invention is that it permits arranging the accounting devices in groups or rows and the placing of the selection under the control of a plurality of key banks or a plurality of other manipulative devices such as, for example, the adjustable levers often used instead of banks of keys.

25 In the present embodiment, this selecting mechanism is used in connection with a plurality of record strip devices. As will be more clearly apparent later, however, the mechanism is not limited to this one use, but may be used readily to control the selective operation of other forms of accounting or entry retaining devices.

30 The record strip devices are, in this instance, arranged in two parallel rows, one containing nine and the other ten devices, with the differential mechanism of two key banks of a cash register connected to effect the selection of any one of the devices. One bank controls the row and the other the device which is to be operated in the row. Owing to the fact that there are but two rows of the record strip devices, one of which is always in effective position when the differential mechanism of the row selecting bank is at the normal or zero position, it is necessary to have only one key in the row selecting bank, this key being operated when it is desired to bring the other row of devices to effective position. After the construction is fully understood, however, it will be apparent that by making a few obvious changes more rows of record strip or other devices may readily be added and a controlling key for each of the rows inserted in the row controlling bank.

Another object of the invention is to provide an improved means for connecting the selected accounting device to the main operating mechanism. In the present embodiment of the idea one of the devices which is adjusted when selecting the desired record strip device for operation is arranged also to form the connection and operate the selected platen.

Another object of the invention is to provide improved mechanism for operating a set of type carriers so that they may be caused to print upon any one of a plurality of record strips. In the present instance the type carriers are in the form of bars mounted for differential adjustment in a carriage which is also differentially adjustable directly from one position to another to determine the record strip to be printed upon. While it is not essential, the differential adjustment of all of the type carriers to set up items may be effected simultaneously with the movement of the carriage so that when the carriage comes to rest the item will have been set up opposite the strip on which it is to be printed.

Another object of the invention is to provide mechanism whereby printing against any desired one of a series of platens may be effected by a minimum relative movement between the type carriers and the platens. In the illustrative embodiment the type carriers are provided with two sets of type so spaced apart with reference one to the other and to the platens that the printing line of one set only can be effective at a time and successive steps of movement in the same direction of the devices for effecting the relative movement between the type carrier and the platens will result in the printing lines being brought alternately to effective relationship with the platen mechanism. In this way each set of type will cover a part only of the series of platens and the movement necessary to print against all of the platens in succession is only half as great as if a single set of type was provided to cooperate with all of the platens.

Another object of the invention is to provide mechanism whereby any desired one of a series of accounting devices may be selected for actuation by a minimum relative movement between the actuators and the accounting devices. In the illustrative machine the actuators are adjusted to select

the accounting device to be operated and the actuators are provided with a plurality of engaging means so spaced apart with reference one to the other and to the accounting devices that only one of the engaging means is effective at a time and successive steps of movement of the actuators in the same direction will result in said engaging means being alternately rendered effective. By this construction any desired one of the accounting devices may be selected for actuation with a total range of movement of the actuators only half as great as if but a single one of the engaging means was provided.

Another object of the invention is to provide an improved means for supporting and feeding an ink ribbon common to all of a number of impression devices where said devices are arranged in groups and the general construction does not permit the use of a ribbon wide enough to extend across all of the groups. In the present embodiment of the idea the ribbon support is arranged to hold an endless ribbon of the same width as a single row of the impression devices in such a way that a portion of the ribbon is above each of the rows. The ribbon and its support are carried on one of the invariably moved devices comprised by the machine and suitable means are provided whereby this invariable movement actuates mechanism to drive the ribbon in a constant direction, that is, without reversal of the ribbon feed.

Still another object is to provide devices for insuring equal movement in the same lateral direction of all portions of bars or slides to which power is applied at a single point in such a way that there might, if no such equalizing device were provided, be a rotary or otherwise irregular movement. In the illustrative machine these equalizing devices are applied to plates slidably mounted in a frame with means connected at different points along the edges of the plates for sliding the plates up and down. The equalizing devices insure the same vertical movement of both ends of the plates and thereby prevent the plates from binding in the guiding frame.

With these and incidental objects in view, the invention consists in certain novel features of construction and combinations of parts, the essential elements of which are set forth in appended claims, and a preferred form of embodiment of which is hereinafter described with reference to the drawings which accompany and form part of the specification.

Of said drawings:

Figure 1 is a vertical section taken at the right of the tens of dollars key bank of the improved machine.

Fig. 2 is a vertical section through the

upper part of the printing mechanism. This section is taken on substantially the same plane as the section shown in Fig. 1.

Fig. 3 is a top plan view of the machine showing part of the key board and having the casing broken away to show the general arrangement of the printing devices. In this view the record strip container is run out to the rear from under the type carriers to the position where it may be removed from the machine.

Fig. 4 shows in rear elevation certain features of the register for operating the type carriers and for selectively actuating the record strip platens.

Fig. 5 is a lower left hand portion of a rear elevation of the machine with the casing of the record strip container broken out to show two of the strip feeding mechanisms.

Fig. 6 shows a right hand portion of the rear elevation of the machine.

Fig. 7 shows a lower rear portion of a right side elevation of the machine.

Fig. 8 is a transverse vertical section through the record strip container taken on the same plane as Figs. 1 and 2, with certain of the parts omitted for the sake of clearness.

Fig. 9 is a detail of some of the mechanism for adjusting one of the type carriers and includes the means for equalizing the movement of the type carrier's operating slide.

Fig. 10 is a detail of mechanism for effecting actuation of the selected record strip platens and feeding devices.

Fig. 11 is a detail view showing one of the supporting bars for the type carriers with the type carrier and its operating bell crank assembled thereon.

Fig. 11<sup>A</sup> is a detail view of the under side of a type carrier showing two sets of type.

Fig. 12 is a diagram illustrating in perspective the way in which the ink ribbon is wound over the ribbon supports and feeding rollers.

The machine in the drawings is of the two motion type, that is, its keys may be operated to set up conditions which are entered in the machine by subsequent operation of the operating mechanism. Said machine has seven key banks. The five banks at the right of the key board are for entering amounts while the two banks at the left are the clerks' number keys. The units number bank has a full set or nine keys, while the tens number bank has but a single key. A key may be operated in either number bank or the two number banks may be operated simultaneously, so the machine is obviously intended to take care of the transactions of nineteen clerks. An independent record strip is provided for each clerk and depression of the proper key or keys to

represent the number assigned to a clerk, will, when the machine is operated, effect printing upon that particular clerk's record strip.

5 As already indicated, the record strip devices are arranged in two parallel rows and the type carriers are in the form of bars mounted for differential adjustment in a sliding carriage which is also differentially  
10 adjustable directly from one position to another. The movement of said carriage, also the movement of the type bars to set up items, is in a right and left direction across the back of the machine. The rows of record  
15 strip devices extend parallel to the direction of movement of the type carriers and their carriage and the entire set of strip devices is movable front and back in the machine to bring either of the rows under  
20 the type carriage. The movement of the type bar carriage from one position to another along the row, in operative relation thereto is controlled by the units number keys while the front and back bodily move-  
25 ment to bring either row of strips under the type carriers is controlled by the tens number banks of keys. By this construction printing relationship may be established between the type carriers and any record strip  
30 in either of the rows.

Each of the nineteen record strips has an independent platen and the type bar carriage carries devices for actuating the platen for the strip to be printed upon. Adjust-  
35 ment of the carriage from one position to another not only positions the type to print on the desired record strip but also adjusts the actuating devices to establish operative relationship between the actuating devices  
40 and the platen to be operated. Further operation of the machine then lowers the actuating devices to bring lugs thereon into position to be engaged with the element carrying the platen for the record strip to be printed  
45 upon. The entire set of strip devices is then given a bodily movement to engage said platen carrying element with the lugs and this engagement is maintained while the actuating devices are reciprocated an invariable  
50 extent by the main operating mechanism. This reciprocation positively raises and lowers the platen to take an impression from the type carriers and restores the platen to normal position, after which the set of record  
55 strip devices is given a bodily movement back to normal position to disengage the platen carrier from the lugs on the actuating devices.

The rolls of paper for the record strip devices are carried on studs fastened to the inside of a container or box consisting of two vertical halves hinged together at the bottom and set into a frame which is movable front and back in the machine. From the  
65 rolls the strips pass up over their platens

and then down between a pair of feeding rollers carried by each platen supporting element. These feeding rolls are given a step of movement each time the corresponding platen is actuated thereby feeding the  
70 strip down to a reservoir at the bottom of the container. The arrangement of the record strip devices in the container brings their platens in two parallel rows and the front and back movement of the frame carrying the container is the movement above  
75 mentioned for bringing either row under the type carriers and platen actuating devices. It will be remembered that this movement is controlled by the tens number bank. When  
80 it is desired to remove the record strips or replenish the supply of paper the traveling frame may be run back out of the machine by means operated independently of the control key bank so that the container may be  
85 lifted out of the frame and opened up like a book to give access to the strips.

In addition to the front and back movement of the traveling frame the strip container has a slight left and right movement  
90 of invariable extent in the frame. This is the movement hereinbefore mentioned whereby the platen to be operated is engaged with and disengaged from the actuating devices. This right and left movement is im-  
95 parted by the main operating mechanism through suitable connections at each and every operation of the machine.

The differential mechanisms of the units and tens number banks also control the setting  
100 of the type carriers for these two banks in such a way that the setting of the two type carriers in question is simultaneous with the adjustment of the type carrier carriage and the front and back movement of  
105 the record strip container. The other type carriers are differentially adjusted in the carriage under the control of the differential mechanisms of the five amount banks, which differential adjustment may also be simulta-  
110 neous with the movement of the type carrier carriage and the forward and back movement of the record strip container, although this is not essential. The mechanism may, if desired, be arranged so that  
115 the adjustment of the type carriers is started one after the other, the cents carrier first, then the dimes carrier and so on.

The foregoing statement is thought to give a good general idea of the construction  
120 and operation of the improved machine. The various features will now be described in detail.

#### *Differential Mechanism.*

As shown in Fig. 1 of the drawings the machine to which the improvements have been applied has key controlled differential mechanism of the type shown in an applica-  
125 tion for Letters Patent of the United States 130

filed June 7, 1913, by William A. Chryst, Serial No. 772,276. This mechanism is substantially the same in all the banks, the main difference being that, for reasons above stated, the tens number bank has but a single key instead of nine as provided for each of the other banks. In such a machine all of the mechanism is driven from a shaft 1 which is common to all of the banks. This shaft is given a complete rotation at each operation by means either of an operating handle or a motor as may be desired. To said shaft is fastened a pair of cams 2 and 3 for each bank. Cooperating with each pair of cams is an element 4 pivoted at 5 to the adjacent frame and carrying oppositely extending anti-friction rollers 6 and 7 riding on the edges of the cams 2 and 3 respectively. The arrangement of these parts is such that at each rotation of the shaft and cams the element 4 will be rocked about its pivot 5 first clockwise and then anti-clockwise. Links 8 connect the elements 4 with segments 9 pivoted on a rod 10 extending across the machine. By means of this link connection movement of the elements 4 will be transmitted to said segments and the segments will at each rotation of the shaft 1 be rocked first clockwise and then anti-clockwise through an arc of about 90°. As shown in the application above mentioned, the pairs of cams 2 and 3 may, if desired, be given a slightly spiral arrangement about the shaft 2 so that the segments 9 will not all be started simultaneously.

Loosely mounted upon the rod 10 and adjacent each of the segments 9 is an element 11 having two sets of teeth 12 for actuating totalizers (not shown) and carrying pivoted transfer elements 13. Pivoted to the element 11 is a bell crank 14 and an arm 15. Said arm and the upwardly extending arm of the bell crank 14 have attached thereto pivots supporting a plunger 16 which is at all times drawn toward the central rod 10 by a spring 17. Formed on the segment 9 is a lug 18 above which the rear end of the plunger 16 is normally seated. When the segment is moved clockwise as above described the engagement of the plunger 16, with the lug 18 causes the element 11 to be carried along until a block 20 rigid on the forwardly extending arm of the bell crank strikes the depressed key 22. Continuation of the clockwise movement of the segment 9 causes the bell crank 14 to be rocked about its pivot, drawing the plunger 16 forward and projecting its nose 23 into the one of the notches 24 in the key frame corresponding to the key operated. This disconnects the element 11 from the segment 9 and said element is locked in adjusted position by the rear end of the plunger riding upon the periphery 25 of

the segment 9 until the anti-clockwise or return to normal movement of the segment brings the lug 18 down past the end of the plungers 16 so that the spring 17 can again seat the plunger above the lug. The segment 9 and element 11 then move as a unit the rest of the distance back to the normal starting point.

Pivoted to each of the elements 11 at the same point as the arm 15 is a link 26 having its opposite end loosely connected at the lower end of a link 28 pivoted to a segment gear 30. (Figs. 1 and 2). Said segment gears are loosely mounted on a rod 31 extending across the machine. If the parts are in the positions shown in Fig. 1 and the element 11 is then adjusted to position it with reference to a depressed key, it will be apparent that the link 26 will be carried into engagement with a collar 33 on the rod 10 and that further movement of the element 11 will cause the segment gear 30 to be drawn downward until the element 11 comes to a stop. At the end of the clockwise movement of the element 4 a stud 34 carried by a forwardly extending portion of said element will engage the under side of the link 26 and insure its being in contact with the collar 33. As the stud is then immediately carried out of engagement with the link by the anti-clockwise movement of the element 4, it is apparent that when the element 11 is returned to its normal position the links 26 and 28 will swing loosely on their supporting pivots and permit said return movement without disturbing the setting of the segment gear 30. If at the next operation the element 11 is not carried far enough to bring the link 26 into contact with the collar 33, the stud 34 will move the link the rest of the distance. It will be seen, therefore, that this construction provides a means whereby the segment gear 30 will be adjusted from the position in which it was left at the end of the preceding operation directly to the new position, that is, the segment gear is not returned to a normal starting point at each operation. Suitable means, not shown, are provided whereby if no key is operated in a bank the plunger 16 will be disengaged from the lug 18 on the segment 9 and projected into the lowest one of the notches 24 so as to prevent movement of the element 11 past the zero position. When the element 11 is stopped at zero in this way the clockwise movement of the element 4 and stud 34 will adjust the segment 30 from any position at which it may have been left at the end of the preceding operation directly to the normal or zero position in which it is shown in Fig. 2.

As hereinbefore stated, the type carrier carriage and actuating devices connected

thereto are differentially adjusted from one position to another to effect printing on any desired strip in a row, the type carriers are adjusted in the carriage to set up the item to be printed on said strip and the entire set of record strip devices is given a bodily movement front and back in the machine to bring either row of the devices under the type carriers. The mechanisms whereby these things are accomplished are all actuated by the segment gears 30. The construction and operation of the type carrier carriage and the type carriers will be explained first.

#### *Type Carrier Mechanism.*

The type carrier carriage is made up of seven plates 41 (Figs. 2, 4, and 11), blocks 42 serving to space the plates apart at their ends and a pair of side rails 43, all rigidly secured together by pins 44 so as to form a unitary structure. Both of the side rails 43 have ball races 44 cooperating with races 45 in rails 46 fastened to the stationary supporting plates 47, the arrangement being such that the carriage is free to move in an endwise direction, that is, back and forth across the rear of the machine.

As shown in Figs. 2, 3, and 4, each of the segment gears 30 is in mesh with a spur gear 48. The right hand one of these gears (Figs. 3 and 4), that is, the gear meshing with the segment gear 30 for the tens number bank, is fastened to a shaft 51 extending across the machine. The other gears 48 are rotatably mounted on said shaft. Rigid with all seven of the gears 48 are bevel gears 52 meshing with bevel gears 53 fastened to the inner ends of short shafts 54 rotatably mounted in the supporting frames or plates 47. Differential adjustment of the segment gears 30 as hereinbefore described will, it is clear, effect corresponding differential rotation of the shafts 54 and, in addition to rotating its shaft 54, the differential movement of the tens bank segment gear 30 will also cause differential rotation of the shaft 51. The reason for rotating said shaft 51 will appear later.

Secured to the shaft 54 for the units number bank is a spur gear 55 meshing with a rack 56 (Figs. 2 and 4) fastened along the upper edge of a plate 57 secured to the rear, or, as viewed in said figures, the right hand one of the side rails 43 forming a part of the movable type carrier carriage. The differential rotation of the units number shaft 54 by its segment gear 30 will, of course, cause differential adjustment of the type carrier carriage and by tracing the mechanism all the way back to the units number keys it will be apparent that the construction so far described provides a satisfactory means for adjusting the mov-

able carriage from the position in which it was left at the end of the preceding operation directly to a position corresponding to the units number key operated.

As hereinbefore stated, the type carriers are in the form of bars mounted for differential adjustment in a movable carriage. The carriage and the means for moving it have just been described. A type bar is provided for each of the seven banks of the machine and they are so connected to the differential mechanisms of their respective banks that they may be adjusted to set up items at the same time that the set of bars is being moved bodily by adjustment of the carriage to bring the item in printing relationship to the desired record strip. It has also been explained that the record strip platens for taking the impression are arranged in two parallel rows, one containing nine and the other ten platens and that one or the other of these rows is at all times under the type carriers. The reason why there are but nine platens in one of the rows will be made clear hereinafter. The two rows of platens are of equal length and the platens are spaced apart equal distances in the rows. In order to make it possible to print against any desired platen in a row with a minimum movement of the type bar carriage, each type bar (Figs. 4, 11 and 11<sup>A</sup>) is provided with a set of type at either end the two sets being duplicates in appearance and arrangement and so positioned with reference one to the other on the bars that the type printing digits of the same value are separate a distance equal to five and one-half of the platen spaces.

The differential movement of the type bar carriage and the adjusting movement of the type bars themselves conform to this arrangement of the type, that is, a step of movement of the key controlled differential mechanisms is equal to approximately one-half of a platen space. By this arrangement of the mechanism and type each set of type will cover five of the platens in a row and when the printing line of one set of type is in operative relationship to a platen the printing line of the other set will clear the nearest platen by one-half of a platen space.

As best shown in Fig. 11, each of the type bars 61 has two horizontal slots 62 into which project studs 63 fastened to the adjacent plate 41 (see also Fig. 4). These plates 41, as will be recalled, form part of the movable type bar carriage. Pivoted at 64 to an upwardly extending arm 65 formed on each plate 41 is a bell crank 66. Fastened to the lower end of the downwardly extending arm of said bell crank lever is a stud 67 projecting laterally into a vertical slot 68 in the type bar 61. It is apparent

that the type bar 61 may be adjusted to different positions on the supporting studs 63 by movement of the bell crank 66 about its pivot 64. The means for operating the bell cranks to differentially position the type bars will next be described.

The upper arm 71 of each of the bell cranks 66 has attached thereto a stud 72 extending laterally into a long horizontal slot 73 in a plate 74. There are seven of these plates, one for each type bar, and they are all mounted for sliding vertical movement in the slots of guide frames 75 (Figs. 3, 4, 9, and 11) supported by the rods 70 fastened to the printer side plates 47. Extending upwardly from each plate 74 is an arm 76 one edge of which carries rack teeth 77 meshing with a pinion 78 fastened to the corresponding shaft 54. Differential rotation of the shafts 54 in a clockwise direction, as viewed in Fig. 4, will, it is apparent, cause plates 74 to be lowered differentially and as the plates are lowered they will rock the bell cranks 66 about their pivots 64 thereby effecting adjustment of the connected type bars on the supporting studs 63. The connection formed by the studs 72 and slots 73 in the plates 74 permits movement from one position to another of the type bar carriage to which the bell cranks 66 are pivoted while at the same time the bell cranks may be rocked about their pivots by movement of the plates 74 to adjust the type. In this way the type bars are adjustable by their differential mechanisms to set up items during the same time that the type bars are being moved bodily by adjustment of the carriage under control of the units number bank differential mechanism to select the recording strip to be printed upon. The adjustment of all the type bars and the adjustment of the carriage may, as stated, be simultaneous though this is not essential. As shown, however, differential rotation of the shaft 54 associated with the units number bank acting through the gear 55 and pinion 78 effects simultaneously the differential adjustment of the type bar carriage and the differential or item setting movement of the units number bank type bar. It is clear that this simultaneous movement of the type bar carriage and the units number bank type carrier provides a means whereby the units type bar may be positioned to print any desired digit on any desired one of the series of record strips resting at the time under the carriage.

#### *Equalizing Devices.*

As shown in Figs. 4 and 9 the rack arms 76 of the plates 74 are positioned at different points on their respective plates to bring the racks into cooperative relationship with the pinions 78 carried by the corresponding shafts 54. The nature of the connection

formed by the rack arms and the pinions is such that, if no means were provided to prevent it, all points of the plates would not have the same vertical movement and the tendency would be for the plates to bind in the guide frames 75. To prevent any such binding equalizing devices are provided. To this end extensions 81 formed on the plates 74 and cooperating with the guides 75 carry at their upper ends studs 82 engaging open slots in the ends of levers 83. These levers are pivoted on rods 84 supported by the printer side plates 47 and are equipped at their inner ends with intermeshing toothed segments. It is clear that this construction provides a means whereby power applied to any point of a plate 74 will be transmitted through the levers 83 to effect equal vertical movement of both ends of the plate.

#### *Platen Operating Devices.*

The devices for selectively actuating the platens comprise two plates 85 (Figs. 2, 4, and 6) having vertical slots 86 into which project short studs 87 secured to the side rails 43 forming part of the movable type bar carriage. The rails 43 and 46 are separated a sufficient distance to make room for the plates 85 while the portion of the plates between the rails is short enough to permit endwise movement of the plates without interference from the balls in the ball races formed in the rails. Each of the actuator plates 85 has two long horizontal slots 88 (Figs. 4 and 6). Into the left hand ones of these slots (Fig. 4) project studs 91 carried by the lower arms of bell cranks 92 pivoted on a rod 93 mounted in the printer side plates 47. The right hand slots 88 (Fig. 6) surround studs 94 attached to one of the arms of multi-armed elements 95 journaled on a rod 96 which is also supported by the printer side plates 47. Long links 97 connect upwardly extending arms of the bell cranks 92 with the downwardly extending arms of the multi-armed elements 95. From the mechanism so far described, it is apparent that because of the connection formed by the slot 86 and stud 87 differential adjustment of the type bar carriage as above described will also effect differential adjustment of the plates 85 on the studs 91 and 94 also that if the multi-armed elements 95 are oscillated first anti-clockwise and then clockwise the result will be first to lower and then raise the plates 85. This movement of the elements 95 is imparted twice at each operation of the machine by suitable connections to the main operating mechanism.

The connections just mentioned include a lever 101 (Figs. 3, 6, 7, and 10) pivoted to a rearwardly projecting lug 102 (Fig. 7) on the rear main frame of the machine. At

one end said lever is equipped with an anti-friction roller 103 projecting into a cam groove 104 formed in the side of a disk 105 fastened to the main driving shaft 1. It will be recalled that said shaft is given a complete rotation at each operation of the machine. The free end of the lever 101 rests between ears 106 (Figs. 3, 6, and 10) formed on a yoke 107 rigidly fastening together the two long arms 108 of the multi-armed elements 95. As shown in Fig. 7, the configuration of the cam groove 104 is such that during the latter half of the rotation of the shaft 1 the lever 101 will be oscillated twice on its pivot, each oscillation consisting of first an anti-clockwise and then a clockwise movement with a slight pause at the end of each of the anti-clockwise movements. These movements of the lever, because of the engagement of its free end with the ears 106 on the yoke 107, is transmitted to the elements 95 and 92 and the plates 85. The result is that the plates 85 are lowered to a certain position, held stationary an instant in the lowered position, then returned nearly to normal, then again lowered to the same position as before and held stationary in that position for an instant before they are raised to their normal positions. These movements of the plates 85 are simultaneous, in fact, owing to the rigid yoke connection between the multi-armed elements 95 the plates 85 are for all practical purposes parts of a unitary structure for actuating the platens.

Each of the plates 85 is provided with two L-shaped actuating lugs 111 (Figs. 2, 4, and 5) the lugs at the same ends of the plates forming a platen operating pair. The lugs are so positioned with reference one to the other on their respective plates 85 that they are, like the two sets of type on the type bars, separated a distance equivalent to five and one-half of the platen spaces, the pair of lugs at either end of the plates cooperating with but five of the platens in a platen row and when one pair of the lugs is in position to operate a platen the other pair will be one-half of a platen space away from the position in which they would be effective to operate one of the platens. As previously explained the connections between the differential mechanism controlled by the units number keys and the type bar carriage to which the actuator plates 85 are connected are so proportioned that a step of movement of said differential devices moves the carriage and consequently the actuator plates 85 a distance equal to one-half of a platen space. This movement of the actuator plates, in connection with the arrangement of the lugs 111 on the plates, provides a means for selecting any one of the ten platens for operation by a minimum movement of the actuator plates. The con-

struction of the differential mechanism and intermediate connections also provides a means whereby the actuator plates may be moved by an operation of the machine directly from the position in which they were left at the end of the preceding operation to the position corresponding to the units number key operated. This adjusting movement occurs during the first half of the operation of the machine or before the actuator plates are given the two vertical movements above mentioned.

The nineteen platens 112 for taking impressions from the type carriers are each mounted in a carrying element 113 (Figs. 2, 3, and 8) suitably mounted for sliding vertical movement in the sides 114 of the record strip box or container. As best shown in Fig. 8 said container consists of two vertical halves hinged together at or near the bottom by links 115 pivoted as at 116 to the end plates of the container. The bottom portions 117 of the container have slots 119, as shown in Fig. 8, under the links 115 so that said bottom portions will clear the links thereby making it possible to, when a container is out of the machine, spread it open like a book so as to have free access to the interior when removing the printed records or supplying fresh paper.

The container, when in the machine, sets in a rectangular opening in a traveling frame 118 having ball races in the end portions thereof cooperating with ball races 120 in rails 121, fastened at one end to frames 122 supported by a rod 123 across the machine and at the other to the adjacent main frame of the machine. As shown in Fig. 3 the end portions of the frame 118 extend far enough toward the front of the machine to support the record strip container when the container is run to the extreme rear to permit lifting the container out of the frame. The means for moving the frame 118 to the extreme rear operates independently of the differential devices of the machine and will be described later. The connections whereby the container is adjusted by the tens number bank differential mechanism comprises a rack 124 rigidly attached to the right hand end of the frame 118 (Fig. 6) said rack being normally in engagement with a pinion 125, rigidly attached to a short sleeve 126. Said sleeve is splined at one end of a shaft 127 so that while the sleeve and pinion are capable of a lateral movement on the shaft the shaft cannot rotate without imparting rotary movement to the pinion 125 and sleeve 126. Secured to the other end of the shaft 127 is a bevel gear 128 meshing with a bevel gear 131 fastened to the lower end of a vertical shaft 132 rotatably mounted in extensions from the machine frame and having

attached to its upper end a bevel gear 133 meshing with a bevel gear 134 fastened to the shaft 51. The shaft 51, it will be recalled, is rotated by movements of the segment gear 30 connected to the tens number bank differential mechanism. When all the differential devices of the units and tens number bank are at the normal or zero position the traveling frame 118 is in its forward position, that is, with the rear row of record strip devices under the platen actuators and type carriers as shown in Fig. 2. If the machine is operated with only a units number key depressed the record strip devices remain in this position. If, however, the machine is operated with the key in the tens number bank depressed, the resulting movement of the tens number bank segment gear 30 will, because of the rotation of the shaft 51, 132, and 127, cause the pinion 125 to rack the traveling frame 118 toward the rear of the machine and bring the other row of record strip devices under the type carriers and platen actuators. As shown in Fig. 3, the single key in the tens number bank is at the top of the bank. By placing it at the top, instead of at the bottom where it would ordinarily be, the full nine steps of movement of the element 11 and segment gear 30 of the tens number bank may be used to effect the front and back movement of the traveling frame 118, while if the key was placed at the bottom of the bank said front and back movement of the traveling frame would have to be effected by a single step of movement of the tens number bank segment gear 30. The latter arrangement obviously would be unsatisfactory, as moving the frame 118 and record strip devices by a single step of movement of the segment gear 30 would result in too quick a movement of the frame and would cause the machine to run comparatively hard at that particular point in the operation.

When the container is set down in the traveling frame 118, it is supported by two pairs of rollers or wheels 129 rotatably mounted on the sides of the container and resting upon two short tracks 130 formed on the side members of the frame. The inside length of the rectangular opening in the frame 118 is enough greater than the length of the record strip box or container to permit a slight endwise movement of the container on the tracks 130. At the right hand end of the container, as viewed from the rear, Fig. 6, is a bar 136 in the lower edge of which is a slot 137 (see also Fig. 7). Into said slot projects an anti-friction roller 138 mounted on the rearwardly extending arm 139, Figs. 6, 7, and 10, of a bell crank lever 140, pivoted as at 141 to an arm rigid with the extension of the machine frame in which the shaft 127 is journaled. The bar

136 is fastened to the rearmost half only of the container so as to permit opening the container, but it is long enough for its slot 137 to remain in engagement with the roller 138 when the container is moved to the rear of the machine by the tens number bank differential mechanism. The slot 137 is open at its forward end, that is, the end nearest the front of the machine, so that when the frame 118 and the record strip box are moved to the extreme rear to permit removal of the box, the slot will pass out of engagement with the roller 138. The other arm 142 of the bell crank 141 is connected by a short link 143 to the lower end of a bell crank 144 pivoted at its upper end to the lug 102 on the machine frame (see Figs. 6, 7, and 10). The other or forwardly extending arm of the bell crank 144 carries an anti-friction roller 145 (Fig. 7) projecting into a cam groove 146 formed in the side of the disk 105 opposite the side in which the cam groove 104 is formed. The shape of the cam groove 146 is such that almost immediately after the first half of the operation of the machine is completed the bell crank 144 is rocked clockwise (Fig. 7) on its pivot, thereby through the link 143 rocking the bell crank 140 clockwise (Fig. 10) on its pivot. This shifts the container toward the right as viewed from the rear of the machine and holds it in that position during approximately one-fourth of the operation of the machine after which the parts are all restored to their zero positions.

As shown in Figs. 2 and 8, each of the vertically movable platen carrying elements 113 is provided with extensions 151 and 152 the latter extension serving in connection with the body of the element 113 to form a notch 153. These extensions cooperate with the L-shaped lugs 111 on the platen actuating plates 85. When the plates 85 are first lowered as above described, the lugs 111 are brought down to a position where the shifting movement imparted to the container by the bell crank 140 will carry the extensions 151 and 152 of the platen to be operated above the lugs 111 on the actuator plates. The engagement thus effected is maintained while the actuator plates are raised and lowered to operate the platen. When the plates are in the lowered position after operating the platen the bell crank 140 shifts the container back to its normal position disengaging the platen from the actuator plates after which the plates are restored to their original positions. The engagement of one of the lugs 111 with the notches 153 affords a means whereby when the actuator plates are lowered after the impression is taken the platen carrying element 113 will be positively lowered to its normal position.

As shown in Figs. 3 and 5 one of the rec-

ord strip devices is omitted from the rear-most row. This row is the one that is under the type carriers and platen actuators when the tens number bank segment gear 30 is at the zero position, and the point where the platen is missing is the one with which the right hand lugs 111 (Fig. 5) of the actuator plates would be in operative relationship when the units number bank segment gear 30 controlling the movement of the actuator plates is at the normal or zero position. It is apparent that if the machine could be operated with both of the segment gears 30 held at the zero position, a record strip device at the point where the device is omitted would be operated when the record strip container is shifted and the actuator plates reciprocated. A machine lock (not shown) is provided, however, which prevents operation of the machine unless at least one of the number keys is depressed. As a result either the platen actuators or the record strip container or both will be moved from the zero positions in which they are shown and a record strip device at the point corresponding to the zero position of the two number bank differential mechanisms would be useless because it would never be operated.

#### Record Strip Feeding Devices.

The rolls of paper for the nineteen record strips are carried by supply rollers 155 (Fig. 8) rotatably mounted on studs 156 arranged in double horizontal rows and projecting inwardly from the sides 114 of the record strip container. From the supply roller each strip passes up over the top of its platen carrying element 113 and platen 112, down between a feeding roller 157 (Fig. 5) and a tension roller 158. The feeding roller 157 is rotatably mounted on a stud 161 secured to the platen carrying element 113 while the tension roller is rotatably mounted on a rod 162 supported in the downwardly extending arms of a yoke-shaped frame 163. Said frame is journaled in a stud 164 also fastened to the platen carrying element 113. A torsion spring 165 wound around the stud 164 engages the frame 163 and a spring pin in the platen carrying element 113 the arrangement being such that the roller 158 is always held against the roller 157. Attached to one end of the feeding roller 157 is a ratchet wheel 166. Coöperating with the teeth of the ratchet wheel is a spring pressed pawl 167 pivoted at its lower end on a stud 168 fastened to the side 114 of the record strip box or container. From this construction it follows that when the platen carrying element 113 is raised by the actuating lugs 111 the pawl 167 will be operated by its spring to cause the end of the pawl to engage the next tooth of the ratchet wheel and when the platen carrying element

is positively lowered to its starting point the ratchet wheel and connected feeding rollers will be turned one division thereby spacing the record strip. A retaining pawl 172 is held in engagement with the teeth of the ratchet wheel by a spring 173 so as to prevent retrograde movement of the feeding roller. After being fed through between the rollers 157 and 158 the strip passes down between the supply rolls to a space provided for the purpose at the bottom of the container.

#### Inking Ribbon Mechanism.

An endless ribbon 175 (Figs. 3 and 5) for inking the type is carried by a removable frame arranged to hold a single strand of the ribbon above each row of platens 112. Said frame consists of end members 176 and 177 connected together by side rods 178. The rods 178 are rigidly fastened in the members 176 but are capable of a sliding endwise movement in the members 177. Springs 181 compressed between pins 182 in the rods 178 and the member 177, tend at all times to force the members 176 and 177 apart, the purpose being to provide a means for keeping the inking ribbon under tension. The member 177 has a downwardly extending portion 281 (Fig. 6) having two vertical open ended slots (not shown) each engaging the shanks of two screws 282 fastened in vertical alinement in the end of the record strip box. The heads of the screws prevent horizontal movement of the member 177 away from the container. The end member 176 has two vertical slots (not shown) to engage studs 183 fastened to the left hand end (Fig. 5) of the record strip container. Only one of the studs 183 and two of the screws 182 appear in Fig. 5 because the other studs and screws are in horizontal alinement with the ones shown and are, of course, concealed from view. The studs 183 are cylindrical in shape and long enough properly to support the member 176 even though said member should be moved some little distance away from the end of the container by the action of the tensioning springs 181.

Rigid with the end members 176 and 177 of the ribbon frame are extensions 184 (Fig. 3) in each of which is rotatably mounted a pair of short shafts 180 to each of which is fastened a ribbon feeding roller 185. Fastened to the adjacent ends of the shafts 180 are bevel gears 186. Meshing with the pair of bevel gears 186 at either end of the ribbon frame is a bevel gear 187, both of the gears 187 being fastened to the opposite ends of a shaft 188 extending longitudinally of the ribbon frame and journaled in the end members 176 and 177 and the extensions 184 thereof. The shaft 188 is in two sections, one of which is rigid with a sleeve 191 and

the other of which has a squared end (not shown) loosely inserted in a similarly shaped hole in the sleeve so that while the sections of the shaft rotate as a unit they do not prevent movement of the member 176 by the ribbon tensioning springs 181.

Rigid on the shaft 180 for the rear right hand feeding roller 185 (Figs. 3 and 6) is a ratchet wheel 192. Adjacent the ratchet wheel is a plunger 193 mounted for both endwise and rotary movement in a guide 194, rigid with the extension 184. A spring 195 in the guiding hole for the plunger is fastened by a pin 196 to the inner end of the plunger 193 and is held at the other end by a pin 197 which extends through the wall of the guide into the plunger hole. The arrangement is such that the spring 195 at all times has a slight tendency to force the plunger 193 outward or to the right (Fig. 6), but is at the same time always under a slight torsional stress tending to rotate the plunger in its guide. The latter function of the spring is to hold a pin 198 fastened to the plunger in engagement with the teeth of the ratchet wheel 192. The exposed end of the plunger contacts a plate 199 fastened to the frame 122. When the record strip container is shifted to engage the selected platen with the actuating lugs 111, the plunger 193 will be held stationary by the plate 199 and the square side of the pin 198 will engage the teeth of the ratchet wheel 192, rotating the ratchet wheel and the shaft 180 to which it is attached. This movement is transmitted by the bevel gear 186 fastened at the end of the shaft 180 to the bevel gear 187 fastened to the shaft 188 causing rotation of the shaft and gear 187 to drive the other three bevel gears 186 and the feeding rollers 185 rigid therewith. By tracing the movement from the ratchet wheel 192 through the bevel gearing to the various feed rolls it will be seen that the feed rolls are all driven simultaneously and to an equal extent. The endless ribbon is wound over these rollers in such a way that movement of the rolls will advance the ribbon in a constant direction, that is, without any reversal of the movement of the ribbon.

As shown in Fig. 3, the plate 199 is long enough to cooperate with the plunger 193 when either of the rows of platens is under the type carriers. At its rear edge the plate 199 is beveled slightly and the end of the plunger 193 is rounded so that when the traveling frame 118 and record strip container are restored to normal from the position in which they are shown in Fig. 3, the beveled edge of the plate 199 will cooperate with the rounded end of the plunger to cam the plunger back to its normal position in the guide 194. It should be stated here, however, that the spring 198 is compressed but a very little when the plunger 193 is

in normal contact with the plate 199, so that when the plunger is moved out of contact with the plate the spring will project it only a short distance beyond its normal position in the plunger guide.

The sides 211 of the ribbon frame extensions are divergent so that so far as the outside lines are concerned said extensions when viewed from the top are substantially V-shaped. The upper and lower edges of the sides 211 are parallel and inclined slightly as shown in Figs. 5 and 6. When a new ribbon is to be put on the entire frame is lifted off of the supporting screws 182 and studs 183 and the old ribbon removed. The new ribbon is then laid across the top of the sides 211 of either one of the extensions and drawn under the lower edges of the sides 211 and up over the feeding rollers 185 at that end of the frame. The two strands of ribbon are then carried to the opposite end of the frame where the ribbon is laid across the top of the other pair of sides 211 and looped down under the lower edges of said sides and up over the second pair of feeding rollers 185. Before looping the ribbon over the sides 211 and feeding rollers 185 at the second end of the frame the springs 181 are compressed to bring the two pairs of feeding rollers 185 to less than the normal distance apart. After the ribbon is in position the springs are permitted to expand and tension the ribbon after which the frame is set back in position on the record strip container. Supporting wires 212 attached to the end members 176 and 177 of the ribbon frame hold the ribbon up out of contact with the platens.

When in position the ribbon at either end of the frame is in the shape shown in Fig. 12 wherein the portion 213 corresponds to the part laid across the sides 211, the portion 214 to the parts extending down across the sides 211, the portions 215 to the parts drawn under the lower edges of the sides 211 and up over the feeding rollers, and the portions 216 to the strands carried over the guide wires 212 to the other end of the frame.

#### *Mechanism for Moving the Record Strip Container to the Extreme Rear.*

The mechanism for moving the traveling frame 118 and record strip container to the extreme rear position in which they are shown in Fig. 3 comprises a gear 221 (Figs. 5 and 7) secured to a short shaft 222 mounted for both endwise and rotary movement in a sleeve 223, rigid with a downwardly extending arm 224 integral with the stationary side rail 121 for the traveling frame 118. Rigid with the gear 221 is a collar 225 having an annular groove 226. Engaged with and straddling the reduced portion at the bottom of said groove is the forked end of

an arm 227 fastened to a shaft 228. Said shaft is suitably supported for endwise movement and to its right hand end is fastened an arm 231 (Fig. 6) forked at its rearward end to straddle the reduced portion at the bottom of an annular groove in the slidable sleeve 126 to which the pinion 125 is fastened. Attached to the frame 118 at the left hand side as viewed from the rear of the machine in Fig. 5 and also showing in Fig. 7 is a long rack 232. When it is desired to move the traveling frame 118 and the container to the rearmost position a key or crank is engaged with the squared end 233 of the shaft 222 and the shaft shifted endwise against the tension of a spring 234 compressed between the sleeve 223 and an element 235 fastened to the shaft. This endwise movement of the shaft 222 engages the teeth of the gear 221 with the teeth of the rack 232 and said endwise movement is transmitted by the arm 227, shaft 228 and arm 231 to the sleeve 126, thereby shifting the sleeve and the pinion 125 attached thereto to disengage the teeth of the pinion 125 from the teeth of the rack 232. This disconnects the record strip container from the tens number bank differential mechanism. The gear 221 is now rotated clockwise (Fig. 7) until the frame is rocked far enough to the rear to permit removing the ribbon frame and lifting the container out of the traveling frame 118. Reverse rotation of the gear 221 will restore the frame and container to normal position in the machine.

As shown in Fig. 5 the hub of the gear 221 is provided with a squared shoulder 236 normally in engagement with a notch 237 in the stationary sleeve 223. When the gear 221 is shifted into engagement with the rack 232 and turned, the shoulder 236 is carried out of engagement with the notch 237 and prevents disengaging the gear from the rack until the shoulder is again brought opposite the notch by rotation of the gear. When the shoulder reaches a position opposite the notch the spring 234 will restore all of the devices from their shifted to their normal positions, thereby disengaging the gear 221 from the rack 232 and restoring the pinion 125 to engagement with the rack 124.

Endwise movement of the shaft 222 to engage the gear 221 with the rack 232 also operates a lock (not shown) to prevent operation of the machine until the shaft is restored to normal position. To this end the element 235 which as stated, is fastened to the shaft 222 has a beveled face 238 cooperating with the bent lower end of a long bar 241. This bar is connected at its upper end to the machine lock mentioned and at its lower end is slidably supported by a screw 242 projecting through a slot in the bar into the end of a stud 243 secured to a shoulder on the support 224. It is apparent that

when the shaft 222 is shifted to the right (Fig. 5) to engage the gear 221 with the rack 232 the bar 241 will be cammed upward. This upward movement of the bar operates the machine lock and when the shaft 222 is restored to its first or outer position the bar is free to return to the position in which it is shown.

#### *Type Carrier Alining Devices.*

Each of the type carriers is provided with a series of notches 244 (Figs. 4 and 11) in its opposite edge. Extending across all of the type carriers is an alining element 245 (Figs. 4 and 6) pivoted on a rod 246 fastened in the printer side plates 47 and having an edge 247 suitably shaped to cooperate with the notches 244. Arms 248 rigid with the alining element 245 are provided with slots 249 into which project studs 250 attached to upwardly extending arms 251 of the multi-armed elements 95. The slots 249 are so shaped that when the multi-armed elements 95 are rocked by the lever 101 the alining element 245 will be immediately rocked about the rod 246 to engage the edge 247 with the notches 244 in the type bars and hold said edge firmly in engagement with the notches while the impression is being taken from the type.

#### *Operation.*

The nature of the improved mechanism is such that in order to make the foregoing description as clear as possible, it was necessary to state the operation considerably in detail as an incident to explaining the various features of construction. A complete re-statement here of the operation is therefore believed to be unnecessary. However, a brief general statement in connection with operations involving different number keys and combinations of number keys may be of some assistance in gaining a clear knowledge of the invention.

If all of the various devices are at their normal or starting positions the type carriers 61 and platen actuators 85 are held by the movable type bar carriage in the positions shown in Figs. 4, 5, 6, and 7, and the rearmost row of record strip devices is under said carriage and actuators. At this time the right hand actuating lugs 111, as viewed in said Fig. 5, are in proper position to be engaged by a platen when the record strip container carrying the platen bed is shifted to the right, but for reasons already stated and which need not be repeated here the record strip device is omitted from that position. If, however, the "10" number key is depressed, the record strip container is moved rearwardly by operations of the tens number bank differential mechanism and the intervening connections to bring the forward or full row of record strip devices under the

type carriers and actuators. The type carrier carriage and actuators will remain undisturbed in the position shown. After the record strip container is moved rearward the platen actuators are lowered to bring the lugs 111 into position to be engaged by the sixth platen from the left in the forward row (Figs. 3 and 5) when the container is shifted to the right. Further operation of the machine effects actuation of said platen and its subsequent disengagement from the actuators.

If all of the various devices are at their starting positions and the machine is operated with the "1" key depressed in the units number bank, the record strip container will remain in its forward position with the rearmost row of record strip devices under the type carriers and platen actuators. The type carrier carriage will, however, be moved a single step to the right (Fig. 5) by the units number bank differential mechanism, this step being equal to one-half of a platen space, and bring the lugs 111 at the right of the first platen at the left hand end of the row. The right hand lugs 111 will, by this movement of the actuator plates and because of the distance at which the lugs are spaced apart on their respective plates, be brought to the left of the seventh platen, counting from the left hand end of the row. When the actuator plates are lowered and the platen bed shifted the first platen at the left will be carried into engagement with the left hand lugs 111 while the seventh platen from the left will be carried away from the right hand lugs 111. Then when the actuating movement of the actuating plates occurs the first platen only will be operated.

If, instead of the "1" number key, the "2" number key had been depressed, the subsequent movement of the units number bank differential mechanism would effect adjustment of the type carrier carriage and actuator plates two steps, each step equal to one-half of a platen space, thereby bringing the right hand lugs 111 to the right of the seventh platen from the left hand end of the row and the left end lugs to the left of the second platen from the left end. Then when the engaging movements of the actuators and platen bed occurred the seventh platen would be engaged with the right hand actuating lugs 111 while the second platen would be carried away from the left hand lugs 111. If the "3" units number key had been depressed, the resulting movement of the type bar carriage and actuators would bring the left hand lugs 111 to the right of the second platen from the left so that said second platen would be engaged and operated. Operation of the machine with the "4" units number key would effect operation of the eighth platen from the left, the "5" units number key would effect operation

of the third platen from the left, and so on. Movement of the type bar carriage not only adjusts the actuators as just described, but at the same time bodily moves the type bars so that when the selected platen is operated, the impression is taken from the printing line of type in alinement between whichever pair of lugs effects the operation. It is thought that the operation of the type carriers to set up items at said printing lines has already been made clear and need not be repeated here.

If the machine is operated with both the tens number key and one of the units number keys depressed, the differential devices of the units and tens bank operate simultaneously to shift the platen bed rearward to bring the forward row of platens under the actuators and type carriers, while the type carriers and actuators are being moved to position the proper actuating lugs and printing line of type in operative relationship to the desired platen in said foremost row. For example, if the mechanism is all at the starting point and the machine is operated with number keys depressed to represent the clerk to whom the number "12" has been assigned, the platen bed is shifted rearward to bring the forward row of platens under the type carriers and platen actuators and during the same time the platen actuators are moved to the right to bring the right hand lugs 111 to the right of the seventh platen, counting from the left hand end of the platen row. Then when the platen bed is shifted to effect engagement, said seventh platen will be engaged with the right hand actuating lugs 111 and the platen then actuated to take the impression.

While the form of mechanism herein shown and described, is admirably adapted to fulfil the objects primarily stated, it is to be understood that it is not intended to confine the invention to the one form of embodiment herein disclosed, for it is susceptible of embodiment in various forms all coming within the scope of the claims which follow.

What is claimed is:—

1. In a machine of the class described, the combination with a plurality of entry retaining devices arranged in groups, selecting mechanism therefor, and a plurality of manipulative devices simultaneously operable to control said mechanism to select for operation any entry retaining device in any group.

2. In a machine of the class described, the combination with a main operating mechanism, of a plurality of entry retaining devices arranged in groups, selecting mechanism differentially driven by the main operating mechanism, and a plurality of manipulative devices simultaneously operable to control said selecting mechanism to

select the group and the entry retaining device to be operated in the selected group.

3. In a machine of the class described, the combination with entry retaining devices arranged in groups, of an operating means common thereto, a plurality of manipulative means operable to select the group and the retaining device to be operated in the selected group, and differential mechanism controlled by said manipulative devices for establishing operative relationship between the aforesaid operating means and the selected entry retaining device.

4. In a machine of the class described, the combination with a plurality of record strip devices, of manipulative devices operable in combinations to select the record strip device which is to receive the record, and intervening mechanism controlled by said manipulative devices for effecting the operation of the selected device.

5. In a machine of the class described, the combination with an operating mechanism, of a plurality of record strip devices arranged in rows, a device for connecting any desired record strip device with the operating mechanism, manipulative devices, and differential mechanism controlled by the manipulative devices for establishing operative relationship between the connecting device and any desired record strip device in either of the rows.

6. In a machine of the class described, the combination with an operating mechanism, of a plurality of record strip devices arranged in rows, a device for connecting any desired record strip device with the operating mechanism, manipulative devices, differential mechanism controlled by the manipulative devices for establishing operative relationship between the connecting device and any desired record strip device, and means for rendering the connecting device effective to connect the desired record strip device with the operating mechanism.

7. In a machine of the class described, the combination with a plurality of record strip devices, of a movable support for the record strip devices whereby said devices may be moved as a unit; a differentially adjustably record strip device actuating means common to the record strip devices, manipulative devices, and mechanism controlled by the manipulative devices for simultaneously moving the record strip devices and the actuating means to establish operative relationship between said actuating means and any desired record strip device.

8. In a machine of the class described, the combination with an operating mechanism, of a plurality of type carriers, a plurality of rows of record strip devices any one of which devices may be operated at an operation of the operating mechanism, manipulative

devices, and differential mechanism controlled by said manipulative devices for simultaneously setting the type carriers and establishing operative relationship between the operating mechanism and the desired record strip device.

9. In a machine of the class described, the combination with an operating mechanism, of a bank of keys, a type carrier, a series of independently operable record strip devices, an element differentially positioned by the operating mechanism under the control of the keys, and means whereby the positioning of the differential element determines both the setting of the type carrier and the record strip device to be operated.

10. In a machine of the class described, the combination with a type carrier, of a series of holders for independent record strips, and means for adjusting the type carrier to print any desired character thereon on any desired record strip.

11. In a machine of the class described, the combination with a main operating mechanism, of a type carrier, a series of holders for record strips, manipulative devices, and means driven by the main operating mechanism under the control of the manipulative devices for adjusting the type carrier to print any desired character thereon on any desired record strip.

12. In a machine of the class described, the combination with a set of type carriers, of a plurality of holders for independent record strips, means for operating the carriers to set up items thereon, and means for moving the set of carriers directly from one position to another whereby to print the item on any desired record strip.

13. In a machine of the class described, the combination with a plurality of manipulative devices, of a set of type carriers, a series of independent record strip devices, and mechanism controlled by the manipulative devices for setting up items on the type carriers and positioning the type carriers to print on any desired record strip.

14. In a machine of the class described, the combination with a set of type carriers, of a plurality of record retaining devices each comprising a record strip, means for differentially adjusting the carriers directly and in either direction to set up items thereon, and means for bodily moving the set of carriers directly and in either direction whereby to print the item on any desired one of the record strips.

15. In a machine of the class described, the combination with a plurality of groups of impression devices, of manipulative devices operable in combinations to select the group and the impression device to be operated in the selected group, and selecting mechanism controlled by said manipulative devices.

16. In a machine of the class described, the combination with a plurality of vertically movable impression devices arranged in groups, of a movable support for the impression devices, an actuating device common to all of the impression devices and adjustable to different positions, means for adjusting the movable support in one direction to determine the group, and means for moving the actuating device in a different direction to determine the impression device to be operated in said group.

17. In a machine of the class described, the combination with a plurality of impression devices arranged in groups, of a movable support for the impression devices, an actuating device common to all of the impression devices and adjustable to different positions, and means for simultaneously adjusting the movable support in one direction and the actuating device in a different direction whereby to determine the group and the impression device to be operated in the group.

18. In a machine of the class described, the combination with a main operating mechanism, of a series of impression devices, an operating means common to the impression devices and constructed to positively raise and lower any one of the impression devices, mechanism for differentially adjusting the operating means directly from one position to another to establish operative relationship between said means and any desired impression device, and means for operatively connecting and disconnecting said impression device and the operating device.

19. In a machine of the class described, the combination with a plurality of manipulative devices, of a main operating mechanism, a plurality of impression devices, arranged in groups, a movable support for the impression devices, an actuating device common to all of the impression devices and adjustable to different positions, and means driven by the main operating mechanism under the control of the keys for adjusting the movable support in one direction and the actuating device in a different direction to determine the impression device to be operated in the group.

20. In a machine of the class described, the combination with a plurality of manipulative devices, of a main operating mechanism, a plurality of impression devices arranged in groups, a movable support for the impression devices, an actuating device common to all of the impression devices and adjustable to different positions, and means driven by the main operating mechanism under the control of the manipulative devices for simultaneously adjusting the movable support in one direction and the actuating device in a different direction to

determine the impression device to be operated.

21. In a machine of the class described, the combination with a plurality of impression devices arranged in rows, of an adjustable actuating device common to all of the impression devices, movable means in which the impression devices are slidably mounted, and means for simultaneously adjusting the actuating device and said movable means whereby to select the row and the platen in the row to be actuated.

22. In a machine of the class described, the combination with a movable group of impression devices, of an adjustable actuating device common thereto, means for differentially adjusting the actuating device to establish operative relationship between same and any impression device of the group, means for positioning the actuator to receive said impression device and then operating the actuating device and impression device as a unit, and means for moving the impression devices whereby to engage the impression device in operative relationship to the actuating device with the actuating device.

23. In a machine of the class described, the combination with a plurality of vertically movable impression devices, the set of impression devices being movable in two directions in a horizontal plane, a differentially adjustable and vertically movable actuating device common to the impression devices, means for simultaneously imparting horizontal bodily movement in one direction to the impression devices and effecting differential adjustment of the actuating device whereby to establish operative relationship between the actuating means and the desired impression device, means for imparting vertical movements to the actuating device, and means for imparting bodily movement in a second horizontal direction to the set of impression devices to engage the actuating device and the impression device in operative relation therewith whereby the vertical movement of the actuating device will operate the engaged impression device.

24. In a machine of the class described, the combination with a series of platens, of an actuating device common thereto, means for differentially adjusting said actuating device to establish operative relationship between the device and any desired platen, and means for operatively connecting the actuating device with the platen in operative relationship thereto.

25. In a machine of the class described, the combination with a plurality of series of platens, of an actuating device common to all of the platens, manipulative devices, means controlled by the manipulative devices for moving any series of platens into

operative relationship with the actuator and adjusting the actuator to establish operative relationship between the actuator and the desired platen of the series.

26. In a machine of the class described, the combination with a series of platens, of an actuating device common thereto, and means for adjusting said actuating device to establish operative relation between the device and any desired platen, said means adjusting the actuator directly from one position to another without a return movement to a normal starting point.

27. In a machine of the class described, the combination with a series of platens, of a platen actuating device common thereto, manipulative devices operable to select the platen to be actuated, and operating mechanism controlled by said manipulative devices for first adjusting the actuating device directly from one position to another to establish operative relationship between said device and the selected platen and then actuating the platen.

28. In a machine of the class described, the combination with a main operating mechanism, of a plurality of platens, a platen operating device common to said platens and constructed to positively raise and lower any one of the platens, means for differentially adjusting the operating device to establish operative relationship between said device and any desired platen, and means for operatively connecting and disconnecting said platen and the platen operating device.

29. In a machine of the class described, the combination with a main operating mechanism, of a plurality of platens, a platen operating device common to said platens, means for differentially moving the operating device to establish operative relationship between said device and any desired platen, and means for operatively connecting and disconnecting said platen and the platen operating device.

30. In a machine of the class described, the combination with a series of platen carrying elements, of an actuating device common thereto, means for differentially moving said actuating device to select the element to be operated, means for imparting movements of invariable extent to said actuating device, and means for engaging and disengaging the selected element and the actuator.

31. In a machine of the class described, the combination with a series of platen carrying elements, of an actuating device common thereto constructed to positively raise and lower any one of said elements, means for differentially adjusting the actuating device directly and in either direction to determine the element to be operated, means for imparting movements of invariable extent to the actuator in any of its positions

of adjustment, and means for engaging and disengaging the element to be operated and the actuator.

32. In a machine of the class described, the combination with a plurality of type carriers, of a plurality of platens, a common actuating device for the platens, a differentially adjustable carriage in which the type carriers and the actuating device are movably mounted, and means for differentially adjusting the carriage to position the type carriers and actuating devices in operative relationship with any desired platen.

33. In a machine of the class described, the combination with a plurality of type carriers, of a plurality of platens, a platen actuating device common to the platens, a differentially movable carriage in which the type carriers and the platen actuating device are movably mounted, and means for differentially moving the carriage to position the type carriers and platen actuating device in operative relationship with any desired platen, said means moving the carriage directly from one position to another without a return movement to a normal starting point.

34. In a machine of the class described, the combination with a plurality of type carriers, of a plurality of series of platens, a movable means supporting all of the series of platens, a platen actuating device common to the platens, a differentially movable carriage in which the type carriers and the platen actuating device are movably mounted, means for moving the platen supporting means to bring any desired series in operative relationship with the actuators and type carriers, and means for differentially moving the aforesaid carriage directly from one position to another to move the type carriers and platen actuating device into operative relation with any desired platen of the series.

35. In a machine of the class described, the combination with a plurality of type carriers, of a plurality of platens, a pair of actuator plates common to all of the platens, a differentially movable carriage in which the type carriers and the actuator plates are movably mounted, manipulative devices operable to select the platen to be operated, means controlled by said manipulative devices for differentially moving the carriage to position the type carriers and actuating plates in operative relationship with the selected platen, said means moving the carriage directly from one position to another without a return movement to a normal starting point, and means for differentially adjusting the type carriers during movement of the carriage to set up the item to be printed by means of the selected platen.

36. In a machine of the class described, the combination with a plurality of type car-

- riers, of a plurality of platens, a movable carriage in which the type carriers are adjustably mounted, means for moving said carriage to position the type carriers in operative relationship with any desired platen, and means for adjusting the type carriers to set up the items to be printed by means of said platen.
37. In a machine of the class described, the combination with a plurality of type carriers, of a plurality of platens, a movable carriage in which the type carriers are adjustably mounted, means for moving said carriage directly from one position to another to establish operative relationship between the type carriers and any desired platen, and means for adjusting the type carriers to set up thereon the item to be printed by means of said platen.
38. In a machine of the class described, the combination with a set of type carriers, of a carriage in which the type carriers are movably mounted, a plurality of platens, means for moving the carriage to position the type carriers in operative relationship with any desired platen, and means for setting up on the type carriers during movement of the carriage the item to be printed by the actuation of said platen.
39. In a machine of the class described, the combination with a set of type carriers, of a carriage in which the type carriers are adjustably mounted, a plurality of platens, means for moving the carriage directly and in either direction from one position to another whereby to establish operative relationship between the type carriers and any desired platen, and means for setting up on the type carriers during movement of the carriage the item to be printed by actuation of said platen.
40. In a machine of the class described, the combination with a plurality of groups of impression devices, of manipulative devices operable to select the group and impression devices of the group to be operated, operating mechanism controlled by said manipulative devices for operating the selected impression device, record strip feeding devices carried by each impression device, and means whereby said feeding devices are driven when the impression devices are operated.
41. In a machine of the class described, the combination with a series of holders for independent record strips, of a set of type carriers having two sets of type, each set to print against half of the record strips in the series and the sets so spaced apart that the printing line of one set only is effective at a time, means for operating the type carriers to present either printing line opposite the record strip to be printed upon by that particular set of type, and means for taking an impression on said record strip.
42. In a machine of the class described, the combination with a series of independent platens, of a set of type carriers having two sets of type, each set to print against half of the platens in the series and the sets so spaced apart that the printing line of one set only is effective at a time, means for operating the type carriers to present either printing line opposite the desired one of the platens cooperating with that particular set of type, and means for operating the platen to take an impression.
43. In a machine of the class described, the combination with a series of platens, of a set of type carriers having two sets of type, each set to print against half of the platens in the series, means for operating the type carriers to set up an item opposite any desired platen in either half or the series, and means for operating the platen to take the impression.
44. In a machine of the class described, the combination with a series of accounting devices, of actuating devices adjustable to different positions and comprising two pairs of operating projections, each pair to operate the accounting devices in half of the series and the pairs so spaced apart that only one pair is effective in any position of the actuating devices, and means for adjusting the actuating devices to establish operative relationship between the accounting device to be actuated and the operating projections therefor.
45. In a machine of the class described, the combination with a series of accounting devices, of actuating devices adjustable to different positions and comprising two pairs of lugs, each pair to operate the accounting devices in half of the series and the pairs so spaced apart that only one pair is effective in any position of the actuating devices, and means for adjusting the actuating devices directly from one position to another to establish operative relationship between the accounting device to be actuated and the operating lugs therefor.
46. In a machine of the class described, the combination with a row of platens, of actuating devices adjustable to different positions and comprising two pairs of lugs, each pair to operate platens in half of the row and the pairs so spaced apart that only one pair is effective in any position of the actuating devices, and means for adjusting the actuating devices directly from one position to another to establish operative relationship between the platen to be actuated and the operating lugs therefor.
47. In a machine of the class described, the combination with a plurality of record strip devices, of a plurality of manipulative devices operable singly or in various combinations according to the record strip device which is to receive the record, and in-

tervening mechanism controlled by said manipulative devices for effecting the operation of the selected record strip device.

48. In a machine of the class described, the combination with a plurality of parallel rows of record strip devices, of a key bank for each row of said devices, and intervening mechanism controlled jointly by the key banks for effecting operation of any one of the record strip devices.

49. In a machine of the class described, the combination with a keyboard comprising a plurality of clerks' number key banks and a plurality of amount key banks, of a plurality of rows of record strip devices arranged in parallel rows, and mechanism controlled by the number and amount keys whereby any amount set up on the amount keys may be printed on any desired record strip.

50. In a machine of the class described, the combination with a set of type carriers, of a row of independently operable platens, means for independently moving the type carriers directly from one position to another for setting up items, and moving the set of type carriers directly from one position to another to present the item opposite any desired platen in the row, and means for operating the platen to print said items.

51. In a machine of the class described, the combination with a series of platens, of a type carrier, a series of keys and devices controlled thereby for imparting item setting movement to the type carrier, a series of clerks' keys, and means controlled by the clerks' keys for positioning the type carrier to cooperate with any desired platen to print the item.

52. In a machine of the class described, the combination with a set of type carriers, of a carriage in which the type carriers are adjustably mounted, a plurality of holders for independent record strips, means for adjusting the type carriers in their carriage to set up items at a printing line, and means for moving the carriage to position the printing line opposite any desired record strip.

53. In a machine of the class described, the combination with a set of type carriers, of a carriage in which the type carriers are adjustably mounted, a plurality of independent record strips, means for moving the type carriers directly and in either direction from one position to another to set up items at a printing line, and means for moving the carriage directly and in either direction from one position to another to present the printing line of type opposite any desired record strip.

54. In a machine of the class described, the combination with a plurality of groups of accounting devices, of a plurality of independently movable elements, a plurality of key banks each controlling movement of one of said elements, and accounting device selecting mechanism operatively connected to and controlled by the movable elements to select for operation any accounting device in any group.

In testimony whereof I affix my signature in the presence of two witnesses.

FRED M. CARROLL.

Witnesses:

F. E. HAMILTON,  
A. A. MINTERS.